



STAATSKOERANT
VAN DIE REPUBLIEK VAN SUID-AFRIKA
REPUBLIC OF SOUTH AFRICA
GOVERNMENT GAZETTE

PRYS 40c PRICE
Plus AVB/GST

As 'n Nuusblad by die Poskantoor Geregistreer

BUITELANDS 50c ABROAD
POSVRY · POST FREE

Registered at the Post Office as a Newspaper

Vol. 228

PRETORIA, 8 JUNIE 1984
JUNE

No. 9247

PROKLAMASIES

van die

Staatspresident van die Republiek van Suid-Afrika

No. 84, 1984

**VERKLARING VAN 'N NASIONALE PAD.—
PROVINSIE DIE KAAP DIE GOEIE HOOP**

Kragtens artikel 4 (1) (a) van die Wet op Nasionale Paaie, 1971 (Wet 54 van 1971), soos gewysig, verklaar ek hierby dat die roete wat in die Bylae hiervan beskryf word, 'n nasionale pad is.

Gegee onder my Hand en die Seël van die Republiek van Suid-Afrika te Pretoria, op hede die Agt-en-twintigste dag van Maart Eenduisend Negehonderd Vier-en-tagtig.

M. VILJOEN, Staatspresident.

Op las van die Staatspresident-in-rade:

H. S. J. SCHOEMAN.

BYLAE

PROVINSIE DIE KAAP DIE GOEIE HOOP

Beskrywing van roete

'n Roete, soos opgemeet en getoon op bygaande Plan P337/83, wat begin op Plaas 587; en daarvandaan loop oor genoemde plaas en oor Restante van Gedeeltes 9 en 11, Gedeelte 19, Restante van Gedeeltes 2, 3 en 1 en Gedeeltes 24, 13, 14 en 15, almal van Elandsjagt 585; Staatsgrond 584; Plaas 631; Plaas 648; Restant van Gedeelte 2 van Gevonden 522 en Gedeelte 2 van Toitskloof 517, waar dit eindig ('n totale afstand van ongeveer 17,2 km).

(Nasionale Roete: Elandsrivier—Groote Eiland, distrikte die Paarl en Worcester.)

PROCLAMATIONS

by the

State President of the Republic of South Africa

No. 84, 1984

**DECLARATION OF A NATIONAL ROAD.—
PROVINCE OF THE CAPE OF GOOD HOPE**

In terms of section 4 (1) (a) of the National Roads Act, 1971 (Act 54 of 1971), as amended, I hereby declare that the route described in the Schedule hereto shall be a national road.

Given under my Hand and the Seal of the Republic of South Africa at Pretoria this Twenty-eighth day of March, One thousand Nine hundred and Eighty-four.

M. VILJOEN, State President.

By Order of the State President-in-Council:

H. S. J. SCHOEMAN.

SCHEDULE

PROVINCE OF THE CAPE OF GOOD HOPE

Description of route

A route, as surveyed and indicated on the attached Plan P337/83, commencing on Farm 587; and thence proceeding over the said farm and over Remainders of Portions 9 and 11, Portion 19, Remainders of Portions 2, 3 and 1 and Portions 24, 13, 14 and 15, all of Elandsjagt 585; Staatsgrond 584; Farm 631, Farm 648; Remainder of Portion 2 of Gevonden 522 and Portion 2 of Toitskloof 517, where it terminates (a total distance of about 17,2 km).

(National Route: Elands River—Groote Eiland, Districts of the Paarl and Worcester.)

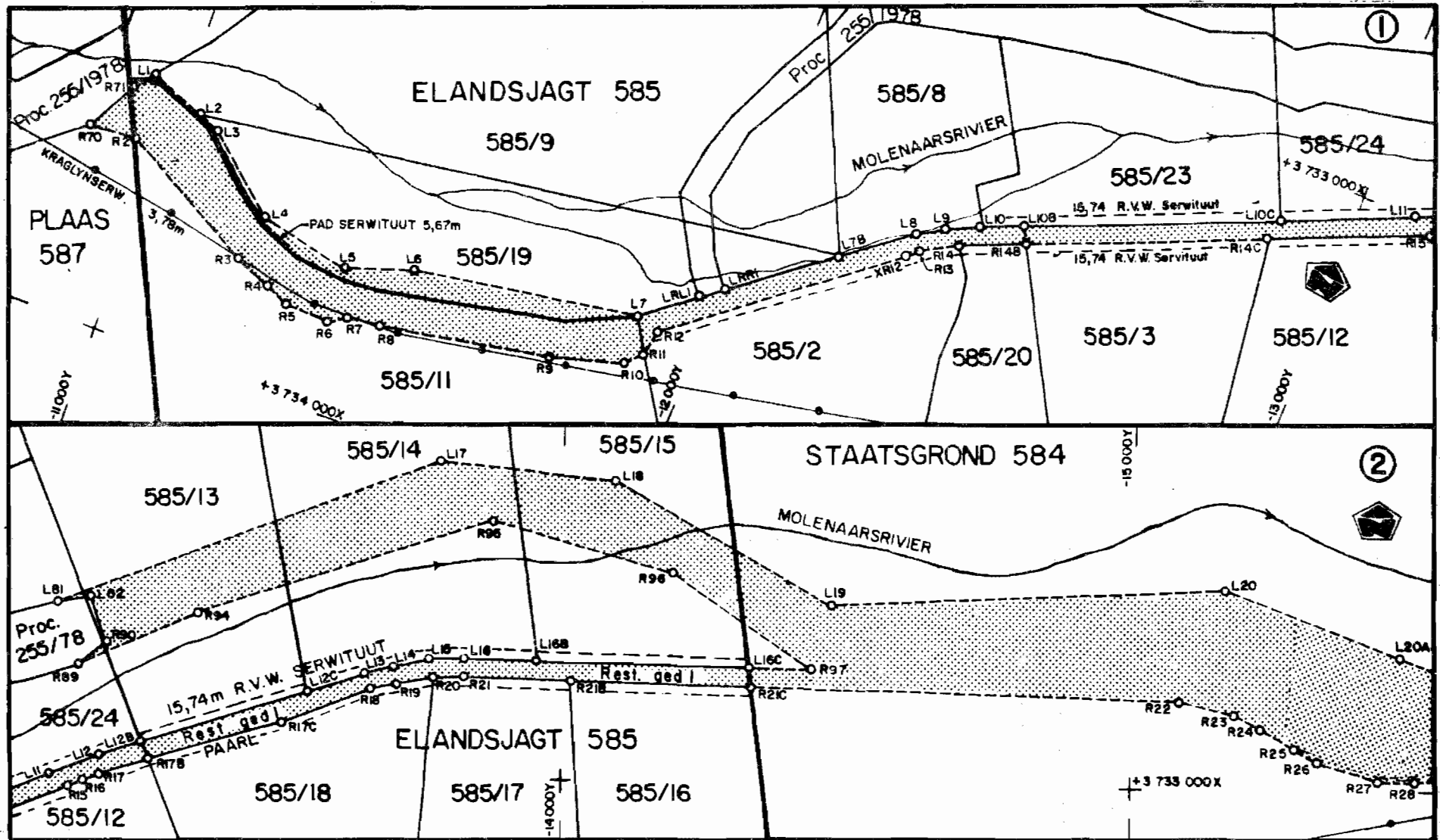

Nasionale Vervoerkommissie National Transport Commission	Die figuur getoon The figure shown		stel die padreserwe voor van 'n gedeelte represents the road reserve of a portion van Nasionale Roete Seksie of National Route Section	Vel Sheet	van of 7
				P 337/83	

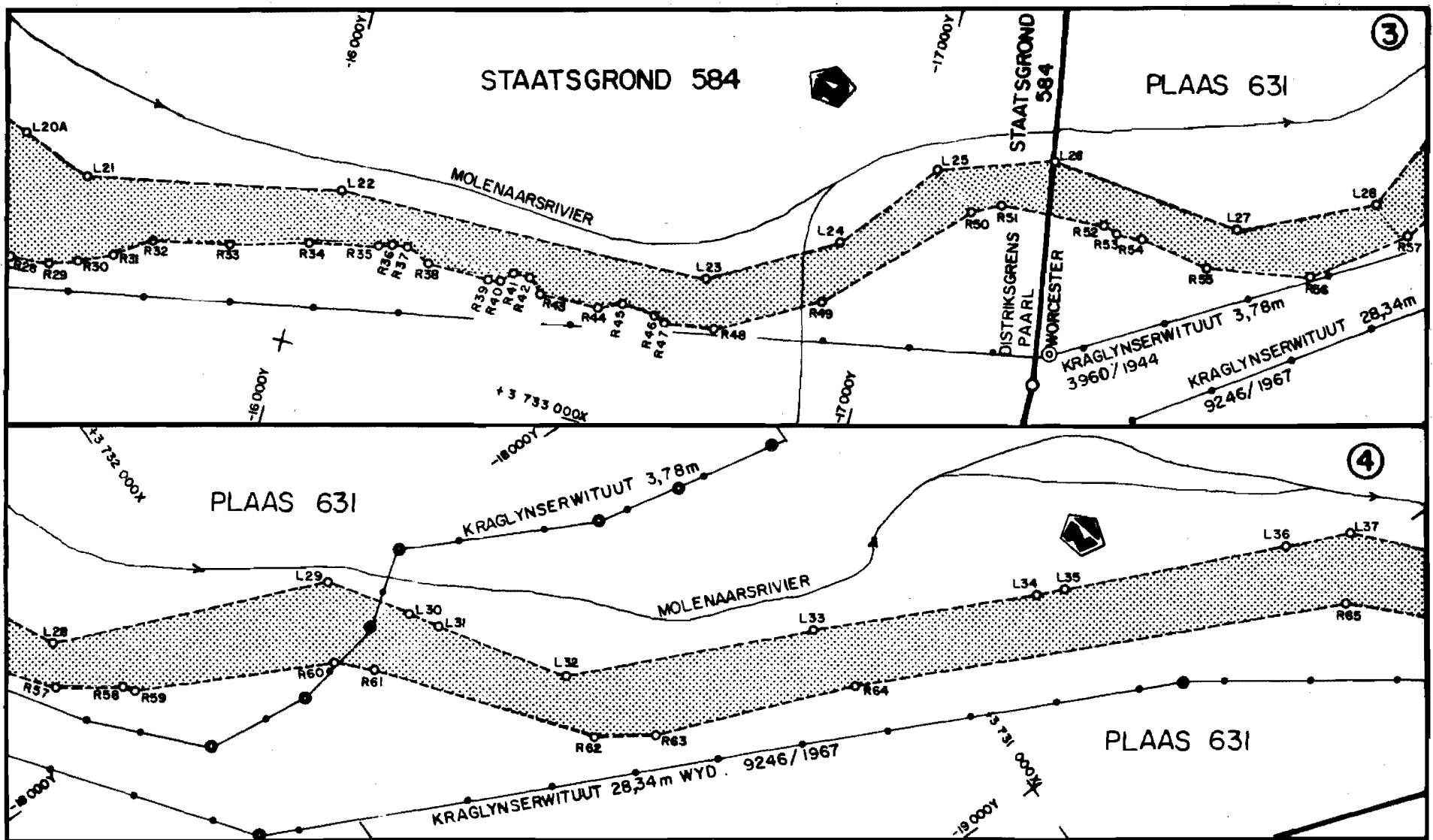

GOVERNMENT GAZETTE, 8 JUNE 1984

No. 9247 3

<p>Nasionale Vervoerkommissie National Transport Commission</p>	<p>Die figuur getoon The figure shown</p> <div style="border: 1px solid black; width: 50px; height: 30px; margin: 5px auto;"></div>	<p>stel die padreserwe voor van 'n gedeelte represents the road reserve of a portion van Nasionale Roete 1 Seksie 1+2 of National Route Section</p>	<p>Vel van Sheet 2 of 7 P 337/83</p>
---	---	---	---

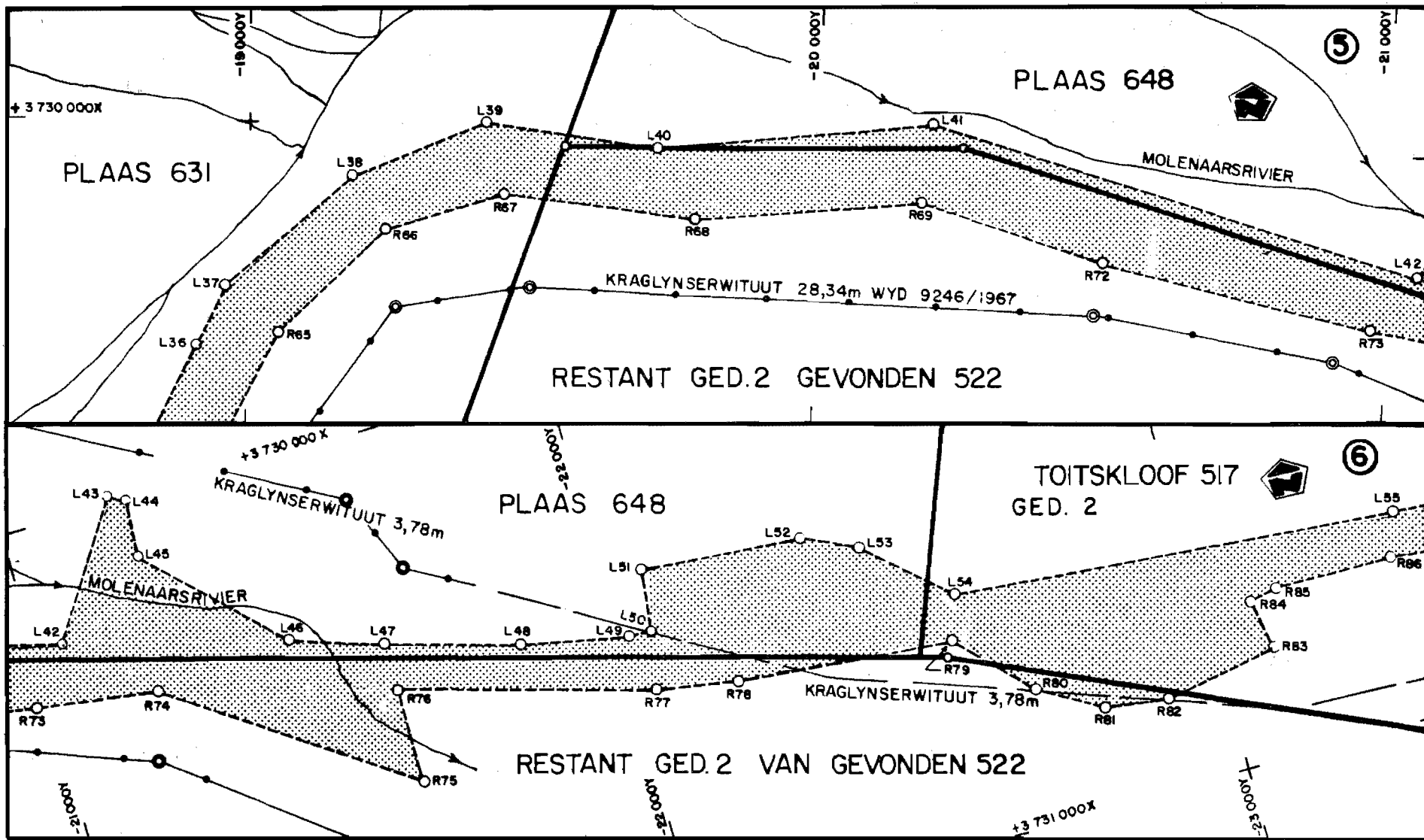

<p>Nasionale Vervoerkommissie National Transport Commission</p>	<p>Die figuur getoon The figure shown</p> <div style="border: 1px solid black; width: 40px; height: 40px; margin: 5px auto;"></div>	<p>stel die padreserwe voor van 'n gedeelte represents the road reserve of a portion van Nasionale Roete 1 Seksie 2 of National Route Section</p>	<p>Vol van Sheet 3 of 7 P 337/83</p>
---	---	--	--

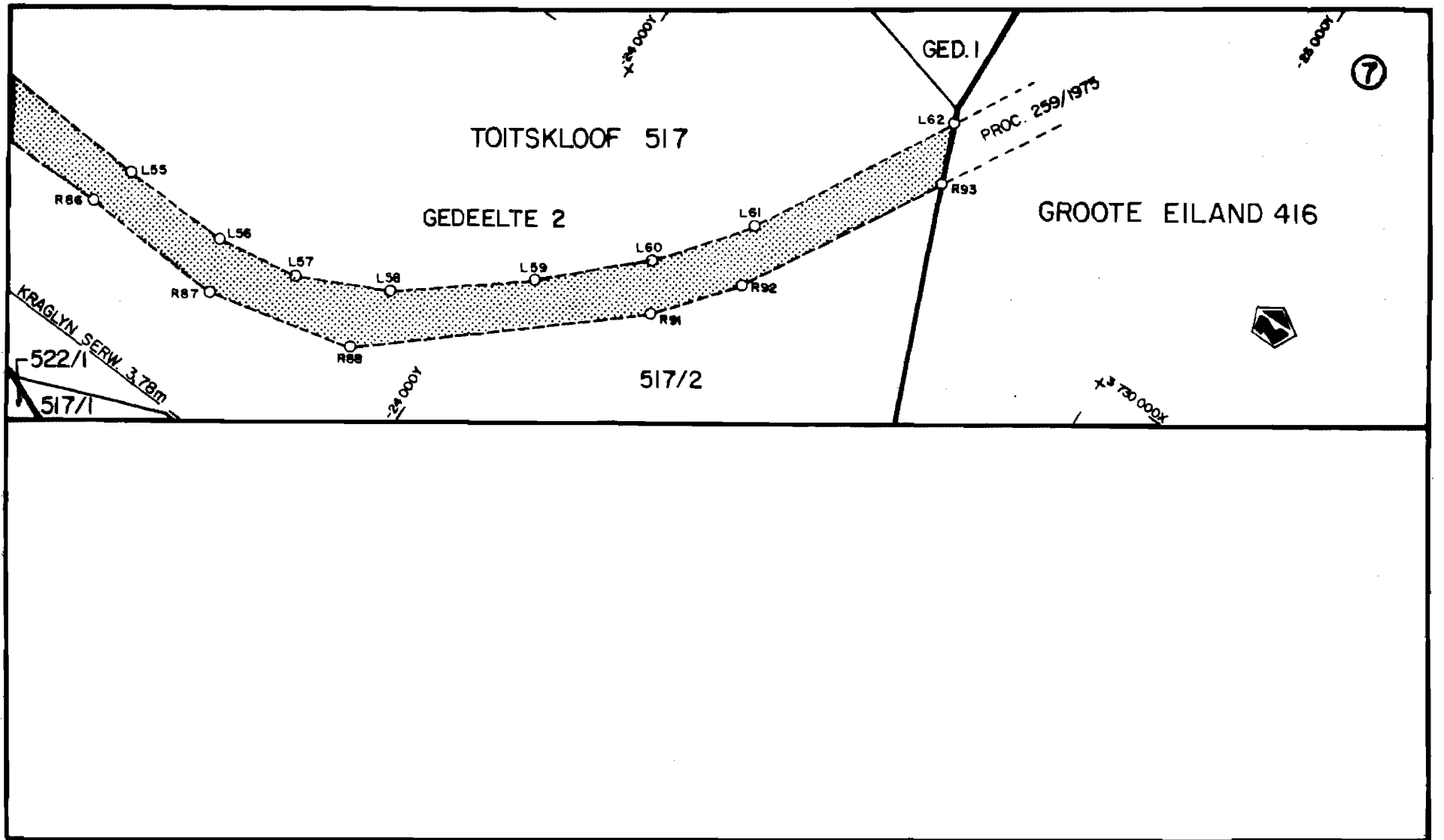

GOVERNMENT GAZETTE, 8 JUNE 1984

No. 9247 5

<p>Nasionale Vervoërkommissie National Transport Commission</p>	<p>Die figuur getoon The figure shown</p>		<p>stel die padreserwe voor van 'n gedeelte represents the road reserve of a portion van Nasionale Roete 1 Sektie of National Route Section 2</p>	<p>Vol 4 van 7 Sheet of P 337/83</p>
---	---	--	---	--

PADRESERWE KOÖRDINATE / ROAD RESERVE CO-ORDINATES

LINKERKANT / LEFT HAND SIDE

REGTERKANT / RIGHT HAND SIDE

Y X
 Konstant / Constant

Lo 19° Y X
 Konstant / Constant

± 0,00 + 3 700 000,00

± 0,00 + 3 700 000,00

L1 -	10 940,40	33 545,78
L2 -	11 039,50	33 582,50
L3 -	11 076,50	33 599,50
L4 -	11 208,00	33 711,00
L5 -	11 370,50	33 745,00
L6 -	11 485,00	33 704,00
L7 -	11 885,15	33 640,41
LRL1-	11 975,51	33 571,89
LRR1-	12 011,43	33 544,79
L7B -	12 175,30	33 421,43
L8 -	12 289,11	33 335,53
L9 -	12 334,10	33 310,50
L10 -	12 389,88	33 286,37
L10B-	12 460,03	33 258,17
L10C-	12 875,31	33 090,81
L11 -	13 095,50	32 999,00
L12 -	13 186,62	32 965,35
L12B-	13 258,16	32 942,21
L12C-	13 549,59	32 850,43
L13 -	13 650,50	32 816,00
L14 -	13 699,74	32 803,14
L15 -	13 762,46	32 792,78
L16 -	13 824,36	32 788,82
L16B-	13 951,94	32 791,59
L16C-	14 327,35	32 799,77
L17 -	13 780,11	32 443,13
L18 -	14 088,13	32 472,41
L19 -	14 471,92	32 687,10
L20 -	15 160,04	32 651,16
L20A-	15 469,62	32 765,44
L21 -	15 594,30	32 811,46
L22 -	16 032,00	32 719,01
L23 -	16 693,00	32 698,90
L24 -	16 904,73	32 573,56
L25 -	17 036,74	32 405,17
L26 -	17 230,20	32 338,41
L27 -	17 570,26	32 367,99
L28 -	17 794,57	32 259,69
L29 -	17 989,15	31 801,63
L30 -	18 115,57	31 718,08
L31 -	18 162,17	31 687,28
L32 -	18 363,83	31 554,00
L33 -	18 550,00	31 154,50
L34 -	18 729,00	30 798,00

R70 -	10 866,00	33 667,20
R71 -	10 912,51	33 579,10
R2 -	10 946,00	33 662,50
R3 -	11 190,00	33 795,50
R4 -	11 254,50	33 820,50
R5 -	11 297,00	33 840,00
R6 -	11 375,50	33 843,50
R7 -	11 406,50	33 826,00
R8 -	11 463,00	33 818,50
R9 -	11 762,00	33 763,00
R10 -	11 892,00	33 728,00
R11 -	11 917,50	33 702,00
R12 -	11 928,50	33 657,20
XRI2-	12 283,35	33 379,17
R13 -	12 306,50	33 362,00
R14 -	12 366,00	33 328,50
R14B-	12 474,99	33 285,36
R14C-	12 865,24	33 126,98
R15 -	13 130,05	33 019,75
R16 -	13 157,28	33 009,22
R17 -	13 186,14	32 998,82
R17B-	13 270,19	32 971,43
R17C-	13 506,00	32 904,50
R18 -	13 660,50	32 845,00
R19 -	13 707,05	32 833,84
R20 -	13 766,02	32 824,11
R21 -	13 824,99	32 820,33
R21B-	14 013,88	32 824,43
R21C-	14 331,38	32 831,35
R22 -	15 079,50	32 848,00
R23 -	15 177,00	32 870,00
R24 -	15 226,00	32 893,50
R25 -	15 280,50	32 927,50
R26 -	15 324,00	32 949,50
R27 -	15 432,00	32 982,50
R28 -	15 495,50	32 984,50
R29 -	15 569,00	32 975,00
R30 -	15 616,00	32 959,50
R31 -	15 675,00	32 933,50
R32 -	15 735,10	32 891,95
R33 -	15 866,43	32 862,59
R34 -	16 001,50	32 822,30
R35 -	16 121,39	32 798,99
R36 -	16 140,54	32 785,82
R37 -	16 171,19	32 782,11
R38 -	16 213,26	32 802,65

Vel 5 van 7 P 337/83
 Sheef of

PADRESERWE KOÖRDINATE / ROAD RESERVE CO-ORDINATES**LINKERKANT/LEFT HAND SIDE****REGTERKANT/RIGHT HAND SIDE**

Y **X**
Konstant / Constant

Lo 19° Y **X**
Konstant / Constant

± 0,00 + 3 700 000,00

± 0,00 + 3 700 000,00

L35 - 18 747,00 30 752,50
L36 - 18 913,00 30 391,00
L37 - 18 960,08 30 286,02
L38 - 19 178,05 30 088,39
L39 - 19 414,44 29 987,79
L40 - 19 719,62 30 024,08
L41 - 20 198,87 29 965,61
L42 - 21 052,53 30 211,81
L43 - 21 200,00 29 984,58
L44 - 21 229,05 30 000,00
L45 - 21 222,00 30 102,00
L46 - 21 438,39 30 317,34
L47 - 21 600,00 30 370,99
L48 - 21 831,28 30 437,36
L49 - 22 021,14 30 478,36
L50 - 22 062,97 30 479,24
L51 - 22 074,14 30 371,41
L52 - 22 356,50 30 395,00
L53 - 22 452,50 30 437,00
L54 - 22 590,92 30 563,18
L55 - 23 367,78 30 633,09
L56 - 23 563,57 30 645,37
L57 - 23 711,14 30 627,81
L58 - 23 862,92 30 557,75
L59 - 24 063,80 30 400,92
L60 - 24 221,16 30 255,71
L61 - 24 339,74 30 107,02
L62 - 24 529,51 29 761,58

R39 - 16 313,47 32 801,02
R40 - 16 343,32 32 794,29
R41 - 16 362,97 32 779,81
R42 - 16 392,96 32 779,09
R43 - 16 418,45 32 798,97
R44 - 16 523,44 32 796,93
R45 - 16 563,08 32 781,96
R46 - 16 623,16 32 784,51
R47 - 16 643,36 32 792,52
R48 - 16 729,90 32 780,63
R49 - 16 901,15 32 682,44
R50 - 17 112,80 32 461,11
R51 - 17 161,27 32 435,28
R52 - 17 343,69 32 423,27
R53 - 17 368,04 32 430,95
R54 - 17 413,99 32 429,17
R55 - 17 537,41 32 447,95
R56 - 17 716,32 32 412,62
R57 - 17 861,57 32 300,99
R58 - 17 927,61 32 205,08
R59 - 17 942,56 32 190,71
R60 - 18 109,16 31 877,52
R61 - 18 159,21 31 827,11
R62 - 18 479,27 31 577,27
R63 - 18 539,84 31 486,77
R64 - 18 673,16 31 149,83
R65 - 19 056,42 30 366,20
R66 - 19 241,90 30 179,89
R67 - 19 449,01 30 113,39
R68 - 19 788,47 30 147,75
R69 - 20 183,58 30 106,40
R72 - 20 503,17 30 203,94
R73 - 20 974,97 30 307,66
R74 - 21 191,35 30 339,27
R75 - 21 600,00 30 623,00
R76 - 21 600,00 30 454,22
R77 - 22 042,02 30 581,07
R78 - 22 183,34 30 606,83
R79 - 22 563,83 30 641,07
R80 - 22 680,80 30 763,20
R81 - 22 788,80 30 826,80
R82 - 22 900,50 30 843,00
R83 - 23 102,60 30 805,55
R84 - 23 083,83 30 716,50
R85 - 23 133,29 30 707,32

L81 - 13 108,88 32 697,73
L82 - 13 168,68 32 686,61

Vel Sheet 6 van of 7 P 337/83

PADRESERWE KOÖRDINATE / ROAD RESERVE CO-ORDINATES

LINKERKANT / LEFT HAND SIDE

REGTERKANT / RIGHT HAND SIDE

Y X
Konstant / Constant

Lo 19° Y X
Konstant / Constant

± 0,00 + 3 700 000,00

± 0,00 + 3 700 000,00

R86 - 23 340,69	30 710,97
R87 - 23 600,00	30 734,30
R88 - 23 860,99	30 677,52
R91 - 24 272,58	30 333,18
R92 - 24 379,30	30 203,91
R93 - 24 572,48	29 862,62
R94 - 13 356,62	32 714,92
R95 - 13 874,46	32 547,69
R96 - 14 191,46	32 632,92
R97 - 14 438,00	32 802,00
R89 - 13 148,53	32 806,74
R90 - 13 198,08	32 767,43

No. 89, 1984

UMVOTI-BESPROEINGSDISTRIK, DISTRIK
UMVOTI, NATAL.—INSTELLING

Nademaal eienaars van oewergrond aan die Umvoti- en die Mvozanarivier ingevolge artikel 71 (1) van die Waterwet, 1956 (Wet 54 van 1956), aan die Minister van Omgewingsake en Visserye 'n versoekskrif voorgelê het waarin vermeld word dat dit na die mening van die petisionarisse wenslik is dat die uitneem en gebruik van die water van die Umvoti- en die Mvozanarivier in die betrokke gebied spesiaal beheer behoort te word;

En nademaal al die bepalings van genoemde Wet met betrekking tot sodanige versoekskrif nagekom is;

En nademaal die Staatspresident kragtens artikel 74 (1) van genoemde Wet 'n gebied op aanbeveling van die Minister van Omgewingsake en Visserye tot 'n besproeiingsdistrik kan verklaar en genoemde Minister sodanige aanbeveling ingevolge artikel 72 (3) (a) van genoemde Wet verstrek het;

So is dit dat ek kragtens die bevoegdheid my verleen by artikel 74 (1) van genoemde Wet hierby verklaar dat die gebied beskryf in die Bylae hiervan 'n besproeiingsdistrik uitmaak wat bekend staan as die Umvoti-besproeiingsdistrik;

En voorts verklaar ek hierby kragtens die bevoegdheid my verleen by artikel 79 (1) van genoemde Wet dat daar vir genoemde besproeiingsdistrik 'n besproeiingsraad is wat as die Umvoti-besproeiingsraad bekend staan.

Gegee onder my Hand en die Seël van die Republiek van Suid-Afrika te Pretoria, op hede die Veertiende dag van Mei Eenduuisend Negehonderd Vier-en-tagtig.

M. VILJOEN, Staatspresident.

Op las van die Staatspresident-in-rade:

S. A. S. HAYWARD.

BYLAE

BESKRYWING VAN DIE EIENDOMME WAT DIE
UMVOTI-BESPROEINGSDISTRIK, DISTRIK UMVOTI,
NATAL, UITMAAK

Overvloed 1338.
Klipfontein 3764.
Rust 1112.
Berhill 12809.
Groote Riet Vallei 1131.
Smalhoek 1083.
Patience 15256.
Murrayfield 14852.
Umvozana 14853.
Summerford 9688.
Lot 21 van 1827.
Lot 22 van 1921.
Lot 23 van 1839.
Welgevonden 1132.
Endeavour 15429.
Speculation 1940.
Mispa 1306.
Burleigh 1863.
Canema 1881.
Baviaans Krans 1981.
Mistley 2034.
Makayane 13733.
Sophia Dale 1360.
Matchwood Vley 12668.
Umvoti Vley 1886.
Kuzan 14412.
Hartbeestfontein 1362.
Schoon Zigt 1095.
Middle Drift 1098.
Falkenstein 14530.
Falkenstein 15441.

No. 89, 1984

UMVOTI IRRIGATION DISTRICT, DISTRICT OF
UMVOTI, NATAL.—ESTABLISHMENT

Whereas owners of land riparian to the Umvoti and the Mvozana Rivers have, in terms of section 71 (1) of the Water Act, 1956 (Act 54 of 1956), submitted to the Minister of Environment Affairs and Fisheries a petition stating that, in the opinion of the petitioners, it is desirable that the abstraction and use of the water of the Umvoti and the Mvozana Rivers in the area concerned be specially controlled;

And whereas all the provisions of the said Act relating to such petition have been complied with;

And whereas the State President may, in terms of section 74 (1) of the said Act, upon the recommendation of the Minister of Environment Affairs and Fisheries, declare an area to be an irrigation district and the said Minister has furnished such recommendation in terms of section 72 (3) (a) of the said Act;

Now, therefore, under and by virtue of the powers vested in me by section 74 (1) of the said Act, I hereby declare that the area described in the Schedule hereto shall constitute an irrigation district, to be known as the Umvoti Irrigation District;

And, under and by virtue of the powers vested in me by section 79 (1) of the said Act, I hereby further declare that there shall be an irrigation board for the said irrigation district, to be known as the Umvoti Irrigation Board.

Given under my Hand and the Seal of the Republic of South Africa at Pretoria this Fourteenth day of May, One thousand Nine hundred and Eighty-four.

M. VILJOEN, State President.

By Order of the State President-in-Council:

S. A. S. HAYWARD.

SCHEDULE

DESCRIPTION OF THE PROPERTIES CONSTITUTING
THE UMVOTI IRRIGATION DISTRICT, DISTRICT OF
UMVOTI, NATAL

Overvloed 1338.
Klipfontein 3764.
Rust 1112.
Berhill 12809.
Groote Riet Vallei 1131.
Smalhoek 1083.
Patience 15256.
Murrayfield 14852.
Umvozana 14853.
Summerford 9688.
Lot 21 of 1827.
Lot 22 of 1921.
Lot 23 of 1839.
Welgevonden 1132.
Endeavour 15429.
Speculation 1940.
Mispa 1306.
Burleigh 1863.
Canema 1881.
Baviaans Krans 1981.
Mistley 2034.
Makayane 13733.
Sophia Dale 1360.
Matchwood Vley 12668.
Umvoti Vley 1886.
Kuzan 14412.
Hartbeestfontein 1362.
Schoon Zigt 1095.
Middle Drift 1098.
Falkenstein 14530.
Falkenstein 15441.

Brocken 13431.
Heidelberg 15442.
Misgunst 1191.

Brocken 13431.
Heidelberg 15442.
Misgunst 1191.

'n Plan wat die grense van die Besproeiingsdistrik aandui, verskyn hieronder.

A plan showing the borders of the Irrigation District appears below.

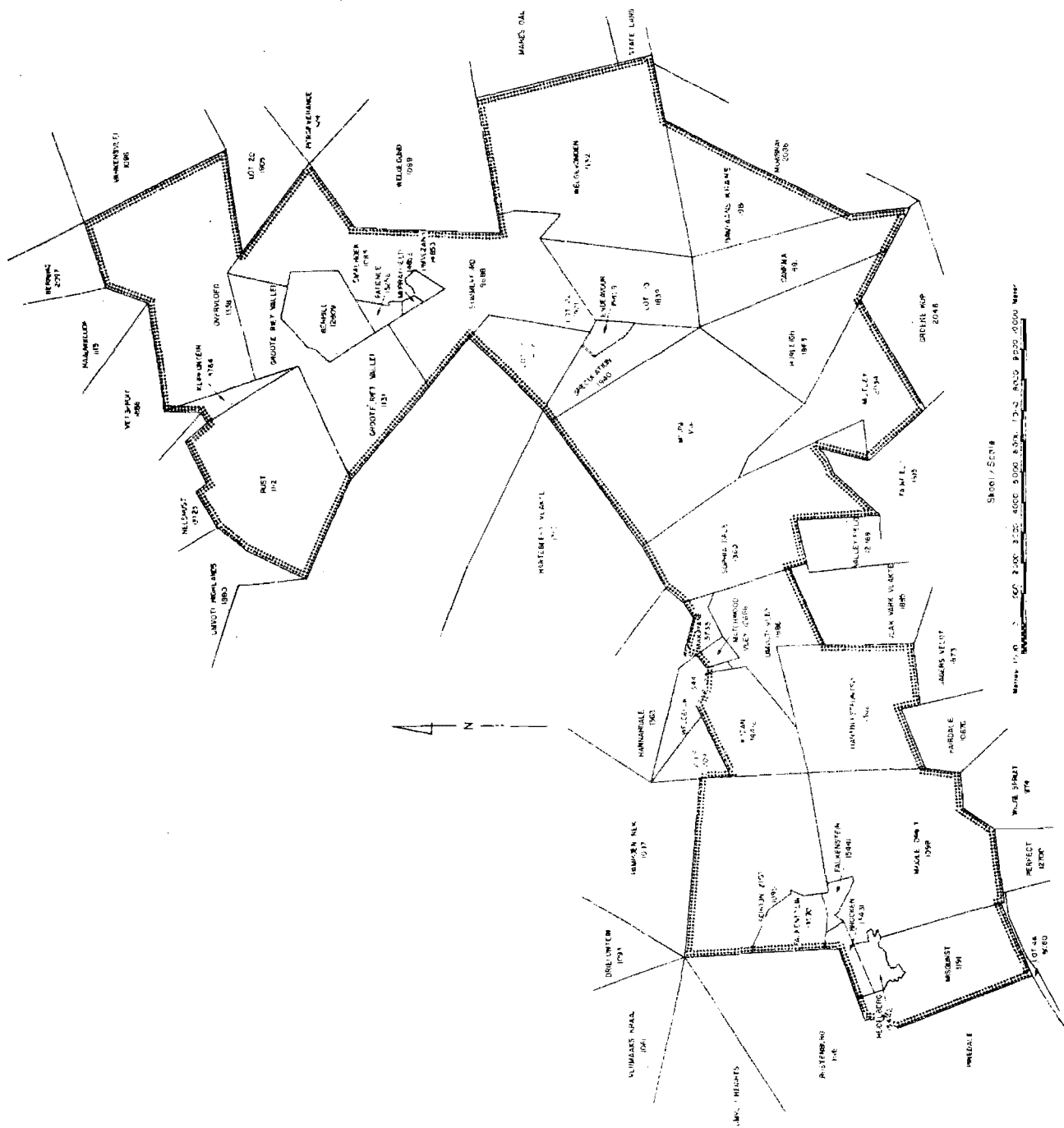

No. 90, 1984

MNYAMVUBU-BESPROEIINGSDISTRIK, DISTRIK UMVOTI, NATAL.—INSTELLING

Nademaal eienaars van oewergrond aan die Mnyamvuburivier ingevolge artikel 71 (1) van die Waterwet, 1956 (Wet 54 van 1956), aan die Minister van Omgewingsake en Visserye 'n versoekskrif voorgelê het waarin vermeld word dat dit na die mening van die petisionarisse wenslik is dat die distribusie en gebruik van water van die Mnyamvuburivier spesiaal beheer behoort te word;

En nademaal al die bepalings van genoemde Wet met betrekking tot sodanige versoekskrif nagekom is;

En nademaal die Staatspresident kragtens artikel 74 (1) van genoemde Wet 'n gebied op aanbeveling van die Minister van Omgewingsake en Visserye tot 'n besproeiingsdistrik kan verklaar en genoemde Minister sodanige aanbeveling ingevolge artikel 72 (3) (a) van genoemde Wet verstrekket het;

So is dit dat ek, kragtens die bevoegdheid my verleen by artikel 74 (1) van genoemde Wet, hierby verklaar dat die gebied beskryf in die Bylae hiervan 'n besproeiingsdistrik uitmaak wat bekend staan as die Mnyamvubu-besproeiingsdistrik;

En voorts verklaar ek hierby, kragtens die bevoegdheid my verleen by artikel 79 (1) van genoemde Wet, dat daar vir genoemde besproeiingsdistrik 'n besproeiingsraad is wat as die Mnyamvubu-besproeiingsraad bekend staan.

Gegee onder my Hand en die Seël van die Republiek van Suid-Afrika te Pretoria, op hede die Vyftiende dag van Mei Eenduisend Negehonderd Vier-en-tagtig.

M. VILJOEN, Staatspresident.

Op las van die Staatspresident-in-rade:

S. A. S. HAYWARD.

BYLAE**BESKRYWING VAN DIE EIENDOMME WAT DIE MNYAMVUBU - BESPROEIINGSDISTRIK, DISTRIK UMVOTI, NATAL, UITMAAK**

Dartmoor 5093.

Scawby 4211.

Bloemendal 1144.

Riet Vlei 3281.

Gedeelte 11 van Craigie Burn 1277.

Die volgende gedeeltes van Balmoral 13347:

Gedeeltes 1, 2, 5, 6, 7, 8 en Restant.

'n Plan wat bostaande gebiedsbeskrywing toon, verskyn hieronder.

No. 90, 1984

MNYAMVUBU IRRIGATION DISTRICT, DISTRICT OF UMVOTI, NATAL.—ESTABLISHMENT

Whereas owners of land riparian to the Mnyamvubu River have, in terms of section 71 (1) of the Water Act, 1956 (Act 54 of 1956), submitted to the Minister of Environment Affairs and Fisheries a petition stating that, in the opinion of the petitioners, it is desirable that the distribution and use of water of the Mnyamvubu River be specially controlled;

And whereas all the provisions of the said Act relating to such petition have been complied with;

And whereas the State President may, in terms of section 74 (1) of the said Act, upon the recommendation of the Minister of Environment Affairs and Fisheries, declare an area to be an irrigation district and the said Minister has furnished such recommendation in terms of section 72 (3) (a) of the said Act;

Now, therefore, under and by virtue of the powers vested in me by section 74 (1) of the said Act, I hereby declare that the area described in the Schedule hereto shall constitute an irrigation district, to be known as the Mnyamvubu Irrigation District;

And, under and by virtue of the powers vested in me by section 79 (1) of the said Act, I hereby further declare that there shall be an irrigation board for the said irrigation district, to be known as the Mnyamvubu Irrigation Board.

Given under my Hand and the Seal of the Republic of South Africa at Pretoria this Fifteenth day of May, One thousand Nine hundred and Eighty-four.

M. VILJOEN, State President.

By Order of the State President-in-Council:

S. A. S. HAYWARD.

SCHEDULE**DESCRIPTION OF THE PROPERTIES CONSTITUTING THE MNYAMVUBU IRRIGATION DISTRICT, DISTRICT OF UMVOTI, NATAL**

Dartmoor 5093.

Scawby 4211.

Bloemendal 1144.

Riet Vlei 3281.

Portion 11 of Craigie Burn 1277.

The following Portions of Balmoral 13347:

Portions 1, 2, 5, 6, 7, 8 and Remainder.

A plan showing the above-mentioned area appears below.

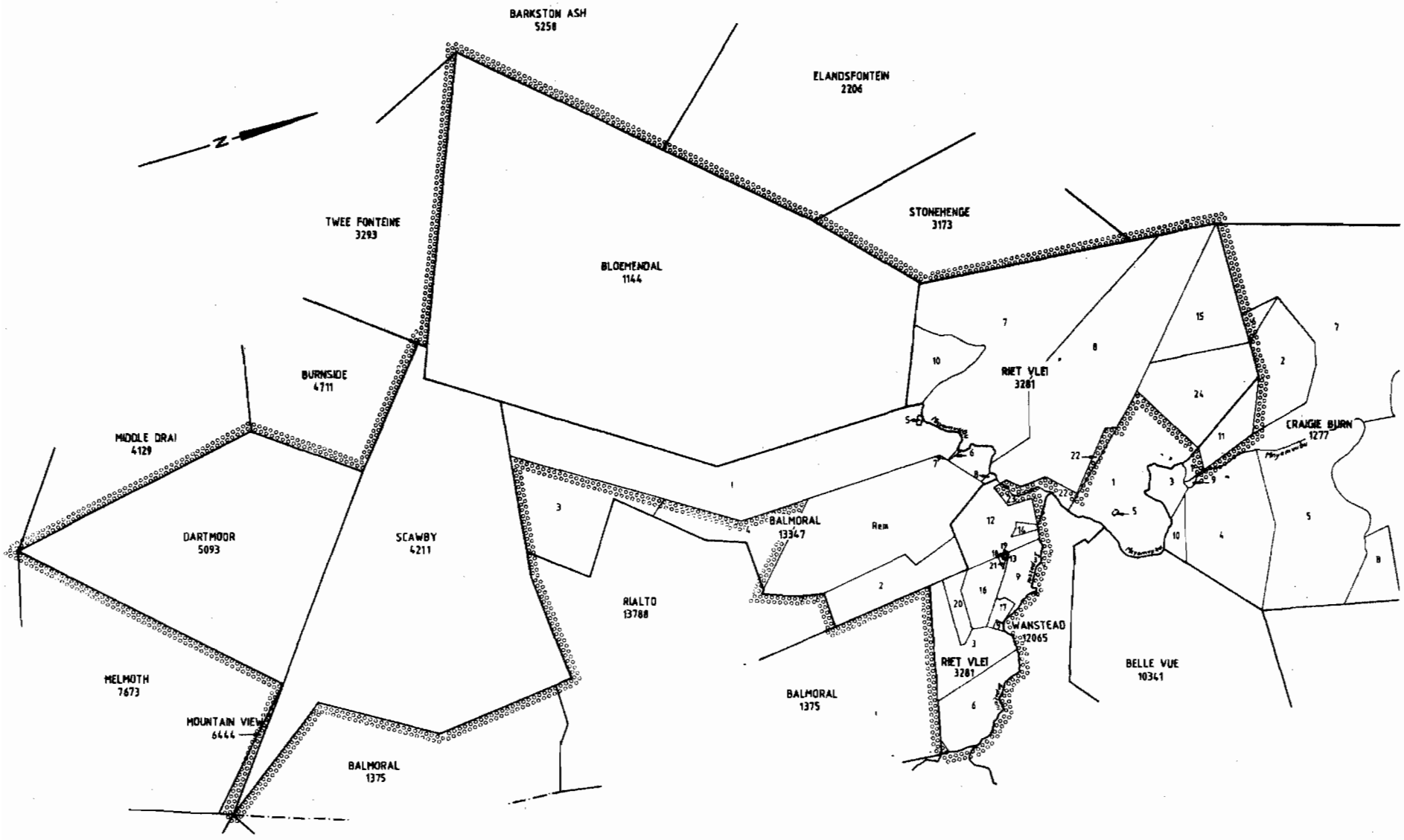

Skaal/Scale

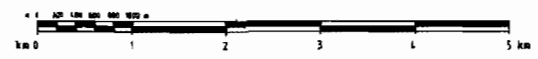

No. 91, 1984

DATUM VAN INWERKINGTREDING VAN DIE WYSIGINGSWET OP DIE WETTE OP VREEMDELINGE EN IMMIGRASIE, 1984

Kragtens artikel 42 van die Wysigingswet op die Wette op Vreemdelinge en Immigrasie, 1984 (Wet 49 van 1984), verklaar ek hierby dat genoemde Wet met ingang van 18 Junie 1984 in werking tree.

Gegee onder my Hand en die Seël van die Republiek van Suid-Afrika te Pretoria, op hede die Twee-en-twintigste dag van Mei Eenduisend Negehonderd Vier-en-tagtig.

M. VILJOEN, Staatspresident.

Op las van die Staatspresident-in-rade:

F. W. DE KLERK.

No. 91, 1984

DATE OF COMMENCEMENT OF THE ALIENS AND IMMIGRATION LAWS AMENDMENT ACT, 1984

In terms of section 42 of the Aliens and Immigration Laws Amendment Act, 1984 (Act 49 of 1984), I hereby declare that the said Act shall come into operation with effect from 18 June 1984.

Given under my Hand and the Seal of the Republic of South Africa at Pretoria this Twenty-second day of May, One thousand Nine hundred and Eighty-four.

M. VILJOEN, State President.

By Order of the State President-in-Council:

F. W. DE KLERK.

GOEWERMENTSKENNISGEWINGS

DEPARTEMENT VAN BINNELANDSE AANGELEENTHEDE

No. 1126

8 Junie 1984

AFKEURING VAN ROLPRENT

Die Appèlraad oor Publikasies het kragtens artikel 24 van die Wet op Publikasies, 1974, soos gewysig—

(a) beslis dat die ondergenoemde rolprent binne die bedoeling van artikel 47 (2) (a) van genoemde Wet ongewens is;

(b) die rolprent afgekeur; en

(c) die voorwaardelike goedkeuring van die rolprent deur 'n komitee bedoel in artikel 4 van die genoemde Wet, tersyde gestel.

GOVERNMENT NOTICES

DEPARTMENT OF INTERNAL AFFAIRS

No. 1126

8 June 1984

REJECTION OF FILM

The Publications Appeal Board under section 24 of the Publications Act, 1974, as amended—

(a) decided that the undermentioned film is undesirable within the meaning of section 47 (2) (a) of the said Act;

(b) rejected the film; and

(c) set aside the conditional approval of the film by a committee referred to in section 4 of the said Act.

Inskrywing No. Entry No.	Rolprent Film	Vertoëmaker Representer
R84/2/183	<i>Swinging Barmaids</i>	Permanent Video Distributors.

No. 1127

8 Junie 1984

ONGEWENSTE PUBLIKASIES OF VOORWERPE

'n Komitee bedoel in artikel 4 van die Wet op Publikasies, 1974, soos gewysig, het kragtens artikel 11 (2) van genoemde Wet beslis dat die ondergenoemde publikasies of voorwerpe ongewens is binne die bedoeling van artikel 47 (2) van genoemde Wet:

No. 1127

8 June 1984

UNDESIRABLE PUBLICATIONS OR OBJECTS

A committee referred to in section 4 of the Publications Act, 1974, as amended, decided under section 11 (2) of the said Act that the undermentioned publications or objects are undesirable within the meaning of section 47 (2) of the said Act:

LYS/LIST P84/49

Inskrywing No. Entry No.	Publikasie of voorwerp Publication or object	Skrywer of voortbringer Author or producer	Artikel 47 (2) Section 47 (2)
P84/5/29	<i>Stern</i> —Nr 13, Jahr 22, März 1984	Gruner & Jahr AG Co, Hamburg	(a)
P84/5/32	<i>Thinking Of You</i> —No V 710-100 (Groetekaart/ Greeting Card)	Rockshots Inc, New York	(a)
P84/5/33	<i>Write Me, You Prick!</i> —No 259-1.00 (Groetekaart/ Greeting Card)	TNT Designs Inc, New York	(a)
P84/5/34	<i>Playgirl Cards</i> —No PY 015-100 (Groetekaart/ Greeting Card)	Paper Moon Graphics Inc Los Angeles, California	(a)
P84/5/35	<i>Get F . . .</i> —No QB 954-90 (Groetekaart/ Greeting Card)	Rockshots Inc, New York	(a)
P84/5/36	<i>Cum Clean!</i> —No 260-1.00 (Groetekaart/ Greeting Card)	TNT Designs Inc., New York	(a)
P84/5/42	<i>Sally</i> —No 118/1752 (Plakkaat/Poster)	Printed in Scotland by Holmes McDougall Limited, Edinburgh	(a)
P84/5/43	<i>Petticoat Girls</i> —No 245/101703 (Plakkaat/Poster) ...	Printed in Scotland by Holmes McDougall Limited, Edinburgh	(a)
P84/5/44	<i>Nicky</i> —No EPG 054 (Plakkaat/Poster)	Printed in The Netherlands	(a)
P84/5/45	<i>Lindsey In Her Diving Suit</i> —No EPG 052 (Plakkaat/Poster)	Printed in The Netherlands	(a)
P84/5/46	<i>Jane In The Jungle</i> —No EPG 051 (Plakkaat/Poster)	Printed in The Netherlands	(a)
P84/5/47	<i>Foxy Lady</i> —No 142/1753 (Plakkaat/Poster)	Printed in Scotland by Holmes, McDougall Limited, Edinburgh	(a)

Inskrywing No. Entry No.	Publikasie of voorwerp Publication or object	Skyrwer of voortbringer Author or producer	Artikel 47 (2) Section 47 (2)
P84/5/48	<i>Fighter Pilot</i> —No 210/1763 (Plakkaat/Poster)	Printed in Scotland by Holmes, McDougall Limited, Edinburgh	(a)
P84/5/49	<i>Charlotte</i> —No EPG 056 (Plakkaat/Poster)	Printed in The Netherlands	(a)
P84/5/50	<i>Angle</i> —No EPG 053 (Plakkaat/Poster)	Printed in The Netherlands	(a)
P84/5/52	<i>Halfnaakte meisie geklee in wit baadjie en broekie/ Semi-nude girl dressed in white jacket and pants</i> (Plakkaat/Poster)	Nie vermeld nie/Not stated	(a)
P84/5/94	<i>Smile! I'm Ready to Shoot</i> —No 258-1.00 (Groetekaart/Greeting Card)	TNT Designs Inc, New York	(a)
P84/5/95	<i>Pussycat</i> —No 281-1.00 (Groetekaart/Greeting Card)	TNT Designs Inc, New York	(a)
P84/5/96	<i>Mr Piggy</i> —No 282-1.00 (Groetekaart/Greeting Card)	TNT Designs Inc, New York	(a)
P84/5/97	<i>Hey, Hot Stuff</i> (Rubber)—No TNT 424-90	TNT Designs Inc, New York	(a)
P84/5/98	<i>Sexual Acrobatics</i> —No 419-90 (Groetekaart/Greeting Card)	TNT Designs Inc, New York	(a)
P84/5/100	<i>Life Is Not A Cabaret</i> —No 402-90 (Groetekaart/Greeting Card)	TNT Designs Inc, New York	(a)
P84/5/101	<i>Girl In Blue Coat</i> —No 6443 (Plakkaat/Poster)	Printed in The Netherlands	(a)

No. 1128

8 Junie 1984

VERBOD OP BESIT VAN ONGEWENSTE PUBLIKASIES OF VOORWERPE

'n Komitee bedoel in artikel 4 van die Wet op Publikasies, 1974, soos gewysig, wat kragtens artikel 11 (2) van genoemde Wet beslis het dat die ondergenoemde publikasies ongewens is binne die bedoeling van artikel 47 (2) van genoemde Wet, het kragtens artikel 9 (3) van genoemde Wet die besit van genoemde publikasies verbied. Genoemde verbod is kragtens artikel 9 (5) van genoemde Wet deur die Appèlraad oor Publikasies bekragtig.

No. 1128

8 June 1984

PROHIBITION ON POSSESSION OF UNDESIRABLE PUBLICATIONS OR OBJECTS

A committee referred to in section 4 of the Publications Act, 1974, as amended, which decided under section 11 (2) of the said Act, that the undermentioned publications are undesirable within the meaning of section 47 (2) of the said Act, has under section 9 (3) of the said Act, prohibited the possession of the said publications. The said prohibition was confirmed by the Publications Appeal Board under section 9 (5) of the said Act.

Inskrywing No. Entry No.	Publikasie Publication	Skyrwer of voortbringer Author or producer	Artikel 47 (2) Section 47 (2)
P84/3/38	<i>News</i> —No 2/84	German Democratic Republic, Berlin	(e)
P84/3/113	<i>SASCO</i> —Vol 1, No 5, January 1984	Issued by Black Consciousness Movement Azania, Washington	(a)
P84/3/127	<i>Welcome Back Comrade Billy Nair</i>	Issued by NIC and AFCWU	(e)
P84/3/134	<i>Christina's Nights</i>	Blakely St. James	(a)
P84/3/136	<i>Inqaba Ya Basebenzi</i> —No 12, November 1983/ February 1984 with Supplement—No 12, November 1983/February 1984	Inqaba Ya Basebenzi, London	(e)
P84/3/147	<i>Workers' Unity</i> —No 38, 1983; No 39, 1984 with Supplement No 39, 1984	South African Congress of Trade Unions, London...	(e)
P84/3/148	<i>World Marxist Review</i> —Vol 27, No 2, February 1984	S C Easton, London	(e)
P84/3/169	<i>Mind Over Mattress</i>	Margot Peters	(a)
P84/3/170	<i>Jennifer</i> —Book Seven	Dell Publishing Co, New York	(a)
P84/3/171	<i>Christina's Passion</i>	Blakely St. James	(a)
P84/3/172	<i>Girls From Orgy, The</i>	Ted Mark	(a)
P84/3/186	<i>Sechaba</i> —February 1984	African National Congress Lusaka, Zambia	(e)
P84/4/13	<i>News Times</i> —No 7, February 1984	Trud, Moscow	(e)

No. 1129

8 Junie 1984

PUBLIKASIES OF VOORWERPE.—VERTOË TEN OPSIGTE VAN APPEL

Die Direktooraat van Publikasies het op 23 Mei 1984 kragtens artikel 14 van die Wet op Publikasies, 1974, appèl aangeteken teen die beslissing op 17 Mei 1984 van 'n komitee bedoel in artikel 4 van genoemde Wet dat die ondergenoemde publikasie nie binne die bedoeling van artikel 47 (2) van genoemde Wet ongewens is nie. Die tydperk waarin persone bedoel in artikel 14 (3) (b) van genoemde Wet verhoë tot die Appèlraad oor Publikasies, Privaatsak X114, Pretoria, ten opsigte van genoemde appèl kan rig, word hierby bepaal as tien (10) dae vanaf die datum van hierdie kennisgewing.

No. 1129

30 June 1984

PUBLICATIONS OR OBJECTS.—REPRESENTATIONS IN RESPECT OF APPEAL

On 23 May 1984 the Directorate of Publications appealed under section 14 of the Publications Act, 1974, against the decision on 17 May 1984 of a committee referred to in section 4 of the said Act, that the undermentioned publication is not undesirable within the meaning of section 47 (2) of the said Act. The period within which persons referred to in section 14 (3) (b) of the said Act may make representations to the Publications Appeal Board, Private Bag X114, Pretoria, in respect of the said appeal is hereby determined as ten (10) days from the date of this notice.

Inskrywing No. Entry No.	Publikasie of voorwerp Publication or object	Skyrwer of voortbringer Author or producer
P84/5/31	<i>You're all Heart!</i> —No V708-100 (Groetekaart/Greeting card)	Rockshots Inc, New York.
P84/5/37	<i>Face it Fella</i> —No PH-827-100 (Groetekaart/Greeting card)	Rockshots Inc, New York.
P84/5/39	<i>You are cordially invited to . . .</i> (Vuurhoutjieshouer/Matches holder: Voorwerp/Object)	Striking Images Inc, Canada.

No. 1140

8 Junie 1984

WET OP VREEMDELINGE, 1937

VANSVERANDERING.—KOK IN RANDSTON

Dit het die Minister van Binnelandse Aangeleenthede behaag om, kragtens die bepalings van artikel 9 van die Wet op Vreemdelinge, 1937 (Wet 1 van 1937) David Johan Kok, sy vrou Dawn en sy kinders Andrew David en Michelle Dawn, woonagtig te Centralstraat 94, Jacanlee, Randburg, te magtig om die van Randston aan te neem.

**DEPARTEMENT VAN BUITELANDSE
SAKE**

No. 1158

8 Junie 1984

GELOOFSBRIEFOORHANDIGING

Hierby word bekendgemaak dat Sy Eksellensie dr. José Manuel Peixoto de Vilas Boas de Vasconcelos Faria op Donderdag, 24 Mei 1984, om 11h00, aan Groote Schuur, Rondebosch, Kaapstad, deur die Staatspresident ontvang is en dat hy by daardie geleentheid sy Geloofsbrief as Buitengewone en Gevolmagtigde Ambassadeur van Portugal in die Republiek van Suid-Afrika oorhandig het.

[72/14/1 (301)]

DEPARTEMENT VAN FINANSIES

No. 1115

8 Junie 1984

Hiermee word bekendgemaak dat die oordragboeke van ondergenoemde plaaslike/binnelandse geregistreerde effekte van 15 Junie 1984 tot en met 15 Julie 1984 gesluit sal wees en dat die rente betaalbaar op 15 Julie 1984 aan die effektebesitters wat op die datum van sluiting van die oordragboeke geregistreer is, betaal sal word:

Plaaslike Geregistreerde Effekte, 6,50 Persent, 1993.

Binnelandse Geregistreerde Effekte, 9,80 Persent, 2001.

Binnelandse Geregistreerde Effekte, 13,00 Persent, 2005.

Binnelandse Geregistreerde Effekte, 14,00 Persent, 1992.

**DEPARTEMENT VAN GEMEEN-
SKAPSONTWIKKELING**

No. 1149

8 Junie 1984

WET OP HUURBEHEER, 1976

VERKLARING DAT 'N SEKERE WONING, MOTORHUIS EN BEDIENDEKAMER VAN HUURBEHEER ONTHEF IS

Kragtens die bevoegdheid my verleen by artikel 51 (g) van die Wet op Huurbeheer, 1976 (Wet 80 van 1976), verklaar ek, Pierre Cronjé, Adjunk-minister van Gemeenskapsontwikkeling, hiermee dat—

(a) die woning genoem in die Bylae hiervan; en

(b) die motorhuis en bediendekamer geleë op enige plek op grond wat deel uitmaak van grond wat geokkuper word deur of gebruik word in verband met die woning in (a) hierbo genoem,

vanaf die datum van publikasie hiervan, van huurbeheer onthef is.

P. CRONJÉ, Adjunk-minister van
Gemeenskapsontwikkeling.

BYLAE

Adres van eiendom.—Arbourweg 31, Glen Barry, George.

Ligging van eiendom.—Erf 5012, George.

No. 1140

8 June 1984

ALIENS ACT, 1937

CHANGE OF SURNAME.—KOK TO RANDSTON

The Minister of Internal Affairs has been pleased under the provisions of section 9 of the Aliens Act, 1937 (Act 1 of 1937), to authorise David Johan Kok, his wife Michelle Dawn and his children Andrew David and Michelle Dawn, residing at 94 Central Road, Jacanlee, Randburg, to assume the surname of Randston.

**DEPARTMENT OF FOREIGN
AFFAIRS**

No. 1158

8 June 1984

PRESENTATION OF CREDENTIALS

It is hereby notified that His Excellency Dr José Manuel Peixoto de Vilas Boas de Vasconcelos Faria was received by the State President at Groote Schuur, Rondebosch, Cape Town, on Thursday, 24 May 1984, at 11h00, on which occasion he presented his Letter of Credence as Ambassador Extraordinary and Plenipotentiary of Portugal to the Republic of South Africa.

[72/14/1 (301)]

DEPARTMENT OF FINANCE

No. 1115

8 June 1984

Notice is hereby given that the transfer books of the un-dermentioned local/internal registered stocks will be closed from 15 June 1984 to 15 July 1984, both days inclusive, and that the interest due on 15 July 1984, will be paid to the stockholders registered at the date of the closing of the transfer books:

Local Registered Stock, 6,50 Per Cent, 1993.

Internal Registered Stock, 9,80 Per Cent, 2001.

Internal Registered Stock, 13,00 Per Cent, 2005.

Internal Registered Stock, 14,00 Per Cent, 1992.

**DEPARTMENT OF COMMUNITY
DEVELOPMENT**

No. 1149

8 June 1984

RENT CONTROL ACT, 1976

DECLARATION THAT A CERTAIN DWELLING, GARAGE AND SERVANT'S ROOM ARE EXEMPTED FROM RENT CONTROL

Under the powers vested in me by section 51 (g) of the Rent Control Act, 1976 (Act 80 of 1976), I, Pierre Cronjé, Deputy Minister of Community Development, hereby declare that—

(a) the dwelling mentioned in the Schedule hereto; and

(b) the garage and servant's room situated anywhere upon land forming part of land occupied by or used in connection with the dwelling mentioned in (a) above.

are exempted from rent control as from date of publication hereof.

P. CRONJÉ, Deputy Minister of
Community Development.

SCHEDULE

Address of premises.—31 Arbour Road, Glen Barry, George.

Situation of premises.—Erf 5012, George.

No. 1150

8 Junie 1984

WET OP HUURBEHEER, 1976

VERKLARING DAT SEKERE WONINGS, MOTORSTAAANPLEKKE EN BEDIENDEKAMERS VAN HUURBEHEER ONTHEF IS

Kragtens die bevoegdheid my verleen by artikel 51 (g) van die Wet op Huurbeheer, 1976 (Wet 80 van 1976), verklaar ek, Pierre Cronjé, Adjunk-minister van Gemeenskapsontwikkeling, hiermee dat—

(a) die wonings in die woonstelgebou genoem in die Bylae hiervan; en

(b) die motorstaanplekke en bediendekamers geleë op enige plek op grond wat deel uitmaak van grond wat geokkupeer word deur of gebruik word in verband met die wonings in (a) hierbo genoem,

vanaf die datum van publikasie hiervan, van huurbeheer onthef is.

P. CRONJÉ, Adjunk-minister van
Gemeenskapsontwikkeling.

BYLAE

Adres van eiendom.—Shirley Court, Johannesburgweg 254, La Rochelle, Johannesburg.

Ligging van eiendom.—Gekonsolideerde Erf 622, La Rochelle, Johannesburg.

No. 1151

8 Junie 1984

WET OP HUURBEHEER, 1976

WYSIGING VAN GOEWERMENSKENNISGEWING 2285 VAN 14 OKTOBER 1983 INGEVOLGE WAARVAN SEKERE WONINGS, MOTORHUISE EN BEDIENDEKAMERS VAN HUURBEHEER ONTHEF IS

Kragtens die bevoegdheid my verleen by artikel 51 (g) van die Wet op Huurbeheer, 1976 (Wet 80 van 1976), wysig ek, Pierre Cronjé, Adjunk-minister van Gemeenskapsontwikkeling, hiermee Goewermenskennisgewing 2285 van 14 Oktober 1983 deur die skraping van die volgende woorde:

“op voorwaarde dat 'n deeltitelregister binne nege maande geopen word, of binne sodanige verlengde tydperk as waartoe op aansoek ingestem mag word.”.

P. CRONJÉ, Adjunk-minister van
Gemeenskapsontwikkeling.

No. 1152

8 Junie 1984

WET OP HUURBEHEER, 1976

VERKLARING DAT SEKERE WONINGS, MOTORSTAAANPLEKKE EN BEDIENDEKAMERS VAN HUURBEHEER ONTHEF IS

Kragtens die bevoegdheid my verleen by artikel 51 (g) van die Wet op Huurbeheer, 1976 (Wet 80 van 1976), verklaar ek, Pierre Cronjé, Adjunk-minister van Gemeenskapsontwikkeling, hiermee dat—

(a) die wonings in die woonstelgebou genoem in die Bylae hiervan; en

(b) die motorstaanplekke en bediendekamers geleë op enige plek op grond wat deel uitmaak van grond wat geokkupeer word deur of gebruik word in verband met die wonings in (a) hierbo genoem,

vanaf die datum van publikasie hiervan, van huurbeheer onthef is.

P. CRONJÉ, Adjunk-minister van
Gemeenskapsontwikkeling.

No. 1150

8 June 1984

RENT CONTROL ACT, 1976

DECLARATION THAT CERTAIN DWELLINGS, PARKING SPACES AND SERVANTS' ROOMS ARE EXEMPTED FROM RENT CONTROL

Under the powers vested in me by section 51 (g) of the Rent Control Act, 1976 (Act 80 of 1976), I, Pierre Cronjé, Deputy Minister of Community Development, hereby declare that—

(a) the dwellings in the block of flats mentioned in the Schedule hereto; and

(b) the parking spaces and servants' rooms situated anywhere upon land forming part of land occupied by or used in connection with the dwellings mentioned in (a) above,

are exempted from rent control as from date of publication hereof.

P. CRONJÉ, Deputy Minister of
Community Development.

SCHEDULE

Address of premises.—Shirley Court, 254 Johannesburg Road, La Rochelle, Johannesburg.

Situation of premises.—Consolidated Stand 622, La Rochelle, Johannesburg.

No. 1151

8 June 1984

RENT CONTROL ACT, 1976

AMENDMENT OF GOVERNMENT NOTICE 2285 OF 14 OCTOBER 1983 IN TERMS OF WHICH CERTAIN DWELLINGS, GARAGES AND SERVANTS' ROOMS ARE EXEMPTED FROM RENT CONTROL

Under the powers vested in me by section 51 (g) of the Rent Control Act, 1976 (Act 80 of 1976), I, Pierre Cronjé, Deputy Minister of Community Development, hereby amend Government Notice 2285 of 14 October 1983 by deleting the following words:

“on condition that a sectional title register is opened within nine months, or within such extended period as may be agreed to on application.”.

P. CRONJÉ, Deputy Minister of
Community Development.

No. 1152

8 June 1984

RENT CONTROL ACT, 1976

DECLARATION THAT CERTAIN DWELLINGS, PARKING SPACES AND SERVANTS' ROOMS ARE EXEMPTED FROM RENT CONTROL

Under the powers vested in me by section 51 (g) of the Rent Control Act, 1976 (Act 80 of 1976), I, Pierre Cronjé, Deputy Minister of Community Development, hereby declare that—

(a) the dwellings in the block of flats mentioned in the Schedule hereto; and

(b) the parking spaces and servants' rooms situated anywhere upon land forming part of land occupied by or used in connection with the dwellings mentioned in (a) above,

are exempted from rent control as from date of publication hereof.

P. CRONJÉ, Deputy Minister of
Community Development.

BYLAE

Adres van eiendom.—Dafield Court, Yeostraat 6, Yeoville, Johannesburg.

Ligging van eiendom.—Erf 1241, Yeoville, Johannesburg.

No. 1153 **8 Junie 1984**

WET OP HUURBEHEER, 1976

VERKLARING DAT 'N SEKERE WONING VAN HUURBEHEER ONTHEF IS

Kragtens die bevoegdheid my verleen by artikel 51 (g) van die Wet op Huurbeheer, 1976 (Wet 80 van 1976), verklaar ek, Pierre Cronjé, Adjunk-minister van Gemeenskapsontwikkeling, hierby dat die woning genoem in die Bylae hiervan, vanaf die datum van publikasie hiervan, van huurbeheer onthef is, op voorwaarde dat die geregistreerde eienaar die huidige huurder drie (3) maande kennis gee om te ontruim en die woonstel daarna vir 'n onafgebroke tydperk van minstens twaalf (12) maande okkupeer vanaf datum van ontruiming deur die huidige huurder.

P. CRONJÉ, Adjunk-minister van Gemeenskapsontwikkeling.

BYLAE

Adres van eiendom.—Woonstel 7, St Claire Court, High Levelweg 263, Seepunt, Kaapstad.

Ligging van eiendom.—Erf 1539, Kaapstad te Seepunt.

No. 1154 **8 Junie 1984**

WET OP HUURBEHEER, 1976

VERKLARING DAT SEKERE WONINGS, MOTORHUISE EN BEDIENDEKAMERS VAN HUURBEHEER ONTHEF IS

Kragtens die bevoegdheid my verleen by artikel 51 (g) van die Wet op Huurbeheer, 1976 (Wet 80 van 1976), verklaar ek, Pierre Cronjé, Adjunk-minister van Gemeenskapsontwikkeling, hiermee dat—

(a) die wonings genoem in die Bylae hiervan; en

(b) die motorhuise en bediendekamers geleë op enige plek op grond wat deel uitmaak van grond wat geokkupeer word deur of gebruik word in verband met die wonings in (a) hierbo genoem,

vanaf die datum van publikasie hiervan, van huurbeheer onthef is.

P. CRONJÉ, Adjunk-minister van Gemeenskapsontwikkeling.

BYLAE

Adres van eiendom.—Windmillweg 97/97a, Durban.

Ligging van eiendom.—Restant van 1 van Onderverdeling A van Perseel 7, Blok Z, van die Dorpsgronde van Durban 1737, geleë in die stad en graafskap Durban, provinsie Natal.

No. 1155 **8 Junie 1984**

WET OP HUURBEHEER, 1976

VERKLARING DAT 'N SEKERE WONING, MOTORHUISE EN BEDIENDEKAMERS VAN HUURBEHEER ONTHEF IS

Kragtens die bevoegdheid my verleen by artikel 51 (g) van die Wet op Huurbeheer, 1976 (Wet 80 van 1976), verklaar ek, Pierre Cronjé, Adjunk-minister van Gemeenskapsontwikkeling, hiermee dat—

(a) die woning genoem in die Bylae hiervan; en

SCHEDULE

Address of premises.—Dafield Court, 6 Yeo Street, Yeoville, Johannesburg.

Situation of premises.—Erf 1241, Yeoville, Johannesburg.

No. 1153 **8 June 1984**

RENT CONTROL ACT, 1976

DECLARATION THAT A CERTAIN DWELLING IS EXEMPTED FROM RENT CONTROL

Under the powers vested in me by section 51 (g) of the Rent Control Act, 1976 (Act 80 of 1976), I, Pierre Cronjé, Deputy Minister of Community Development, hereby declare that the dwelling mentioned in the Schedule hereto, is exempted from rent control as from date of publication hereof, on condition that the registered owner gives the tenant three (3) months' notice to vacate and he thereafter occupies the flat for an uninterrupted period of at least twelve (12) months from date of vacation by the present tenant.

P. CRONJÉ, Deputy Minister of Community Development.

SCHEDULE

Address of premises.—Flat 7, St Claire Court, 263 High Level Road, Sea Point, Cape Town.

Situation of premises.—Erf 1539, Cape Town at Sea Point.

No. 1154 **8 June 1984**

RENT CONTROL ACT, 1976

DECLARATION THAT CERTAIN DWELLING, GARAGES AND SERVANTS' ROOMS ARE EXEMPTED FROM RENT CONTROL

Under the powers vested in me by section 51 (g) of the Rent Control Act, 1976 (Act 80 of 1976), I, Pierre Cronjé, Deputy Minister of Community Development, hereby declare that—

(a) the dwelling mentioned in the Schedule hereto; and

(b) the garages and servants' rooms situated anywhere upon land forming part of land occupied by or used in connection with the dwellings mentioned in (a) above,

are exempted from rent control as from date of publication hereof.

P. CRONJÉ, Deputy Minister of Community Development.

SCHEDULE

Address of premises.—97/97a Windmill Road, Durban.

Situation of premises.—Remainder of 1 of Subdivision A of Lot 7, Block Z of the Townlands of Durban 1737, situate in the City and County of Durban, Province of Natal.

No. 1155 **8 June 1984**

RENT CONTROL ACT, 1976

DECLARATION THAT A CERTAIN DWELLING, GARAGES AND SERVANTS' ROOMS ARE EXEMPTED FROM RENT CONTROL

Under the powers vested in me by section 51 (g) of the Rent Control Act, 1976 (Act 80 of 1976), I, Pierre Cronjé, Deputy Minister of Community Development, hereby declare that—

(a) the dwelling mentioned in the Schedule hereto; and

(b) die motorhuise en bediendekamers geleë op enige plek op grond wat deel uitmaak van grond wat geokkupeer word deur of gebruik word in verband met die woning in (a) hierbo genoem,

vanaf die datum van publikasie hiervan, van huurbeheer onthef is.

P. CRONJÉ, Adjunk-minister van
Gemeenskapontwikkeling.

BYLAE

Adres van eiendom.—Coweyweg 183, Durban.

Ligging van eiendom:

(i) Onderverdeling 1 van Perseel 71, Blok B, van die Dorpsgronde van Durban 1737, geleë in die stad en graafskap Durban, provinsie Natal; en

(ii) Onderverdeling 2 van Perseel 71, Blok B, van die Dorpsgronde van Durban 1737, geleë in die stad en graafskap Durban, provinsie Natal.

(b) the garages and servants' rooms situated anywhere upon land forming part of land occupied by or used in connection with the dwelling mentioned in (a) above,

are exempted from rent control as from date of publication hereof.

P. CRONJÉ, Deputy Minister of
Community Development.

SCHEDULE

Address of premises.—183 Cowey Road, Durban.

Situation of premises:

(i) Subdivision 1 of Lot 71, Block B, of the Townlands of Durban 1737, situate in the City and County of Durban, Province of Natal; and

(ii) Subdivision 2 of Lot 71, Block B, of the Townlands of Durban 1737, situate in the City and County of Durban, Province of Natal.

DEPARTEMENT VAN LANDBOU

No. 1118

8 Junie 1984

WET OP ONDERVERDELING VAN LANDBOU-GROND, 1970 (WET 70 VAN 1970)

UITSLUITING VAN SEKERE GROND IN DIE AFDELING OUTENIQUA VAN DIE TOEPASSING VAN DIE WET

Ek, Gert Jeremias Kotzé, Adjunk-minister van Landbou, handelende namens die Minister van Landbou, sluit hierby kragtens paragraaf (f) van die woordomskrywing van "landbougrond" in artikel 1 van die Wet op Onderverdeling van Landbougrond, 1970 (Wet 70 van 1970), na oorlegging met die Uitvoerende Komitee van die provinsie die Kaap die Goeie Hoop, die gebied in die Bylae beskryf, uit van die bepalings van genoemde Wet.

G. J. KOTZÉ, Adjunk-minister van Landbou.

BYLAE

Begin by die noordelike baken van Gedeelte 49 van die plaas Kraai Bosch 195, administratiewe distrik George; daarvandaan suidooswaarts met die grense van die volgende plase langs om hulle in hierdie gebied in te sluit, nl. genoemde Gedeelte 49, Gedeeltes 50, 51, 45, 46, 66, 67, 68, 69, 70, 10, 11, 60, 74, 110, genoemde Gedeelte 74, Gedeeltes 64 en 86, almal gedeeltes van genoemde plaas Kraai Bosch 195, tot by die noordelike baken van laasgenoemde Gedeelte 86; daarvandaan noordooswaarts met die grense van Gedeeltes 79 en 15 van genoemde plaas Kraai Bosch 195 langs om hulle uit hierdie gebied uit te sluit tot by die suidelike baken van laasgenoemde Gedeelte 15; daarvandaan suidwaarts in 'n reguit lyn tot by die suidelike punt van Gedeelte 89 van genoemde plaas Kraai Bosch 195; daarvandaan algemeen suidweswaarts met die grense van die volgende plase langs om dit in hierdie gebied in te sluit, nl. genoemde Gedeelte 89, genoemde plaas Kraai Bosch 195, Gedeeltes 14, 18, 102, genoemde Gedeeltes 18, 74, 60, 11, 10, 70, 69, 68, 67, 66, 46, 45, 51, 50, en 49 tot by eersgenoemde baken.

DEPARTMENT OF AGRICULTURE

No. 1118

8 June 1984

SUBDIVISION OF AGRICULTURAL LAND ACT, 1970 (ACT 70 OF 1970)

EXCLUSION OF CERTAIN LAND IN THE DIVISION OF OUTENIQUA FROM THE APPLICATION OF THE ACT

I, Gert Jeremias Kotzé, Deputy Minister of Agriculture, acting on behalf of the Minister of Agriculture, hereby exclude by virtue of paragraph (f) of the definition of "agricultural land" in section 1 of the Subdivision of Agricultural Land Act, 1970 (Act 70 of 1970), after consultation with the Executive Committee of the Province of the Cape of Good Hope, the land described in the Schedule from the provisions of the said Act.

G. J. KOTZÉ, Deputy Minister of Agriculture.

SCHEDULE

Beginning at the northernmost beacon of Portion 49 of the farm Kraai Bosch 195, Administrative District of George; thence south-eastwards along the boundaries of the following farms so as to include them in this area, viz the said Portion 49, Portions 50, 51, 45, 46, 66, 67, 68, 69, 70, 10, 11, 60, 74, 110, the said Portion 74, Portions 64 and 86, all portions of the said farm Kraai Bosch 195, to the northernmost beacon of the last-mentioned Portion 86; thence north-eastwards with the boundaries of Portions 79 and 15 of the said farm Kraai Bosch 195, so as to exclude them from this area to the southernmost beacon of the last-mentioned Portion 15; thence southwards in a straight line to the southernmost point of Portion 89 of the said farm Kraai Bosch 195; thence generally south-westwards along the boundaries of the following farms so as to include them in this area, viz the said Portion 89, the said farm Kraai Bosch 195, Portion 14, 18, 102, the said Portions 18, 74, 60, 11, 10, 70, 69, 68, 67, 66, 46, 45, 51, 50, and 49 to the beacon first named.

DEPARTEMENT VAN MINERAAL- EN ENERGIESAKE

No. 1116

8 Junie 1984

VERKLARING VAN WERK IN NASIONALE BELANG

Die Minister van Mineraal- en Energiesake het kragtens artikel 9 (1) (f) van die Wet op Myne en Bedrywe, 1956 (Wet 27 van 1956), verklaar dat die verrigting op Sondae

DEPARTMENT OF MINERAL AND ENERGY AFFAIRS

No. 1116

8 June 1984

DECLARATION OF WORK IN NATIONAL INTEREST

The Minister of Mineral and Energy Affairs has, in terms of section 9 (1) (f) of the Mines and Works Act, 1956 (Act 27 of 1956), declared that in his opinion the performance on

van sekere werk, waarvan besonderhede in die Bylae hiervan verskyn, na sy oordeel vir 'n tydperk van drie jaar vanaf 20 Januarie 1984 in nasionale belang nodig is.

BYLAE

Die verwydering van bogrond deur middel van sleepgrawe en bybehorende toerusting by steenkoolmyne in die—

(a) landdrosdistrikte Amersfoort, Bethal, Carolina, Ermelo, Middelburg, Piet Retief, Standerton, Volksrust, Wakkerstroom en Witbank, provinsie Transvaal;

(b) landdrosdistrikte Dannhauser, Dundee, Glencoe, Kliprivier, Newcastle, Paulpietersburg, Utrecht en Vryheid, provinsie Natal; en

(c) landdrosdistrik Sasolburg, provinsie die Oranje-Vrystaat;

waar steenkool volgens oop mynmetodes ontgin word, welke myne as sodanig deur die Staatsmyningenieur geïdentifiseer en geklassifiseer is.

No. 1144 8 Junie 1984

UITSLUITING VAN SEKERE GROND VAN DIE TOEPASSING VAN DIE BEPALINGS VAN HOOFSTUK X EN ARTIKEL 139 (1) VAN DIE WET OP MYNREGTE, 1967 (WET 20 VAN 1967)

Die gedelegeerde van die Minister van Minerale- en Energiesake van die Republiek van Suid-Afrika het kragtens die bevoegdheid hom verleen by artikel 158 (1) van die Wet op Mynregte, 1967 (Wet 20 van 1967), sekere grond, kragtens myntitel gehou, op Gedeeltes 44 en 45 van die plaas Buffelsdoorn 143 IQ, distrik Potchefstroom, myndistrik Klerksdorp, provinsie Transvaal, soos getoon op 'n sketskaart waarvan afdrukke in die Mynbriewekantoor, Johannesburg, en in die Kantoor van die Mynkommissaris, Klerksdorp onder RMT No. R5/82 bewaar word, met ingang van die datum van publikasie hiervan in die *Staatskoerant* uitgesluit van die toepassing van die bepalings van Hoofstuk X en artikel 139 (1) van gemelde Wet.

(19/13/1/349)

No. 1145 8 Junie 1984

GROND VIR DIE AFPENNING VAN KLEIMS OOP VERKLAAR

Die gedelegeerde van die Minister van Minerale- en Energiesake het kragtens artikel 41 (1) van die Wet op Mynregte, 1967 (Wet 20 van 1967), verklaar dat die grond wat voorheen gehou is as kleims, waarvan besonderhede in bygaande Bylae verskyn, vanaf 09h00 op die 27ste dag van Junie 1984 oop is vir die afpenning, kragtens Hoofstuk VI van genoemde Wet, van edelmetalkleims of onedele-mineralekleims, na gelang die grond vir edelmetale of vir onedele minerale geproklameer is.

(18/5/3/8)

Sundays of certain work, details of which appear in the Schedule hereto, is necessary in the national interest for a period of three years from 20 January 1984.

SCHEDULE

The removal of overburden by means of draglines and ancillary equipment at coal mines in the—

(a) Magisterial Districts of Amersfoort, Bethal, Carolina, Ermelo, Middelburg, Piet Retief, Standerton, Volksrust, Wakkerstroom and Witbank, Province of the Transvaal;

(b) Magisterial Districts of Dannhauser, Dundee, Glencoe, Klip River, Newcastle, Paulpietersburg, Utrecht and Vryheid, Province of Natal; and

(c) Magisterial district of Sasolburg, Province of the Orange Free State;

where coal is mined by means of opencast methods, which mines have been identified and classified as such by the Government Mining Engineer.

No. 1144 8 June 1984

EXEMPTION OF CERTAIN LAND FROM THE APPLICATION OF THE PROVISIONS OF CHAPTER X AND SECTION 139 (1) OF THE MINING RIGHTS ACT, 1967 (ACT 20 OF 1967)

The delegate of the Minister of Mineral and Energy Affairs of the Republic of South Africa has under and by virtue of the powers vested in him by section 158 (1) of the Mining Rights Act, 1967 (Act 20 of 1967), exempted certain land, held under mining title, on Portions 44 and 45 of the farm Buffelsdoorn 143 IQ, District of Potchefstroom, Mining District of Klerksdorp, Province of the Transvaal, as shown on a sketch plan, copies of which are filed in the Mining Titles Office, Johannesburg, and in the Office of the Mining Commissioner, Klerksdorp, under RMT No. R5/82, from the application of the provisions of Chapter X and section 139 (1) of the said Act, with effect from the date of publication hereof in the *Gazette*.

(19/13/1/349)

No. 1145 8 June 1984

LAND DECLARED OPEN FOR THE PEGGING OF CLAIMS

The delegate of the Minister of Mineral and Energy Affairs has, in terms of section 41 (1) of the Mining Rights Act, 1967 (Act 20 of 1967), declared that the land previously held as claims, details of which appear in the Schedule hereto, shall be open from 09h00 on the 27th day of June 1984 for the pegging, in terms of Chapter VI of the said Act, of precious metal claims or base mineral claims according to whether the land has been proclaimed for precious metals or for base minerals.

(18/5/3/8)

BYLAE/SCHEDULE

Lisensienommer Licence number	Onderskeidingsnommers van kleims Distinctive numbers of claims	Getal kleims Number of claims	Kaartnommer Diagram number	Naam van laaste geregistreeerde houer Name of last registered holder	Plaas en distrik Farm and district
MYNDISTRIK PRETORIA/MINING DISTRICT OF PRETORIA					
<i>Onedele-mineralekleims/Base mineral claims</i>					
283	Ongenommer/Unnumbered	50	—	Agatha Maria Walkinshaw	Batavia 176 KP, Thabazimbi.
284	Ongenommer/Unnumbered	50	—	Alfonso Francisco de Vega	Batavia 176 KP, Thabazimbi.
285	Ongenommer/Unnumbered	50	—	Petrus Johannes du Plessis	Batavia 176 KP, Thabazimbi.

No. 1146

8 Junie 1984

UITSLUITING VAN SEKERE GROND VAN DIE TOEPASSING VAN DIE BEPALINGS VAN HOOFSTUK X EN ARTIKEL 139 (1) VAN DIE WET OP MYNREGTE, 1967 (WET 20 VAN 1967)

Die gedelegeerde van die Minister van Minerale- en Energiesake van die Republiek van Suid-Afrika het kragtens die bevoegdheid hom verleen by artikel 158 (1) van die Wet op Mynregte, 1967 (Wet 20 van 1967), sekere grond, kragtens myntitel gehou, op die plaas Therons Rust 69, administratiewe distrik Welkom, myndistrik Oranje-Vrystaat, provinsie die Oranje-Vrystaat, soos getoon op 'n sketskaart waarvan afdrukke in die Mynbriewekantoor, Johannesburg, en in die Kantoor van die Mynkommissaris, O.V.S., Welkom, onder RMT No. R21/84, bewaar word, met ingang van die datum van publikasie hiervan in die Staatskoerant uitgesluit van die toepassing van die bepalings van Hoofstuk X en artikel 139 (1) van gemelde wet.

(19/13/1/346)

DEPARTEMENT VAN NASIONALE OPVOEDING

No. 1117

8 Junie 1984

WET OP OORLOGSGRAFTE EN NASIONALE GEDENKWAARDIGHEDE, No. 28 VAN 1969

VERKLARING VAN DIE EIENDOM MET INBEGRIIP VAN DIE KAFFRARIAN-MUSEUMKOMPLEKS, BESTAANDE UIT DIE OU MUSEUMGEBOU EN DIE DAINES-GEBOU (OU OPENBARE BIBLIOTEEK), DAAROP EN GELEË OP DIE HOEK VAN ALEXANDRA- EN ALBERTWEG, KING WILLIAM'S TOWN

Kragtens die bevoegdheid my verleen by artikel 10 (1) van die Wet op Oorlogsgrafte en Nasionale Gedenkwaardighede, 1969 (Wet 28 van 1969), verklaar ek, Gerrit van Niekerk Viljoen, Minister van Nasionale Opvoeding, hierby die eiendom met inbegrip van die Kaffrarian-museumkompleks, bestaande uit die Ou Museumgebou en die Daines-gebou (ou Openbare Biblioteek), daarop en geleë op die hoek van Alexandra- en Albertweg, King William's Town, tot nasionale gedenkwaardigheid.

Beskrywing

Die eiendom met inbegrip van die Kaffrarian-museumkompleks, bestaande uit die Ou Museumgebou en die Daines-gebou, daarop en geleë op sekere stuk gedeeltelike vrypaggrond en gedeeltelike grond, synde Erf 3363, King William's Town, in die munisipaliteit van die stad van King William's Town, in die afdeling King William's Town en groot tweeduisend negehoonderd ses-en-veertig (2 946) vierkante meter.

Sertifikaat van Verenigde Titel 102/1972, gedateer 24 Januarie 1972.

Historiese en argitektoniese belang

Die Kaffrarian-museum het sy oorsprong by die Natural Historical Society wat in 1884 in King William's Town gestig is. Die oorspronklike museumgebou, ontwerp deur die argitek P. E. Treeby van Johannesburg en op 5 Oktober 1898 deur mev. James Weir geopen, is in 1953 uitgebrei en in 1974 met die Daines-gebou verbind. Laasgenoemde gebou, wat oorspronklik as openbare biblioteek opgerig is deur bemoeiing van Thomas Daines, 'n apteker by Grey-hospitaal, is deur die argitek S. Stent ontwerp en op 23 Julie 1877 geopen.

Hierdie twee Laat-Victoriaanse geboue wat verbind is om die Kaffrarian-museumkompleks te vorm, weerspieël Klassieke en Neo-Gotiese kenmerke. Die museum self is welbekend vir sy manjifieke soogdierversameling, die grootste in sy soort in Suid-Afrika. 10/2/1111.

G. VAN N. VILJOEN, Minister van Nasionale Opvoeding.

No. 1146

8 June 1984

EXEMPTION OF CERTAIN LAND FROM THE APPLICATION OF THE PROVISIONS OF CHAPTER X AND SECTION 139 (1) OF THE MINING RIGHTS ACT, 1967 (ACT 20 OF 1967)

The delegate of the Minister of Mineral and Energy Affairs of the Republic of South Africa has, under and by virtue of the powers vested in him by section 158 (1) of the Mining Rights Act, 1967 (Act 20 of 1967), exempted certain land held under mining title on the farm Therons Rust 69, Administrative District of Welkom, Mining District of the Orange Free State, Province of the Orange Free State, as shown on a sketch plan, copies of which are filed in the Mining Titles Office, Johannesburg, and in the Office of the Mining Commissioner, O.F.S., Welkom, under RMT No. R21/84, from the application of the provisions of Chapter X and section 139 (1) of the said Act, with effect from the date of publication hereof in the *Gazette*.

(19/13/1/346)

DEPARTEMENT OF NATIONAL EDUCATION

No. 1117

8 June 1984

WAR GRAVES AND NATIONAL MONUMENTS ACT, No. 28 OF 1969

DECLARATION OF THE PROPERTY INCLUSIVE OF THE KAFFRARIAN MUSEUM COMPLEX THEREON, CONSISTING OF THE OLD MUSEUM BUILDING AND THE DAINES BUILDING (OLD PUBLIC LIBRARY), SITUATED ON THE CORNER OF ALEXANDRA AND ALBERT ROADS, KING WILLIAM'S TOWN

By virtue of the powers vested in me by section 10 (1) of the War Graves and National Monuments Act, 1969 (Act 28 of 1969), I, Gerrit van Niekerk Viljoen, Minister of National Education, hereby declare the property inclusive of the Kaffrarian Museum Complex thereon consisting of the Old Museum Building and the Daines Building (Old Public Library), situated on the corner of Alexandra and Albert Roads, King William's Town, to be a national monument.

Description

The property inclusive of the Kaffrarian Museum Complex, thereon consisting of the Old Museum Building and the Daines Building, situated on certain piece of partly freehold land and partly land, being Erf 3363, King William's Town, in the Municipality of the Borough of King William's Town, in the Division of King William's Town, in extent two thousand nine hundred and forty-six (2 946) square metres.

Certificate of Consolidated Title 102/1972, dated 24 January 1972.

Historical and architectural interest

The Kaffrarian Museum originated from the Natural History Society, which was founded in King William's Town in 1884. The original museum building, which was designed by the architect P. E. Treeby of Johannesburg and opened by Mrs James Weir on 5 October 1898, was extended in 1953 and linked to the Daines Building in 1974. This building, originally erected as a public library thanks to the efforts of Thomas Daines, a pharmacist at Grey Hospital, was designed by the architect S. Stent and opened on 23 July 1877.

These two late-Victorian buildings, which have been combined to form the Kaffrarian Museum Complex, reflect Classical and Neo-Gothic elements. The museum itself is also well-known for its magnificent mammal collection, the largest of its kind in South Africa. 10/2/1111.

G. VAN N. VILJOEN, Minister of National Education.

DEPARTEMENT VAN NYWERHEIDS- WESE EN HANDEL

No. 1135

8 Junie 1984

WET OP STANDAARDE, 1982

VERPLIGTE SPESIFIKASIE: VEILIGHEIDSHELMS VIR MOTORFIETSRYERS

Op aanbeveling van die Raad van die Suid-Afrikaanse Buro vir Standaarde en kragtens die bevoegdheid my verleen by artikel 16 (1) van die Wet op Standaarde, 1982 (Wet 30 van 1982), verklaar ek, Abraham Adriaan Venter, Adjunk-minister van Nywerheidswese, Handel en Toerisme, handelende namens die Minister van Nywerheidswese, Handel en Toerisme, hierby die spesifikasie in die Bylae vervat tot verpligte spesifikasie vir veiligheidshelms vir motorfietsryers, met gelyktydige terugtrekking van die geldende verpligte spesifikasie vir dié kommoditeit soos vervat in die Bylae by Goewermentskennisgewing R. 1545 van 1 September 1972.

Die verpligte spesifikasie tree in werking met ingang van die datum drie maande na publikasie hiervan.

A. A. VENTER, Adjunk-minister van Nywerheidswese, Handel en Toerisme.

BYLAE

VERPLIGTE SPESIFIKASIE VIR VEILIGHEIDSHELMS VIR MOTORFIETSRYERS

1. BESTEK.

1.1 Hierdie spesifikasie dek die vereistes vir die algemene ontwerp, konstruksie, prestasie, merk, etikettering en toets van veiligheidshelms vir gebruik deur motorfietsryers op paaie.

2. WOORDBEPALING.

2.1 Die volgende woordbepalings geld vir die doel van hierdie spesifikasie:

Basisvlak: Die vlak wat deur die buitenste oopeninge en die onderkant van die oogkaste gaan.

Dop: Die harde, glad afgewerkte materiaal wat die algemene buitevorm van die helm uitmaak.

Geriefsopstoppel: Materiaal wat vir groter dragerief voorsien word.

Gesigskerm: Die deel van die helm wat die onderste deel van die gesig bedek en wat 'n integreerende deel van die helm is of daarvan verwyder kan word.

Helmklap: 'n Deursigtige skerm wat oor die oë strek en wat die boonste deel van die gesig bedek.

Kenband: 'n Band wat onder die draer se ken deurgaang om die helm in posisie te hou.

Kendop: 'n Deel wat ontwerp is om om die punt van die draer se ken te pas.

Nekklappie: 'n Deel wat die agterkant van die draer se nek bedek.

Produksielot: Veiligheidshelms van dieselfde ontwerp en konstruksie, uit dieselfde besendings materiaal vervaardig.

Skermbril: 'n Deursigtige beskermers oor die oë.

Skutstoppel: Materiaal wat tot die absorbering van kinetiese energie tydens 'n slag bydra.

Tuit: 'n Halfstewige verlenging van die dop bokant die oë.

DEPARTMENT OF INDUSTRIES AND COMMERCE

No. 1135

8 June 1984

STANDARDS ACT, 1982

COMPULSORY SPECIFICATION.—SAFETY HELMETS FOR MOTOR CYCLISTS

On the recommendation of the Council of the South African Bureau of Standards and under the powers vested in me by section 16 (1) of the Standards Act, 1982 (Act 30 of 1982), I, Abraham Adriaan Venter, Deputy Minister of Industries, Commerce and Tourism, acting on behalf of the Minister of Industries, Commerce and Tourism, hereby declare the specification contained in the Schedule to be a compulsory specification for safety helmets for motor cyclists, with simultaneous withdrawal of the current compulsory specification for this commodity, as contained in the Schedule to Government Notice R. 1545 of 1 September 1972.

The compulsory specification becomes operative from the date three months after publication of this notice.

A. A. VENTER, Deputy Minister of Industries, Commerce and Tourism.

SCHEDULE

COMPULSORY SPECIFICATION FOR SAFETY HELMETS FOR MOTOR CYCLISTS

1. SCOPE.

1.1 This specification covers requirements for the general design, construction, performance, marking, and labelling, and testing of safety helmets for use by motor cyclists on the roads.

2. DEFINITIONS.

2.1 For the purpose of this specification the following definitions shall apply:

Basic plane: The plane that passes through the external ear openings and the lower edge of the eye sockets.

Batch: Safety helmets of the same design and construction, and made from the same consignment of materials.

Chin cup: A device designed to fit around the point of the wearer's chin.

Chin strap: A strap that passes under the wearer's chin to keep the helmet in position.

Comfort padding: Material provided to improve wearing comfort.

Face-cover: That part of the helmet that covers the lower part of the face, and that is integral with, or detachable from, the helmet.

Goggles: Transparent protectors that enclose the eyes.

Neck curtain: A device that covers the back of the wearer's neck.

Peak: A semi-rigid extension of the shell above the eyes.

Protective padding: Material contributing to the absorption of kinetic energy during impact.

Reference plane: A plane at a given distance above and parallel to the basic plane.

Vashoustelsel: Die volledige samestel, met inbegrip van die kenband, waardeur die helm op die kop in posisie gehou word.

Veiligheidshelm: 'n Hoofbedekking wat hoofsaaklik bedoel is om die draer te beskerm teen 'n slag op dié deel van sy kop wat bo die basisvlak is.

Verwysingsvlak: 'n Vlak op 'n gegewe afstand bokant en parallel met die basisvlak.

3. MATERIAAL.

3.1 ALGEMEEN: Die materiaal wat by die vervaardiging van helms gebruik word, moet so wees dat veroudering of die gebruiksomstandighede waaraan 'n helm normaalweg onderwerp word, bv. blootstelling aan die son, temperatuurruiterstes en reën, nie 'n nadelige uitwerking op die eienskappe daarvan het nie.

In gevalle waar dit bekend is dat koolwaterstof, skoonmaakvloeistowwe, verf, oordrukprente of ander toevoegings van buite die dopmateriaal nadelig beïnvloed, moet 'n waarskuwing voorsien word [kyk 6.2 (e)].

Die materiaal wat gebruik word vir dele van 'n helm wat aan die vel raak, moet so wees dat sweet of toiletware nie 'n nadelige uitwerking op die eienskappe daarvan het nie. Die fabrikant mag geen materiaal gebruik wat na wete velaandoenings veroorsaak nie.

3.2 METAALKOMPONENTE: Alle metaaldele wat in 'n helm gebruik word, moet intrinsiek korrosiebestand wees of moet so bedek wees dat die helm aan die vereistes van 5.5 voldoen.

4. KONSTRUKSIE.

4.1 ALGEMEEN: 'n Helm moet gemaak wees in die vorm van 'n harde buitendop wat skutstoppel en geriefstopstoppel bevat. Die helm kan 'n tuit hê, mits dit verwyder kan word en nie 'n integreernde deel van die helm is nie. 'n Helm kan van 'n nekklappie voorsien wees.

4.2 DOP.

(a) Die buiteoppervlak moet glad afgewerk wees en mag nie versterkriwwe hê nie.

(b) Die fatsoen bo die verwysingsvlak moet in die vorm van 'n deurlopende konvekse kurwe wees. Daar kan sigbare afwykings van hierdie kurwe wees, mits alle afwykings binne 'n hoek van hoogstens 150° is en met saamsmelt-radiusse van minstens 4 mm afgeglad is.

(c) Inkepinge vir 'n helmklap en vir helmklap- en vashoustelselhegstukke moet met buitesaamsmelt-radiusse van minstens 2 mm afgeglad wees of moet ingeslote hoeke van minstens 150° tussen aanliggende oppervlakke hê.

(d) Onreëlmatighede in die kurwe onder die verwysingsvlak moet so egalig afgeglad wees dat die radius van enige kurwe, uitgesonderd dié van 'n inkeping vir randafwerking, minstens 4 mm is.

(e) Die dop kan 'n integreernde gesigskerm bevat.

(f) Waar geen middele vir die vashegting van 'n helmklap voorsien word nie, mag die profiel by die voorrand nie verhoed dat 'n skermbril gedra word nie.

(g) Indien daar bokant vlak AA₁ (kyk Fig. 1) gaatjies in die dop is vir enige doel behalwe vashegting van die vashoustelsel of dele daarvan, moet die getal en grootte van die gaatjies so wees dat die totale oppervlakte daarvan hoogstens 150 mm² aan elke kant van die helm beslaan.

Retention system: The complete assembly, including chin strap, by means of which the helmet is maintained in position on the head.

Safety helmet: Headwear primarily intended to protect the wearer from a blow on that part of the wearer's head that lies above the basic plane.

Shell: The hard, smoothly finished material that provides the general outer form of the helmet.

Visor: A transparent protective screen that extends over the eyes and covers the upper part of the face.

3. MATERIALS.

3.1 GENERAL: The materials used in the manufacture of helmets shall be such that their properties are not appreciably affected by aging, or by the circumstances of use to which a helmet is normally subjected, such as exposure to the sun, extremes of temperature, and rain.

Where hydrocarbons, cleaning fluids, paints, transfers, or other extraneous additions are known to affect the shell material adversely a warning shall be provided [see 6.2 (e)].

The materials used for those parts of a helmet that come into contact with the skin, shall be such that their properties are not appreciably affected by sweat or toiletries. The manufacturer shall not use any material known to cause skin disorders.

3.2 METAL COMPONENTS: All metal parts used in a helmet shall be intrinsically corrosion resistant or shall have been so coated as to enable the helmet to comply with the requirements of 5.5

4. CONSTRUCTION.

4.1 GENERAL: The construction of a helmet shall be in the form of a hard outer shell containing the protective and comfort padding. The helmet may incorporate a peak provided that it is detachable and is not an integral part of the helmet. A helmet may be fitted with a neck curtain.

4.2 SHELL.

(a) The outer surface shall be smoothly finished and shall not have reinforcing ridges.

(b) Above the reference plane the shape shall be in the form of a continuous convex curve. There may be visible variations of this curve, provided that any variation is within an angle of not more than 150° and is faired with blend radii of at least 4 mm.

(c) Recesses for a visor and its attachments and retention system attachments shall be faired with external blend radii of at least 2 mm, or shall have included angles of at least 150° between adjacent surfaces.

(d) Below the reference plane, irregularities in the curve shall be so smoothly faired that the radius of any curve, other than that of a recess for edge trim, is at least 4 mm.

(e) The shell may incorporate an integral face-cover.

(f) Where means for attaching a visor are not provided, the profile at the front edge shall not prevent the wearing of goggles.

(g) If the shell is pierced above plan AA₁ (see Fig. 1) for any purpose other than for the attachment of the retention system or its parts, the number and sizes of the apertures shall be such that their total area does not exceed 150 mm² on either side of the helmet.

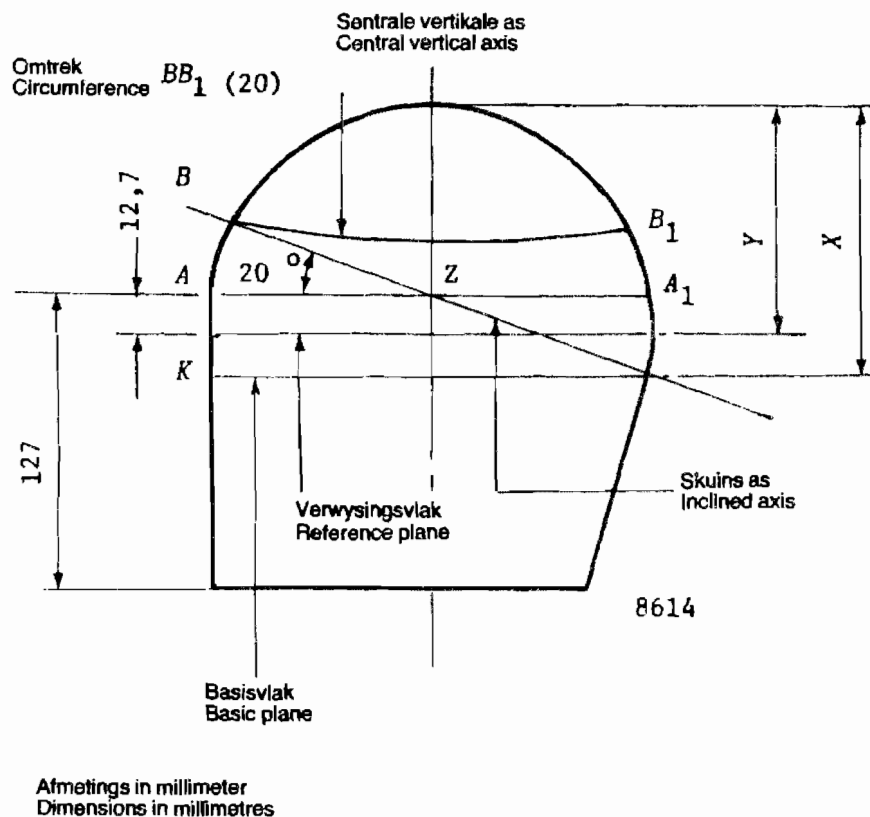

Fig. 1—Tipiese Kopvorm
Fig. 1—Typical Headform

4.3 UITSTEEKSELS.

(a) Daar mag geen uitsteeksels aan die buitekant wees wat verder as 5 mm bo die buiteoppervlak van die dop uitsteek nie, behalwe in die geval van 'n skermbriklapius wat aan die agterkant van die helm voorsien is en wat so ontwerp is dat dit afgehaal kan word.

(b) Enige uitsteeksels aan die buitekant, uitgesonderd drukknope, moet glad en afgeglad wees.

(c) Klinknaelkoppe moet gerond wees en mag hoogstens 2 mm bo die buiteoppervlak van die dop uitsteek.

(d) Daar mag geen skerp rande of onbedekte onbuigsame uitsteeksels aan die binnekant van die helm wees nie.

4.4 HELMKLAPINKEPING: In die geval van 'n helm wat 'n inkeping vir 'n helmklap het, mag die buiteoppervlak van die helmklap in die toe posisie, loodreg op die oppervlak van die helmklap gemeet, hoogstens 3 mm onder die oppervlak van die aanliggende dop wees.

4.5 VASHOUSTESEL.

(a) Die helm moet op die draer se kop in posisie gehou word deur middel van 'n kenband wat aan die dop veranker is. Die vashousteisel kan middele insluit wat groter gemak vir die draer bied.

(b) Die kenband moet, as dit onder 'n trekkrag van 250 N gemeet word, minstens 19 mm breed wees en moet van 'n vaste vasmaakmiddel voorsien wees om die spanning daarvan te verstel en vol te hou.

(c) die kenband mag nie van 'n kendop voorsien wees nie.

4.3 PROJECTIONS.

(a) There shall be no external projections that extend more than 5 mm above the outer surface of the shell, except in the case of a goggle fitting provided at the rear of the helmet and that is designed to be detachable.

(b) Any external projections other than press-fasteners shall be smooth and faired.

(c) Rivet heads shall be radiused and shall not project more than 2 mm above the outer surface of the shell.

(d) There shall be no sharp edges or uncovered rigid projections on the inside of the helmet.

4.4 VISOR RECESS: In a helmet that has a recess to accept a visor, the outer surface of the visor in the closed position shall be not more than 3 mm, measured normal to the surface of the visor, below the surface of the adjacent shell.

4.5 RETENTION SYSTEM.

(a) Retention of the helmet on the wearer's head shall be by means of a chin strap anchored to the shell, and may include means of enhanced comfort for the wearer.

(b) The chin strap shall be at least 19 mm wide, measured when under a tensile force of 250 N, and shall be permanently fitted with a fastening device to adjust and maintain tension.

(c) The chin strap shall not be equipped with a chin cup.

(d) Die knop van die losmaakgespe moet so wees dat die gespe nie oopgaan as dit met 'n bol met 'n diameter van 40 mm getoets word nie.

(e) Die losmaakknop moet rooi wees en geen ander deel van die gespe mag hierdie kleur wees nie.

4.6 PERIFERE UITSIG: By die montering van 'n helm op die kleinste kopvorm wat op die helmgroottereks van toepassing is, moet die helm perifere uitsig bied onder—

(a) 'n hoek van minstens 105°, horisontaal aan weerskante van die oorlangse vlak deur punt K en L (kyk Fig. 2) gemeet; en

(b) 'n hoek van minstens 7° bo die verwysingsvlak en minstens 45° onder die basisvlak van die kopvorm by en tussen twee punte op gelyke afstande van 33 mm aan weerskante van punt K en L.

4.7 OPSIGTELKHEID: Enige fluoresseer- of terugkaatsende materiaal wat deel van die helmdop uitmaak of wat op die buiteoppervlak van die helmdop aangebring is, mag nie voldoening aan enigeen van die vereistes van die spesifikasie verhoed nie.

4.8 SKUTSTOPSEL: Die dop moet gevoer wees met skutstop sel wat so is, of wat so aan die binneoppervlak van die dop aangebring is, dat dit nie tydens gebruik sal los raak nie. Indien die stopsel uit segmente bestaan, mag die breedte van 'n gaping tussen aanliggende segmente nie 6 mm oorskry nie.

4.9 TUIITE: Die tuit (as daar een is) moet buigsaam en so ontwerp wees dat dit nie die draer in die geval van 'n ongeluk sal beseer nie.

(d) The button of the release buckle shall be such that when tested with a 40 mm diameter sphere the buckle does not open.

(e) The release button shall be red and no other part of the buckle shall be of this colour.

4.6 PERIPHERAL VISION: When mounted on the smallest headform appropriate to the size range of the helmet, the helmet shall provide peripheral vision at—

(a) an angle of at least 105°, measured horizontally on each side of the longitudinal plane through the points K and L (see Fig. 2); and

(b) an angle of at least 7° above the reference plane, and at least 45° below the basic plane of the headform at and between two points spaced equally 33 mm on each side of points K and L.

4.7 CONSPICUOUSNESS: Any fluorescent or retro-reflective materials incorporated in the helmet shell or applied to the outer surface of the helmet shell shall not prevent compliance with any of the requirements of the specification.

4.8 PROTECTIVE PADDING: The shell shall be lined with protective padding that is such, or is so attached to the inner surface of the shell, as not to become detached in use. Where the padding is made in segments, the width of a gap between adjacent segments shall not exceed 6 mm.

4.9 PEAKS: The peak (when fitted) shall be flexible and so designed that in the event of an accident it does not cause any injury to the wearer.

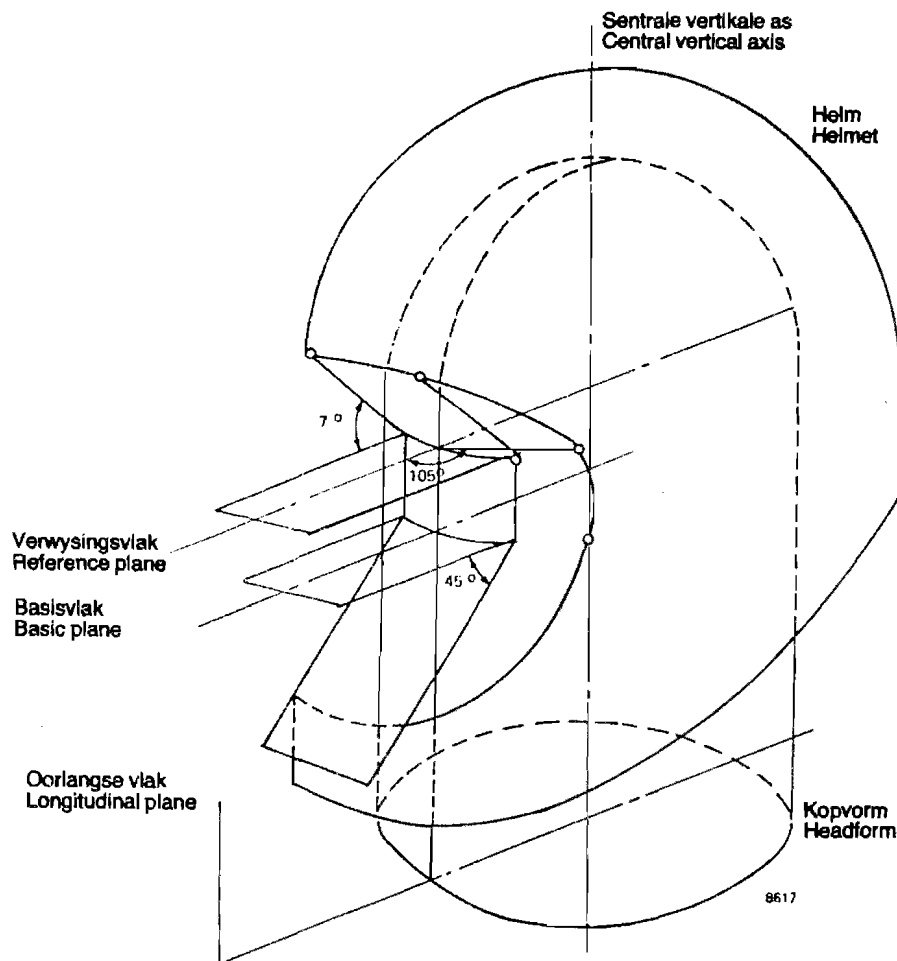

Fig. 2—Perifere Uitsig
Fig. 2—Peripheral Vision

5. PRESTASIEVEREISTES.

5.1 MATE VAN BESKERMING: By die toets van 'n helm volgens 7.3, moet die mate van beskerming wat dit verleen, soos volg wees:

(a) *Dop:* Die dop moet alle dele bo vlak AA₁ bedek en moet aan weerskante van die kopvorm minstens tot by die lyn CDEF (kyk Fig. 3) strek.

(b) *Skutstoppel:* Die skutstoppel moet minstens alle dele bo vlak AA₁ bedek.

5. PERFORMANCE REQUIREMENTS.

5.1 EXTENT OF PROTECTION: When a helmet is tested in accordance with 7.3, the extent of protection provided shall be as follows:

(a) *Shell:* The shell shall cover all areas above plane AA₁ and shall extend downwards at least as far as the lines CDEF (see Fig. 3) on both sides of the headform.

(b) *Protective padding:* The protective padding shall cover at least all areas above plan AA₁.

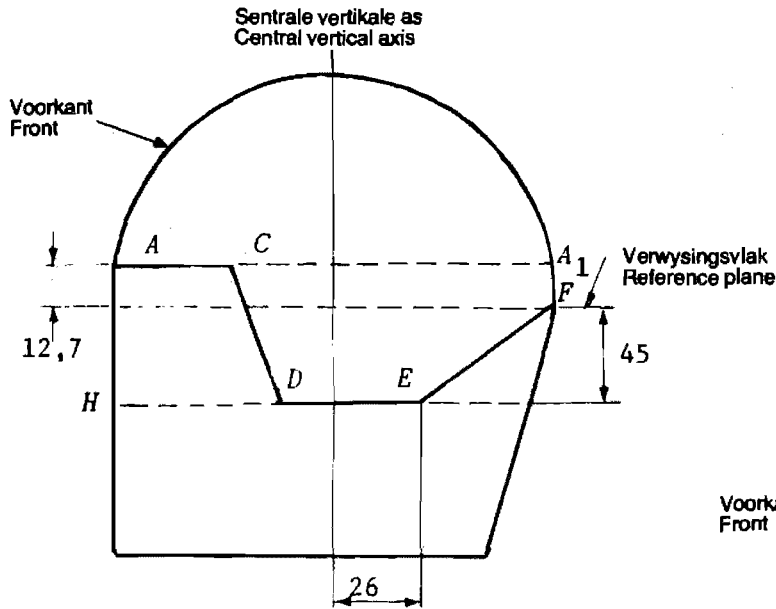

Afmetings in millimeter
Dimensions in millimetres

Kyk Tabel 5 vir afmetings van AC en HD
For dimensions of AC and HD see Table 5

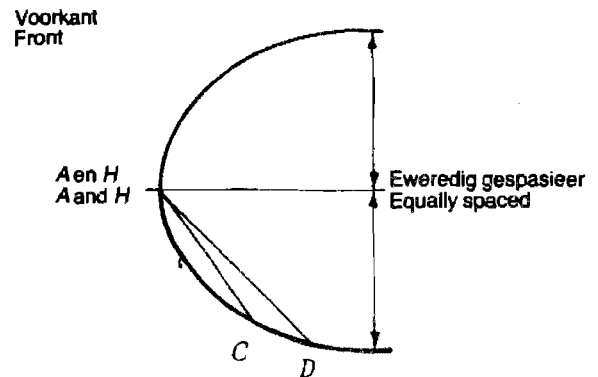

Fig. 3—Mate van Beskerming en Vry Ruimte vir Skermbril
Fig. 3—Extent of Protection and Clearance for Goggles

5.2 DEEL BESKERM TEEN GESPEFISEERDE SLAE EN PENETRASIE: Die skokbreking en penetrasiebestandheid van die deel van 'n helm bo omtreklyn BB₁ (kyk Fig. 1) moet so wees dat die helm aan die volgende vereistes voldoen:

(a) *Skokbreking:* By die toets van 'n helm volgens 7.4, mag die topversnelling wat op die kopvorm oorgedra word, nie 4 000 m/s² oorskry nie.

(b) *Penetrasiebestandheid:* By die toets van 'n helm volgens 7.5, mag die punt van die slagblok nie aan die oppervlak van die kopvorm raak nie.

5.3 STERKTE VAN VASHOUSTELSEL: By die toets van 'n helm volgens 7.6, mag die verlenging van die vashoustelsel, met inbegrip van die mate waarin die gespe gly, nie die waardes in Tabel 1 oorskry nie.

5.2 AREA OF PROTECTION AGAINST SPECIFIED IMPACT AND PENETRATION: The shock absorption and penetration resistance of the area of a helmet above circumference BB₁ (see Fig. 1) shall be such as to enable the helmet to comply with the following requirements:

(a) *Shock absorption:* When a helmet is tested in accordance with 7.4, the peak acceleration imparted to the headform shall not exceed 4 000 m/s².

(b) *Resistance to penetration:* When a helmet is tested in accordance with 7.5, the point of the striker shall not contact the surface of the headform.

5.3 STRENGTH OF RETENTION SYSTEM: When a helmet is tested in accordance with 7.6, the extensions of the retention system, including any slippage of the buckle, shall not exceed the values given in Table 1.

TABEL 1

MAKSIMUM VERLENGING VAN VASHOUSTELSEL

1	2	3
Slag	Dinamiese verlenging mm, maks.	Residuele verlenging, mm, maks.
Eerste	32	16
Tweede	25	8

TABLE 1

MAXIMUM EXTENSION OF RETENTION SYSTEM

1	2	3
Impact	Dynamic extension, mm, max.	Residual extension, mm, max.
First	32	16
Second	25	8

5.4 STEWIGHEID: By die toets van 'n helm volgens 7.7, mag die maksimum vervorming nie die aanvanklike vervorming met meer as 40 mm oorskry nie en mag die permanente residuele vervorming nie 15 mm oorskry nie.

5.5 KORROSIEBESTANDHEID: By die toets van 'n helm volgens 7.8, mag bedekte metaaldele geen teken van indringing tot die basismetale toon nie en mag intrinsiek korrosiebestande metaaldele geen teken van korrosie toon wanneer dit met die blote oog ondersoek word nie.

5.6 TUIE: By die toets van 'n helm volgens 7.9, mag die tuit nie breek nie; dit moet of afval of 'n afwaartse defleksie van minstens 6 mm en hoogstens 32 mm hê.

5.7 STERKTE VAN HELMKLAP: By die toets van 'n helm volgens 7.10, mag die helmklap nie versplinter, skerp hoeke of rande toon of van die helm loskom nie.

6. MERKE EN ETIKETTERING.

6.1 MERKE OP HELM.

6.1.1 Die volgende besonderhede moet leesbaar en onuitwisbaar op die helm aangebring wees op 'n plek waar dit teen uitwissing beskerm is:

- (a) Die fabrikant se naam of handelsmerk of handelsnaam;
- (b) die produksielotidentifikasie;
- (c) die datum van vervaardiging.

6.1.2 Die volgende besonderhede moet op die helm aangebring wees:

- (a) Die grootte of groottereeks;
- (b) die massa van die helm.

6.2 ETIKET SAAM MET HELM VERSKAF: Elke helm moet 'n etiket hê waarop die besonderhede in (a)–(d) en, indien toepaslike, (e) hieronder in albei amptelike tale aangebring is:

- (a) Vir voldoende beskerming moet die helm styf pas.
- (b) Die kenband moet te alle tye reg vasgemaak en styfgetrek word. 'n Kendop moet nie aan die kenband aangebring word nie.
- (c) Die helm is gemaak om, by wyse van gedeeltelike vernietiging van die samestellende dele, van die energie van 'n slag te absorbeer. Hoewel beskadiging nie altyd maklik sigbaar is nie, behoort enige helm wat aan 'n harde slag onderwerp is, vervang te word.
- (d) Om die volle doeltreffendheid van die helm te behou, moet geen verandering aan die struktuur van die helm of die komponente daarvan aangebring word nie.
- (e) Die helm moet nie geverf word of met oplosmiddels skoongemaak word nie.

7. ONDERSOEK EN TOETSMETODES.

7.1 ONDERSOEK: Ondersoek en meet die helm vir voldoening aan al die toepaslike vereistes van die spesifikasie waarvoor toetse vir die beoordeling van voldoening nie in 7.3 tot en met 7.10 voorgeskryf is nie.

7.2 KONDISIONERING.

7.2.1 *Voorkondisionering*: Stel die helm minstens ses uur lank aan 'n temperatuur van 24 ± 2 °C en 'n relatiewe humiditeit van 45 ± 5 % bloot.

5.4 RIGIDITY: When a helmet is tested in accordance with 7.7, the maximum deformation shall not exceed the initial deformation by more than 40 mm, and the residual permanent deformation shall not exceed 15 mm.

5.5 CORROSION RESISTANCE: When a helmet is tested in accordance with 7.8, coated metal parts shall not show any sign of penetration to the basis metal and intrinsically corrosion-resistant metal parts shall not show any sign of corrosion when examined with the unaided eye.

5.6 PEAKS: When a helmet is tested in accordance with 7.9, the peak shall not break; it shall either fall off or have a downward deflection of not less than 6 mm and not more than 32 mm.

5.7 STRENGTH OF VISOR: When a helmet is tested in accordance with 7.10, the visor shall not shatter, display any sharp corners or edges, or become detached from the helmet.

6. MARKING AND LABELLING.

6.1 MARKINGS ON HELMET.

6.1.1 The helmet shall be legibly and indelibly marked with the following information in a position where the marking is protected from obliteration:

- (a) The manufacturer's name or trade mark or trade name;
- (b) the batch identification;
- (c) the date of manufacture.

6.1.2 The helmet shall be marked with the following information:

- (a) The size or range of sizes;
- (b) the mass of the helmet.

6.2 LABEL SUPPLIED WITH HELMET: Every helmet shall have a label bearing, in both official languages, the information given in (a)–(d) and, when relevant, (e) below:

- (a) For adequate protection the helmet must fit closely.
- (b) The chin strap must be fastened correctly and under tension at all times. A chin cup must not be fitted to the chin strap.
- (c) The helmet is made to absorb some of the energy of a blow by partial destruction of its component parts and, even though damage may not be readily apparent, any helmet subjected to a severe impact should be replaced.
- (d) To maintain the full efficiency of the helmet there must be no alteration to the structure of the helmet or its component parts.
- (e) The helmet should not be painted, and solvents must not be used to clean it.

7. INSPECTION AND METHODS OF TEST.

7.1 INSPECTION: Inspect and measure the helmet for compliance with all the relevant requirements of the specification for which tests to assess compliance are not given in 7.3–7.10 (inclusive).

7.2 CONDITIONING.

7.2.1 *Pre-conditioning*: Expose the helmet to a temperature of 24 ± 2 °C and a relative humidity of 45 ± 5 % for at least six hours.

7.2.2 Hoë temperatuur:

(a) *Apparaat:* 'n Oond met 'n waaier vir lugsirkulasie en 'n binnevolum van minstens 0,15 m³ en nie minder as 0,06 m³ per helm nie, wat termostaties beheer word om 'n temperatuur van 50 ± 2 °C te handhaaf.

(b) *Prosedure:* Plaas die helm in die oond en maak seker dat dit nie aan die sye, bokant of onderkant van die oond raak nie. Stel die helm minstens vier uur en hoogstens vyf uur lank aan die temperatuur van 50 ± 2 °C bloot.

7.2.3 Lae temperatuur:

(a) *Apparaat:* 'n Redelik lugdigte koelkas met 'n binnevolum van minstens 0,15 m³ en nie minder as 0,06 m³ per helm nie, wat termostaties beheer word om 'n temperatuur van 0 ± 3 °C te handhaaf.

(b) *Prosedure:* Plaas die helm in die koelkas en stel dit minstens vier uur en hoogstens vyf uur lank aan die temperatuur van 0 ± 3 °C bloot.

7.2.4 Ultravioletstraling en waterindompeling.

(a) Apparaat:

(1) 'n UV-kwartslamp met 'n vermoë van 125 W.

(2) 'n Houer van geskikte grootte, wat water by 'n temperatuur van 24 ± 2 °C bevat.

(b) Prosedure:

(1) Stel die buiteoppervlak van die helm 48 uur lank bloot aan ultravioletstraling afkomstig van die lamp wat op 'n afstand van 250 mm van die helm af geplaas is.

(2) Keer die helm om en dompel dit minstens vier uur en hoogstens vyf uur lank heeltemal onder die water in die houer.

7.3 VERIFIËRING VAN MATE VAN BESKERMING EN PERIFERE UITSIG.

7.3.1 Apparaat: 'n Kopvorm van toepaslike grootte (kyk 8.4).

7.3.2 Prosedure:

(a) Plaas die helm op die kopvorm en maak dit stewig vas. Sorg dat die helmrand bo die gesig parallel gerig is met die basisvlak aan die voor- en sykante van die kopvorm.

(b) Gaan die mate van beskerming van die helm visueel na by die omtrek AA₁ en die lyn CDEF wat op die kopvorm afgemerk is (kyk Fig. 3).

(c) Gaan die mate van perifere uitsig na (kyk 4.6).

(d) Verifieer voldoening aan die vereistes van 4.6, 5.1 (a) en 5.1 (b).

(e) Teken die vertikale afstand tussen die rand van die helm bo die gesig en die basisvlak, voor in die middel van die helm gemeet [kyk 7.4.3 (a)], aan.

7.4 SKOKBREEKTOETS.

7.4.1 (a) Kopvorm: 'n Kopvorm van toepaslike grootte (kyk 8.4).

(b) *Montering:* Die apparaat is op 'n stewige monolitiese basis met 'n massa van minstens 500 kg gemonteer. Die kopvorm is bevestig op 'n tap wat met die sentrale vertikale as van die kopvorm saamval en wat gemonteer is op 'n boog wat om 'n horisontale as draai (kyk Fig. 4). Die posisie van die kopvorm op die boog word verstel na die hoek wat vir die skuins as van die kopvorm vereis word. Rotering van die kopvorm om die tap maak dit moontlik om die slagblok op enige gekose punt op die omtrek van die kopvorm te laat val. 'n Soortgelyke tap wat regstreeks op die stewige basis bevestig is, maak dit moontlik om die kopvorm vertikaal te monteer sodat slae op die bokant van die helm toegedien kan word.

(c) *Slagblok:* Die slagblok het 'n massa van 5^{+0,1}_{-0,0} kg en 'n plat, ronde slaanvlak met 'n diameter van 125 ± 1,0 mm of 'n halfronde slaanvlak met 'n radius 50 ± 0,5 mm en word met minimale vertraging deur die leiers, wat binne 1 op 400 vertikaal is, in 'n geleide baan laat val.

7.2.2 High temperature:

(a) *Apparatus:* An oven having fan-operated air circulation, an internal volume of at least 0,15 m³ and not less than 0,06 m³ per helmet, and thermostatically controlled to maintain a temperature of 50 ± 2 °C.

(b) *Procedure:* Place the helmet in the oven ensuring that it does not touch the sides, top, or bottom of the oven. Expose the helmet to the temperature of 50 ± 2 °C for not less than four hours and not more than five hours.

7.2.3 Low temperature:

(a) *Apparatus:* A reasonably airtight refrigerator having an internal volume of at least 0,15 m³ and not less than 0,06 m³ per helmet, and that is thermostatically controlled to maintain a temperature of 0 ± 3 °C.

(b) *Procedure:* Place the helmet in the refrigerator, and expose the helmet to the temperature of 0 ± 3 °C for not less than four hours and not more than five hours.

7.2.4 Ultraviolet radiation and water immersion:

(a) Apparatus:

(1) A U.V. quartz lamp of power 125 W.

(2) A vessel of adequate size containing water at a temperature of 24 ± 2 °C.

(b) Procedure:

(1) Expose for 48 hours the outer surface of the helmet to ultraviolet radiation from the lamp placed at a distance of 250 mm from the helmet.

(2) Invert the helmet and immerse it totally in the water in the vessel for not less than four hours and not more than five hours.

7.3 VERIFICATION OF EXTENT OF PROTECTION AND PERIPHERAL VISION.

7.3.1 Apparatus: A headform of appropriate size (see 8.4).

7.3.2 Procedure:

(a) Place the helmet on the headform and secure it firmly using the alignment of the edge above the face in relation to the basic plane at the front and sides of the headform to level the helmet.

(b) Check the extent of the protection of the helmet visually against the circumference AA₁ and the lines CDEF marked on the headform (see Fig. 3).

(c) Check the extent of peripheral vision (see 4.6).

(d) Verify compliance with the requirements of 4.6, 5.1 (a), and 5.1 (b).

(e) Note the vertical distance between the edge of the helmet above the face and the basic plane, measured at the front midpoint of the helmet [see 7.4.3 (a)].

7.4 SHOCK ABSORPTION TEST.

7.4.1 (a) Headform: A headform of appropriate size (see 8.4).

(b) *Mounting:* The apparatus is mounted on a rigid monolithic base having a mass of at least 500 kg. The headform is secured to a spigot coincident with its central vertical axis and the spigot is mounted on an arc that pivots about a horizontal axis (see Fig. 4). The position of the headform along the arc is adjusted to the angle required for the inclined axis of the headform. Rotation of the headform about the spigot presents any selected point on the circumference of the headform to the striker. A similar spigot secured directly to the rigid base enables the headform to be mounted vertically for the delivery of blows to the top of the helmet.

(c) *Striker:* The striker has a mass of 5^{+0,1}_{-0,0} kg and a flat circular striking face of diameter 125 ± 1,0 mm or a hemispherical striking face of radius 50 ± 0,5 mm, and is dropped in guided fall with minimal retardation from the guides, which are vertical to within 1 in 400.

(d) *Versnellingsomsetter*: 'n Versnellingsomsetter, wat 'n 20 000-m/s²-skok sonder enige beskadiging kan deurstaan, is stewig op die slagblok aangebring sodat die vertikale as daarvan binne $\pm 2^\circ$ met dié van die slagblok saamval.

(e) *Meetstelsel*: Die meetstelsel, met inbegrip van die slagblok, het 'n plat responsie binne ± 1 dB van 5 Hz tot 3 kHz.

(d) *Acceleration transducer*: An acceleration transducer capable of withstanding a 20 000 m/s² shock without damage is firmly attached to the striker with its vertical axis coincident, to within $\pm 2^\circ$, with that of the striker.

(e) *Measuring system*: The measuring system including the striker has a flat response within ± 1 dB from 5 Hz to 3 kHz.

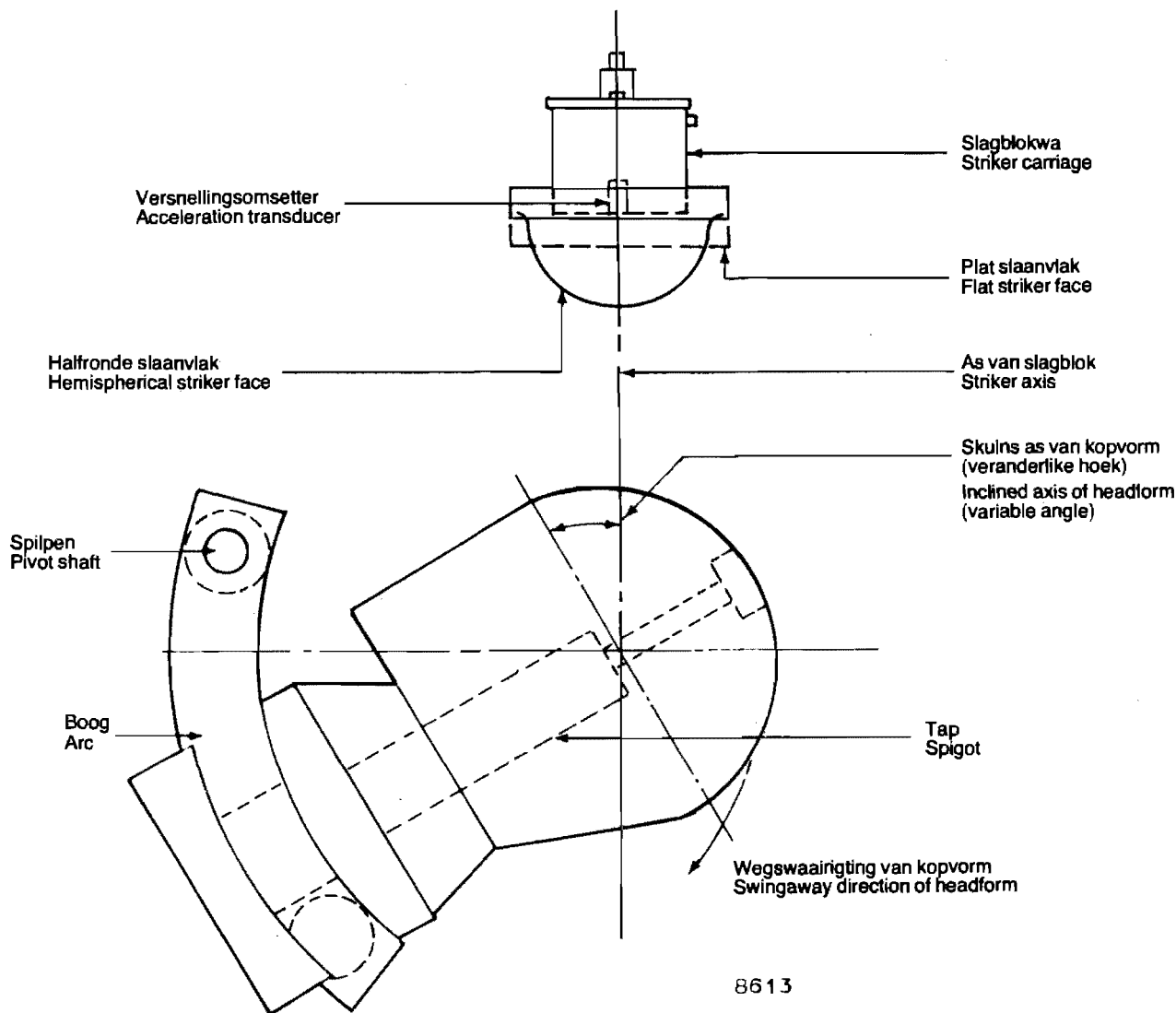

Fig. 4—Skokbreektoetsapparaat
Fig. 4—Shock Absorption Test Apparatus

7.4.2 *Nagaan van instrumente*: Gaan die meetstelsel na, voordat daar met die toetse op die helms begin word, deur die halfronde slagblok vanuit 'n vasgestelde hoogte op 'n geskikte toetsstuk te laat val sodat 'n versnelling van 4 000 m/s² verkry word. Teken minstens drie sodanige slae by elke toetsgeleentheid aan en maak seker dat die resultate binne 'n bestek van 400 m/s² lê.

7.4.3 *Procedure*: Volg enigeen van die toetsprogramme wat in tabel 2 aangegee word en gaan soos volg te werk nadat die helm wat getoets word aan die toepaslike kondisionering onderwerp is:

(a) Maak die helm wat getoets word stewig op die kopvorm vas sodat die vereiste trefpunt van die helm reg onder die slagblok is en die voorrand van die helm op dieselfde afstand van die basisvlak voor in die middel van die kopvorm is, soos voorheen in 7.3.2 (e) gemeet.

7.4.2 *Instrumentation check*: Before commencing helmet tests, check the measuring system by impacting a suitable test piece with the hemispherical striker, dropping the striker from an established height to produce an acceleration of 4 000 m/s². Record at least three such impacts on each occasion of checking and check that the results lie within a range of 400 m/s².

7.4.3 *Procedure*: Use any one of the test schedules given in Table 2 and after subjecting the helmet under test to the appropriate conditioning, proceed as follows:

(a) Securely fasten the helmet to the headform with the required impact site of the helmet presented to the striker, and levelled with the front edge of the helmet set at the same distance from the basic plane at the front midpoint of the headform as previously measured in 7.3.2 (e).

(b) Bepaal die massas van die kopvorm met die helm daarop om die spilpen en in die vertikale as van die slagblok.

(c) Bereken die hoogte waardeur die slagblok laat val moet word om 'n slagenergie van 122 J in die geval van 'n plat slagblok en 88 J in die geval van 'n halfronde slagblok te verkry. Die vereiste slagenergie word verkry deur die slagblok deur 'n hoogte van $\frac{(k + 1)h}{k}$ meter te laat val

waar

$$k = \frac{\text{massa van kopvorm met helm daarop, kg}}{\text{massa van slagblok, kg}}$$

$h = 2,5$ m in die geval van 'n plat slagblok en $1,8$ m in die geval van 'n halfronde slagblok

(d) Lig die slagblok tot die vereiste hoogte, van die onderkant van die slagblok tot by die helmdop gemeet, en maak seker dat dit tot binne 5 mm noukeurig is.

(e) Laat die slagblok op die helm val en teken die versnelling aan.

(f) Herhaal die prosedure in (a)–(e) hierbo nadat die helm, indien nodig, weer reg op die kopvorm geplaas is en maak seker dat die slagblok op dieselfde plek op die helm val.

(g) Toets die helm op drie plekke wat minstens een vyfde van die maksimum omtrek van die helm van mekaar af is.

(h) Maak seker dat slae aan die sykante tussen 0 mm en 25 mm agter die dwarsvlak deur die sentrale vertikale as van die kopvorm toegedien word op lyn BB_1 , d.w.s. die lyn wat verkry word wanneer die hoek tussen die skuins en horisontale vlak van die kopvorm 20° is (kyk Fig. 1).

(i) Maak seker dat slae aan die voor- en agterkant binne 25 mm van die sentrale langsas van die kopvorm en op lyn BB_1 toegedien word.

(j) Verifieer voldoening aan die vereistes van 5.2 (a).

(b) Determine the mass load of the helmeted headform about the pivot shaft and in the vertical axis of the striker.

(c) Calculate the height through which the striker has to be dropped to attain an impact energy of 122 J in the case of the flat striker and 88 J in the case of the hemispherical striker. These impact energies are attained by the striker

falling through a height of $\frac{(k + 1)h}{k}$ metres,

where

$$k = \frac{\text{mass of helmeted headform, kg}}{\text{mass of striker, kg}}$$

$h = 2,5$ m for flat striker and $1,8$ m for hemispherical striker

(d) Raise the striker to the required height, measured from the underside of the striker to the helmet shell, and ensure that it is accurate to within 5 mm.

(e) Drop the striker onto the helmet and record the acceleration.

(f) After any necessary repositioning of the helmet on the headform, and ensuring that the striker drops on the same impact site on the helmet, repeat the procedure given in (a)–(e) above.

(g) Test the helmet on three sites separated by distances of not less than one-fifth of the maximum circumference of the helmet.

(h) Ensure that side impacts are between 0 mm and 25 mm rearwards of the transverse plane through the central vertical axis of the headform, and on line BB_1 , i.e. the line generated when the angle between the inclined and horizontal plane of the headform is 20° (see Fig. 1).

(i) Ensure that front and rear impacts are within 25 mm of the central longitudinal axis of the headform, and on line BB_1 .

(j) Verify compliance with the requirements of 5.2 (a).

TABEL 2
TOETSPROGRAM VIR SKOKBREEKTOETS

1	2	3	4	5	6
Toets-program	Kondisionering (kyk 7.2)	Tipe slaanvlak	Trefpunte	Tydsverloop tussen verwydering uit kondisioneeruitrusting, min	
				Eerste slag	Voltooiing van toets
1	Hoë temperatuur	Halfronde	Voor, agter en sy	1-2	20 maks.
2	Lae temperatuur	Halfronde	Voor, agter en sy	1-2	20 maks.
3	Waterindompeling	Halfronde	Voor, agter en bo	15 maks.*	35 maks.
4	Hoë temperatuur	Plat	Voor, agter en sy	1-2	20 maks.
5	Lae temperatuur	Plat	Voor, agter en sy	1-2	20 maks.
6	Waterindompeling	Plat	Voor, agter en bo	15 maks.*	35 maks.

* Toegelaat vir dreinerings.

TABLE 2
TEST SCHEDULE FOR SHOCK ABSORPTION TEST

1	2	3	4	5	6
Test schedule	Conditioning (See 7.2)	Type of striker face	Impact sites	Time lapse between removal from conditioning, equipment, min	
				First impact	Completion of test
1	High temperature	Hemispherical	Front, rear, and side	1-2	20 max.
2	Low temperature	Hemispherical	Front, rear, and side	1-2	20 max.
3	Water immersion	Hemispherical	Front, rear, and top	15 max.*	35 max.
4	High temperature	Flat	Front, rear, and side	1-2	20 max.
5	Low temperature	Flat	Front, rear, and side	1-2	20 max.
6	Water immersion	Flat	Front, rear, and top	15 max.*	35 max.

* Allowed for drainage.

7.5 PENETRASIETOETS.

7.5.1 *Apparaat*: Die apparaat (kyk Fig. 5) bestaan wesenlik uit die volgende:

(a) 'n *Halfronde toetsblok* van loofhout, wat 'n sagtemetaalinsetsel aan die bokant van die sentrale as het en wat op 'n stewige basis gemonteer is.

(b) 'n *Slagpen* met die volgende kenmerke:

Massa	3,0 kg $^{+45}_{-0}$ g
Hoek van keël	$60^\circ \pm 0,5$
Hoogte van keël	40 mm, min.
Radius van punt	$0,5 \pm 0,1$ mm
Hardheid van spits	45-50 HR

(c) 'n *Metode* waardeur elektries aangedui word wanneer die slagpen aan die sagtemetaalinsetsel raak.

7.5 PENETRATION TEST.

7.5.1 *Apparatus*: The apparatus (see Fig. 5) consists essentially of the following:

(a) A *hemispherical test block* of hardwood and having a soft metal insert at the top of its central axis and mounted on a rigid base.

(b) A *striker* with the following characteristics:

Mass	3,0 kg $^{+45}_{-0}$ g
Angle of cone	$60^\circ \pm 0,5^\circ$
Height of cone	40 mm, min.
Radius of point	$0,5 \pm 0,1$ mm
Hardness of tip	45-50 HR

(c) A *method* of electrically indicating when the striker touches the soft metal insert.

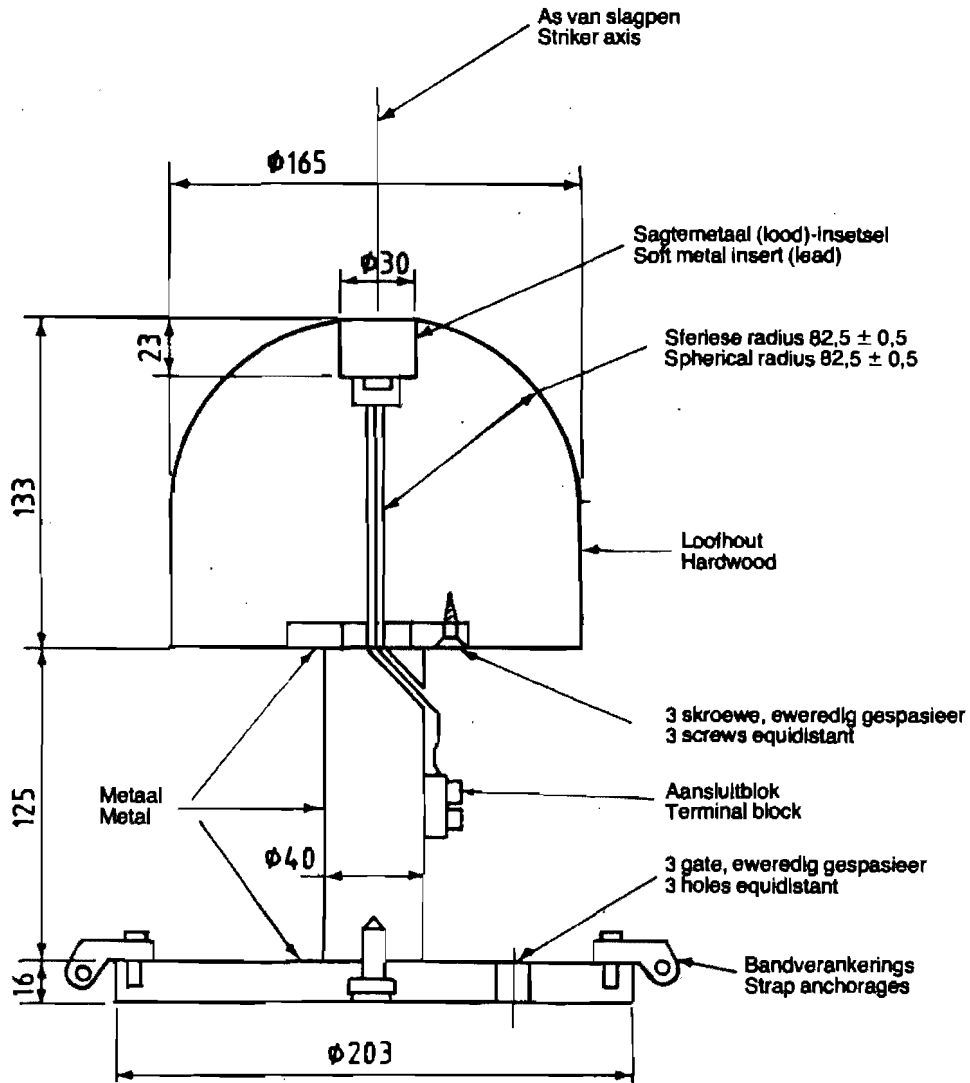

Afmetings in millimeter behoudens 'n toleransie van ± 1 mm
Dimensions in millimetres tolerance ± 1 mm

8619

Fig. 5—Toetsblok vir Penetrasietoets
Fig. 5—Test Block for Penetration Test

7.5.2 Procedure:

(a) Maak die helm stewig op die toetsblok vas.

(b) Laat die slagpen vry vanuit 'n hoogte van $2,5 \text{ mm} \pm 5 \text{ mm}$ (van die punt van die slagpen tot by die beoogde trefpunt op die helm gemeet) op twee plekke wat òf op òf bo die omtrek BB_1 [kyk 7.4.3 (h)] en minstens 45 mm van mekaar en van die middelpunte van die trefplekke van die skokbreektoets af geleë is, op die helm val.

(c) Teken aan of kontrak tussen die slagpen en die sagte-metaalinsetsel gemaak word en herstel die oppervlak van laasgenoemde, indien nodig, voor die volgende toets.

(d) Verifieer voldoening aan die vereistes van 5.2 (b).

7.6 TOETS VIR STERKTE VAN VASHOUSTELSEL.

7.6.1 *Apparaat:* Die apparaat (kyk Fig. 6) bestaan wesenslik uit die volgende:

(a) 'n *Kopvorm* van toepaslike grootte (kyk 8.4).

7.5.2 Procedure:

(a) Fasten the helmet securely to the test block.

(b) Allow the striker to fall freely from a height of $2,5 \text{ mm} \pm 5 \text{ mm}$ (measured from the point of the striker to the anticipated point of impact on the helmet) onto the helmet at two sites on or above the circumference BB_1 [see 7.4.3 (h)] and separated by at least 45 mm from each other and from the centres of the impact sites of the shock absorption test.

(c) Note whether contact is made between the striker and the soft metal insert and, if necessary, restore the surface of the latter, before the next test.

(d) Verify compliance with the requirements of 5.2 (b).

7.6 TEST FOR STRENGTH OF RETENTION SYSTEM.

7.6.1 *Apparatus:* The apparatus (see Fig. 6) consists essentially of the following:

(a) A headform of appropriate size (see 8.4).

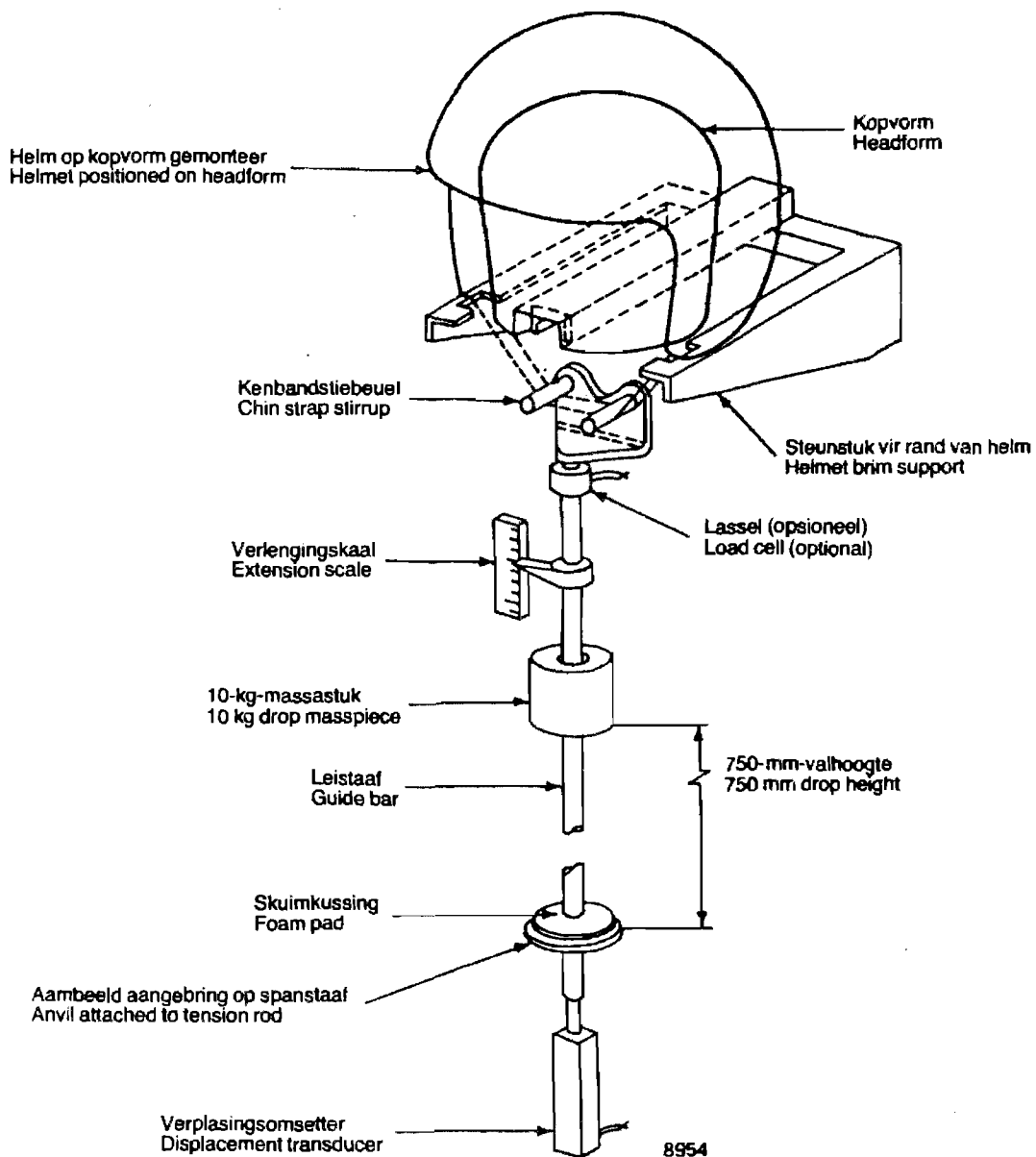

Fig. 6—Toetsapparaat vir Sterkte van Vashousteisel
Fig. 6—Retention System Test Apparatus

(b) 'n Monteerstuk vir die kopvorm wat 'n drasteunstuk vir die rand van die helm bevat.

(c) 'n Stiebeuel met twee metaalrollers wat elk 'n diameter van $12,5 \pm 0,5$ mm het en wat op 'n hartafstand van $75,0 \pm 0,5$ mm gespasieer is.

(d) 'n Leistaaf en aambeeld wat integreerend met die stiebeuel is en wat van die stiebeuel af vertikaal na onder strek, waarop 'n meter vir die meting van die maksimum dinamiese, sowel as die residuele verlenging van die kenband gemonteer is. Die stelsel het 'n totale massa van $7,0_{-0,25}^{+0}$ kg.

(e) 'n Ringvormige massastuk met 'n massa van $10_{-0}^{+0,25}$ kg, wat op die leistaaf gedra word en wat vryelik laat val kan word op die aambeeld wat 'n poliëteenskui mkussing met 'n dikte van 10 mm dra.

7.6.2 Procedure:

(a) Bevestig die helm so oor die kopvorm en op die drasteunstuk dat enige las wat op die vasgemaakte kenband geplaas word, deur die steunstuk gedra word en nie deur die kopvorm wat bloot as 'n gids vir die plasing van die helm dien nie.

(b) Maak die kenband so onder die stiebeuel vas dat die kenband die stiebeuel en die leistaaf-en-aambeeldstelsel steun en dat die stiebeuel 120–140 mm onder die kopvorm is.

(c) Stel die verlengingsmeter op nul.

(d) Laat die 10-kg-massastuk vanuit 'n hoogte van 750 ± 5 mm op die aambeeld val.

(e) Teken die dinamiese verlenging aan en meet die residuele verlenging met die 10-kg-massastuk steeds op die aambeeld.

(f) Stel die verlengingsmeter weer op nul.

(g) Herhaal (d) en (e) hierbo sonder om aan die kenband te raak.

(h) Verifieer voldoening aan die vereistes van 5.3.

7.7. TOETS VIR STEWIGHEID.

7.7.1 Apparaat: Die apparaat bestaan wesenlik uit die volgende:

(a) 'n Geskikte belasmassien wat 'n drukkrag van tot minstens 630 N kan uitoefen en twee geleide parallelle metaalplate het wat elk voorsien is van 'n loofhoutskyfie met 'n diameter van 150 mm, wat 'n gat met 'n diameter van 15 mm in die middel daarvan het.

(b) Middele om die afstand tussen die twee loofhoutskyfies te meet.

7.7.2 Procedure:

(a) Kondisioneer die helm vooraf soos in 7.2.1 en plaas dit so tussen die loofhoutskyfies dat drukknoppe (indien daar is) op die helm in die 15-mm-gate in die middel van die skyfies is.

(b) Wend 'n krag van 30 N deur middel van die plate op die dop aan.

(c) Meet die afstand tussen die skyfies na twee minute en teken dit as die aanvanklike vervorming aan.

(d) Verhoog die krag met inkremente van 100 N in 2-minuut-intervalle tot 630 N.

(e) Meet die afstand tussen die skyfies twee minute nadat die 630-N-krag aangewend is en teken dit as die maksimum vervorming aan.

(f) Verminder die krag na 30 N en hou dit vyf minute lank vol.

(g) Meet die afstand tussen die skyfies en teken dit as die residuele vervorming aan.

(h) Verifieer voldoening aan die vereiste van 5.4.

(b) A mount for the headform that incorporates a load-bearing support for the brim of the helmet.

(c) A stirrup that has two metal rollers, each $12,5 \pm 0,5$ mm in diameter, spaced at $75,0 \pm 0,5$ mm centres.

(d) A guide bar and anvil integral with and extending vertically downwards from the stirrup, and on which is mounted a gauge for measuring both the maximum dynamic and residual extension of the chin strap. The system has a total mass of $7,0_{-0,25}^{+0}$ kg.

(e) An annular masspiece, of mass $10_{-0}^{+0,25}$ kg, that is carried on the guide bar and that can be dropped in free fall onto the anvil, which carries a 10 mm thick pad of polyethylene foam.

7.6.2 Procedure:

(a) So secure the helmet over the headform and onto the load-bearing support that any load placed on the fastened chin strap is borne by the support and not by the headform, which acts only as a positioning guide for the helmet.

(b) So fasten the chin strap under the stirrup that the chin strap supports the stirrup and the guide bar and anvil system, and that the stirrup is 120–140 mm below the headform.

(c) Adjust the extension-measuring gauge to zero.

(d) Drop the 10 kg masspiece from a height of 750 ± 5 mm onto the anvil.

(e) Record the dynamic extension and with the 10 kg mass still on the anvil, measure the residual extension.

(f) Reset the extension-measuring gauge to zero.

(g) Without touching the chin strap, repeat (d) and (e) above.

(h) Verify compliance with the requirements of 5.3.

7.7 TEST FOR RIGIDITY

7.7.1 Apparatus: The apparatus consists essentially of the following:

(a) A loading machine that has two guided parallel metal plates, each fitted with a hardwood disc of diameter 150 mm and having a central hole of diameter 15 mm, and that is capable of applying compressive forces of up to at least 630 N.

(b) Means of measuring the distance between the two hardwood discs.

7.7.2 Procedure:

(a) Pre-condition the helmet as in 7.2.1 and so place it between the hardwood discs that press-fasteners (if any) on the helmet are located in the 15 mm central holes.

(b) Apply a force of 30 N to the shell by means of the plates.

(c) Measure the distance between the discs after 2 min and record it as the initial deformation.

(d) Increase the force to 630 N by increments of 100 N applied at 2 min intervals.

(e) Measure the distance between the discs 2 min after application of the 630 N force and record it as the maximum deformation.

(f) Reduce the force to 30 N and maintain it for 5 minutes.

(g) Measure the distance between the discs and record it as the residual deformation.

(h) Verify compliance with the requirement of 5.4.

7.8 TOETS VIR KORROSIEBESTANDHEID.

7.8.1 *Toetsoplossing:* 'n Oplossing wat vyf dele natriumchloried en 95 dele gedistilleerde water (volgens massa) bevat en wat by 'n temperatuur van $35 \pm 3^\circ\text{C}$ gehou word.

7.8.2 *Prosedure:* Bespuit die hele helm 24 uur lank ononderbroke met die toetsoplossing. Was die helm onder skoon lopende water, laat dit droog word en ondersoek dit vir voldoening aan die vereistes van 5.5.

7.9 TOETS VIR BUIGSAAMHEID VAN TUIT.**7.9.1 Apparaat:**

(a) 'n *Kopvorm* van toepaslike grootte (kyk 8.4).

(b) 'n *Draadhaak* wat uit 'n stuk veerstaaldraad met 'n diameter van 3 mm en 'n massa van $0,1 \text{ kg} \pm 5 \text{ g}$ bestaan, waarvan elke ent gebuig is om 'n haak te vorm, soos in Fig. 7 aangetoon.

(c) 'n *Massastuk* met 'n totale massa van $0,9^{+0,05}_{-0,0}$ kg, waaraan 'n ring bevestig is.

7.9.2 Prosedure:

(a) Kondisioneer die helm wat getoets word, vooraf soos in 7.2.1 en bevestig dit dan oor die kopvorm.

(b) Laat die draadhaak in die middel van die voorrand van die tuit ahang (kyk Fig. 7) en teken die vertikale hoogte van die voorrand van die tuit bo 'n geskikte verwysingslyn aan.

(c) Laat die massastuk twee minute lank aan die ander haak hang.

(d) Meet die vertikale verskuiwing van die voorrand van die tuit.

(e) Verifieer voldoening aan die vereistes van 5.6.

7.8 CORROSION RESISTANCE TEST.

7.8.1 *Test solution:* A solution containing five parts of sodium chloride and 95 parts of distilled water (by mass) and maintained at a temperature of $35 \pm 3^\circ\text{C}$.

7.8.2 *Procedure:* Spray the entire helmet continuously for a period of 24 h with the test solution. Wash the helmet under clean running water, dry, and examine for compliance with the requirements of 5.5.

7.9 TEST FOR FLEXIBILITY OF PEAK.**7.9.1 Apparatus:**

(a) A *headform* of appropriate size (see 8.4).

(b) A *hooked wire* consisting of a length of spring steel wire, of diameter 3 mm and mass $0,1 \text{ kg} \pm 5 \text{ g}$, and having each end bent to form a hook shaped as in Fig. 7.

(c) A *masspiece* having a ring attached to it and of total mass $0,9^{+0,05}_{-0,0}$ kg.

7.9.2 Procedure:

(a) Pre-condition the helmet under test as in 7.2.1, and then secure it over the headform.

(b) Suspend the hooked wire centrally from the front edge of the peak (see Fig. 7), and record the vertical height of the front edge of the peak above a suitable reference level.

(c) Hang the masspiece on the other hook for 2 minutes.

(d) Measure the vertical displacement of the front edge of the peak.

(e) Verify compliance with the requirements of 5.6.

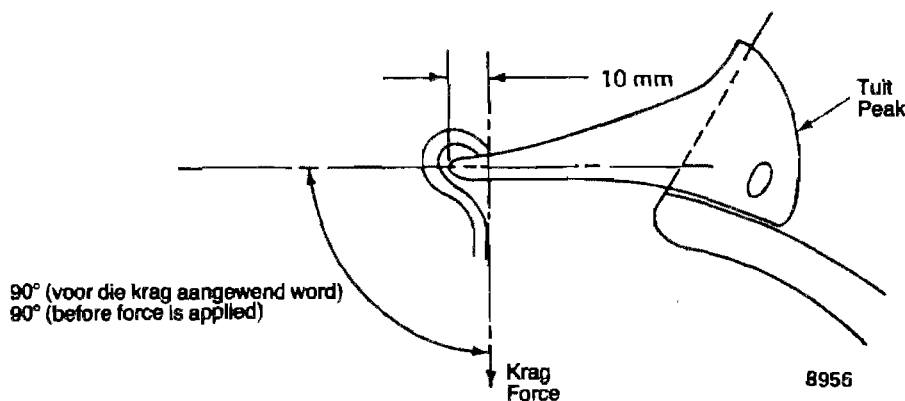

Fig. 7—Toets vir Buigsaamheid van Tuit
Fig. 7—Test for Flexibility of Peak

7.10 TOETS VIR STERKTE VAN HELMKLAP.

7.10.1 *Apparaat:* Die apparaat (kyk Fig. 8) bestaan wesenlik uit die volgende:

(a) 'n *Kopvorm* van toepaslike grootte (kyk 8.4), wat so horisontaal onder 'n leibus gemonteer is dat die slagpen in die middel van die helmklap sal val.

(b) 'n *Vryvallende slagpen*, soos in 7.5.1 (b).

7.10.2 Prosedure:

(a) Monteer die volledige helm en helmklap, wat soos in 7.3.2 gekondisioneer is, op die kopvorm sodat die helmklap na die vallende slagpen wys (kyk Fig. 8) en maak seker dat die slagpen die middel van die helmklap sal tref.

(b) Laat die slagpen met 'n energie van 30 J op die helmklap val.

7.10 TEST FOR STRENGTH OF VISOR.

7.10.1 *Apparatus:* The apparatus (see Fig. 8) consists essentially of the following:

(a) A *headform* of appropriate size (see 8.4) so mounted horizontally below a guide tube that the striker will fall on the centre of the visor.

(b) A *free-falling striker* as in 7.5.1 (b).

7.10.2 Procedure:

(a) Mount the complete helmet and visor, conditioned as in 7.2.2, on the headform with the visor facing the falling striker (see Fig. 8) and ensure that the striker will hit the centre of the visor.

(b) Release the striker to fall on the visor with an energy of 30 J.

(c) Onderzoek en verifieer voldoening aan die vereistes van 5.7.

(d) Herhaal (a)-(c) hierbo, maar gebruik 'n volledige helm en helmklap wat soos in 7.3.3 gekondisioneer is.

(c) Inspect and verify compliance with the requirements of 5.7.

(d) Repeat (a)-(c) above but use a complete helmet and visor conditioned as in 7.2.3.

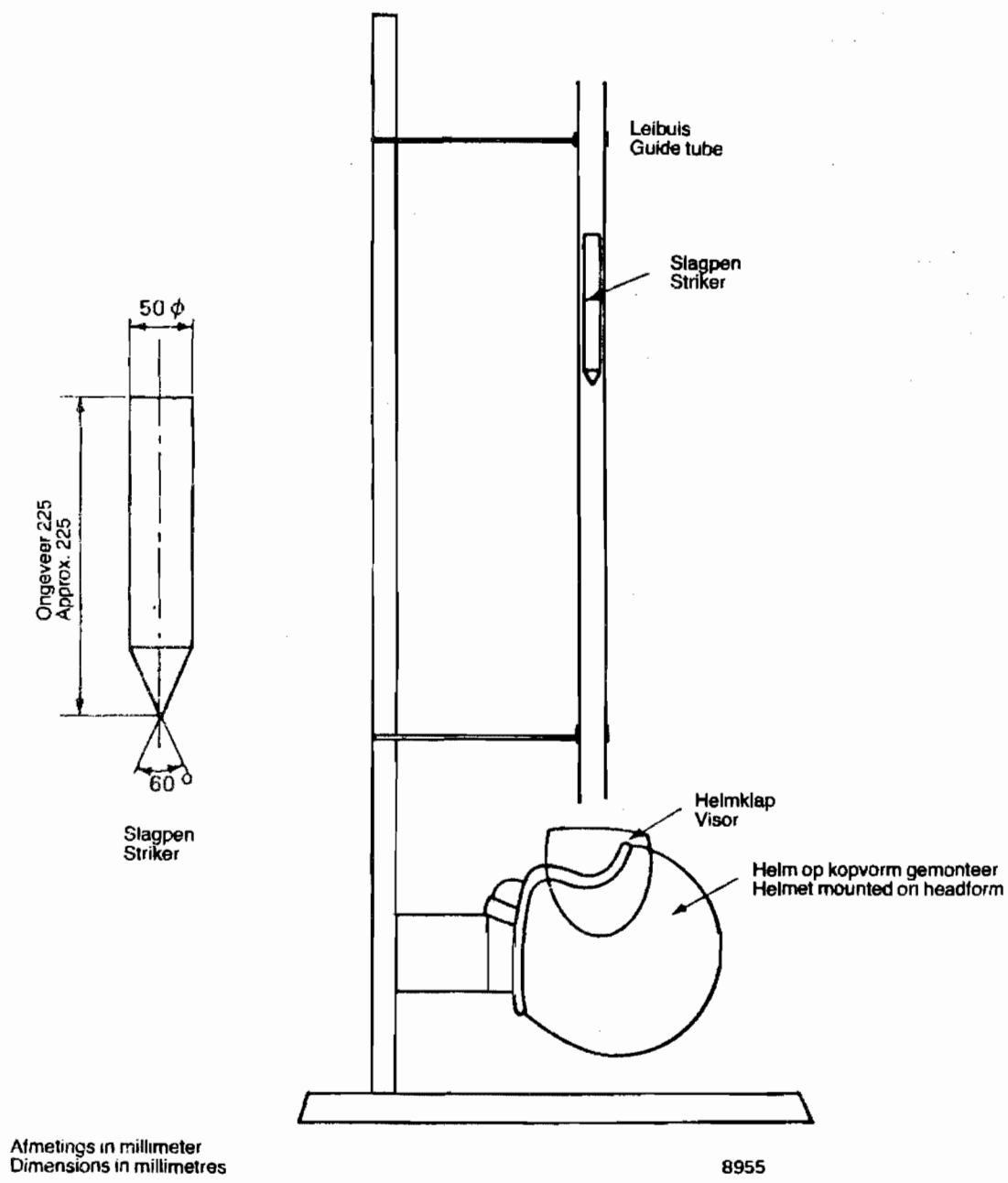

Fig. 8—Toetsapparaat vir Sterkte van Helmklap
Fig. 8—Test Apparatus for Visor Strength

8. KOPVORMS.

8.1 ALGEMEEN: Slegs dié deel van 'n kopvorm bo die basisvlak is ontwerp om die menslike kop voor te stel. Die verskeidenheid menslike kopvorms is van so 'n aard dat 'n kunsmatige kopvorm nie noodwendig presies met die vorm van 'n willekeurige voorbeeld van 'n menslike kop sal ooreenstem nie. Die ses kopvorms wat beskryf word, word as geskik beskou om beskermende helms wat noukeurig pas vir bykans 95 % van die bevolking vir alle bevolkings-groepe, te voorsien.

8. HEADFORMS.

8.1 GENERAL: Only that part of a headform above the basic plane is designed to represent the human head. The variation of human head shapes is such that an artificial headform may not necessarily conform exactly to the shape of any random sample human head; the six headforms described are considered suitable to provide accurately fitting protective helmets for approximately 95 % of the population of all races.

8.2 KONSTRUKSIE: Die kopvorms word gemaak van loofhout wat 'n digtheid binne die bestek van 640–720 kg/m³ en 'n voggehalte van 12 % het. Die lae word bo die verwysingsvlak geskaaf tot diktes wat met die verwysingshoogtes ooreenstem en die draad word van laag tot laag met 90° verplaas. Na finale fatsoenering word die toepaslike lyne (kyk 8.3) op die kopvorms afgemerk en word die kopvorms met verskeie lae vernis geseël.

8.3 MERKE: Die volgende word op elke kopvorm afgemerk:

- (a) Die basisvlak (kyk Fig. 9);
- (b) die langs- en dwarsvlak deur die vertikale as; en
- (c) die lyne ACDEF aan weerskante (kyk Fig. 3).

8.4 AFMETINGS EN BASIESE DATA: Die volgende is op alle kopvorms van toepassing:

- (a) Die afmetings is soos in Tabelle 3, 4, 5 en 6 aangegee.
- (b) Die omtrekafmetings in kolom 2 van Tabel 3 aangegee, geld vir die binneomtrek van die helms, gemeet by die kopbandvlak (of AA₁) (kyk Fig. 1) om die toepaslike kopvormgroottes aan te dui.

8.2 CONSTRUCTION: The headforms are made from a hardwood that has a density in the range 640–720 kg/m³ at a moisture content of 12 %. Above the reference plane, the layers are planed to thicknesses to match the datum levels, the grain being displaced by 90° from layer to layer. After final shaping, the headforms are marked with the appropriate lines (see 8.3) and sealed with several coats of varnish.

8.3 MARKING: The following are marked on each headform:

- (a) The basic plane (see Fig. 9);
- (b) the longitudinal and transverse planes through the vertical axis; and
- (c) the lines ACDEF on both sides (see Fig. 3).

8.4 DIMENSIONS AND BASIC DATA: The following applies to all headforms:

- (a) The dimensions are as given in Tables 3, 4, 5 and 6.
- (b) The circumferences given in column 2 of Table 3 apply to the internal circumferences of the helmets measured at the headband level (or AA₁) (see Fig. 1) to indicate the appropriate headform sizes.

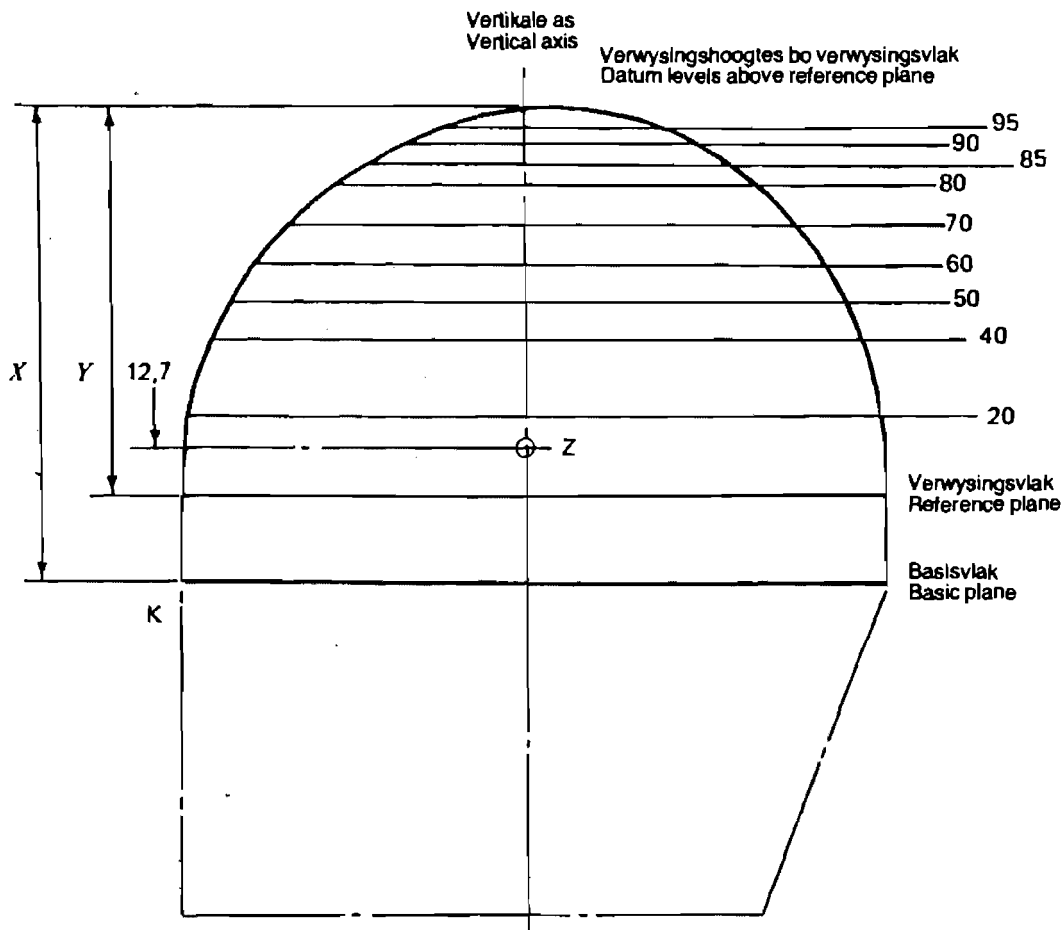

Afmetings in millimeter
Dimensions in millimetres

Kyk Tabel 4 vir afmetings van X en Y
For dimensions of X and Y see Table 4

Kyk Tabel 6 vir poolkoördinate van horisontale halfdeursnee
For polar co-ordinates of horizontal half-sections see Table 6

Fig. 9—Kopvorm: Basiese Data
Fig. 9—Headform: Basic Data

(c) Tabel 6 gee die poolkoördinate van horisontale halfdeursneë by elke verwysingshoogte aan. Koördinate vir hoogte 0 geld ook vir die basisvlak.

(d) Kopvorms is simmetries om die oorlangse vlak deur die vertikale as.

(e) Verwysingshoogtes is in millimeter bo die verwysingsvlak.

(f) Die profiel onder die basisvlak is na keuse, d.w.s. ontwerp om by die toetsmetode te pas.

(g) Punt Z (kyk Fig. 9) op die sentrale vertikale as, 12,7 mm bo die verwysingsvlak, word as die swaartepunt van die menslike kop beskou.

(c) Table 6 gives the polar co-ordinates of horizontal half-sections at each datum level. Co-ordinates for Level 0 also apply to the basic plane.

(d) Headforms are symmetrical about the longitudinal plane through the vertical axis.

(e) Datum levels are in millimetres above the reference plane.

(f) The profile below the basic plane is optional, i.e. designed to suit the method of test.

(g) Point Z (see Fig. 9) on the central vertical, 12,7 mm above the reference plane, is taken as the centre of gravity of the human head.

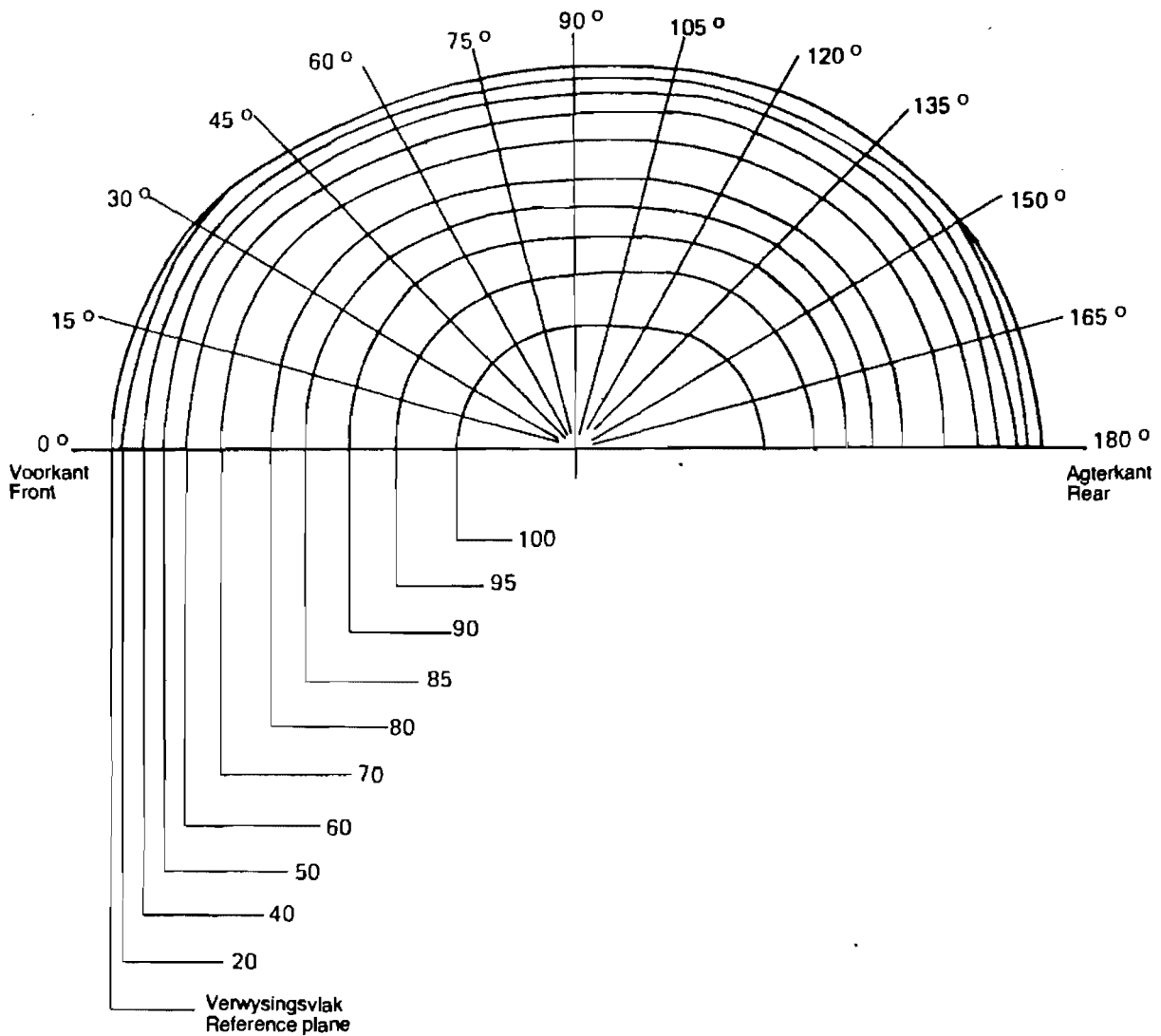

Afmetings in millimeter
Dimensions in millimetres

8615

Kyk Tabel 6 vir poolkoördinate van horisontale halfdeursneë
For polar co-ordinates of horizontal half-sections see Table 6

Fig. 10—Horisontale Halfdeursneë by Verwysingshoogte
Fig. 10—Horizontal Half-Sections at Datum Level

TABEL 3
KOPVORMGROOTTES

1	2
Kodeletter van kopvorm	Binneomtrek van helms, mm
C	520
E	540
G	560
K	580
M	600
O	620

TABEL 4
AFMETINGS X EN Y
(Kyk Fig. 9)

1	2	3
Kodeletter van kopvorm	Afmeting X, mm	Afmeting Y, mm
C	118	93,0
E	122	96,0
G	126	99,0
K	132	104,0
M	136	107,0
O	140	110,2

TABEL 5
AFMETINGS VAN AC EN HD*
(Kyk Fig. 3)

1	2	3
Kodeletter van kopvorm	Afmeting AC†, mm	Afmeting HD†, mm
C	82	98
E	84	101
G	86	103
K	89	105
M	90	107
O	92	110

* 'n Toleransie van 0,25 mm geld vir alle afmetings.
† Die lengtes van die koorde wat met behulp van verdeelpassers gemeet is.

TABLE 3
HEADFORM SIZES

1	2
Code letter of headform	Inside circumference of helmets, mm
C	520
E	540
G	560
K	580
M	600
O	620

TABLE 4
DIMENSIONS X AND Y
(See Fig. 9)

1	2	3
Code letter of headform	Dimension X, mm	Dimension Y, mm
C	118	93,0
E	122	96,0
G	126	99,0
K	132	104,0
M	136	107,0
O	140	110,2

TABLE 5
DIMENSIONS OF AC AND HD*
(See Fig. 3)

1	2	3
Code letter of headform	Dimension AC†, mm	Dimension HD†, mm
C	82	98
E	84	101
G	86	103
K	89	105
M	90	107
O	92	110

* All dimensions are subject to a tolerance of 0,25 mm.
† The lengths of the cords measured with the aid of dividers.

TABEL 6
POOLKOOORDINATE VAN HORIZONTALA HALFDURSNEË
(Kyk Fig. 10)

1	2	3	4	5	6	7	8	9	10	11	12	13	14	15
Kodeletter van kopvorm	Verwysings-hoogte, mm	Radiaallyn, grade												
		0 Voor-kant	15	30	45	60	75	90	105	120	135	150	165	180 Agter-kant
C	0	91,5	89,5	86,0	79,0	72,5	70,0	69,5	72,5	77	82	87,5	90,5	91,5
	20	90,0	88,0	85,5	79,0	72,5	70,0	69,5	72,5	77	82	87	90	90,5
	40	84,5	83,0	82,0	76,0	70,0	68,0	68,0	70,5	74,5	79,5	83,5	85,5	86,5
	50	79,5	78,5	77,5	72,5	67,0	64,5	64,5	67	71	76	79,5	81	81,5
	60	72,5	72,0	71,0	67,0	62,0	59,5	59,5	62	66	71	74	75	75
	70	62,0	62,0	61,5	58,0	54,0	52,0	52,0	54,5	58,5	63	66	66,5	66,5
	80	46,0	46,0	45,5	43,5	42,0	40,5	41,0	43	46,5	51	54,5	55	55
	85	35,5	35,5	35,0	33,5	32,5	32,0	32,5	34,5	38	42	44,5	45,5	45,5
	90	20,0	20,0	19,5	19,0	18,5	18,5	19,5	21	24	28	30	40,5	30,5

1	2	3	4	5	6	7	8	9	10	11	12	13	14	15
Kodeletter van kopvorm	Verwysings-hoogte, mm	Radiaallyn, grade												
		0 Voor-kant	15	30	45	60	75	90	105	120	135	150	165	180 Agter-kant
E	0	94,5	93	90	82	76,5	73,5	73	76	80	85	91	94	94,5
	20	92,5	91,5	89	82	76,5	73,5	73	76	80	85	90,5	93,5	94
	40	87	87,5	85	79,5	74,5	71	71,5	74	77,5	82,5	88	89	89
	50	82,5	83	81	76	71	68	68	70,5	74	79,5	83,5	84,5	84,5
	60	76,5	76,5	75,5	71	66,5	63,5	63,5	66	69,5	74	78,5	79	79
	70	66,5	66,5	66,5	63	59	56,5	56,5	58,5	62	66,5	70,5	71	71
	80	52	52	52	50	47,5	46	46,5	48	51	56	59,5	60	60
	85	41,5	41,5	41,5	40,5	39,5	39	39,5	41	44	48	51,5	52	52
	90	28	28	28,5	28,5	28,5	29	30	31	34	37,5	41,5	42	42
	95	10	10	10	10	10	10,5	11	12	13,5	15	16	16	16
G	0	97,5	95,5	93	85,5	79,5	76	76	78,5	83	88,5	94	97	97,5
	20	95,5	94	92	85,5	79,5	76	76	78,5	83	88,5	94	96,5	97
	40	90	89	88	83	77	74,5	74	76,5	81	86	91	92	92
	50	86,5	86	85	79,5	74	71,5	71,5	73,5	78,5	83,5	87,5	88,5	88,5
	60	80,5	80	79,5	74	70	66,5	66	68,5	73	78	82	82	82,5
	70	71	71	71	67	62,5	60	59,5	61,5	66,5	71,5	74,5	75	75
	80	57,5	57,5	57,5	55	52	50	50	53	57	62	65	65	65
	85	48	48	48	47	45	44	44	46	50	55,5	59	59	59
	90	37	37	37	36	36,5	36	36	38	42	48	50	51	51
	95	21	21	21	22	23	24	24	26	29	34	38	39,5	39,5
K	0	102,5	101	97	90	84	81,5	81	83,5	88	93	98,5	101,5	102,5
	20	100,5	99	97	90	84	81,5	81	83,5	88	93	98,5	101	102
	40	95	95,5	93	87	82	79	79	81,5	85	90	95	97	97,5
	50	91,5	91	90	84,5	79	76,5	76,5	79	83	88	92,5	93	93,5
	60	86	86	85	79,5	74,5	72	72,5	75	78,5	83	86,5	88	88,5
	70	77,5	77,5	77,5	73	68,5	66	66	68,5	72	77	80	81,5	81,5
	80	67	67	67	65,5	60,5	58	57	59,5	63	68	72	72,5	72,5
	85	59,5	59,5	59,5	58	55	53	52	54	57	62,5	66	66,5	66,5
	90	50	50	50	50	47	45,5	45,5	47,5	50,5	50,5	60	60	60
	95	39	39	39	39	38	36,5	37,5	39	43	48	52	52,5	52,5
100	25	25	25	25,5	26	26	25	26,5	30	35	39	41	41	
M	0	106	104	101	93,5	87	84,5	84	86,5	91	96	102	106	106
	20	103,5	102,5	99,5	93	87	84,5	84	86,5	91	96	101,5	105,5	105,5
	40	99	98,5	96,5	90,5	85	82,5	82	84	88,5	93,5	98	100,5	100,5
	50	95,5	94,5	93	87,5	82	79,5	79	81,5	85,5	90	96	97	97
	60	89,5	88	83	77,5	75	75	77	81,5	86,5	86,5	91	92	92
	70	82	82	81	77	72	69,5	69,5	71,5	75,5	81	84	85,5	85,5
	80	71,5	71,5	71	68	64	61,5	61,5	64	67	72	76	77	77
	85	64,5	64,5	64	61,5	59	57	57	58,5	61,5	66,5	71	72	72
	90	56,5	56,5	56,5	55	53	51,5	51,5	53	56	60,5	64,5	66	66
	95	46,5	46,5	47	46,5	45,5	44	44	45,5	48,5	53	57,5	59	58,5
100	32	32	32,5	33	34	34	34,5	35,5	38,5	43	46,5	48,5	48	
105	12	12	13	14	15	16	17,5	19,5	21	25	28,5	30	30	
O	0	108,5	107,5	103,5	96	90,5	87,5	87	90	94,5	100	105	108	108,5
	20	106,5	105,5	103	96	90,5	87,5	87	90	94,5	100	105	108	107,5
	40	101,5	101,5	100,5	93,5	88,5	85,5	85,5	88,5	92,5	98	103	103	103,5
	50	98	97,5	97	90,5	85,5	82,5	83	85,5	90	95	100	100	100,5
	60	93	93	92	86	81	78,5	79,5	81,5	80,5	90,5	95	95	95
	70	86,5	86,5	86	80,5	76	73,5	73,5	76	80	85	89	89	89
	80	76	76,5	76,5	72,5	68	66	66,5	69	72,5	77	81	80,5	80,5
	85	69,5	69,5	70	67,5	62,5	61,5	62	64,5	67,5	72,5	76	76	76
	90	62,5	62,5	62,5	60	57	55,5	56,5	58,5	62	67	70	70	70,5
	95	54	54	54	52,5	50	49	49,5	51,5	55,5	60,5	64	63,5	64
100	42	41,5	41,5	41	41	41,5	41,5	43,5	47	52	55,5	55,5	54,5	
105	27,5	27	26,5	27	27,5	28	27,5	29	31,5	36	37,5	38	37,5	

TABLE 6
POLAR CO-ORDINATES OF HORIZONTAL HALF-SECTIONS
(See Fig. 10)

1	2	3	4	5	6	7	8	9	10	11	12	13	14	15
Code letter headform	Datum level, mm	Radial line, degrees												
		0 Front	15	30	45	60	75	90	105	120	135	150	165	180 Rear
C	0	91,5	89,5	86,0	79,0	72,5	70,0	69,5	72,5	77	82	87,5	90,5	91,5
	20	90,0	88,0	85,5	79,0	72,5	70,0	69,5	72,5	77	82	87	90	90,5
	40	84,5	83,0	82,0	76,0	70,0	68,0	68,0	70,5	74,5	79,5	83,5	85,5	86,5
	50	79,5	78,5	77,5	72,5	67,0	64,5	64,5	67	71	76	79,5	81	81,5
	60	72,5	72,0	71,0	67,0	62,0	59,5	59,5	62	66	71	74	75	75
	70	62,0	62,0	61,5	58,0	54,0	52,0	52,0	54,5	58,5	63	66	66,5	66,5
	80	46,0	46,0	45,5	43,5	42,0	40,5	41,0	43	46,5	51	54,5	55	55
	85	35,5	35,5	35,0	33,5	32,5	32,0	32,5	34,5	38	42	44,5	45,5	45,5
	90	20,0	20,0	19,5	19,0	18,5	18,5	19,5	21	24	28	30	40,5	30,5
E	0	94,5	93	90	82	76,5	73,5	73	76	80	85	91	94	94,5
	20	92,5	91,5	89	82	76,5	73,5	73	76	80	85	90,5	93,5	94
	40	87	87,5	85	79,5	74,5	71	71,5	74	77,5	82,5	88	89	89
	50	82,5	83	81	76	71	68	68	70,5	74	79,5	83,5	84,5	84,5
	60	76,5	76,5	75,5	71	66,5	63,5	63,5	66	69,5	74	78,5	79	79
	70	66,5	66,5	66,5	63	59	56,5	56,5	58,5	62	66,5	70,5	71	71
	80	52	52	52	50	47,5	46	46,5	48	51	56	59,5	60	60
	85	41,5	41,5	41,5	40,5	39,5	39	39,5	41	44	48	51,5	52	52
	90	28	28	28,5	28,5	28,5	29	30	31	34	37,5	41,5	42	42
95	10	10	10	10	10	10,5	11	12	13,5	15	16	16	16	
G	0	97,5	95,5	93	85,5	79,5	76	76	78,5	83	88,5	94	97	97,5
	20	95,5	94	92	85,5	79,5	76	76	78,5	83	88,5	94	96,5	97
	40	90	89	88	83	77	74,5	74	76,5	81	86	91	92	92
	50	86,5	86	85	79,5	74	71,5	71,5	73,5	78,5	83,5	87,5	88,5	88,5
	60	80,5	80	79,5	74	70	66,5	66	68,5	73	78	82	82	82,5
	70	71	71	71	67	62,5	60	59,5	61,5	66,5	71,5	74,5	75	75
	80	57,5	57,5	57,5	55	52	50	50	53	57	62	65	65	65
	85	48	48	48	47	45	44	44	46	50	55,5	59	59	59
	90	37	37	37	36	36,5	36	36	38	42	48	50	51	51
95	21	21	21	22	23	24	24	26	29	34	38	39,5	39,5	
K	0	102,5	101	97	90	84	81,5	81	83,5	88	93	98,5	101,5	102,5
	20	100,5	99	97	90	84	81,5	81	83,5	88	93	98,5	101	102
	40	95	95,5	93	87	82	79	79	81,5	85	90	95	97	97,5
	50	91,5	91	90	84,5	79	76,5	76,5	79	83	88	92,5	93	93,5
	60	86	86	85	79,5	74,5	72	72,5	75	78,5	83	86,5	88	88,5
	70	77,5	77,5	77,5	73	68,5	66	66	68,5	72	77	80	81,5	81,5
	80	67	67	67	65,5	60,5	58	57	59,5	63	68	72	72,5	72,5
	85	59,5	59,5	59,5	58	55	53	52	54	57	62,5	66	66,5	66,5
	90	50	50	50	50	47	45,5	45,5	47,5	50,5	50,5	60	60	60
95	39	39	39	39	38	36,5	37,5	39	43	48	52	52,5	52,5	
100	25	25	25	25,5	26	26	25	26,5	30	35	39	41	41	
M	0	106	104	101	93,5	87	84,5	84	86,5	91	96	102	106	106
	20	103,5	102,5	99,5	93	87	84,5	84	86,5	91	96	101,5	105,5	105,5
	40	99	98,5	96,5	90,5	85	82,5	82	84	88,5	93,5	98	100,5	100,5
	50	95,5	94,5	93	87,5	82	79,5	79	81,5	85,5	90	96	97	97
	60	89,5	88	83	77,5	75	75	77	81,5	86,5	86,5	91	92	92
	70	82	82	81	77	72	69,5	69,5	71,5	75,5	81	84	85,5	85,5
	80	71,5	71,5	71	68	64	61,5	61,5	64	67	72	76	77	77
	85	64,5	64,5	64	61,5	59	57	57	58,5	61,5	66,5	71	72	72
	90	56,5	56,5	56,5	55	53	51,5	51,5	53	56	60,5	64,5	66	66
95	46,5	46,5	47	46,5	45,5	44	44	45,5	48,5	53	57,5	59	58,5	
100	32	32	32,5	33	34	34	34	34,5	35,5	38,5	43	46,5	48,5	
105	12	12	13	14	15	16	17,5	19,5	21	25	28,5	30	30	
O	0	108,5	107,5	103,5	96	90,5	87,5	87	90	94,5	100	105	108	108,5
	20	106,5	105,5	103	96	90,5	87,5	87	90	94,5	100	105	108	107,5
	40	101,5	101,5	100,5	93,5	88,5	85,5	85,5	88,5	92,5	98	103	103	103,5
	50	98	97,5	97	90,5	85,5	82,5	83	85,5	90	95	100	100	100,5
	60	93	93	92	86	81	78,5	79,5	81,5	80,5	90,5	95	95	95
	70	86,5	86,5	86	80,5	76	73,5	73,5	76	80	85	89	89	89
	80	76	76,5	76,5	72,5	68	66	66,5	69	72,5	77	81	80,5	80,5
	85	69,5	69,5	70	67,5	62,5	61,5	62	64,5	67,5	72,5	76	76	76
	90	62,5	62,5	62,5	60	57	55,5	56,5	58,5	62	67	70	70	70,5
95	54	54	54	52,5	50	49	49,5	51,5	55,5	60,5	64	63,5	64	
100	42	41,5	41,5	41	41	41,5	41,5	43,5	47	52	55,5	55,5	54,5	
105	27,5	27	26,5	27	27,5	28	27,5	29	31,5	36	37,5	38	37,5	

No. 1134 **8 Junie 1984**
KANGWANE REGERINGSDIENS
KANGWANE GOEWERMENSKENNISGEWING
1 VAN 1984

KANGWANE-WET OP DIE REGERINGSDIENS, 1979
(WET 3 VAN 1979)

VOORGESKREWE APPARAAT

Kragtens die bevoegdheid my verleen by artikel 1 (1) van die KaNgwane Wet op die Regeringsdiens, 1979 (Wet 3 van 1979), bepaal ek, Nganani Enos Mabuza, Uitvoerende Raadslid vir Owerheidsake, dat die voorgeskrewe apparaat deur middel waarvan die asem van 'n persoon getoets word om te bepaal of die alkoholinhoud van die bloed van die bedoelde persoon die perk soos voorgeskryf in artikel 18 (k) (ii) van genoemde Wet oorskry, die "Alcolyser" apparaat sal wees vanaf die datum van die verskyning van hierdie kennisgewing in die *Staatskoerant*.

N. E. MABUZA, Uitvoerende Raadslid vir Owerheidsake.

No. 1142 **8 Junie 1984**
AANSTELLING VAN PLAASVERVANGENDE LEDE
VAN DIE DORPERAAD, NATAL

Hierby word vir algemene inligting bekendgemaak dat dit die Minister van Samewerking en Ontwikkeling behaag het om, kragtens die bevoegdheid hom verleen by regulasie 3 (1) (b) van die Regulasies vir die Administrasie van en Beheer oor Sekere Gebiede in Natal, te wete—

- (1) Hlabisa-dorp en -dorpsgrond in die distrik Hlabisa;
- (2) Ingwavuma-dorp en -dorpsgrond in die distrik Ingwavuma;
- (3) Nkandla-dorp en -dorpsgrond in die distrik Nkandla;
- (4) Nqutu-dorp en -dorpsgrond in die distrik Nqutu;
- (5) Somkele-dorp en -dorpsgrond in die distrik Hlabisa, aan alle kante begrens deur Reservaat 3, county Zoeloeland;
- (6) Ubombo-dorp en -dorpsgrond in die distrik Ubombo;
- (7) Pomeroy-dorp en -dorpsgrond in die distrik Msinga;
- (8) Mahlabatini-dorp en -dorpsgronde in die distrik Mahlabatini en geleë binne die grense van die gebied beskryf as "The Townlands of Mahlabatini 14638" op 'n plan in die Kantoor van die Landmeter-generaal van Natal;
- (9) Umbumbulu, synde die gebied omskryf as "Onderverdeling B van Umlazi-Naturellelokasie No. 4676" op Diagram 2416/1937 van die Landmetergeneraal van Natal;

vervat in Bylae B van Proklamasie 67 van 1983, ondergenoemde persone, met ingang van die datum van publikasie van hierdie kennisgewing tot 30 Junie 1986, as plaasvervangende lede vir lede van die Dorperaad, ingestel by Goewermentskennisgewing 1341 van 24 Junie 1983, aan te stel:

Raadslid	Plaasvervangende lid
Johannes Jacobus van der Watt.	Johannes Hermanus Hansmeyer.
Paul Stefanus Jacobus Labuschagne.	Thomas Edgar Strachan.
Hindle Barry Isherwood.	John Melville Evatt.
Walter Frank Neville Wiggell.	Stanley Edwin Armstrong.

P. G. J. KOORNHOF, Minister van Samewerking en Ontwikkeling.

(Lêer H1/2/2/1)

No. 1134 **8 June 1984**
KANGWANE GOVERNMENT NOTICE
KANGWANE GOVERNMENT NOTICE 1 OF 1984
KANGWANE PUBLIC SERVICE ACT, 1979
(ACT 3 OF 1979)

PRESCRIBED APPARATUS

Under and by virtue of the powers vested in me by section 1 (1) of the KaNgwane Public Service Act, 1979 (Act 3 of 1979), I, Nganani Enos Mabuza, Executive Councillor for Authority Affairs, hereby determine that the prescribed apparatus by means of which the breath of any person is tested in order to determine whether or not the alcohol content of the blood of such person exceeds the limit as prescribed in section 18 (k) (ii) of the said Act, shall be the "Alcolyser" apparatus with effect from the date of publication of this notice in the *Government Gazette*.

N. E. MABUZA, Executive Councillor for Authority Affairs.

No. 1142 **8 June 1984**
APPOINTMENT OF ALTERNATE MEMBERS OF THE
TOWNSHIPS BOARD, NATAL

It is hereby notified for general information that the Minister of Co-operation and Development has, under and by virtue of the powers vested in him by regulation 3 (1) (b) of the Regulations for the Administration and Control of Certain Areas in Natal, to wit—

- (1) Hlabisa Town and Townlands in the District of Hlabisa;
- (2) Ingwavuma Town and Townlands in the District of Ingwavuma;
- (3) Nkandla Town and Townlands in the District of Nkandla;
- (4) Nqutu Town and Townlands in the District of Nqutu;
- (5) Somkele Town and Townlands in the District of Hlabisa and bordered on all sides by Reserve 3, County of Zululand;
- (6) Ubombo Town and Townlands in the District of Ubombo;
- (7) Pomeroy Town and Townlands in the District of Msinga;
- (8) Mahlabatini Town and Townlands in the District of Mahlabatini and situate within the boundaries of the area described as "The Townlands of Mahlabatini 14638" on a plan in the office of the Surveyor-General of Natal;
- (9) Umbumbulu, being the area described as "Subdivision B of Umlazi Native Location No. 4676" on a diagram, numbered 2416/1937, of the Surveyor-General of Natal;

contained in Schedule B of Proclamation 67 of 1983, been pleased to appoint the undermentioned persons, with effect from the date of publication of this notice to 30 June 1986, as alternate members of the Townships Board, established by Government Notice 1341 of 24 June 1983:

Member	Alternate member
Johannes Jacobus van der Watt.	Johannes Hermanus Hansmeyer.
Paul Stefanus Jacobus Labuschagne.	Thomas Edgar Strachan.
Hindle Barry Isherwood.	John Melville Evatt.
Walter Frank Neville Wiggell.	Stanley Edwin Armstrong.

P. G. J. KOORNHOF, Minister of Co-operation and Development.

(File H1/2/2/1)

STAATKUNDIGE ONTWIKKELING EN BEPLANNING • CONSTITUTIONAL DEVELOPMENT AND PLANNING

No. 1156

8 Junie/June 1984

STAAT VAN INVORDERINGS VAN PROVINSIALE INKOMSTE (INSLUITEND DIREKTE INVORDERINGS DEUR PROVINSIES) VAN 1 APRIL 1983 TOT 31 MAART 1984
STATEMENT OF PROVINCIAL REVENUE COLLECTIONS (INCLUDING COLLECTIONS DIRECT BY PROVINCES) FROM 1 APRIL 1983 TO 31 MARCH 1984

Hoofde van Inkomste Head of Revenue	Kaap die Goeie Hoop Cape of Good Hope		Natal		Transvaal		Oranje-Vrystaat Orange Free State		Totale Totals	
	1/3/84- 31/3/84	1/4/83- 31/3/84	1/3/84- 31/3/84	1/4/83- 31/3/84	1/3/84- 31/3/84	1/4/83- 31/3/84	1/3/84- 31/3/84	1/4/83- 31/3/84	1/3/84- 31/3/84	1/4/83- 31/3/84
<i>Bronne van Inkomste oorgedra/ Sources of Revenue transferred</i>	R	R	R	R	R	R	R	R	R	R
Lisensies/Licences Hond, vis en wild/Dog, fish and game	11 726	201 194	129 218	518 068	80 400	795 396	120 860	724 334	342 204	2 238 992
Motorvoertuie/Motor vehicles ..	20 448 597	79 588 644	4 350 486	46 812 628	26 680 740	175 394 771	5 131 112	20 771 290	56 610 935	322 567 333
Diverse/Miscellaneous Onderwysontvangste/Education receipts	1 235 443	18 806 037	187 893	4 085 980	5 417 253	21 652 679	265 090	5 968 625	7 105 679	50 513 321
Hospitaalontvangste / Hospital receipts	3 411 837	40 614 936	1 410 370	15 520 040	1 008 153	55 492 365	1 273 999	15 662 512	7 104 359	127 289 853
Ander ontvangste/Other receipts	752 071	15 544 678	7 278 224	44 442 736	1 648 290	32 036 472	754 045	6 858 535	10 432 630	98 882 421
Boetes en verbeurdverklarings/ Fines and forfeitures	460	33 830	264 901	2 875 494	2 879 988	18 719 568	331 848	3 312 741	3 477 197	24 941 633
Venduregte/Auction dues	—	—	40 047	460 951	—	—	36 291	451 830	76 338	912 781
Belasting op vermaaklikhede/ Entertainment tax	—	—	—	—	—	—	1 822	21 262	1 822	21 262
Belasting op wedrenne en weddenskappe/Racing and betting taxation	1 696 426	17 076 353	807 834	8 038 826	4 039 361	46 814 542	488 150	5 189 802	7 031 771	77 119 523
Wielbelasting en bydraes/Wheel tax	—	—	3	29	—	—	6 739	38 849	6 742	38 878
Swart hospitaalbelasting en by- draes/Black hospital tax and contributions	—	—	—	—	—	—	196	11 515	196	11 515
Totale/Totals..... R	27 556 560	171 865 672	14 468 976	122 754 752	41 754 185	350 905 793	8 410 152	59 011 295	92 189 873	704 537 512
Totale/Totals (1982-83) R	19 417 761	132 498 776	8 880 097	92 450 967	46 606 099	300 047 524	6 582 261	49 233 836	81 486 218	574 231 103

J. E. DU PLESSIS,

Direkteur-generaal: Departement van Staatkundige Ontwikkeling en Beplanning.
Director-General: Department of Constitutional Development and Planning.

ALGEMENE KENNISGEWINGS

KENNISGEWING 352 VAN 1984

TITUSRIVIER - BESPROEINGSRAAD, AFDELING CERES, KAAPPROVINSIE.—TOEWYSING VAN WERKSAAMHEDE, BEVOEGDHEDE EN PLIGTE

Kragtens die bevoegdheid my verleen by Goewermementskennisgewing 2669 van 18 Desember 1981, wys ek, Johan Ernst Friedrich Winter, in my hoedanigheid van Assistent-direkteur in die Departement van Omgewingsake, hierby die werksaamhede, bevoegdhede en pligte omskryf in artikel 89 (1) (a), (b), (c), (d), (e), (f) en (g) van die Waterwet, 1956 (Wet 54 van 1956), aan die Ixopo-besproeiingsraad toe.

J. E. F. WINTER, Assistent-direkteur: Departement van Omgewingsake.

(8 Junie 1984)

KENNISGEWING 353 VAN 1984

DEPARTEMENT VAN POS- EN TELEKOMMUNIKASIEWESE

Ek, Henry Odendal Bester, Posmeester-generaal, bepaal hierby kragtens artikel 2B (1) (e) van die Poswet, 1958 (Wet 44 van 1958), en met die goedkeuring van die Minister van Pos- en Telekommunikasiewese, die gelde, tariewe en koste wat ten opsigte van die betrokke telekommunikasiedienste geëis of ontvang moet word, soos in die Bylae uiteengesit is.

H. O. BESTER, Posmeester-generaal.

BYLAE

1.0 In hierdie Bylae beteken die uitdrukking "die Tarieflys" die Tarieflys vir Telekommunikasiedienste afgekondig by Goewermementskennisgewing 1192 van 1 Julie 1977, soos gewysig.

2.0 Item 1.0 van die Tarieflys word hierby deur die byvoeging van die volgende gewysig:

	Installeer- en ander koste	Maandelikse huur, tensy anders vermeld
<p>1.4 Gratis huur en installering: T.o.v. een hooftelefoondiens vir woningdoeleindes vir 'n Poskantoor-pensioen-trekker (alle volksgroepe), die weduwee van sodanige pensioen-trekker asook die weduwee van 'n afgestorwe Poskantooramptenaar wat tydens sy dienstermyn in die toewyng van 'n halfamptelike telefoondiens gedeel of daarvoor gekwalifiseer het of volgens geldende voorskrifte daarvoor sou kon kwalifiseer as sodanige toewyng nog nie tydens sy dienstermyn bestaan het nie: Met dien verstande dat sodanige weduwees bevredigende bewys aan die Posmeester-generaal lewer dat hul nie weer getroud is nie: en voorts met dien verstande dat die toewyng verval sodra hul weer in die huwelik tree</p> <p>1.4.1 Enige bevoordeling kragtens item 1.4 geld slegs vanaf die telefoonrekening wat volg op die datum waarop die begunstigde skriftelik aansoek by die Posmeester-generaal gedoen het: Met dien verstande dat die Posmeester-generaal 'n krediet op 'n vorige rekening mag toestaan."</p>	<p>GEEN</p>	<p>GEEN</p>

GENERAL NOTICES

NOTICE 352 OF 1984

TITUS RIVER IRRIGATION BOARD, DIVISION OF CERES, CAPE PROVINCE.—ASSIGNMENT OF FUNCTIONS, POWERS AND DUTIES

By virtue of the powers delegated to me by Government Notice 2669 of 18 December 1981, I, Johan Ernst Friedrich Winter, in my capacity as Assistant Director in the Department of Environment Affairs, hereby assign to the Ixopo Irrigation Board the functions, powers and duties defined in section 89 (1) (a), (b), (c), (d), (e), (f) and (g) of the Water Act, 1956 (Act 54 of 1956).

J. E. F. WINTER, Assistant Director: Department of Environment Affairs.

(8 June 1984)

NOTICE 353 OF 1984

DEPARTMENT OF POSTS AND TELECOMMUNICATIONS

I, Henry Odendal Bester, Postmaster General, under section 2B (1) (e) of the Post Office Act, 1958 (Act 44 of 1958), and with the approval of the Minister of Posts and Telecommunications, hereby determine the fees, rates and charges to be demanded or received in respect of the telecommunication services, as set out in the Appendix.

H. O. BESTER, Postmaster General.

APPENDIX

1.0 In this Appendix the term "Tariff" means the Tariff for Telecommunication Services announced by Government Notice 1192 of 1 July 1977, as amended.

2.0 Item 1.0 of the Tariff is hereby amended by the addition of the following:

	Installation and other charges	Monthly rental, unless otherwise stated
<p>1.4 Free rental and installation: In respect of one main telephone service for residential purposes for a Post Office pensioner (all races), the widow of such a pensioner as well as the widow of a deceased Post Office official who shared in or qualified for the concession of a semi-official telephone service during his term of service or who would have qualified therefore in terms of current instructions if such concession did not exist during his term in service: Provided that such widows shall furnish satisfactory proof to the Postmaster General that they have not remarried; and provided further that the concession shall lapse as soon as they remarry ...</p> <p>1.4.1 Any benefit in terms of item 1.4 shall be valid only with effect from the telephone account following the date on which the beneficiary applied in writing to the Postmaster General: Provided that the Postmaster General may grant a credit on a previous account."</p>	<p>NONE</p>	<p>NONE</p>

3.0 Item 2.0 van die Tarieflys word hierby deur die byvoeging van die volgende gewysig:

	Installeer- en ander koste	Maandelikse huur, tensy anders vermeld
"2.4 Gratis huur en installering: Vir iemand bedoel in item 1.4 en onderworpe aan die voorbehoudsbepalings in daardie item	GEEN	GEEN"

4.0 Item 3.0 van die Tarieflys word hierby deur die byvoeging van die volgende gewysig:

	Installeer- en ander koste	Maandelikse huur, tensy anders vermeld
"3.4 Gratis huur en installering: Vir iemand bedoel in item 1.4 en onderworpe aan die voorbehoudsbepalings in daardie item	GEEN	GEEN"

5.0 Item 4.0 van die Tarieflys word hierby deur die byvoeging van die volgende gewysig:

	Installeer- en ander koste	Maandelikse huur, tensy anders vermeld
"4.4 Gratis huur en installering: Vir iemand bedoel in item 1.4 en onderworpe aan die voorbehoudsbepalings in daardie item	GEEN	GEEN"

6.0 Item 5.0 van die Tarieflys word hierby deur die byvoeging van die volgende gewysig:

	Installeer- en ander koste	Maandelikse huur, tensy anders vermeld
"5.3 Gratis huur en installering: Vir iemand bedoel in item 1.4 en onderworpe aan die voorbehoudsbepalings in daardie item	GEEN	GEEN"

7.0 Item 7.0 van die Tarieflys word hierby deur die byvoeging van die volgende gewysig:

	Installeer- en ander koste	Maandelikse huur, tensy anders vermeld
"7.4 Gratis huur en installering: Vir iemand bedoel in item 1.4 en onderworpe aan die voorbehoudsbepalings in daardie item	GEEN	GEEN"

8.0 Item 8.0 van die Tarieflys word hierby deur die byvoeging van die volgende gewysig:

	Installeer- en ander koste	Maandelikse huur, tensy anders vermeld
"8.1.5 Gratis huur en installering: T.o.v. een binnenshuise bylyn wat op die hooftelefoondiens van afgetrede Postmeesters-generaal sowel as Adjunk-postmeesters-generaal of hul weduwees afgeheg is, onderworpe aan die voorbehoudsbepalings wat in item 1.4 vir die betrokke hooftelefoondiens uiteengesit is	GEEN	GEEN"

3.0 Item 2.0 of the Tariff is hereby amended by the addition of the following:

	Installation and other charges	Monthly rental, unless otherwise stated
"2.4 Free rental and installation: For someone intended in item 1.4 and subject to the provisos in that item	NONE	NONE"

4.0 Item 3.0 of the Tariff is hereby amended by the addition of the following:

	Installation and other charges	Monthly rental, unless otherwise stated
"3.4 Free rental and installation: For someone intended in item 1.4 and subject to the provisos in that item	NONE	NONE"

5.0 Item 4.0 of the Tariff is hereby amended by the addition of the following:

	Installation and other charges	Monthly rental, unless otherwise stated
"4.4 Free rental and installation: For someone intended in item 1.4 and subject to the provisos in that item	NONE	NONE"

6.0 Item 5.0 of the Tariff is hereby amended by the addition of the following:

	Installation and other charges	Monthly rental, unless otherwise stated
"5.3 Free rental and installation: For someone intended in item 1.4 and subject to the provisos in that item	NONE	NONE"

7.0 Item 7.0 of the Tariff is hereby amended by the addition of the following:

	Installation and other charges	Monthly rental, unless otherwise stated
"7.4 Free rental and installation: For someone intended in item 1.4 and subject to the provisos in that item	NONE	NONE"

8.0 Item 8.0 of the Tariff is hereby amended by the addition of the following:

	Installation and other charges	Monthly rental, unless otherwise stated
"8.1.5 Free rental and installation: In respect of one indoor extension terminated on the main telephone service of retired Postmasters General as well as Deputy Postmasters General or their widows, subject to the provisos as set out in item 1.4 for the relative main telephone service	NONE	NONE"

9.0 Item 16.28 van die Tarieflys word hierby deur die volgende item vervang:

	Installeer- en ander koste	Maandelikse huur, tensy anders vermeld
"16.28 Verandering van die naam en/of titel van die klient: 16.28.1 Registrasiegeld wat per afsonderlike geval by 'n spesifieke adres betaalbaar is, ongeag die getal dienste wat betrokke is, met inbegrip van gevalle waar 'n bestaande diens nie opgeskort is nie en op 'n nuwe klient se naam oorgedra word 16.28.2 Registrasiegeld waar 'n bestaande diens nie opgeskort is nie en oorgedra word op naam van 'n nuwe klient wat ingevolge items 1.4, 2.4, 3.4, 4.4, 5.3 en 7.4 vir gratis huur kwalifiseer.....	10,00 GEEN	— —"

10.0 Item 17.1.2 van die Tarieflys word hierby deur die byvoeging van die volgende voetnoot tot die Tabel gewysig:

"(j) Afgetrede Posmeesters-generaal of hul weduwees wat kragtens items 1.4, 2.4, 3.4, 4.4, 5.3 en 7.4 vir gratis huur en installering kwalifiseer, word nie met die koste van enige oproep, met inbegrip van oproepe na ander lande, gedebiteer nie terwyl ander Poskantoorpensioentrekkers, hul weduwees of die weduwees van afgestorwe Poskantoorampptenare wat op soortgelyke grondslag vir gratis huur en installering kwalifiseer nie met die koste vir oproepen, met inbegrip van direk geskakelde oproepe na ander lande, gedebiteer word nie, soos hierna uiteengesit word:

- Afgetrede Adjunk-posmeesters-generaal of hul weduwees: Eerste 1 000 oproepen of gedeelte daarvan wat per debiettydperk op die klient se teller registreer
- Alle ander: Eerste 50 oproepen of gedeelte daarvan wat per debiettydperk op die klient se teller registreer"

11.0 DATUM VAN INWERKINGTREDING:

Hierdie wysigings van die Tarieflys word geag op 1 April 1984 in werking te getree het.

(8 Junie 1984)

9.0 Item 16.28 of the Tariff is hereby replaced by the following item:

	Installation and other charges	Monthly rental, unless otherwise stated
"16.28 Change of the name and/or title of the client: 16.28.1 Registration fee payable per individual case at a specific address, irrespective of the number of services involved, including cases where an existing service is not suspended and is transferred to a new client's name 16.28.2 Registration fee where an existing service is not suspended and is transferred to the name of a new client who qualifies for free rental in terms of items 1.4, 2.4, 3.4, 4.4, 5.3 and 7.4	10,00 NONE	— —"

10.0 Item 17.1.2 of the Tariff is hereby amended by the addition of the following foot-note to the Table:

"(j) Retired Postmasters General or their widows who qualify for free rental and installation in terms of items 1.4, 2.4, 3.4, 4.4, 5.3 and 7.4 are not debited with the cost of any calls, including calls to other countries, while other Post Office pensioners, their widows or the widows of deceased Post Office officials who qualify for free rental and installation are not debited with the cost for call units, including direct-dialled calls to other countries, as explained below:

- Retired Deputy Postmasters General or their widows: First 1 000 call units or part thereof that register on the client's meter per debit period
- All others: First 50 call units or part thereof that register on the client's meter per debit period"

11.0 DATE OF COMMENCEMENT:

These amendments to the Tariff shall be deemed to have come into operation on 1 April 1984.

(8 June 1984)

KENNISGEWING 354 VAN 1984

DEPARTEMENT VAN GEMEENSKAPSONTWIKKELING

KENNISGEWING VAN BEPALING VAN VERGOEDING

Aan:

Die persone aangedui in die onderstaande Bylae en alle belanghebbende partye

1. Die eiendom hierna beskrywe waarvan u na die wete van die Gemeenskapontwikkelingsraad ingestel by artikel 2 van die Wet op Gemeenskapontwikkeling, 1966 (Wet 3 van 1966), soos gewysig, die geregistreerde eienaar is, word deur genoemde Gemeenskapontwikkelingsraad benodig.

2. Derhalwe is die eiendom kragtens paragraaf (a) van subartikel (1) van artikel 38 van gemelde Wet op 28 Januarie 1983 onteien.

3. Geen eise ten opsigte van vergoeding soos bepaal kragtens artikel 9 (1) (b) van Wet 63 van 1975 is ontvang nie.

4. Derhalwe het die Gemeenskapontwikkelingsraad die vergoeding ingevolge artikel 10 (2) van Wet 63 van 1975 bepaal soos in Bylae hiertoe aangedui.

NOTICE 354 OF 1984

DEPARTMENT OF COMMUNITY DEVELOPMENT

NOTICE OF DETERMINATION OF COMPENSATION

To:

The person mentioned in the undermentioned Schedule and to all interested parties

1. The person described hereunder of which you are to the knowledge of the Community Development Board, established under section 2 of the Community Development Act, 1966 (Act 3 of 1966), as amended, the registered owner is required by the said Community Development Board.

2. The property was therefore expropriated on 28 January 1983 in terms of paragraph (a) of subsection (1) of section 38 of the said Act.

3. No claim in respect of the compensation was received as laid down in terms of section 9 (1) (b) of Act 63 of 1975.

4. Therefore the Community Development Board has in terms of section 10 (2) of Act 63 of 1975, determined the compensation at the amounts as per attached Schedule.

5. Alle belanghebbendes word versoek om verhoë wat hulle in verband hiermee wil maak skriftelik binne 30 dae vanaf datum van hierdie kennisgewing by die Streekverteenwoordiger, Departement van Gemeenskapontwikkeling, Privaatsak X18, Johannesburg, 2000, Tel. 28-3500, in te dien.

6. Hierdie advertensie word ingevolge die bepalings van artikel 7 (5) van Wet 63 van 1975 gepubliseer.

Gedateer te Johannesburg op hede die 8ste dag van Junie 1984.

P. C. VAN BLOMMESTEIN, Direkteur-generaal, p/a Streekverteenwoordiger, Departement van Gemeenskapontwikkeling, Privaatsak X18, Johannesburg, 2000.

5. All interested parties are requested to submit in writing within 30 days from the date hereof any representations they may wish to make in connection herewith to the Regional Representative, Community Development, Private Bag X18, Johannesburg, 2000, Tel. 28-3500.

6. This advertisement is published in terms of the provisions of section 7 (5) of Act 63 of 1975.

Dated at Johannesburg this 8th day of June 1984.

P. C. VAN BLOMMESTEIN, Director-General, c/o Regional Representative, Department of Community Development, Private Bag X18, Johannesburg, 2000.

BYLAE

GELUKSDAL, UNAVILLE

Geregistreeerde eienaar	Erf	Titelakte	Vergoeding
Mre. S. en K. F. Holdings (Pty) Ltd	Hoewe 17	T 15584/72 van 8 Junie 1972.....	R15 350 + 10%

SCHEDULE

GELUKSDAL, UNAVILLE

Registered owner	Stand No.	Title Deed	Compensation
Messrs S. and K. F. Holdings (Pty) Ltd	Holding 17	T 15584/72 of 8 June 1972.....	R15 350 + 10%

(8 Junie 1984)/(8 June 1984)

KENNISGEWING 355 VAN 1984

**DEPARTEMENT VAN GESONDHEID EN WELSYN
DIE SUID-AFRIKAANSE APTEKERSRAAD**

**KENNISGEWING KRAGTENS ARTIKEL 45 (2) VAN
DIE WET OP APTEKERS, 1974 (WET 53 VAN 1974)**

Besonderhede rakende onderstaande persone wat na behoorlike ondersoek na hul gedrag deur die Suid-Afrikaanse Aptekersraad aan skandelijke of onbetaamlike gedrag skuldig bevind is, word hierby vir algemene inligting bekendgemaak:

NOTICE 355 OF 1984

**DEPARTMENT OF HEALTH AND WELFARE
THE SOUTH AFRICAN PHARMACY BOARD**

**NOTICE IN TERMS OF SECTION 45 (2) OF THE
PHARMACY ACT, 1974 (ACT 53 OF 1974)**

Particulars of the following persons found guilty of improper or disgraceful conduct by the South African Pharmacy Board after due inquiry into their conduct, are published for general information:

Naam van persoon	Aard van oortreding waaraan skuldig bevind	Straf opgelê
Willem Petrus Bosman	Skandelijke gedrag: Verskaffing van 'n vervalste afskrif van 'n voorskrif vir medisyne	Geskors vir drie maande, vonnis vir een jaar opgeskort.
Francois Gerrit de Wet Smit	Onbetaamlike gedrag: Buitensporige heffing vir medisyne op voorskrif verskaf	Geskors vir twee maande, vonnis vir drie jaar opgeskort.

D. A. DUGGAN, Registrateur.

Name of persons	Nature of offence of which found guilty	Penalty imposed
Willem Petrus Bosman	Disgraceful conduct: Supply of a forged copy of a prescription for medicines	Suspended for three months, sentence suspended for one year.
Francois Gerrit de Wet Smit	Improper conduct: Excessive charges for medicines supplied on prescription	Suspended for two months, sentence suspended for three years.

D. A. DUGGAN, Registrar.

(8 Junie 1984)/(8 June 1984)

KENNISGEWING 358 VAN 1984—NOTICE 358 OF 1984

DEPARTEMENT VAN GESONDHEID EN WELSYN—DEPARTMENT OF HEALTH AND WELFARE

WET OP DIE BEHEER VAN MEDISYNE EN VERWANTE STOWWE, 1965 (WET 101 VAN 1965)
MEDICINES AND RELATED SUBSTANCES CONTROL ACT, 1965 (ACT 101 OF 1965)

REGISTRASIE VAN MEDISYNE—REGISTRATION OF MEDICINES

Hierby word ingevolge artikel 17 (a) van die Wet op die Beheer van Medisyne en Verwante Stowwe, 1965 (Wet 101 van 1965), vir algemene inligting bekendgemaak dat die Medisynebeheerraad, ingestel by artikel 2 van genoemde Wet, die volgende medisyne geregistreer het:

It is hereby notified for general information, in terms of section 17 (a) of the Medicines and Related Substances Control Act, 1965 (Act 101 of 1965), that the Medicines Control Council, established by section 2 of the said Act, has registered the following medicines.

Registrasie No. Registration No.	Naam van medisyne Name of medicine	Bereidingsvorm Form of preparation	Aktiewe bestanddele Active ingredients	Hoeveelheid Quantity	Voorwaardes vir registrasie Conditions of registration	Applikant Applicant
B/2.8/805	Pyralen Tablette/Tablets	Tablette/Tablets	Elke tablet bevat/Each tablet contains: Parasetamol/Paracetamol	500 mg.....	—	G. M. P. Pharmaceutical Co. (Pty) Ltd.
B/2.8/978	Owa Pain-Free Tablette/ Tablets	Tablette/Tablets	Elke tablet bevat/Each tablet contains: Aspirien/Aspirin	400 mg.....	—	M. I. Desatnik.
B/2.8/980	Marshall's Pain Tablette/ Tablets	Tablet/Tablet	Elke tablet bevat/Each tablet contains: Aspirien/Aspirin	333 mg.....	—	Marshall's Chemical Co. (Edms.) Bpk./ (Pty) Ltd.
B/2.7/1014	Sublimaze (Fentanyl) 2 mℓ	Inspuiting/Injection	Fentanielsitraat, ekwivalent aan fentaniël/Fenta- nyl citrate, equivalent to fentanyl	0,05 mg per mℓ.....	Advertensie slegs aan die beroepse/Advertising to the professions only	Janssen Pharmaceutica (Pty) Ltd.
B/2.8/1480	Cetapon (Yellow) Tablet/ Cetapon (Green) Tab- lets	Tablette/Tablets	Elke tablet (groen en geel) bevat/Each tablet (green and yellow) contains: Parasetamol/Paracetamol	500 mg.....	—	Pharmakon Manufacturing Laboratories (Pty) Ltd.
N/15.4/22	Restatear Eye Drops	Oogdruppels/Eye drops ..	Hipromellose/Hypromellose	3 mg per mℓ.....	—	Restan Laboratories (Pty) Ltd.
N/5.7.1/36	Triludan	Tablet	Terfenadien/Terfenadine.....	60 mg per tablet	—	Dow Chemical Africa (Pty) Ltd.
N/6.1/46.....	Intropin prefilled syringe 400 mg	Inspuiting/Injection	Dopamienhidrochloried/Dopamine hydrochlo- ride	400 mg per voorafge vulde spuit/prefilled syringe	Advertensie slegs aan die beroepse/Advertising to the professions only	A.H.S.C./South Africa (Pty) Ltd.
N/20.2/146.....	Proloprim Tablets 100 mg	Tablet	Trimetoprim/Trimethoprim.....	100 mg per tablet.....	Advertensie slegs aan die beroepse/Advertising to the professions only	Wellcome (Pty) Ltd.
N/20.2/147.....	Proloprim Tablets 300 mg	Tablet	Trimetoprim/Trimethoprim.....	300 mg per tablet.....	Advertensie slegs aan die beroepse/Advertising to the professions only	Wellcome (Pty) Ltd.
P/20.1.2/45	Binotal Capsules 250 mg	Kapsules/Capsules	Ampisillien-trihidraat, ekwivalent aan ampisil- lien/Ampicillin trihydrate, equivalent to ampi- cillin	250 mg per kapsule/cap- sule	Advertensie slegs aan die beroepse/Advertising to the professions only	Bayer-Miles (Pty) Ltd.
P/20.1.2/46	Binotal Capsules 500 mg	Kapsules/Capsules	Ampisillien-trihidraat, ekwivalent aan ampisil- lien/Ampicillin trihydrate equivalent to ampi- cillin	500 mg per kapsule/cap- sule	Advertensie slegs aan die beroepse/Advertising to the professions only	Bayer-Miles (Pty) Ltd.
P/20.1.2/47	Binotal Injection	Poeier vir inspuiting/ Powder for injection	Ampisillien-natrium, ekwivalent aan ampisil- lien/Ampicillin sodium, equivalent to ampi- cillin	500 mg per ampule/am- poule	Advertensie slegs aan die beroepse/Advertising to the professions only	Bayer-Miles (Pty) Ltd.

Registrasie No. Registration No.	Naam van medisyne Name of medicine	Bereidingsvorm Form of preparation	Aktiewe bestanddele Active ingredients	Hoeveelheid Quantity	Voorwaardes vir registrasie Conditions of registration	Applikant Applicant
P/4/166	Neo-Lidocaton Forte 3 %	Inspuiting/Injection	Lidokaïenhydrochloried/Lidocaine hydrochloride	30 mg	Advertensie slegs aan die beroepe/Advertising to the professions only	Swisspharm (Pty) Ltd.
P/4/167	Lidocaton 2 % with Epinephrine 1:80'000	Inspuiting/Injection	Vasopressin/Vasopressin 1-norepinefrien/1-norepinephrine Lidokaïenhydrochloried/Lidocaine hydrochloride	0,25 i.e./i.u. 0,02 mg per ml	Advertensie slegs aan die beroepe/Advertising to the professions only	Swisspharm (Pty) Ltd.
P/4/168	Neo-Lidocaton 2 %	Inspuiting/Injection	Epinefrien/Epinephrine Lidokaïenhydrochloried/Lidocaine hydrochloride	0,0138 mg per ml	Advertensie slegs aan die beroepe/Advertising to the professions only	Swisspharm (Pty) Ltd.
P/7.1.3/183	Sinepress	Tablet	Vasopressien/Vasopressin 1-Norepinefrien/Norepinephrine Metieldopa, ekwivalent aan anhidriese metieldopa/Methyl-dopa, equivalent to anhydrous methyl-dopa	0,25 i.e./i.u. 0,02 mg per ml 250 mg per tablet	Advertensie slegs aan die beroepe/Advertising to the professions only	Rolab (Pty) Ltd.
P/11.4/253	Betaclomin Gel	Suspensie/Suspension	Disiklomiënhydrochloried/Dicyclome hydrochloride Aluminiumhidroksiedjel, ekwivalent aan gedroogde aluminiumhidroksiedjel/Aluminiumhydroxide gel, equivalent to dried aluminiumhydroxide gel Ligte magnesiumoksied/Light magnesiumoxide	5 mg	—	Be-Tabs Pharmaceuticals (Pty) Ltd.
P/3.1.1./259	Articulen 25 mg Capsules	Kapsule/Capsule	Indometasien/Indomethacin	400 mg 200 mg per 10 ml suspensie/suspension 25 mg per kapsule/capsule	Advertensie slegs aan die beroepe/Advertising to the professions only	Rolab (Pty) Ltd.
Q/21.1/39	Actrapid HM	Inspuiting/Injection	Ensimaties veranderde vark neutrale monokomponentinsulien (chemies identies aan menslike insulien/Enzymatically modified porcine neutral monocomponent insulin chemical identical to human insulin)	100 i.e./i.u. per ml	Advertensie slegs aan die beroepe/Advertising to the professions only	Novo Industries (Pharmaceuticals) (Pty) Ltd.
Q/21.1/42	Monotard HM	Inspuiting/Injection	Ensimaties veranderde varkmonokomponentinsulien suspensie (gemeng) (chemies identies aan menslike insulien)/Enzymatically modified porcine monocomponent insulin zinc suspension (mixed) (chemically identical to human insulin)	100 i.u. per ml	Advertensie slegs aan die beroepe/Advertising to the professions only	Novo Industries (Pharmaceuticals) (Pty) Ltd.
Q/18.1/70	Tensin Tablets	Tablet	Sprionolaktoon/Spironolactone	25 mg per tablet	Advertensie slegs aan die beroepe/Advertising to the professions only	Rolab (Pty) Ltd.
Q/20.2.6/101	Anaerobyl Tablets 250 mg	Tablet	Metronidasool/Metronidazole	250 mg per tablet	Advertensie slegs aan die beroepe/Advertising to the professions only	G. D. Searle (South Africa) (Pty) Ltd.
Q/20.2.6/102	Anaerobyl Tablets 500 mg	Tablet	Metronidasool/Metronidazole	500 mg per tablet	Advertensie slegs aan die beroepe/Advertising to the professions only	G. D. Searle (South Africa) (Pty) Ltd.

Registrasie No. Registration No.	Naam van medisyne Name of medicine	Bereidingsvorm Form of preparation	Aktiewe bestanddele Active ingredients	Hoeveelheid Quantity	Voorwaardes vir registrasie Conditions of registration	Applikant Applicant
Q/7.5/104	Bezalip	Tablet	Bezafibraat/Bezafibrate	200 mg per tablet	Advertensie slegs aan die beroepe/Advertising to the professions only	Boehringer Mannheim (SA) (Pty) Ltd.
Q/3.1/148	Antiflam 200	Tablet	Ibuprofen	200 mg per tablet	Advertensie slegs aan die beroepe/Advertising to the Professions only	Rolab (Pty) Ltd.
Q/3.1/149	Antiflam 400	Tablet	Ibuprofen	400 mg per tablet	Advertensie slegs aan die beroepe/Advertising to the professions only	Rolab (Pty) Ltd.
Q/11.5/150	Frulax	Jel/Gel	Cassia angustifolia en/and cassia fistula, ekwivalent aan/ekwivalent to hidroksiantrasienderivate bereken as sennosied B/hydroxyanthracene derivatives calculated as sennoside B	0,204 g per 100 g jel/gel	—	Petersen Ltd.
Q/2.6.5/169	Haloperidol Tablets 1,5 mg	Tablet	Haloperidol	1,5 mg per tablet	Advertensie slegs aan die beroepe/Advertising to the professions only	Vita Pharmaceuticals (Pty) Ltd.
Q/2.6.5/170	Haloperidol Tablets 5 mg	Tablet	Haloperidol	5 mg per tablet	Advertensie slegs aan die beroepe/Advertising to the professions only	Vita Pharmaceuticals (Pty) Ltd.
Q/2.5/174	Carbamazepine Tablets 200 mg	Tablet	Karbamasepien/Carbamazepine	200 mg per tablet	Advertensie slegs aan die beroepe/Advertising to the professions only	Rolab (Pty) Ltd.
Q/21.8.2/194	Eugynon ED	Tablet	Norgestrei	0,5 mg	Advertensie slegs aan die beroepe/Advertising to the professions only	Berlirmed (Pty) Ltd.
Q/2.9/209	Aspegic 100 for children and infants	Poeier vir oplossing/ Powder for solution	Etinielestradiol/Ethinylestradiol	0,05 mg per tablet	—	Adcock-Ingram Laboratories Ltd.
Q/2.9/210	ASPEGIC 500	Poeier vir oplossing/ Powder for solution	Lisienasetiëlsalilaat, ekwivalent aan aspirien/ Lysine acetylsalicylate, equivalent to aspirin	0,1 g per sakkie/sachet	—	Adcock-Ingram Laboratories Ltd.
Q/2.9/211	Aspegic 1 000	Poeier vir oplossing/ Powder for solution	Lisienasetiëlsalilaat, ekwivalent aan aspirien/ Lysine acetylsalicylate, equivalent to aspirin	0,5 g per sakkie/sachet	—	Adcock-Ingram Laboratories Ltd.
Q/29/231	Takus 5	Gevriesdroogde poeier vir inspuiting/Lyophilised powder for injection	Seruletied-diëtiëlamien, ekwivalent aan seruletied vrysuur/Ceruletide diethylamine, equivalent to ceruletide free acid	5 µg per flessie/vial	Advertensie slegs aan die beroepe/Advertising to the professions only	Chemfarma Laboratories (Pty) Ltd.
Q/29/232	Takus 30	Gevriesdroogde poeier vir inspuiting/Lyophilised powder for injection	Seruletied-diëtiëlamien, ekwivalent aan seruletied vrysuur/Ceruletide diethylamine, equivalent to ceruletide free acid	30 µg per flessie/vial	Advertensie slegs aan die beroepe/Advertising to the professions only	Chemfarma Laboratories (Pty) Ltd.
Q/2.6/249	Medopam 10 mg	Tablet	Oksasepam/Oxazepam	10 mg per tablet	Advertensie slegs aan die beroepe/Advertising to the professions only	Medpharm Laboratories (Pty) Ltd.
Q/2.6/250	MEDOPAM 15 mg	Tablet	Oksasepam/Oxazepam	15 mg per tablet	Advertensie slegs aan die beroepe/Advertising to the professions only	Medpharm Laboratories (Pty) Ltd.
Q/2.6/251	Medopam 30 mg	Tablet	Oksasepam/Oxazepam	30 mg per tablet	Advertensie slegs aan die beroepe/Advertising to the professions only	Medpharm Laboratories (Pty) Ltd.
Q/20.2/265	Triglobe Suspension	Suspensie/Suspension	Trimetoprim/Trimethoprim	45 mg	Advertensie slegs aan die beroepe / Advertising to the professions only	Adcock-Ingram Laboratories Ltd.
			Sulfadiasien/Sulphadiazine	205 mg per 5 ml		

Registrasie No. Registration No.	Naam van medisyne Name of medicine	Bereidingsvorm Form of preparation	Aktiewe bestanddele Active ingredients	Hoeveelheid Quantity	Voorwaardes vir registrasie Conditions of registration	Applikant Applicant
Q/20.2/266.....	Triglobe Tablets 0,5 g....	Tablet.....	Trimetoprim/Trimethoprim..... Sulfadiazien/Sulphadiazine.....	90 mg..... 410 mg per tablet	Advertensie slegs aan die beroepe/Advertising to the professions only	Adcock-Ingram Laboratories Ltd.
Q/20.2/267.....	Triglobe Tablets 1 g.....	Tablet.....	Trimetoprim/Trimethoprim..... Sulfadiazien/Sulphadiazine.....	180 mg..... 820 mg per tablet	Advertensie slegs aan die beroepe/Advertising to the professions only	Adcock-Ingram Laboratories Ltd.
Q/20.2.2/281.....	Canesten 1 Vaginal Tablet	Tablet.....	Klotrimasool/Clotrimazole.....	500 mg per tablet.....	Advertensie slegs aan die beroepe/Advertising to the professions only	Bayer-Miles (Pty) Ltd.
Q/10.1/284.....	Halls Menthol-Eucalyptus Ice Blue	Suigtablet/Lozenge.....	Mentol/Menthol..... Bloekomolie/Eucalyptus Oil.....	12 mg..... 5,1 mg per suigtablet/lozenge	---	Chamberlain's (Pty) Ltd.
Q/10.1/285.....	Halls Menthol-Eucalyptus Honey & Lemon	Suigtablet/Lozenge.....	Mentol/Menthol..... Bloekomolie/Eucalyptus oil.....	8,4 mg..... 7,2 mg per suigtablet/lozenge	---	Chamberlain's (Pty) Ltd.
Q/10.2/289.....	Normalin Syrup.....	Stroop/Syrup.....	Prokaterolhidrochloriedhemihidraat/Procaterol hydrochloride hemihydrate	0,025 mg per 5 ml.....	---	Noristan Laboratories (Pty) Ltd.
Q/21.2/290.....	Dextin 500.....	Tablet.....	Metformienhidrochloried/Metformin hydrochloride	500 mg per tablet.....	Advertensie slegs aan die beroepe/Advertising to the professions only	Rolab (Pty) Ltd.
Q/21.1/291.....	Dextin 850.....	Tablet.....	Metformienhidrochloried/Metformin hydrochloride	850 mg per tablet.....	Advertensie slegs aan die beroepe/Advertising to the professions only	Rolab (Pty) Ltd.
Q/2.6/292.....	Oxaline 15 mg.....	Tablet.....	Oksasepam/Oxazepam.....	15 mg per tablet.....	Advertensie slegs aan die beroepe/Advertising to the professions only	Rolab (Pty) Ltd.
Q/2.6/293.....	Oxaline 30 mg.....	Tablet.....	Oksasepam/Oxazepam.....	30 mg per tablet.....	Advertensie slegs aan die beroepe/Advertising to the professions only	Rolab (Pty) Ltd.
Q/10.2/294.....	Normalin Tablet 0,025 mg	Tablet.....	Prokaterolhidrochloriedhemihidraat/Procaterol hydrochloride hemihydrate	0,025 mg per tablet.....	---	Noristan Laboratories (Pty) Ltd.
Q/10.2/295.....	Normalin Tablet 0,05 mg	Tablet.....	Prokaterolhidrochloriedhemihidraat/Procaterol hydrochloride hemihydrate	0,05 mg per tablet.....	---	Noristan Laboratories (Pty) Ltd.
Q/2.8/302.....	Meridol-D Paediatric Syrup	Stroop/Syrup.....	Parasetamol/Paracetamol..... Kodejensfosfaat/Codeine phosphate..... Difenhidramienhidrochloried/Diphenhydramine hydrochloride	150 mg..... 4 mg 10 mg per 5 ml	---	Ormet (Pty) Ltd.
Q/34/310.....	Diluting Solution for Oncovin	Inspuiting/Injection.....	Natriumchloried/Sodium chloride..... Bensielalkohol/Benzyl alcohol.....	90 mg..... 0,09 ml per 10 ml	---	Eli Lilly (S.A.) (Pty) Ltd.
Q/3.1/318.....	Synflex.....	Tablet.....	Naproxennatrium/Naproxen sodium.....	275 mg per tablet.....	Advertensie slegs aan die beroepe/Advertising to the professions only	Adcock-Ingram Laboratories Ltd.
Q/20.1.1/319.....	Garamycin Premix IV solution 80 mg/100 ml	Intraveneuse oplossing in Vialflex-plastiekhouders/ Intravenous solution in Vialflex plastic containers	Gentamisiensulfaat/Gentamicin sulphate, ekwivalent aan/equivalent to gentamisien/gentamicin	80 mg per 100 ml.....	Advertensie slegs aan die beroepe/Advertising to the professions only	Scherag (Pty) Ltd.
Q/20.1.1/320.....	Garamycin Premix IV solution 80 mg/50 ml	Intraveneuse oplossing in Vialflex-plastiekhouders/ Intravenous Solution in Vialflex plastic containers	Gentamisien sulfaat/Gentamicin sulphate, ekwivalent aan/equivalent to gentamisien/gentamicin	80 mg per 50 ml.....	Advertensie slegs aan die beroepe/Advertising to the professions only	Scherag (Pty) Ltd.

Registrasie No. Registration No.	Naam van medisyne Name of medicine	Bereidingsvorm Form of preparation	Aktiewe bestanddele Active ingredients	Hoeveelheid Quantity	Voorwaardes vir registrasie Conditions of registration	Applikant Applicant
Q/20.2.6/333	Chloroquine Phosphate 250 mg Tablets (Rolab)	Tablet	Chlorokienfosfaat/Chloroquine phosphate	250 mg per tablet	Advertensie slegs aan die beroepe as gebruik word vir die behandeling van malaria/Advertising to the professions only, if used for the treatment of malaria	Roiab (Pty) Ltd.
Q/2.9/335	Syndol Syrup	Stroop/Syrup	Parasetamol/Paracetamol	120 mg	—	Dow Chemicals Africa (Pty) Ltd.
Q/2.2/354	Dormonoc tablets 1 mg	Tablet	Doksielamiensuksinaat/Doxylamine succinate ..	5 mg	—	—
Q/2.2/355	Dormonoc tablets 2 mg	Tablet	Kodeienfosfaat/Codeine phosphate	5 mg	—	—
Q/2.7/356	Nubain	Inspuiting/Injection	Loprasolammesilaat, ekwivalent aan loprasolam/Loprazolam mesylate, equivalent to loprazolam	1 mg per tablet	Advertensie slegs aan die beroepe/Advertising to the professions only	Roussel Laboratories (Pty) Ltd.
Q/2.7/357	Nubain	Inspuiting/Injection	Loprasolammesilaat, ekwivalent aan loprasolam/Loprazolam mesylate, equivalent to loprazolam	2 mg per tablet	Advertensie slegs aan die beroepe/Advertising to the professions only	Roussel Laboratories (Pty) Ltd.
Q/33/358	Livalert Plus Elixir	Elikser/Elixir	Nalbufienhidrochloried/Nalbuphine hydrochloride	10 mg per ml	Advertensie slegs aan die beroepe/Advertising to the professions only	Du Pont de Nemours International S.A.—Pharmaceuticals Division.
Q/13.4.1/362	Cutaderm Cream	Room/Cream	Nalbufienhidrochloried/Nalbuphine hydrochloride	20 mg per 2 ml	Advertensie slegs aan die beroepe/Advertising to the professions only	Du Pont de Nemours International S.A.—Pharmaceuticals Division.
Q/13.4.1/363	Cutaderm Lotion	Wasmiddel/Lotion	Anhidriese kaffeien/Caffeine, anhydrous	150 mg	—	Restan Laboratories (Pty) Ltd.
Q/13.4.1/364	Cutaderm Ointment	Salf/Ointment	Lewerekstrak/Liver extract	90 mg	—	—
Q/13.4.1/365	Procutan Lotion 1 %	Wasmiddel/Lotion	Vitamiën B ₁ /Vitamin B ₁	9 mg	—	—
Q/6.1/366	Dobutrex Liquid	Inspuiting/Injection	Vitamiën B ₂ /Vitamin B ₂	4,5 mg	—	—
R/11.5/9	Emulsion of Liquid Paraffin with Agar (Lennon)	Emulsie/Emulsion	Vitamiën B ₆ /Vitamin B ₆	2,10 mg	—	—
R/13.4.1/14	Sicorten Cream	Room/Cream	Nikotienamied/Nicotinamide	30 mg	—	—
			Hidrokortisoon/Hydrocortisone	per 15 ml	—	—
			Hidrokortisoon/Hydrocortisone	5 mg per g	Advertensie slegs aan die beroepe/Advertising to the professions only	Scherag (Pty) Ltd.
			Hidrokortisoon/Hydrocortisone	5 mg per g	Advertensie slegs aan die beroepe/Advertising to the professions only	Scherag (Pty) Ltd.
			Hidrokortisoon/Hydrocortisone	5 mg per g	Advertensie slegs aan die beroepe/Advertising to the professions only	Scherag (Pty) Ltd.
			Hidrokortisoon/Hydrocortisone	10 mg per g	Advertensie slegs aan die beroepe/Advertising to the professions only	Scherag (Pty) Ltd.
			Dobutamienhidrochloried, ekwivalent aan dobutamien/dobutamine hydrochloride, equivalent to dobutamine	250 mg per 20 ml	Advertensie slegs aan die beroepe/Advertising to the professions only	Eli Lilly (S.A.) (Pty) Ltd.
			Aptekersparaffien/Liquid Paraffin	50 ml	—	Petersen Ltd.
			Agar	0,75 g per 100 ml	—	—
			Halometasoonmonohidraat/Halometasone monohydrate	0,05 g per 100 g room/cream	Advertensie slegs aan die beroepe/Advertising to the professions only	Ciba-Geigy (Pty) Ltd.

Registrasie No. Registration No.	Naam van medisyne Name of medicine	Bereidingsvorm Form of preparation	Aktiewe bestanddele Active ingredients	Hoeveelheid Quantity	Voorwaardes vir registrasie Conditions of registration	Applikant Applicant
R/13.4.1/15.....	Sicorten Ointment.....	Salf/Ointment.....	Halometasoonmonohidraat/Halometasone monohydrate	0,05 g per 100 g salf/ointment	Advertensie slegs aan die beroepe/Advertising to the professions only	Ciba-Geigy (Pty) Ltd.
R/13.4.1/16.....	Sicorten Plus.....	Room/Cream.....	Halometasoonmonohidraat/Halometasone monohydrate Triklosan/Triclosan.....	0,05 g..... 1,0 g per 100 g room/cream	Advertensie slegs aan die beroepe/Advertising to the professions only	Ciba-Geigy (Pty) Ltd.
R/3.1/19.....	Surgam 300.....	Tablet.....	Tiaprofeensuur/Tiaprofenic acid.....	300 mg per tablet.....	Advertensie slegs aan die beroepe/Advertising to the professions only	Roussel Laboratories (Pty) Ltd.
R/13.4.2/29.....	Tigason Capsules 10 mg	Kapsule/Capsule.....	Etretinaat/Etretinate.....	10 mg per kapsule/capsule	Advertensie slegs aan die beroepe/Advertising to the professions only	Roche Products (Pty) Ltd.
R/13.4.2/30.....	Tigason Capsules 25 mg	Kapsule/Capsule.....	Etretinaat/Etretinate.....	25 mg per kapsule/capsule	Advertensie slegs aan die beroepe/Advertising to the professions only	Roche Products (Pty) Ltd.
R/26/35.....	Farmorubicin 10 mg.....	Gevriesdroogde poeler vir inspuiting/ Freeze-dried powder for injection	4-epidoksonubisiënhydrochloried/4-epidoxorubicin hydrochloride	10 mg per flessie/vial.....	Advertensie slegs aan die beroepe/Advertising to the professions only	Farmitalia Carlo Erba (Chem-farma Laboratories (Pty) Ltd.)
R/26/36..... R/20.2.8/37.....	Farmorubicin 50 mg..... Zovirax tablets 200 mg...	Tablet.....	Asiklovir/Acyclovir.....	50 mg per flessie/vial 200 mg per tablet.....	Advertensie slegs aan die beroepe/Advertising to the professions only	Wellcome (Pty) Ltd.
R/26/56.....	Novatrone 4 mg.....	Inspuiting/Injection.....	Mitoksantroonhydrochloried, ekwivalent aan mitoksantroon, vrye basis/Mitoxantrone hydrochloride, equivalent to mitoxantrone, free base	4 mg per 2 ml flessie/vial	Advertensie slegs aan die beroepe/Advertising to the professions only	Lederle Laboratories (Pty) Ltd.
R/26/57.....	Novantrone 10 mg.....	Inspuiting/Injection.....	Mitoksantroonhydrochloried, ekwivalent aan mitoksantroon, vrye basis/Mitoxantrone hydrochloride, equivalent to mitoxantrone, free base	10 mg per 5 ml flessie/vial	Advertensie slegs aan die beroepe/Advertising to the professions only	Lederle Laboratories (Pty) Ltd.
R/26/58.....	Novantrone 20 mg.....	Inspuiting/Injection.....	Mitoksantroonhydrochloried, ekwivalent aan mitoksantroon, vrye basis/Mitoxantrone hydrochloride, equivalent to mitoxantrone, free base	20 mg per 10 ml flessie/vial	Advertensie slegs aan die beroepe/Advertising to the professions only	Lederle Laboratories (Pty) Ltd.
R/26/59.....	Novantrone 25 mg.....	Inspuiting/Injection.....	Mitoksantroonhydrochloried, ekwivalent aan mitoksantroon, vrye basis/Mitoxantrone hydrochloride, equivalent to mitoxantrone, free base	25 mg per 12,5 ml flessie/vial	Advertensie slegs aan die beroepe/Advertising to the professions only	Lederle Laboratories (Pty) Ltd.
R/26/60.....	Novantrone 30 mg.....	Inspuiting/Injection.....	Mitoksantroon hydrochloried, ekwivalent aan mitoksantroon, vrye basis/Mitoxantrone hydrochloride, equivalent to mitoxantrone, free base	30 mg per 15 ml flessie/vial	Advertensie slegs aan die beroepe/Advertising to the professions only	Lederle Laboratories (Pty) Ltd.
R/15.4/65.....	Beta-ophtiole 0,3 %.....	Oogdruppels/Eye drops..	Metipranolol.....	3 mg per ml.....	Advertensie slegs aan die beroepe/Advertising to the professions only	Restan Laboratories (Pty) Ltd.
R/15.4/66.....	Beta-ophtiole 0,6 %.....	Oogdruppels/Eye drops..	Metipranolol.....	6 mg per ml.....	Advertensie slegs aan die beroepe/Advertising to the professions only	Restan Laboratories (Pty) Ltd.

Registrasie No. Registration No.	Naam van medisyne Name of medicine	Bereidingsvorm Form of preparation	Aktiewe bestanddele Active ingredients	Hoeveelheid Quantity	Voorwaardes vir registrasie Conditions of registration	Applikant Applicant
R/10.2.2/69.....	Somophyllin DF Oral Liquid	Vloeistof/Liquid.....	Aminofillien, anhidries/Aminophylline, anhydrous (Ekwivalent aan anhidriese teofillien/Equivalent to anhydrous theophylline)	105 mg..... 90 mg per 5 ml 600 mg per tablet.....	—	Fisons Pharmaceuticals (Pty) Ltd.
R/3.1/71.....	Brufen 600.....	Tablets.....	Ibuprofen.....	600 mg per tablet.....	Advertensie slegs aan die beroepe/Advertising to the professions only	The Boots Company (South Africa) (Pty) Ltd.
R/2.9/90.....	Tenston SA Capsules	Kapsule/Capsule.....	Parasetamol/Paracetamol.....	200 mg.....	Advertensie slegs aan die beroepe/Advertising to the professions only	Covan Pharmaceutical Products (Pty) Ltd.
R/2.8/95.....	Painaway Liquid Paracetamol	Vloeistof/Liquid.....	Kodeïenfosfaat/Codeine phosphate..... Kafeïen/Caffeine..... Meprobamaat/Meprobamate.....	10 mg 30 mg 150 mg per kapsule/capsule 1 000 mg per 30 ml.....	—	Adcock-Ingram Laboratories Ltd.
R/5.2/96.....	Beta-Cardone Tablets 80 mg	Tablet.....	Sotalolhidrochloried/Sotalol hydrochloride.....	80 mg per tablet.....	Advertensie slegs aan die beroepe/Advertising to the professions only	Glaxo (Pty) Ltd.
R/5.2/97.....	Beta-Cardone Tablets 160 mg	Tablet.....	Sotalolhidrochloried/Sotalol hydrochloride.....	160 mg per tablet.....	Advertensie slegs aan die beroepe/Advertising to the professions only	Glaxo (Pty) Ltd.
R/20.1.2/106.....	Togram 300 mg Capsule	Kapsule/Capsule.....	Ampisillientrihidraat/Ampicillin trihydrate, ekwivalent aan/Equivalent to anhidriese ampisillien/anhydrous ampicillin	250 mg per kapsule/capsule	Advertensie slegs aan die beroepe/Advertising to the professions only	Reymar Pharmaceuticals (Pty) Ltd.
R/5.2/115.....	PUR-BLOKA S.R.....	Kapsules/Capsules.....	Propranololhidrochloried / Propranolol hydrochloride	160 mg per kapsule/capsule	Advertensie slegs aan die beroepe/Advertising to the professions only	Lennon Ltd.
R/2.9/125.....	Scripto-Gesic.....	Tablet.....	Parasetamol/Paracetamol..... Kaffeïenalkaloïed/Caffeine alkaloid..... Meprobamaat/Meprobamate..... Kodeïenfosfaat/Codeine phosphate.....	325 mg..... 32 mg 150 mg 8 mg per tablet	Advertensie slegs aan die beroepe/Advertising to the professions only	Propan Pharmaceuticals (Pty) Ltd.
R/15.4/128.....	Opulets Fluoresceïn.....	Oogoplossing / Ophthalmic solution	Natriumfluoresceïn/Fluoresceïn sodium.....	2,5 mg per 0,25 ml.....	—	Alcon Laboratories (SA) (Pty) Ltd.
R/28/131.....	Omnipaque Injection 300 mg l/ml (20 ml)	Inspuiting/Injection.....	Anhidriese ioheksol, ekwivalent aan jodium/ Iohexol, anhydrous, equivalent to iodine	647 mg per ml.....	—	Sterling Drug SA (Pty) Ltd.
R/28/132.....	Omnipaque Injection (300 mg l/ml (50 ml)	Inspuiting/Injection.....	Anhidriese ioheksol, ekwivalent aan jodium/ Iohexol, anhydrous, equivalent to iodine	300 mg per ml	—	Sterling Drug SA (Pty) Ltd.
R/28/133.....	Omnipaque Injection 350 mg l/ml (20 ml)	Inspuiting/Injection.....	Anhidriese ioheksol, ekwivalent aan jodium/ Iohexol, anhydrous, equivalent to iodine	755 mg per ml..... 350 mg per ml	—	Sterling Drug SA (Pty) Ltd.
R/28/134.....	Omnipaque Injection 350 mg l/ml (50 ml)	Inspuiting/Injection.....	Anhidriese ioheksol, ekwivalent aan jodium/ Iohexol, anhydrous, equivalent to iodine	755 mg per ml 350 mg per ml	—	Sterling Drug SA (Pty) Ltd.
R/15.4/145.....	Indoptol.....	Oogdruppels/Eye drops..	Indometasien/Indomethacin.....	10 mg per ml.....	Advertensie slegs aan die beroepe/Advertising to the professions only	MSD (Pty) Ltd.
R/20.2.3/153.....	Rozide.....	Tablet.....	Pirasinamied/Pyrazinamide.....	500 mg per tablet.....	Advertensie slegs aan die beroepe/Advertising to the professions only	Rolab (Pty) Ltd.
R/34/175.....	Clenzym Tablets.....	Bruistablet/Effervescent tablet	Pankreatien 6 x/Pancreatin 6x.....	2,5 mg per bruis-/effervescent tablet	—	Alcon Laboratories (SA) (Pty) Ltd.

Registrasie No. Registration No.	Naam van medisyne Name of medicine	Bereidingsvorm Form of preparation	Aktiewe bestanddele Active ingredients	Hoeveelheid Quantity	Voorwaardes vir registrasie Conditions of registration	Applikant Applicant
R/2.9/189	Tensolve Tension Head- ache Tablets	Tablet	Parasetamol/Paracetamol	400 mg	—	Hoechst Pharmaceuticals (Pty) Ltd.
			Kodeienfosfaat/Codeine phosphate	10 mg		
			Difenhidramienhidrochloried/Diphenhydramine hydrochloride	5 mg		
			Anhidriese kafeien/Anhydrous caffeine	50 mg per tablet		
R/17.1/209	Iracrium 2,5 ml Injection	Inspuiting/Injection	Atracuriumbesilaat/Atracurium besylate	25 mg per 2,5 ml	Advertensie slegs aan die beroep/Advertising to the professions only	Welcome (Pty) Ltd.
R/17.1/210	Iracrium 5 ml Injection ..	Inspuiting/Injection	Atracuriumbesilaat/Atracurium besylate	50 mg per 5 ml	Advertensie slegs aan die beroep/Advertising to the professions only	Wellcome (Pty) Ltd.
R/5.8/228	Endcol	Kapsule/Capsule	Parasetamol/Paracetamol	300 mg	—	Lennon Ltd.
			Askorbiensuur/Ascorbic acid	75 mg		
			Fenielefrienhidrochloried/Phenylephrine hydro- chloride	5 mg		
			Chloorfeniraminemaleaat / Chlorpheniramine maleate	2 mg		
			Anhidriese kafeien/Anhydrous caffeine	30 mg per kapsule/capsule		
R/5.8/247	Cepacol Cold Capsules...	Kapsule/Capsule	Parasetamol/Paracetamol	300 mg	—	Dow Chemical Africa (Pty) Ltd.
			Askorbiensuur/Ascorbic acid	75 mg		
			Anhidriese kafeien/Caffeine, anhydrous	30 mg		
			Chloorfeniraminemaleaat / Chlorpheniramine maleate	2 mg		
			Fenielefrienhidrochloried/Phenylephrine hydro- chloride	5 mg per kapsule/capsule		
R/10.2.1/292	Venteze Inhaler	Aerosol vir inaseming/ Aerosol for inhalation	Salbutamol	100 µg per afgemete do- sis/metered dose	—	Lennon Ltd.
S/18.1/11	Burinex Injection 0,5 mg/ml (2 ml ampoule)	Inspuiting/Injection	Bumetanied/Bumetanide	0,5 mg per ml	Advertensie slegs aan die beroep/Advertising to the professions only	Leo Laboratories (Pty) Ltd.
S/18.1/12	Burinex Injection 0,5 mg/ml (10 ml am- poule)	Inspuiting/Injection	Bumetanied/Bumetanide	0,5 mg per ml	Advertensie slegs aan die beroep/Advertising to the professions only	Leo Laboratories (Pty) Ltd.

(8 Junie 1984)/(8 June 1984)

KENNISGEWING 359 VAN 1984

DEPARTEMENT VAN JUSTISIE

SUID-AFRIKAANSE REGSKOMMISSIE

Die Suid-Afrikaanse Regskommissie stel ondersoek in na Termyne waarbinne regsdinge teen die staat ingestel moet word en ontvang graag gemotiveerde skriftelike voorstelle vir die ontwikkeling, verbetering, modernisering of hervorming van dié faset van die reg.

'n Memorandum en wetsontwerp wat die Kommissie se tentatiewe voorstelle bevat en wat as agtergrondinligting kan dien, is op aanvraag gratis by die Kommissie verkrygbaar.

Die Kommissie se kantore is op die Agtste Verdieping, Nederduits Gereformeerde Kerk, Sinodalesentrum, Visagiestraat 228, Pretoria. Korrespondensie moet asseblief gerig word aan—

Die Sekretaris
Suid-Afrikaanse Regskommissie
Privaatsak X668
0001 Pretoria
Telefoon: (012) 26-1121.

(8 Junie 1984)

KENNISGEWING 360 VAN 1984

SUID-AFRIKAANSE VERVOERDIENSTE

VOORDELE BETAALBAAR UIT DIE NUWE SPOORWEG- EN HAWESUPERANNUASIEFONDS.—WYLE NICO STANDER

Mnr. Nico Stander wat op 20 Desember 1922 gebore is en wat as 'n bestuurder (PVD) te Durban in diens van die Suid-Afrikaanse Vervoerdienste was, is op 3 Junie 1981 oorlede. Sy jongsbekende adres was Joubertstraat 82, Parow Vallei. Indien hy 'n wettige weduwee nagelaat het word sy versoek om voor 15 Junie 1984 met die Assistent-hoofbestuurder (Finansies), Afdeling Pensioene, Posbus 47, Suid-Afrikaanse Vervoerdienste, Johannesburgstasie, 2134, in verbinding te tree in verband met voordele wat uit die Nuwe Spoorweg- en Hawesuperannuasiefonds betaalbaar is.

E. KRÜGER, Hoofrekenmeester.

25-8

(8 Junie 1984)

KENNISGEWING 367 VAN 1984

DEPARTEMENT VAN GEMEENSKAPS-ONTWIKKELING

AGRÉMENT-RAAD VAN SUID-AFRIKA
(Goedkeuring van nuwe boustelsels en -produkte)

Kennis geskied hierby van 'n verandering van sertifikaathouer vir 'n agrément-sertifikaat, waarvan besonderhede in die Bylae hiervan verskyn. (Wysiging van Kennisgewing 223 van 1984, gedateer 30 Maart 1984.)

BYLAE

AGRÉMENT-RAAD VAN SUID-AFRIKA

Naam en nommer van sertifikaat.—No. 78/61, PHC-Montasieboustelsel.

Sertifikaathouer.—Verander van: Prefabricated Housing Corporation, Posbus 995, Germiston, 1400, na: Engineering Design and Construction Kie. Beperk, Posbus 82835, Southdale, 2135.

(8 Junie 1984)

NOTICE 359 OF 1984

DEPARTMENT OF JUSTICE

SOUTH AFRICAN LAW COMMISSION

The South African Law Commission is conducting an investigation into the Time Limits for the Institution of Actions against the State and would like to receive reasoned suggestions in writing for the development, improvement, modernisation or reform of this facet of the law.

A memorandum and draft bill which contain the Commission's tentative proposals and may serve as background information may be obtained free of charge from the Commission on request.

The Commission's offices are on the Eighth Floor, Nederduits Gereformeerde Kerk, Sinodale Sentrum, 228 Visagie Street, Pretoria. Correspondence should be addressed to—

The Secretary
South African Law Commission
Private Bag X668
0001 Pretoria
Telephone: (012) 26-1121.

(8 June 1984)

NOTICE 360 OF 1984

SOUTH AFRICAN TRANSPORT SERVICES

BENEFITS PAYABLE FROM THE NEW RAILWAYS AND HARBOURS SUPERANNUATION FUND.—THE LATE NICO STANDER

The late Mr Nico Stander, born on 20 December 1922, who was employed as a driver (RTS) by the South African Transport Services at Durban, died on 3 June 1981. His last known address was 82 Joubert Street, Parow Vallei. In the event of him being survived by a widow she is requested to communicate with the Assistant General Manager (Finance), Pensions Section, P.O. Box 47, South African Transport Services, Johannesburg Station, 2134, before 15 June 1984 in connection with benefits payable from the New Railways and Harbours Superannuation Fund.

E. KRÜGER, Chief Accountant.

25-8

(8 June 1984)

NOTICE 367 OF 1984

DEPARTMENT OF COMMUNITY DEVELOPMENT

AGRÉMENT BOARD OF SOUTH AFRICA
(Approval of new building systems and products)

Notice is hereby given of a change of certificate holder for an agrément certificate, details of which appear in the Schedule hereto. (Amendment to Notice 223 of 1984, dated 30 March 1984.)

SCHEDULE

AGRÉMENT BOARD OF SOUTH AFRICA

Name and number of certificate.—No. 78/61, PHC Industrialised Building System.

Certificate holder.—Changed from: Prefabricated Housing, P.O. Box 995, Germiston, 1400, to: Engineering Design and Construction Co. Limited, P.O. Box 82835, Southdale, 2135.

(8 June 1984)

KENNISGEWING 361 VAN 1984—NOTICE 361 OF 1984

P.5.01

VOORLOPIGE OPGAWE VAN HANDELSTATISTIEK VAN DIE REPUBLIEK VAN SUID-AFRIKA VRYGESTEL DEUR DIE KOMMISSARIS
 VAN DOEANE EN AKSYNS
 PRELIMINARY STATEMENT OF TRADE STATISTICS OF THE REPUBLIC OF SOUTH AFRICA RELEASED BY THE COMMISSIONER FOR
 CUSTOMS AND EXCISE

Opmerking.—Die in- en uitvoersyfers wat in hierdie opgawe verskyn is grootliks aangepas om dit in ooreenstemming te bring met die vereistes wat gestel word vir die opstel van die betalingsbalans
Remark.—The import and export figures reflected in this statement have been adjusted largely to bring them into line with the requirements for the compilation of the balance of payments

TYDPERK: JANUARIE TOT APRIL 1984—PERIOD: JANUARY TO APRIL 1984

TABEL A: TOTALE IN MILJOENE RAND VOLGENS WÊRELDSTREKE EN SKEEPS- EN VLIEGTUIGVOORRADE
 TABLE A: TOTALS IN MILLIONS OF RAND ACCORDING TO WORLD ZONES AND SHIPS' AND AIRCRAFT STORES

Wêreldstreke—World zones	Invoere—Imports		Uitvoere—Exports	
	1984	1983	1984	1983
Afrika—Africa	150,4	76,1	255,6	265,3
Europa—Europe	2 836,8	1 970,5	1 863,1	2 085,6
Amerika—America	1 258,8	864,5	665,8	625,9
Asië—Asia	1 169,2	716,0	846,2	842,6
Oseanië—Oceania	57,9	53,9	61,0	34,4
Ander ongeklassifiseerde goedere en betalingsbalansaansuiweringe Other unclassified goods and balance of payments adjustments	1 198,2	1 061,9	3 524,3	3 126,0
Skeeps-/vliegtuigvoorraad—Ships'/Aircraft stores	—	—	9,9	8,7
Groototaal—Grand total	6 671,3	4 742,9	7 225,9	6 988,5

TABEL B: TOTALE IN MILJOEN RAND VOLGENS AFDELINGS VAN DIE CCCN
 TABLE B: TOTALS IN MILLION RAND ACCORDING TO SECTIONS OF THE CCCN

Afdelings—Sections	Invoere—Imports		Uitvoere—Exports	
	1984	1983	1984	1983
I. Lewende diere; dierlike produkte Live animals; animal products	29,2	21,7	75,4	82,6
II. Plantaardige produkte Vegetable products	320,2	74,5	167,3	343,2
III. Dierlike en plantaardige vette en olies en splitsprodukte daarvan; voorbereide spysvette; dierlike en plantaardige wasse Animal and vegetable fats and oils and their cleavage products; prepared edible fats; animal and vegetable waxes	48,7	29,2	9,6	10,3
IV. Voorbereide voedsel; drank, spiritus en asyn; tabak Prepared foodstuffs; beverages, spirits and vinegar; tobacco	131,2	92,8	111,1	144,9
V. Minerale produkte Mineral products	83,9	54,1	842,3	602,0
VI. Produkte van die chemiese en verwante nywerhede Products of the chemical and allied industries	491,8	378,1	187,6	120,4
VII. Kunsharse en -plastiekstowwe, sellulose-esters en -eters, en artikels daarvan; rubber, sintetiese rubber, faktis, en artikels daarvan Artificial resins and plastic materials, cellulose esters and ethers, and articles thereof; rubber, synthetic rubber, factice, and articles thereof	228,7	139,6	24,4	25,0
VIII. Ongelooide huide en velle, leer, pelsvelle en artikels daarvan; saal- en ruimakersware; reisartikels, handsakke en dergelike houers; artikels van derm (uitgesonderd sywurmsnaar) Raw hides and skins, leather, furskins and articles thereof; saddlery and harness; travel goods, handbags and the like; articles of gut (other than silk-worm gut)	24,1	12,6	50,3	34,8
IX. Hout en artikels van hout; houtskool; kurk en artikels van kurk; fabrikate van strooi, van esparto en van ander vlegwerkstowwe; mandjiewerk en vlegwerk Wood and articles of wood; wood charcoal; cork and articles of cork; manufac- tures of straw, of esparto and of other plaiting materials; basketware and wickerwork	40,9	33,5	15,4	15,3
X. Stowwe vir die vervaardiging van papier; papier en papierbord en artikels daar- van Paper-making material; paper and paperboard and articles thereof	193,1	133,7	65,2	73,5

Afdelings—Sections	Invoere—Imports		Uitvoere—Exports	
	1984	1983	1984	1983
XI. Tekstiele en tekstielartikels Textiles and textile articles	334,3	195,9	235,8	169,3
XII. Skoetsel, hoofdeksels, sambrele, sonsambrele, swepe, ryswepe en onderdele daarvan; bereide vere en artikels daarvan gemaak; kunshloem; artikels van menschaar; waaiers Footwear, headgear, umbrellas, sunshades, whips, riding-crops and parts thereof; prepared feathers and articles made therewith; artificial flowers; articles of human hair; fans.....	34,8	17,3	2,2	1,9
XIII. Artikels van klip, van gips, van sement, van asbes, van mika en van dergelike stowwe; keramiese produkte; glas en glasware Articles of stone, of plaster, of cement, of asbestos, of mica and of similar materials; ceramic products; glass and glassware.....	81,8	48,0	12,2	11,3
XIV. Pêrels, edel- en halfedelstene, edelmetale, gewalste edelmetale, en artikels daarvan; nagmaakte juweliersware; muntstukke Pearls, precious and semi-precious stones, precious metals, rolled precious metals, and articles thereof; imitation jewellery; coin	46,0	24,9	669,7	1 137,0
XV. Onedelmetale en artikels daarvan Base metals and articles of base metal	321,3	227,9	696,8	578,4
XVI. Masjinerie en meganiese toestelle; elektriese toerusting; onderdele daarvan Machinery and mechanical appliances; electrical equipment; parts thereof.....	1 896,8	1 344,5	71,7	70,5
XVII. Voertuie, vliegtuie en onderdele daarvan; vaartuie en sekere verwante vervoer-toerusting Vehicles, aircraft, and parts thereof; vessels and certain associated transport equipment.....	782,6	611,6	62,5	64,9
XVIII. Optiese, fotografiese, kinematografiese, meet-, kontrole-, presisie-, mediese en chirurgiese instrumente en apparaat; uurwerke en horlosies; musiekinstrumente; televisiebeeld- en klankopnemers en -weergewers, magneties; onderdele daarvan Optical, photographic, cinematographic, measuring, checking, precision, medical and surgical instruments and apparatus; clocks and watches; musical instruments, television image and sound recorders and reproducers; parts thereof.....	290,4	181,4	9,4	9,8
XX. Diverse vervaardigde artikels Miscellaneous manufactured articles.....	55,0	33,4	5,1	6,7
XXI. Kunswerke, versamelaarsstukke en antieke	16,0	4,6	2,1	1,1
Ander ongeklassifiseerde goedere en betalingsbalansaansuiweringe Other unclassified goods and balance of payments adjustments.....	1 220,5	1 083,6	3 909,8	3 485,6
Groototaal—Grand total	6 671,3	4 742,9	7 225,9	6 988,5

(8 Junie 1984)/(8 June 1984)

KENNISGEWING 362 VAN 1984

DEPARTEMENT VAN GEMEENSKAPSONTWIKKELING

AGRÉMENT-RAAD VAN SUID-AFRIKA
(Goedkeuring van nuwe boustelsels en -produkte)

Kennis geskied hierby dat die Agrément-raad van Suid-Afrika 'n agrément-sertifikaat, waarvan besonderhede in die Bylae hiervan verskyn, met ingang van 29 Maart 1984 uitgereik het.

BYLAE

AGRÉMENT-RAAD VAN SUID-AFRIKA

Sertifikaat 84/114 (Hernuwing)

Naam van produk.—Ribframe.

Vervaardig deur.—Murray & Roberts Buildings (Transvaal) (Edms.) Bpk.

Kort beskrywing.—Hierdie sertifikaat vervang Sertifikaat 77/43 en het betrekking op die Ribframe-boustelsel vir die oprigting van enkelverdieping- en veelverdiepinggeboue

NOTICE 362 OF 1984

DEPARTMENT OF COMMUNITY DEVELOPMENT

AGRÉMENT BOARD OF SOUTH AFRICA
(Approval of new building systems and products)

Notice is hereby given that the Agrément Board of South Africa has issued an agrément certificate, details of which appear in the Schedule hereto, with effect from 29 March 1984.

SCHEDULE

AGRÉMENT BOARD OF SOUTH AFRICA

Certificate 84/114 (Renewal)

Name of product.—Ribframe.

Manufactured by.—Murray & Roberts Buildings (Transvaal) (Pty) Ltd.

Brief description.—This certificate replaces Certificate 77/43 and relates to the Ribframe building system for the erection of single storey and multistorey (up to eight stories

(tot en met agt verdiepings hoog) vir gebruik as nie-residensiële skole, kantore, hostelle en nywerheidsgeboue in alle dele van Suid-Afrika en Suidwes-Afrika. Ribframegeboue maak gebruik van 'n betonraamstruktuur met nie-lasdraende, voorgegiete buite- en binnemuurpanele. Voorgegiete betonbalke, trappe, vloere en dakpanele word gebruik en die raamstruktuur word op konvensionele fondamente opgerig. Die buitemuurpanele het 'n kern van sandlose beton. Binnemuurpanele het of 'n sandlose betonkern of hulle is van 'n digte beton en het verskillende diktes.

Afskrifte van die sertifikaat, wat gedetailleerde spesifikasies en tekeninge bevat, is verkrygbaar van die Algemene Bestuurder, Agrément-raad van Suid-Afrika, Posbus 395, Pretoria, 0001, teen 'n koste van R5 per eksemplaar (vir elke amptelike taal).

(8 Junie 1984)

KENNISGEWING 363 VAN 1984

DEPARTEMENT VAN GEMEENSKAPS-ONTWIKKELING

AGRÉMENT-RAAD VAN SUID-AFRIKA (Goedkeuring van nuwe boustelsels en -produkte)

Kennis geskied hierby dat die Agrément-raad van Suid-Afrika 'n agrément-sertifikaat waarvan besonderhede in die Bylae hiervan verskyn, met ingang van 26 April 1984 uitgereik het.

BYLAE

AGRÉMENT-RAAD VAN SUID-AFRIKA

Sertifikaat 84/115 (Hernuwing)

Naam van produk.—Rjwall.

Vervaardig deur.—Murray & Roberts Buildings (Transvaal) (Edms.) Bpk.

Kort beskrywing.—Hierdie sertifikaat vervang Sertifikaat 77/44 en het betrekking op die Ribwall-boustelsel vir die oprigting van enkelverdieping- en veelverdiepinggeboue (tot en met agt verdiepings hoog) vir gebruik as woonstelle, hostelle en kantore in alle dele van Suid-Afrika en Suidwes-Afrika. Ribwall-geboue bestaan uit verdiepinghoë lasdraende voorgegiete betondwarsmure en gewelmure, voorgegiete gewapende betonvloerblaaie en nie-lasdraende voorgegiete betonfasade- en binnemure. Fasadepanale het 'n sandlose betonkern. Binnemuurpanele het of 'n sandlose betonkern of hulle is van digte beton en het verskillende diktes.

Fondamente word ontwerp om by individuele terreintoe-stande te pas. Dakke is of gevlaakte en waterdig gemaakte betonblaaie, of houtkappe bedek met konvensionele dakmateriaal. Dienste is gewoonlik konvensioneel.

Afskrifte van die sertifikaat, wat gedetailleerde spesifikasies en tekeninge bevat, is verkrygbaar van die Algemene Bestuurder, Agrément-raad van Suid-Afrika, Posbus 395, Pretoria, 0001, teen 'n koste van R5 per eksemplaar (vir elke amptelike taal).

(8 Junie 1984)

KENNISGEWING 364 VAN 1984

DEPARTEMENT VAN GEMEENSKAPS-ONTWIKKELING

AGRÉMENT-RAAD VAN SUID-AFRIKA (Goedkeuring van nuwe boustelsels en -produkte)

Kennis geskied hierby dat die Agrément-raad van Suid-Afrika 'n agrément-sertifikaat waarvan besonderhede in die Bylae hiervan verskyn, met ingang van 29 Maart 1984 uitgereik het.

high) non-residential school buildings, offices, hostels and industrial buildings in all areas of South Africa and South-West Africa. Ribframe buildings consist of framed reinforced concrete structures with non-loadbearing, precast concrete external and internal wall panels. Precast concrete beams, stairs, floors and roof panels are used and the framed structure is erected on conventional foundations. The external wall panels have a core of no-fines concrete. Internal wall panels either have a no-fines concrete core or are of dense concrete and vary in thickness.

This certificate contains detailed specifications and drawings and copies are obtainable from the General Manager, Agrément Board of South Africa, P.O. Box 395, Pretoria, 0001, at a cost of R5 per copy (for each official language).

(8 June 1984)

NOTICE 363 OF 1984

DEPARTMENT OF COMMUNITY DEVELOPMENT

AGRÉMENT BOARD OF SOUTH AFRICA (Approval of new building systems and products)

Notice is hereby given that the Agrément Board of South Africa has issued an agrément certificate, details of which appear in the Schedule hereto, with effect from 26 April 1984.

SCHEDULE

AGRÉMENT BOARD OF SOUTH AFRICA

Certificate 84/115 (Renewal)

Name of product.—Ribwall.

Manufactured by.—Murray & Roberts Buildings (Transvaal) (Pty) Limited.

Brief description.—This certificate replaces Certificate 77/44 and relates to Ribwall building system for the erection of single storey and multistorey (up to eight storeys high) flats, hostels and offices in all areas of South Africa and South-West Africa. Ribwall buildings consist of storey-high loadbearing precast concrete crosswalls and gable walls, precast reinforced concrete floor slabs and non-loadbearing precast concrete facade and internal walls. Facade panels have a no-fines concrete core. Internal wall panels either have a no-fines concrete core or they are of dense concrete and vary in thickness.

Foundations are designed to suit individual site conditions. Roofs are either screeded and waterproofed concrete slabs, or timber trusses covered with conventional roofing materials. Services are generally conventional.

This certificate contains detailed specifications and drawings and copies are obtainable from the General Manager, Agrément Board of South Africa, P.O. Box 395, Pretoria, 0001, at a cost of R5 per copy (for each official language).

(8 June 1984)

NOTICE 364 OF 1984

DEPARTMENT OF COMMUNITY DEVELOPMENT

AGRÉMENT BOARD OF SOUTH AFRICA (Approval of new building systems and products)

Notice is hereby given that the Agrément Board of South Africa has issued an agrément certificate, details of which appear in the Schedule hereto, with effect from 29 March 1984.

BYLAE

AGRÉMENT-RAAD VAN SUID-AFRIKA

Sertifikaat 84/116 (Hernuwing)

Naam van produk.—Inseal 3507.*Vervaardig deur.*—Kohler Sellotape-Produkte.

Kort beskrywing.—Hierdie sertifikaat vervang Sertifikaat 80/82 en het betrekking op Inseal 3507 (voorheen bekend as Inseal 5375). Inseal 3507 is 'n strookafdigter wat by beglasing en invulpaneel soos bladmetaal, vesementprodukte (asbesvesels) ens., in vensters met ruitkraallyste wat 'n positiewe drukrag op die afdigtingstrook kan uitoefen en wat 'n toestand van druk teen die glas en invulpaneel kan handhaaf, gebruik kan word.

Afskrifte van die sertifikaat, wat gedetailleerde spesifikasies en tekeninge bevat, is verkrygbaar van die Algemene Bestuurder, Agrément-raad van Suid-Afrika, Posbus 395, Pretoria, 0001, teen 'n koste van R5 per eksemplaar (vir elke amptelike taal).

(8 Junie 1984)

KENNISGEWING 365 VAN 1984

DEPARTEMENT VAN GEMEENSKAPS-ONTWIKKELING

AGRÉMENT-RAAD VAN SUID-AFRIKA
(Goedkeuring van nuwe boustelsels en -produkte)

Kennis geskied hierby dat die Agrément-raad van Suid-Afrika 'n agrément-sertifikaat, waarvan besonderhede in die Bylae hiervan verskyn, met ingang van 26 April 1984 uitgereik het.

BYLAE

AGRÉMENT-RAAD VAN SUID-AFRIKA

Sertifikaat 84/117 (Hernuwing)

Naam van produk.—National and Overseas se Fabriekvervaardigde Geboue.*Vervaardig deur.*—National and Overseas Distributing Corporation.

Kort beskrywing.—Hierdie sertifikaat vervang Sertifikaat 78/60 en het betrekking op National and Overseas se Fabriekvervaardigde Geboue vir die oprigting van enkelverdieping losstaande huise en hulle gepaardgaande buitegeboue, 'oop-vinger'-tipe skoolgeboue (nie-residensieel), kantoorgeboue en institusionele geboue oral in Suid-Afrika en Suidwes-Afrika met uitsondering van die kusgebiede van Suidwes-Afrika. Hierdie stelsel maak gebruik van 'n lasdraende staalraamwerk, wat volgens 'n modulêre stelsel opgerig word. Die raamwerk word aan die buitekant beklee met VS-plate en aan die binnekant met of VS-plate of gipsbord om spoumure te vorm. Buitemure en sekere binnemure word met 'n glasveselkometers geïsoleer.

Fondamente, betonbeddinglae, dienste en dakbedekkings is konvensioneel.

Afskrifte van die sertifikaat, wat gedetailleerde spesifikasies en tekeninge bevat, is verkrygbaar van die Algemene Bestuurder, Agrément-raad van Suid-Afrika, Posbus 395, Pretoria, 0001, teen 'n koste van R5 per eksemplaar (vir elke amptelike taal).

(8 Junie 1984)

SCHEDULE

AGRÉMENT BOARD OF SOUTH AFRICA

Certificate 84/116 (Renewal)

Name of product.—Inseal 3507.*Manufactured by.*—Kohler Sellotape Products.

Brief description.—This certificate replaces Certificate 80/82 and relates to Inseal 3507 (previously known as Inseal 5375). Inseal 3507 is a strip sealant which can be used in glazing work and for infill panels, such as sheet metal, fibre cement products (asbestos fibres), etc., in windows which are fitted with glazing beads capable of exerting a positive compressive force on the sealing strip and retaining it in a state of compression against the glass or infill panel.

This certificate contains detailed specifications and drawings and copies are obtainable from the General Manager, Agrément Board of South Africa, P.O. Box 395, Pretoria, 0001, at a cost of R5 per copy (for each official language).

(8 June 1984)

NOTICE 365 OF 1984

DEPARTMENT OF COMMUNITY DEVELOPMENT

AGRÉMENT BOARD OF SOUTH AFRICA
(Approval of new building systems and products)

Notice is hereby given that the Agrément Board of South Africa has issued an agrément certificate, details of which appear in the Schedule hereto, with effect from 26 April 1984.

SCHEDULE

AGRÉMENT BOARD OF SOUTH AFRICA

Certificate 84/117 (Renewal)

Name of product.—National and Overseas Factory Built Buildings.*Manufactured by.*—National and Overseas Distributing Corporation.

Brief description.—This certificate replaces Certificate 78/60 and relates to National and Overseas Factory Built Buildings for the erection of single storey detached dwellings and related outbuildings, open finger type non-residential school buildings, office buildings and institutional buildings in all areas of South Africa and South-West Africa except the coastal areas of South-West Africa. This system comprises a loadbearing steel framework, erected on a modular grid. The framework is clad externally with FC sheets and internally with either FC sheets or gypsum plasterboard to form hollow walls. External walls and certain internal walls are insulated with glass-fibre quilt.

Foundations, concrete surface beds, services and roof coverings are conventional.

This certificate contains detailed specifications and drawings and copies are obtainable from the General Manager, Agrément Board of South Africa, P.O. Box 395, Pretoria, 0001, at a cost of R5 per copy (for each official language).

(8 June 1984)

KENNISGEWING 366 VAN 1984**DEPARTEMENT VAN GEMEENSKAPS-
ONTWIKKELING****AGRÉMENT-RAAD VAN SUID-AFRIKA**
(Goedkeuring van nuwe boustelsels en -produkte)

Kennis geskied hierby dat aansoeke om agrément-sertifisering, wat in die Bylae hiervan vermeld word, deur die Agrément-raad van Suid-Afrika, tydens sy vergadering gehou op 26 April 1984 aanvaar is.

BYLAE**AGRÉMENT-RAAD VAN SUID-AFRIKA**

(1) *Aansoeker.*—Fabricated Steel Manufacturing Mpy. (Edms.) Bpk.

Onderwerp.—FSM-Boustelsel.

Gebruik.—Boustelsel vir die oprigting van enkelverdiepinghuise met gepaardgaande buitegeboue, skole en hotele, kantore en nywerheidsgeboue in alle dele van Suid-Afrika en Suidwes-Afrika.

(2) *Aansoeker.*—Tarmac Roadstone S.A. (Edms.) Bpk.

Onderwerp.—Salviacim-proses vir Vloere in Nywerheidsgeboue.

Gebruik.—'n Proses vir die voorsiening van vloere vir pakhuse en fabriek waar geselekteerde produkte vervaardig en geberg word.

(3) *Aansoeker.*—D.A. Grant Building Contractors.

Onderwerp.—Grant GVS-Boustelsel.

Gebruik.—Boustelsel vir die oprigting van enkelverdiepinghuise (losstaande en skakelhuise) met hulle gepaardgaande buitegeboue, nie-residensiële skoolgeboue van die "oop vinger"-tipe, polisieostasies, hospitale en kantore in alle dele van Suid-Afrika.

(4) *Aansoeker.*—Happy Doors Construction Mpy. (Edms.) Bpk.

Onderwerp.—Hyper Simplicity A-Raam-Boustelsel.

Gebruik.—Boustelsel vir die oprigting van enkelverdieping- en dubbelverdiepinghuise en -ryhuise met hulle gepaardgaande buitegeboue in alle dele van Suid-Afrika en Suidwes-Afrika.

(5) *Aansoeker.*—CI Parkhomes.

Onderwerp.—Kwikspan-Boustelsel.

Gebruik.—Boustelsel vir die oprigting van enkelverdiepinggeboue vir nie-residensiële gebruik, bv. kantore, klas-kamers, eetsale en ontspanningsale, in alle dele van Suid-Afrika en Suidwes-Afrika.

(8 Junie 1984)

NOTICE 366 OF 1984**DEPARTMENT OF COMMUNITY
DEVELOPMENT****AGRÉMENT BOARD OF SOUTH AFRICA**
(Approval of new building systems and products)

Notice is hereby given that applications for agrément certification, listed in the Schedule hereto, have been accepted by the Agrément Board of South Africa at its meeting held on 26 April 1984.

SCHEDULE**AGRÉMENT BOARD OF SOUTH AFRICA**

(1) *Applicant.*—Fabricated Steel Manufacturing Co. (Pty) Ltd.

Subject.—FSM Building System.

Use.—Building system for the construction of single storey houses with related outbuildings, schools and hostels, offices and industrial buildings in all areas of South Africa and South-West Africa.

(2) *Applicant.*—Tarmac Roadstone SA (Pty) Ltd.

Subject.—Salviacim Process for Industrial Flooring.

Use.—Process for providing flooring in warehouses and factories where selected products are manufactured and stored.

(3) *Applicant.*—D.A. Grant Building Contractors.

Subject.—Grant GRC Building System.

Use.—Building system for the construction of single storey detached and semi-detached houses and their related outbuildings, non-residential school buildings of the "open-finger" type, police stations, hospitals and offices in all areas of South Africa.

(4) *Applicant.*—Happy Doors Construction Co. (Pty) Ltd.

Subject.—Hyper Simplicity A-Frame Building System.

Use.—Building system for the erection of single storey and double storey houses and row houses with their related outbuildings in all areas of South Africa and South-West Africa.

(5) *Applicant.*—CI Parkhomes.

Subject.—Kwikspan Building System.

Use.—Building system for the construction of single storey non-residential buildings, e.g. offices, classrooms, dining and recreational halls, in all areas of South Africa and South-West Africa.

(8 June 1984)

KENNISGEWING 368 VAN 1984**DEPARTEMENT VAN GEMEENSKAPS-
ONTWIKKELING****AGRÉMENT-RAAD VAN SUID-AFRIKA**
(Goedkeuring van nuwe boustelsels en -produkte)

Kennis geskied hierby dat die Agrément-raad van Suid-Afrika die geldigheidsduur van 'n sertifikaat, waarvan besonderhede in die Bylae hiervan verskyn, met ingang van 13 April 1984 verleng het.

BYLAE**AGRÉMENT-RAAD VAN SUID-AFRIKA**

Sertifikaat 76/30 (Voorlopig) (geldig tot 12 April 1984)

Naam van produk.—Wimpey-Sandlose Betonstelsel.

NOTICE 368 OF 1984**DEPARTMENT OF COMMUNITY
DEVELOPMENT****AGRÉMENT BOARD OF SOUTH AFRICA**
(Approval of new building systems and products)

Notice is hereby given that the Agrément Board of South Africa has extended the validity of a certificate, details of which appear in the Schedule hereto, with effect from 13 April 1984.

SCHEDULE**AGRÉMENT BOARD OF SOUTH AFRICA**

Certificate 76/30 (Interim) (valid until 12 April 1984)

Name of product.—Wimpey No-Fines Concrete System.

Vervaardig deur.—George Wimpey & Co. (Southern Africa) (Pty) Ltd, Posbus 23272, Joubertpark, 2044.

Die geldigheidsduur van hierdie sertifikaat, wat by Kennisgewing 490 van 1976, gedateer 23 Julie 1976, uitgereik is, word vir 'n verdere tydperk van hoogstens ses maande verleng.

(8 Junie 1984)

KENNISGEWING 369 VAN 1984

DEPARTEMENT VAN GEMEENSKAPS- ONTWIKKELING

AGRÉMENT-RAAD VAN SUID-AFRIKA (Goedkeuring van nuwe boustelsels en -produkte)

Kennis geskied hierby dat die Agrément-raad van Suid-Afrika die geldigheidsduur van 'n sertifikaat, waarvan besonderhede in onderstaande Bylae verskyn, met ingang van 24 Mei 1984 verleng het.

BYLAE

AGRÉMENT-RAAD VAN SUID-AFRIKA

Sertifikaat 78/55 (geldig tot 23 Mei 1984)

Naam van produk.—Conmac.

Vervaardig deur.—McCarthy Contractors (Edms.) Bpk., Posbus 1281, Kaapstad, 8000.

Die geldigheidsduur van hierdie sertifikaat, wat by Kennisgewing 796 van 1978, gedateer 6 Oktober 1978, uitgereik is, word vir 'n verdere tydperk van hoogstens ses maande verleng.

(8 Junie 1984)

KENNISGEWING 370 VAN 1984

DEPARTEMENT VAN GEMEENSKAPS- ONTWIKKELING

AGRÉMENT-RAAD VAN SUID-AFRIKA (Goedkeuring van nuwe boustelsels en -produkte)

Kennis geskied hierby dat die Agrément-raad van Suid-Afrika die geldigheidsduur van 'n sertifikaat, waarvan besonderhede in die Bylae hiervan verskyn, met ingang van 30 Mei 1984 verleng het.

BLYAE

AGRÉMENT-RAAD VAN SUID-AFRIKA

Sertifikaat 78/63 (geldig tot 29 Mei 1984)

Naam van produk.—Imprefed Montasie Veelverdieping-boustelsel.

Vervaardig deur.—Imprefed (Edms.) Bpk., Posbus 31667, Braamfontein, 2017.

Die geldigheidsduur van hierdie sertifikaat, wat by Kennisgewing 465 van 1979, gedateer 15 Junie 1979, uitgereik is, word vir 'n verdere tydperk van hoogstens ses maande verleng.

(8 Junie 1984)

KENNISGEWING 371 VAN 1984

DEPARTEMENT VAN GEMEENSKAPS- ONTWIKKELING

AGRÉMENT-RAAD VAN SUID-AFRIKA (Goedkeuring van nuwe boustelsels en -produkte)

Kennis geskied hierby dat die Agrément-raad van Suid-Afrika die geldigheidsduur van 'n sertifikaat, waarvan besonderhede in die Bylae hiervan verskyn, met ingang van 2 Mei 1984 verleng het.

Manufactured by.—George Wimpey & Co. (Southern Africa) (Pty) Ltd, P.O. Box 23272, Joubertpark, 2044.

The validity of this certificate, which was issued under Notice 490 of 1976, dated 23 July 1976, is further extended for a period not exceeding six months.

(8 June 1984)

NOTICE 369 OF 1984

DEPARTMENT OF COMMUNITY DEVELOPMENT

AGRÉMENT BOARD OF SOUTH AFRICA (Approval of new building systems and products)

Notice is hereby given that the Agrément Board of South Africa has extended the validity of a certificate, details of which appear in the Schedule hereto, with effect from 24 May 1984.

SCHEDULE

AGRÉMENT BOARD OF SOUTH AFRICA

Certificate 78/55 (valid until 23 May 1984)

Name of product.—Conmac.

Manufactured by.—McCarthy Contractors (Pty) Ltd, P.O. Box 1281, Cape Town, 8000.

The validity of this certificate, which was issued under Notice 796 of 1978, dated 6 October 1978, is further extended for a period not exceeding six months.

(8 June 1984)

NOTICE 370 OF 1984

DEPARTMENT OF COMMUNITY DEVELOPMENT

AGRÉMENT BOARD OF SOUTH AFRICA (Approval of new building systems and products)

Notice is hereby given that the Agrément Board of South Africa has extended the validity of a certificate, details of which appear in the Schedule hereto, with effect from 30 May 1984.

SCHEDULE

AGRÉMENT BOARD OF SOUTH AFRICA

Certificate 78/63 (valid until 29 May 1984)

Name of product.—Imprefed Industrailized Multistorey Building System.

Manufactured by.—Imprefed (Pty) Ltd, P.O. Box 31667, Braamfontein, 2017.

The validity of this certificate, which was issued under Notice 465 of 1979, dated 15 June 1979, is further extended for a period not exceeding six months.

(8 June 1984)

NOTICE 371 OF 1984

DEPARTMENT OF COMMUNITY DEVELOPMENT

AGRÉMENT BOARD OF SOUTH AFRICA (Approval of new building systems and products)

Notice is hereby given that the Agrément Board of South Africa has extended the validity of a certificate, details of which appear in the Schedule hereto, with effect from 2 May 1984.

BYLAE

AGRÉMENT-RAAD VAN SUID-AFRIKA

Sertifikaat 79/74 (geldig tot 1 Mei 1984)

Naam van produk.—Gypsum Industries se Rhinoshield-boustelstel.

Vervaardig deur.—Gypsum Industries Beperk, Posbus 75012, Garden View, 2047.

Die geldigheidsduur van hierdie sertifikaat, wat by Kennisgewing 18 van 1980, gedateer 4 Januarie 1980, uitgereik is, word vir 'n verdere tydperk van hoogstens ses maande verleng.

(8 Junie 1984)

KENNISGEWING 372 VAN 1984

DEPARTEMENT VAN GEMEENSKAPS-ONTWIKKELING

AGRÉMENT-RAAD VAN SUID-AFRIKA
(Goedkeuring van nuwe boustelsels en -produkte)

Kennis geskied hierby dat die Agrément-raad van Suid-Afrika die geldigheidsduur van 'n sertifikaat, waarvan besonderhede in die Bylae hiervan verskyn, met ingang van 2 Mei 1984 verleng het.

BYLAE

AGRÉMENT-RAAD VAN SUID-AFRIKA

Sertifikaat 79/76 (geldig tot 1 Mei 1984)

Naam van produk.—Vertrou Bou-Wadekor-Montasieboubaksteenvoorwerk-boustelsel.

Vervaardig deur.—Wadekor Konstruksie (Edms.) Bpk., Posbus 49080, Rosettenville, 2130.

Die geldigheidsduur van hierdie sertifikaat, wat by Kennisgewing 20 van 1980, gedateer 4 Januarie 1980, uitgereik is, word vir 'n verdere tydperk van hoogstens ses maande verleng.

(8 Junie 1984)

KENNISGEWING 373 VAN 1984

DEPARTEMENT VAN GEMEENSKAPS-ONTWIKKELING

AGRÉMENT-RAAD VAN SUID-AFRIKA
(Goedkeuring van nuwe boustelsels en -produkte)

Kennis geskied hierby dat die Agrément-raad van Suid-Afrika die geldigheidsduur van 'n sertifikaat, waarvan besonderhede in die Bylae hiervan verskyn, met ingang van 29 Mei 1984 verleng het.

BYLAE

AGRÉMENT-RAAD VAN SUID-AFRIKA

Sertifikaat 80/80 (geldig tot 28 Mei 1984)

Naam van produk.—Kwikot-Sonwaterverwarmingstelsel.

Vervaardig deur.—Kwikot Beperk, Posbus 389, Benoni, 1500.

Die geldigheidsduur van hierdie sertifikaat, wat by Kennisgewing 466 van 1980, gedateer 4 Julie 1980, uitgereik is, word vir 'n verdere tydperk van hoogstens ses maande verleng.

(8 Junie 1984)

SCHEDULE

AGRÉMENT BOARD OF SOUTH AFRICA

Certificate 79/74 (valid until 1 May 1984)

Name of product.—Gypsum Industries Rhinoshield Building System.

Manufactured by.—Gypsum Industries Limited, P.O. Box 75012, Garden View, 2047.

The validity of this certificate, which was issued under Notice 18 of 1980, dated 4 January 1980, is further extended for a period not exceeding six months.

(8 June 1984)

NOTICE 372 OF 1984

DEPARTMENT OF COMMUNITY DEVELOPMENT

AGRÉMENT BOARD OF SOUTH AFRICA
(Approval of new building systems and products)

Notice is hereby given that the Agrément Board of South Africa has extended the validity of a certificate, details of which appear in the Schedule hereto, with effect from 2 May 1984.

SCHEDULE

AGRÉMENT BOARD OF SOUTH AFRICA

Certificate 79/76 (valid until 1 May 1984)

Name of product.—Vertrou Bou-Wadekor Industrialised Brick Veneer Building System.

Manufactured by.—Wadekor Konstruksie (Pty) Ltd, P.O. Box 49080, Rosettenville, 2130.

The validity of this certificate, which was issued under Notice 20 of 1980, dated 4 January 1980, is further extended for a period not exceeding six months.

(8 June 1984)

NOTICE 373 OF 1984

DEPARTMENT OF COMMUNITY DEVELOPMENT

AGRÉMENT BOARD OF SOUTH AFRICA
(Approval of new building systems and products)

Notice is hereby given that the Agrément Board of South Africa has extended the validity of a certificate, details of which appear in the Schedule hereto, with effect from 29 May 1984.

SCHEDULE

AGRÉMENT BOARD OF SOUTH AFRICA

Certificate 80/80 (valid until 28 May 1984)

Name of product.—Kwikot Solar Water Heating System.

Manufactured by.—Kwikot Limited, P.O. Box 389, Benoni, 1500.

The validity of this certificate, which was issued under Notice 466 of 1980, dated 4 July 1980, is further extended for a period not exceeding six months.

(8 June 1984)

KENNISGEWING 374 VAN 1984

**DEPARTEMENT VAN GEMEENSKAPS-
ONTWIKKELING**

AGRÉMENT-RAAD VAN SUID-AFRIKA
(Goedkeuring van nuwe boustelsels en -produkte)

Kennis geskied hierby dat die Agrément-raad van Suid-Afrika die geldigheidsduur van 'n sertifikaat, waarvan besonderhede in die Bylae hiervan verskyn, met ingang van 27 Maart 1984 verleng het.

BYLAE

AGRÉMENT-RAAD VAN SUID-AFRIKA

Sertifikaat 80/81 (geldig tot 26 Maart 1984)

Naam van produk.—Cavcon se Modulêre Boustelsel.

Vervaardig deur.—William Jürgens & Sons Incorporated, Posbus 328, Uitenhage, 6230.

Die geldigheidsduur van hierdie sertifikaat, wat by Kennisgewing 411 van 1980, gedateer 20 Junie 1980 uitgereik is, word vir 'n verdere tydperk van hoogstens ses maande verleng.

(8 Junie 1984)

NOTICE 374 OF 1984

**DEPARTMENT OF COMMUNITY
DEVELOPMENT**

AGRÉMENT BOARD OF SOUTH AFRICA
(Approval of new building systems and products)

Notice is hereby given that the Agrément Board of South Africa has extended the validity of a certificate, details of which appear in the Schedule hereto, with effect from 27 March 1984.

SCHEDULE

AGRÉMENT BOARD OF SOUTH AFRICA

Certificate 80/81 (valid until 26 March 1984)

Name of product.—Cavcon Modular Building System.

Manufactured by.—William Jürgens & Sons Incorporated, P.O. Box 328, Uitenhage, 6230.

The validity of this certificate, which was issued under Notice 411 of 1980, dated 20 June 1980, is further extended for a period not exceeding six months.

(8 June 1984)

KENNISGEWING 375 VAN 1984

**DEPARTEMENT VAN GEMEENSKAPS-
ONTWIKKELING**

AGRÉMENT-RAAD VAN SUID-AFRIKA
(Goedkeuring van nuwe boustelsels en -produkte)

Kennis geskied hierby dat die Agrément-raad van Suid-Afrika die geldigheidsduur van 'n sertifikaat, waarvan besonderhede in die Bylae hiervan verskyn, met ingang van 6 Mei 1984 verleng het.

BYLAE

AGRÉMENT-RAAD VAN SUID-AFRIKA

Sertifikaat 80/84 (geldig tot 5 Mei 1984)

Naam van produk.—LTA Sandlose Betonstelsel.

Vervaardig deur.—LTA Construction Ltd, Posbus 690, Kempton Park, 1620.

Die geldigheidsduur van hierdie sertifikaat, wat by Kennisgewing 407 van 1981, gedateer 5 Junie 1981, uitgereik is, word vir 'n verdere tydperk van hoogstens ses maande verleng.

(8 Junie 1984)

NOTICE 375 OF 1984

**DEPARTMENT OF COMMUNITY
DEVELOPMENT**

AGRÉMENT BOARD OF SOUTH AFRICA
(Approval of new building systems and products)

Notice is hereby given that the Agrément Board of South Africa has extended the validity of a certificate, details of which appear in the Schedule hereto, with effect from 6 May 1984.

SCHEDULE

AGRÉMENT BOARD OF SOUTH AFRICA

Certificate 80/84 (valid until 5 May 1984)

Name of product.—LTA No-Fines Concrete System.

Manufactured by.—LTA Construction Ltd, P.O. Box 690, Kempton Park, 1620.

The validity of this certificate, which was issued under Notice 407 of 1981, dated 5 June 1981, is further extended for a period not exceeding six months.

(8 June 1984)

KENNISGEWING 376 VAN 1984

**DEPARTEMENT VAN GEMEENSKAPS-
ONTWIKKELING**

AGRÉMENT-RAAD VAN SUID-AFRIKA
(Goedkeuring van nuwe boustelsels en -produkte)

Kennis geskied hierby dat die Agrément-raad van Suid-Afrika die geldigheidsduur van 'n sertifikaat, waarvan besonderhede in die Bylae hiervan verskyn, met ingang van 25 Maart 1984 verleng het.

BYLAE

AGRÉMENT-RAAD VAN SUID-AFRIKA

Sertifikaat 81/88 (geldig tot 24 Maart 1984)

Naam van produk.—LTA Rimon.

NOTICE 376 OF 1984

**DEPARTMENT OF COMMUNITY
DEVELOPMENT**

AGRÉMENT BOARD OF SOUTH AFRICA
(Approval of new building systems and products)

Notice is hereby given that the Agrément Board of South Africa has extended the validity of a certificate, details of which appear in the Schedule hereto, with effect from 25 March 1984.

SCHEDULE

AGRÉMENT BOARD OF SOUTH AFRICA

Certificate 81/88 (valid until 24 March 1984)

Name of product.—LTA Rimon.

Vervaardig deur.—Conforce (Edms.) Bpk., Posbus 82510, Southdale, 2135.

Die geldigheidsduur van hierdie sertifikaat, wat by Kennisgewing 411 van 1981, gedateer 5 Junie 1981, uitgereik is, word vir 'n verdere tydperk van hoogstens ses maande verleng.

(8 Junie 1984)

KENNISGEWING 377 VAN 1984

DEPARTEMENT VAN GEMEENSKAPS-ONTWIKKELING

AGRÉMENT-RAAD VAN SUID-AFRIKA (Goedkeuring van nuwe boustelsels en -produkte)

Kennis geskied hierby dat die Agrément-raad van Suid-Afrika 'n verandering aan 'n sertifikaathouer se lys van geregsitreeerde lisensiehouers wat sy gesertifiseerde produk mag vervaardig/monteer/aanwend/oprig soos omskryf en gespesifiseer in die toepaslike sertifikaat, geregistreer het, soos uiteengesit in die Bylae hiervan.

BYLAE

AGRÉMENT-RAAD VAN SUID-AFRIKA

Byvoegings

(1) *Sertifikaathouer.*—Gypsum Industries Beperk.

Nommer en titel van sertifikaat waarvoor lisensies uitgereik is.—No. 79/71, Gypsum Industries se Baksteenvoorwerkhuise.

Name en adresse van lisensiehouers:

(1) Shield Timber Frame Homes, Primariusstraat 9, Strand, 7140.

(2) Elgin Timbers, Posbus 16, Grabouw, 7160.

(3) A.S.H. Brick Veneer Builders, Baakensweg 28, Primrose Park, 7764.

(4) Structaframe (Edms.) Bpk., Posbus 7123, Dinwiddie, 1405.

(2) *Sertifikaathouer.*—Gypsum Industries Beperk.

Nommer en titel van sertifikaat waarvoor lisensie uitgereik is.—No. 79/74, Rhinoshield-boustelsel.

Naam en adres van lisensiehouer.—Cape Modular Buildings (Edms.) Bpk., Posbus 413, Parow, 7500.

(8 Junie 1984)

KENNISGEWING 357 VAN 1984

DEPARTEMENT VAN SAMEWERKING EN ONTWIKKELING

SUIDELIKE EGSKEIDINGSHOF.—SITTINGS

Die Direkteur-generaal van Samewerking en Ontwikkeling het kragtens artikel 13 (6) van die Swart Administrasie Wet, 1927 (Wet 38 van 1927), en artikel 10 (4) van die Swart Administrasie Wet, 1927, Wysigingswet, 1929 (Wet 9 van 1929), bepaal dat sittings van die Suidelike Egskeidingshof om 09h00, of so spoedig daarna as wat gerieflik is, op onderstaande plekke en datums 'n aanvang sal neem:

Kimberley: Maandag, 2 Julie 1984.

Kroonstad: Vrydag, 6 Julie 1984.

Bloemfontein: Maandag, 16 Julie 1984.

Welkom: Maandag, 23 Julie 1984.

Observatory: Maandag, 13 Augustus 1984.

Port Elizabeth: Maandag, 20 Augustus 1984.

Manufactured by.—Conforce (Pty) Ltd, P.O. Box 82510, Southdale, 2135.

The validity of this certificate, which was issued under Notice 411 of 1981, dated 5 June 1981, is further extended for a period not exceeding six months.

(8 Junie 1984)

NOTICE 377 OF 1984

DEPARTMENT OF COMMUNITY DEVELOPMENT

AGRÉMENT BOARD OF SOUTH AFRICA (Approval of new building systems and products)

Notice is given hereby that the Agrément Board of South Africa has registered a change in a certificate holder's list of licensees who may manufacture/assemble/apply/erect the certificated product described and specified in the relevant certificate, as detailed in the Schedule hereto.

SCHEDULE

AGRÉMENT BOARD OF SOUTH AFRICA

Additions

(1) *Certificate holder.*—Gypsum Industries Limited.

Number and title of certificate for which licences have been issued.—No. 79/71, Gypsum Industries Brick Veneer Building System.

Names and addresses of licensees:

(1) Shield Timber Frame Homes, 9 Primarius Street, Strand, 7140.

(2) Elgin Timbers, P.O. Box 16, Grabouw, 7160.

(3) A.S.H. Brick Veneer Builders, 28 Baakens Road, Primrose Park, 7764.

(4) Structaframe (Pty) Ltd, P.O. Box 7123, Dinwiddie, 1405.

(2) *Certificate holder.*—Gypsum Industries Limited.

Number and title of certificate for which licence has been issued.—No. 79/74, Rhinoshield Building System.

Name and address of licensee.—Cape Modular Buildings (Pty) Ltd, P.O. Box 413, Parow, 7500.

(8 Junie 1984)

NOTICE 357 OF 1984

DEPARTMENT OF CO-OPERATION AND DEVELOPMENT

SOUTHERN DIVORCE COURT.—SESSIONS

The Director-General of Co-operation and Development has, in terms of section 13 (6) of the Black Administration Act, 1927 (Act 38 of 1927), and section 10 (4) of the Black Administration Act, 1927, Amendment Act, 1929 (Act 9 of 1929), determined the following as places at which and dates on which the Southern Divorce Court will commence sessions at 09h00 or as soon thereafter as may be convenient:

Kimberley: Monday, 2 July 1984.

Kroonstad: Friday, 6 July 1984.

Bloemfontein: Monday, 16 July 1984.

Welkom: Monday, 23 July 1984.

Observatory: Monday, 13 August 1984.

Port Elizabeth: Monday, 20 August 1984.

Queenstown: Maandag, 10 September 1984.
Bloemfontein: Dinsdag, 2 Oktober 1984.
Kimberley: Maandag, 15 Oktober 1984.
Kroonstad: Maandag, 15 Oktober 1984.
Welkom: Maandag, 22 Oktober 1984.
Port Elizabeth: Maandag, 19 November 1984.
Observatory: Dinsdag, 4 Desember 1984.

Queenstown: Monday, 10 September 1984.
Bloemfontein: Tuesday, 2 October 1984.
Kimberley: Monday, 15 October 1984.
Kroonstad: Monday, 15 October 1984.
Welkom: Monday, 22 October 1984.
Port Elizabeth: Monday, 19 November 1984.
Observatory: Tuesday, 4 December 1984.

8 Junie 1984)

(8 June 1984)

Werk mooi daarmee.

Ons leef  daarvan.

water is kosbaar

Use it.

Don't abuse  it.

water is for everybody

SOUTHERN CAPE FORESTS AND TREES

by

F. VON BREITENBACH

A guide to the indigenous forests of George, Knysna and Tsitsikama; their different types; their management and history; their trees and shrubs, ferns and herbs, grasses and lianes; their snakes, birds and mammals.

With a leaf-key to and descriptions of 100 forest tree species.

328 pages, 470 illustrations (photographs and line drawings), comprehensive index, hard cover.

Price R10 (Plus GST) • Abroad R12,50

Obtainable from the Government Printer, Pretoria and Cape Town

DEPARTEMENT VAN GEMEENSKAPS-
ONTWIKKELING

DIE STAATSDRUKKER

AMPTELIKE PUBLIKASIES ONTVANG
GEDURENDE MAART 1984

(Binnelandse pryse sluit nie verkooppelasting in)

RP-VERSLAE

RP 64/1983—Verslag van die Kommissie van Onderzoek insake die Bepaling, vir Inkomstebelastingdoeleindes, van die Waarde van Voordele (met inbegrip van toelae) Voortspruitend uit die Lewering van Diens of die Bekleding van 'n Amp en na Verwante Aangeleenthede. ISBN 0 621 08058 6. Plaaslik R4,80, buitelandse R5,70.

RP 75/1983—Verslag van die Ouditeur-generaal oor die Rekenings van die Departement van Pos- en Telekommunikasiewese vir die boekjaar 1982-83. ISBN 0 621 08369 0. Plaaslik R6,80, buitelandse R7,95.

RP 77/1983—Jaarverslag van die Kommissaris van die Suid-Afrikaanse Polisie vir die tydperk 1 Julie 1982 tot 30 Junie 1983. ISBN 0 621 08382 8. Plaaslik R4,70, buitelandse R5,55.

RP 79/1983—Registateur van Versekeringswese: Agt-en-dertigste Jaarverslag vir die jaar geëindig 31 Desember 1981. ISBN 0 621 08384 4. Plaaslik R10, buitelandse R11,70.

RP 1/1984—Begroting van die addisionele uitgawes wat uit die Staatsinkomsterekening gedurende die boekjaar wat op 31 Maart 1984 eindig, besty moet word. ISBN 0 621 08063 2. Plaaslik R9,30, buitelandse R10,90.

RP 2/1984—Begroting van die uitgawes wat uit die Staatsinkomsterekening gedurende die boekjaar wat op 31 Maart 1985 eindig, besty moet word. ISBN 0 621 08065 9. Plaaslik R10,70, buitelandse R12,50.

RP 3/1984—Begroting van inkomste vir die boekjaar wat op 31 Maart 1985 eindig. ISBN 0 621 08075 6. Plaaslik R2,50, buitelandse R2,95.

RP 5/1984—Begrotings van Bedryfsuitgawe van die Suid-Afrikaanse Vervoerdienste vir die boekjaar wat eindig op 31 Maart 1984 en 31 Maart 1985. ISBN 0 621 08073 X. Plaaslik R4,82, buitelandse R5,20.

RP 6/1984—Kapitaalbegrotings van die Suid-Afrikaanse Vervoerdienste vir die boekjare wat eindig op 31 Maart 1984 en 31 Maart 1985. ISBN 0 621 08071 3. Plaaslik R8, buitelandse R9,50.

RP 7/1984—Bedryfsbegrotings van die Suid-Afrikaanse Vervoerdienste vir die boekjare wat eindig op 31 Maart 1984 en 31 Maart 1985. ISBN 0 621 08074 8. Plaaslik R3,75, buitelandse R4,10.

RP 8/1984—Raad van S.A. Vervoerdienste Verslag, 1983. ISBN 0 621 08067 5. Plaaslik R12,30, buitelandse R14,40.

RP 10/1984—Begroting van addisionele uitgawe van die Departement van Pos- en Telekommunikasiewese vir die jaar wat op 31 Maart 1984 eindig. ISBN 0 621 08072 1. Plaaslik R0,50, buitelandse R0,60.

RP 11/1984—Begroting van Inkomste en Uitgawe van die Departement van Pos- en Telekommunikasiewese vir die jaar wat op 31 Maart 1985 eindig. ISBN 0 621 08077 2. Plaaslik R3,40, buitelandse R4.

RP 13/1984—Verslag van die Ouditeur-generaal oor die Rekenings van die Suid-Afrikaanse Vervoerdienste vir die boekjaar 1982-83. ISBN 0 621 08401 8. Plaaslik R6,10, buitelandse R7,15.

RP 14/1984—Verslag van die Ouditeur-generaal oor die Rekenings van die Eierbeheerraad vir die boekjaar 1 Julie 1982 tot 30 Junie 1983. ISBN 0 621 08413 1. Plaaslik R0,90, buitelandse R1.

RP 15/1984—Verslag van die Ouditeur-generaal oor die Rekenings van die Suivelraad vir die boekjaar 1 Maart 1982 tot 28 Februarie 1983. ISBN 0 621 08428 X. Plaaslik R0,90, buitelandse R1.

RP 19/1984—Verslag van die Ouditeur-generaal oor die Rekenings van die Suid-Afrikaanse Wolraad vir die boekjaar 1 Julie 1982 tot 30 Junie 1983. ISBN 0 621 08436 0. Plaaslik R0,80, buitelandse R1.

RP 24/1984—Nasionale Mannekragskommissie: Indiensopleiding in die Republiek van Suid-Afrika, 1980/81. ISBN 0 621 08502 2. Plaaslik R4, buitelandse R4,70.

RP 25/1984—Verslag van die Ouditeur-generaal oor die Rekenings van die Administrasieraad, Port Natalgebied, vir die boekjaar 1982-83. ISBN 0 621 08503 0. Plaaslik R0,90, buitelandse R1.

RP 26/1984—Verslag van die Ouditeur-generaal oor die Rekenings van die Administrasieraad, Noord-Kaapgebied, vir die boekjaar 1982-83. ISBN 0 621 08504 9. Plaaslik R0,90, buitelandse R1.

STATISTIEKE VERSLAE

23-04-01—Sensus van Argitekte en Bourekenaars, 1979. ISBN 0 621 08107 8. Plaaslik R2,10, buitelandse R2,50.

Bulletin van Statistiek vir die kwartaal geëindig Maart 1984. Vol. 18, No 1. ISSN 0034 5024. Plaaslik R4,20, buitelandse R5.

Maandelikse Uittreksel van Handelstatistieke, Januarie tot Oktober 1983. Plaaslik R4,80, buitelandse R5,70.

DEPARTMENT OF COMMUNITY
DEVELOPMENT

THE GOVERNMENT PRINTER

OFFICIAL PUBLICATIONS RECEIVED
DURING MARCH 1984

(Local prices do not include general sales tax)

RP-REPORTS

RP 64/1983—Report of the Commission of Inquiry in regard to the Determination, for Income Tax purposes, of the Value of Benefits (including allowances) Arising from Employment or the Holding of an Office and to Related Matters. ISBN 0 621 08058 6. Local R4,80, other countries R5,70.

RP 75/1983—Report of the Auditor-General on the Accounts of the Department of Posts and Telecommunications for the financial year 1982-83. ISBN 0 621 08369 0. Local R6,80, other countries R7,95.

RP 77/1983—Annual Report of the Commissioner of the South African Police for the period 1 July 1982 to 30 June 1983. ISBN 0 621 08381 X. Local R4,70, other countries R5,55.

RP 79/1983—Registrar of Insurance: Thirty-eighth Annual Report for the year ended 31 December 1981. ISBN 0 621 08384 4. Local R10, other countries R11,70.

RP1/1984—Estimate of the additional expenditure to be defrayed from the State Revenue Account during the financial year ending 31 March 1984. ISBN 0 621 08063 2. Local R9,30, other countries R10,90.

RP 2/1984—Estimate of the Expenditure to be defrayed from the State Revenue Account during the financial year ending 31 March 1985. ISBN 0 621 08065 9. Local R10,70, other countries R12,50.

RP 3/1984—Estimate of revenue for the financial year ending 31 March 1985. ISBN 0 621 08075 6. Local R2,50, other countries R2,95.

RP 5/1984—Estimates of Working Expenditure of the South African Transport Services for the financial years ending 31 March 1984 and 31 March 1985. ISBN 0 621 08073 X. Local R4,82, other countries R5,20.

RP 6/1984—Capital budget of the South African Transport Services for the financial year ending 31 March 1984 and 31 March 1985. ISBN 0 621 08074 8. Local R8, other countries R9,50.

RP 7/1984—Working Estimates of the South African Transport Services for the financial years ending 31 March 1984 and 31 March 1985. ISBN 0 621 08074 8. Local R3,75, other countries R4,10.

RP 8/1984—S.A. Transport Services Board Report, 1983. ISBN 0 621 08067 5. Local R12,30, other countries R14,40.

RP 11/1984—Estimates of Revenue and Expenditure of the Department of Posts and Telecommunications for the year ending 31 March 1985. ISBN 0 621 08077 2. Local R3,40, other countries R4.

RP 13/1984—Report of the Auditor-General on the Accounts of the South African Transport Services for the financial year 1982-83. ISBN 0 621 08401 8. Local R6,10, other countries R7,15.

RP 14/1984—Report of the Auditor-General on the Accounts of the Egg Control Board for the financial year 1 July 1982 to 30 June 1983. ISBN 0 621 08413 1. Local R0,90, other countries R1.

RP 15/1984—Report of the Auditor-General on the Accounts of the Dairy Board for the financial year 1 March 1982 to 28 February 1983. ISBN 0 621 08428 X. Local R0,90, other countries R1.

RP 19/1984—Report of the Auditor-General on the Accounts of the South African Wool Board for the financial year 1 July 1982 to 30 June 1983. ISBN 0 621 08436 0. Local R0,80, other countries R1.

RP 24/1984—National Manpower Commission: In-service Training in the Republic of South Africa, 1980/81. ISBN 0 621 08502 2. Local R4, other countries R4,70.

RP 25/1984—Report of the Auditor-General on the Accounts of the Port Natal Area Administration Board for the financial year 1982-83. ISBN 0 621 08503 0. Local R0,90, other countries R1.

RP 26/1983—Report of the Auditor-General on the Accounts of the Northern Cape Area Administration Board for the financial year 1982-83. ISBN 0 621 08504 9. Local R0,90, other countries R1.

STATISTICAL REPORTS

23-04-01—Census of Architects and Quantity Surveyors, 1979. ISBN 0 621 08107 8. Local R2,10, other countries R2,50.

Bulletin of Statistics for the quarter ended March 1984. Vol. 18, No 1. ISSN 0034 5024. Local R4,20, other countries R5.

Monthly Abstract of Trade Statistics, January-October 1983. Local R4,80, other countries R5,70.

DIVERSE VERSLAE

Verslag van die Tegnieuse Komitee van Ondersoek na die Wet op Groepsgebiede, 1966; Die Wet op Aanwysing van Aparte Geriewe, 1953, en Aanverwante Wetgewing. Plaaslik R5,30, buitelandse R6,20.

Bibliography and Subject Index of South African Geology, 1982. ISBN 0 621 08443 3. (Slegs in Engels.) Plaaslik R2,10, buitelandse R2,50.

Statistiese/Ekonomiese Oorsig Begroting, 1984/85 (WPB-'84) ISBN 0 621 08532 4. Plaaslik R2, buitelandse R2,50.

Patentjoernaal (insluitende Handelsmerke, Modelle en Outeursreg in Rolprente). Februarie 1984, Vol. 17, No. 2. ISSN 0031 286X. Plaaslik R1, buitelandse R1,25.

Patentjoernaal (insluitende Handelsmerke, Modelle en Outeursreg in Rolprente). Maart 1984, Vol. 17, No. 3. ISSN 0031 286X. Plaaslik R1, buitelandse R1,25.

MISCELLANEOUS

Report of the Technical Committee of Enquiry into the Group Areas Act, 1966; The Reservation of Separate Amenities Act, 1953, and Related Legislation. Local R5,30, other countries R6,20.

Bibliography and Subject Index of South African Geology, 1982. ISBN 0 621 08443 3. Local R2,10, other countries R2,50.

Statistical/Economic Review Budget, 1984/85 (WPB-'84) ISBN 0 621 08532 4. Local R2, other countries R2,50.

Patent Journal (including Trade Marks, Designs and Copyright in Cinematography Films). February 1984. Vol. 17, No. 2. ISSN 0031 286X. Local R1, other countries R1,25.

Patent Journal (including Trade Marks, Designs and Copyright in Cinematography Films). March 1984. Vol. 17, No. 3. ISSN 0031 286X. Local R1, other countries R1,25.

KAARTE

Skaal	Type	No.	Beskrywing	Uitgawe	Datum	Nuwe of herdruk
1:1 000 000	Lugvaart	3 275	Bulawayo	3de	1983	Nuwe.
1:500 000	Lugvaart	2 722	Kimberley	1ste	1983	Nuwe.
1:500 000	Lugvaart	2 518	Keetmanshoop	1ste	1983	Nuwe.
1:500 000	Admin	2 726	Kroonstad	1ste	1978	Herdruk.
1:500 000	Topo	2 514	Lüderitz	1ste	1978	Herdruk.
1:250 000	Topo Kad.	2 530	Barberton	4de	1976	Herdruk.
1:250 000	Topo Kad.	2 328	Pietersburg	4de	1970	Herdruk.
1:250 000	Topo Kad.	3 326	Grahamstad	2de	1977	Herdruk.
1:50 000	Topo	2 626 AB	Twee Buffels	1ste	1977	Herdruk.
1:50 000	Topo	2 729 AA	Ascent	1ste	1969	Herdruk.
1:50 000	Topo	2 730 AA	Latemanek	1ste	1969	Herdruk.
1:50 000	Topo	2 626 CC	Ottosdal	1ste	1967	Herdruk.
1:50 000	Topo	2 626 BB	Swartplaas	1ste	1974	Herdruk.
1:50 000	Topo	2 431 DC	Skukuza	1ste	1971	Herdruk.
1:50 000	Topo	2 930 BA	Greytown	2de	1976	Herdruk.
1:50 000	Topo	2 922 CB	Fransenhof	1ste	1971	Herdruk.
1:50 000	Topo	2 726 BA	Vaalbrug	2de	1976	Herdruk.
1:50 000	Topo	2 625 DA	Baberspan	1ste	1972	Herdruk.
1:50 000	Topo	2 625 CA	Kameel	1ste	1974	Herdruk.
1:50 000	Topo	2 930 DD	Durban	6de	1982	Nuwe.
1:50 000	Topo	2 931 CC	Dundee	2de	1981	Herdruk.
1:50 000	Topo	2 620 BC & BD	Twee Rivieren	1ste	1971	Herdruk.
1:50 000	Topo	2 921 DA	Angelienspan	1ste	1971	Herdruk.
1:50 000	Topo	2 420 CA & CC	Bredasdorp	2de	1969	Herdruk.

Plaaslik R1,04, buitelandse R1,25.

MAPS

Scale	Type	No.	Description	Edition	Date	New or reprint
1:1 000 000	Aeronautical	3 275	Bulawayo	3rd	1983	New.
1:500 000	Aeronautical	2 722	Kimberley	1st	1983	New.
1:500 000	Aeronautical	2 518	Keetmanshoop	1st	1983	New.
1:500 000	Admin	2 726	Kroonstad	1st	1978	Reprint.
1:500 000	Topo	2 514	Lüderitz	1st	1978	Reprint.
1:250 000	Topo Cad.	2 530	Barberton	4th	1976	Reprint.
1:250 000	Topo Cad.	2 328	Pietersburg	4th	1970	Reprint.
1:250 000	Topo Cad.	3 326	Grahamstown	2nd	1977	Reprint.
1:50 000	Topo	2 626 AB	Twee Buffels	1st	1977	Reprint.
1:50 000	Topo	2 729 AA	Ascent	1st	1969	Reprint.
1:50 000	Topo	2 730 AA	Latemanek	1st	1969	Reprint.
1:50 000	Topo	2 626 CC	Ottosdal	1st	1967	Reprint.
1:50 000	Topo	2 626 BB	Swartplaas	1st	1974	Reprint.
1:50 000	Topo	2 431 DC	Skukuza	1st	1971	Reprint.
1:50 000	Topo	2 930 BA	Greytown	2nd	1976	Reprint.
1:50 000	Topo	2 922 CB	Fransenhof	1st	1971	Reprint.
1:50 000	Topo	2 726 BA	Vaalbrug	2nd	1976	Reprint.
1:50 000	Topo	2 625 DA	Baberspan	1st	1972	Reprint.
1:50 000	Topo	2 625 CA	Kameel	1st	1974	Reprint.
1:50 000	Topo	2 930 DD	Durban	6th	1982	New.
1:50 000	Topo	2 931 CC	Dundee	2nd	1981	Reprint.
1:50 000	Topo	2 620 BC & BD	Twee Rivieren	1st	1971	Reprint.
1:50 000	Topo	2 921 DA	Angelienspan	1st	1971	Reprint.
1:50 000	Topo	2 420 CC & CA	Bredasdorp	2nd	1969	Reprint.

Local R1,04, other countries R1,25.

KOOP VERDEDIGINGSBONUSOBLIGASIES
BUY DEFENCE BONUS BONDS

Staatskoerant
van die Republiek van Suid-Afrika

VOORWAARDES VIR DIE PUBLIKASIE
VAN WETLIKE KENNISGEWINGS

Sluitingstye vir die aanname van kennisgewings

1. Die *Staatskoerant* word weekliks op Vrydag gepubliseer en die sluitingstyd vir die aanname van kennisgewings wat op 'n bepaalde Vrydag in die *Staatskoerant* moet verskyn, is 15h00 op die voorafgaande Vrydag. Indien enige Vrydag saamval met 'n openbare vakansiedag, verskyn die *Staatskoerant* op 'n datum en is die sluitingstye vir die aanname van kennisgewings soos van tyd tot tyd in die *Staatskoerant* bepaal.

2. (1) Wanneer 'n aparte *Staatskoerant* verlang word moet dit drie kalenderweke voor publikasie ingedien word.

(2) Kopie van kennisgewings wat na sluitingstyd ontvang word, sal oorgehou word vir plasing in die eersvolgende *Staatskoerant*.

(3) Wysiging van of veranderings in die kopie van kennisgewings kan nie onderneem word nie tensy opdragte daarvoor ontvang is voor 15h30 op Maandae.

(4) Kopie van kennisgewings vir publikasie kan nie oor die telefoon aangeneem word nie.

(5) In geval van kanselleries sal die terugbetaling van die koste van 'n kennisgewing oorweeg word slegs as die opdrag om te kanselleer op of voor die vasgestelde sluitingstyd soos in paragraaf 1 hierbo aangedui, ontvang is.

Goedkeuring van kennisgewings

3. Kennisgewings, behalwe wetlike kennisgewings, is onderworpe aan die goedkeuring van die Staatsdrukker wat kan weier om enige kennisgewing aan te neem of verder te publiseer.

Vrywaring van die Staatsdrukker teen aanspreeklikheid

4. Die Staatsdrukker aanvaar geen aanspreeklikheid vir—

(1) enige vertraging by die publikasie van 'n kennisgewing of vir die publikasie daarvan op 'n ander datum as dié deur die adverteerder bepaal;

(2) die foutiewe klassifikasie van 'n kennisgewing of die plasing daarvan onder 'n ander afdeling of opskrif as die afdeling of opskrif wat deur die adverteerder aangedui is;

(3) enige redigering, hersiening, weglating, tipografiese foute of foute wat weens dowwe of onduidelike kopie mag ontstaan.

Aanspreeklikheid van adverteerder

5. Die adverteerder word aanspreeklik gehou vir enige skadevergoeding en koste wat ontstaan uit enige aksie wat weens die publikasie van 'n kennisgewing teen die Staatsdrukker ingestel mag word.

Kopie

6. Die kopie van kennisgewings moet slegs op een kant van die papier getik wees en mag nie deel van enige begeleidende brief of dokument uitmaak nie.

7. Bo aan die kopie, en weg van die kennisgewing, moet die volgende aangedui word:

(1) Die aard van die kennisgewing;

(2) die opskrif waaronder die kennisgewing geplaas moet word;

(3) die tarief (bv. "Vaste tarief", of "Woordetal-tarief") wat op die kennisgewing van toepassing is, en die koste verbonde aan die plasing daarvan.

8. Alle eiename en familienaam moet duidelik leesbaar wees en familienaam moet onderstreep of in hoofletters getik word. Indien 'n naam verkeerd gedruk word as gevolg van onduidelike skrif, sal die kennisgewing alleen na betaling van die koste van 'n nuwe plasing weer gepubliseer word.

Betaling van koste

9. Geen kennisgewing word vir publikasie aanvaar nie tensy die koste van die plasing(s) daarvan vooruit betaal is deur middel van ongekanselleerde inkomsteseëls.

10. (1) Die koste van 'n kennisgewing moet deur die adverteerder bereken word in ooreenstemming met—

(a) die lys van vaste tariewe; of

(b) indien die vaste tariewe nie van toepassing is nie, die woordetal-tariewe.

(2) In gevalle van twyfel oor die koste verbonde aan die plasing van 'n kennisgewing en in die geval van kopie met meer as 1 600 woorde, moet 'n navraag, vergesel van die betrokke kopie, voor publikasie aan die Advertensie-afdeling, Staatsdrukkery, Privaatsak X85, Pretoria, 0001, gerig word.

11. Ongekanselleerde inkomsteseëls wat die juiste bedrag van die koste van 'n kennisgewing of die totaal van die koste van meerdere kennisgewings verteenwoordig, moet op die kopie geplak word.

Government Gazette
of the Republic of South Africa

CONDITIONS FOR THE PUBLICATION OF
LEGAL NOTICES

Closing times for the acceptance of notices

1. The *Government Gazette* is published every week on Friday, and the closing time for the acceptance of notices which have to appear in the *Government Gazette* on any particular Friday, is 15h00 on the preceding Friday. Should any Friday coincide with a public holiday, the date of publication of the *Government Gazette* and the closing time of the acceptance of notices will be published in the *Government Gazette*, from time to time.

2. (1) The copy for a separate *Government Gazette* must be handed in not later than three calendar weeks before date of publication.

(2) Copy of notices received after closing time will be held over for publication in the next *Government Gazette*.

(3) Amendment or changes in copy of notices cannot be undertaken unless instructions are received before 15h30 on Mondays.

(4) Copy of notices for publication cannot be accepted over the telephone.

(5) In the case of cancellations a refund of the cost of a notice will be considered only if the instruction to cancel has been received on or before the stipulated closing time as indicated in paragraph 1 above.

Approval of notices

3. Any notices other than legal notices are subject to the approval of the Government Printer, who may refuse acceptance or further publication of any notice.

The Government Printer indemnified against liability

4. The Government Printer will assume no liability in respect of—

(1) any delay in the publication of a notice or publication of such notice on any date other than that stipulated by the advertiser;

(2) erroneous classification of a notice, or the placement of such notice in any section or under any heading other than the section or heading stipulated by the advertiser;

(3) any editing, revision, omission, typographical errors or errors resulting from faint or indistinct copy.

Liability of advertiser

5. Advertisers will be held liable for any compensation and costs arising from any action which may be instituted against the Government Printer in consequence of the publication of any notice.

Copy

6. Copy of notices must be typed on one side of the paper only and may not constitute part of any covering letter or document.

7. At the top of any copy, and set well apart from the notice the following must be stated:

(1) The kind of notice;

(2) the heading under which the notice is to appear;

(3) the rate (e.g. "Fixed tariff rate", or "Word count rate") applicable to the notice, and the cost of publication.

8. All proper names and surnames must be clearly legible, surnames being underlined or typed in capital letters. In the event of a name being incorrectly printed as a result of indistinct writing, the notice will be republished only upon payment of the cost of a new insertion.

Payment of cost

9. No notice will be accepted for publication unless the cost of the insertion(s) is prepaid by way of uncancelled revenue stamps.

10. (1) The cost of a notice must be calculated by the advertiser in accordance with—

(a) the list of fixed tariff rates; or

(b) where the fixed tariff rate does not apply, the word count rate.

(2) Where there is any doubt about the cost of publication of a notice, and in the case of copy in excess of 1 600 words, an enquiry, accompanied by the relevant copy should be addressed to the Advertising Section, Government Printing Works, Private Bag X85, Pretoria, 0001, before publication.

11. Uncancelled revenue stamps representing the correct amount of the cost of publication of a notice, or the total of the cost of publication of more than one notice, must be affixed to the copy.

12. Oorbetalings op grond van 'n foutiewe berekening van die koste verbode aan die plasing van 'n kennisgewing deur die adverteerder word nie terugbetaal nie tensy die adverteerder voldoende redes aantoon waarom 'n foutiewe berekening gemaak is. In die geval van onderbetalings sal die verskil van die adverteerder verhaal word en geen plasing sal geskied voordat die volle koste verbode aan die plasing van die kennisgewing(s) deur middel van ongekanselleerde inkomsteseëls betaal is nie.

13. Die Staatsdrukker behou hom die reg voor om 'n bykomende bedrag te hef in gevalle waar kennisgewings, waarvan die koste in ooreenstemming met die lys van vaste tariewe bereken word, later uitermatig lank blyk te wees of buitensporige of ingewikkelde tabelwerk bevat.

Bewys van publikasie

14. Eksemplare van die *Staatskoerant* wat nodig mag wees ter bewys van publikasie van 'n kennisgewing kan teen 40c in die vorm van ongekanselleerde inkomsteseëls per eksemplaar van die Staatsdrukker bestel word. Geen aanspreeklikheid word aanvaar vir die versuim om sodanige *Staatskoerant(e)* te pos of vir vertraging in die versending daarvan nie.

Let wel asseblief!

Nuwe advertensietariewe vanaf 1 Januarie 1984.

LYS VAN VASTE TARIIEWE

Gestandaardiseerde kennisgewings	Tarief per plasing
	R
Akte: Verlore dokumente (Een akte en nie meer as 6 eiendomme per dokument nie. Meer as 6 eiendomme moet volgens woordetal-tabel bereken word).....	7,00
Besigheidskennisgewings.....	6,00
Boedelwettekennisgewings: Vorms J 297, J 295, J 193 en J 187.....	2,50
Derdeparty-assuransie-eise om skadevergoeding.....	3,00
Insolvensiewet- en maatskappywettekennisgewings: J 28, J 29, Vorms 1 tot 9.....	5,00
L.W.—Vorms 2 en 9—bykomstige verklarings volgens woordetal-tabel, toegevoeg tot die basiese tarief.	
Naamsverandering (twee plasinge).....	26,50
Onopgeëiste geld—slegs in die buitengewone <i>Staatskoerant</i> , sluitingsdatum 15 Januarie (per inskrywing van "naam, adres en bedrag").....	1,00
Slagterskennisgewings.....	6,00
Slumopruimingshofkennisgewings, per taal, perseel.....	5,00
Verlore lewensversekeringspolisie.....	2,50
Nie-gestandaardiseerde kennisgewings	
Dranklisensie-kennisgewings in buitengewone <i>Staatskoerant</i>:	
(i) Transvaal verskyn voorlaaste Vrydag in Junie. Sluitingsdatum vir indiening eerste Vrydag in Junie.....	8,50
(ii) Kaap verskyn voorlaaste Vrydag in November. Sluitingsdatum vir indiening eerste Vrydag in November.....	8,50
(iii) OVS verskyn voorlaaste Vrydag in Januarie. Sluitingsdatum vir indiening eerste Vrydag in Januarie.....	8,50
(iv) Natal verskyn voorlaaste Vrydag in April. Sluitingsdatum vir indiening eerste Vrydag in April.....	8,50
Laat aansoek vir plasing in gewone <i>Staatskoerant</i>	60,00
Geregtelike en ander openbare verkope:	
Geregtelike verkope.....	22,00
Openbare veilinge, verkope en tenders:	
Tot 75 woorde.....	7,00
76 tot 250 woorde.....	18,00
251 tot 350 woorde (meer as 350 woorde bereken volgens woordetal-tabel).....	28,00
Handelsmerke in Suidwes-Afrika.....	13,00
Likwidateurs en ander aangesteldes se kennisgewings.....	8,50
Maatskappykennisgewings:	
Kort kennisgewings: Vergaderings, besluite, aanbod van skikking, omskepping van maatskappy, vrywillige likwidasies, ens.: sluiting van oordrag- of lederegisters en/of verklaring van dividende.....	13,00
Verklaring van dividende met profytstate, notas ingesluit.....	30,00
Lang kennisgewings: Oordragte, veranderings met betrekking tot aandele of kapitaal, aflossings, besluite, vrywillige likwidasies.....	45,00
Orders van die Hof:	
Voorlopige en finale likwidasies of sekwestrasies.....	17,00
Verlagings of veranderings in kapitaal, samesmeltings, aanbod van skikking.....	45,00
Geregtelike besture, <i>curator bonis</i> en soortgelyke en uitgebreide bevels <i>nisi</i>	45,00
Verlenging van keerdatum.....	5,00
Tersyderstelling en afwysings van petisies (J 158).....	5,00

12. Overpayments resulting from miscalculation on the part of the advertiser of the cost of publication of a notice will not be refunded, unless the advertiser furnishes adequate reasons why such miscalculation occurred. In the event of underpayments, the difference will be recovered from the advertiser, and the notice(s) will not be published until such time as the full cost of such publication has been duly paid in uncanceled revenue stamps.

13. The Government Printer reserves the right to levy an additional charge in cases where notices, the cost of which has been calculated in accordance with the list of fixed tariff rates, are subsequently found to be excessively lengthy or to contain overmuch or complicated tabulation.

Proof of publication

14. Copies of the *Government Gazette* which may be required as proof of publication may be ordered from the Government Printer at 40c, payment to be effected by way of uncanceled revenue stamps. The Government Printer will assume no liability for any failure to post such *Government Gazette(s)* or for any delay in dispatching it/them.

Please Note!

Tariff rates change from 1 January 1984.

LIST OF FIXED TARIFF RATES

Standardised notices	Rate per insertion
	R
Administration of Estates Acts notices: Forms J 297, J 295, J 193 and J 187.....	2,50
Business notices.....	6,00
Butcher's notices.....	6,00
Change of name (two insertions).....	26,50
Deeds: Lost documents (One deed and not more than 6 properties per document. More than 6 properties must be calculated in accordance with the word count table).....	7,00
Insolvency Act and Company Acts notices: J 28, J 29, Forms 1 to 9.....	5,00
N.B.—Forms 2 and 9—additional statements according to word count table, added to the basic tariff.	
Lost life insurance policies.....	2,50
Naturalisation notices (including a reprint for the advertiser).....	2,50
Slum Clearance Court notices, per language per premises.....	5,00
Third party insurance claims for compensation.....	3,00
Unclaimed moneys—only in the extraordinary <i>Government Gazette</i> , closing date 15 January (per entry of "name, address and amount").....	1,00
Non-standardised notices	
Company notices:	
Short notices: Meetings, resolutions, offer of compromise, conversion of company, voluntary windings-up; closing of transfer or members' registers and/or declaration of dividends.....	13,00
Declaration of dividend with profit statements, including notes.....	30,00
Long notices: Transfer, changes with respect to shares or capital, redemptions, resolutions, voluntary liquidations ..	45,00
Liquidator's and other appointees' notices.....	8,50
Liquor Licence notices in extraordinary <i>Gazette</i>:	
(i) Transvaal appear on last Friday but one in June. Closing date for acceptance first Friday in June.....	8,50
(ii) Cape appear on last Friday but one in November. Closing date for acceptance first Friday in November.....	8,50
(iii) OVS appear on last Friday but one in January. Closing date for acceptance first Friday in January.....	8,50
(iv) Natal appear on last Friday but one in April. Closing date for acceptance first Friday in April.....	8,50
Late applications for publication in ordinary <i>Government Gazette</i>	60,00
Orders of the Court:	
Provisional and final liquidations or sequestrations.....	17,00
Reductions or changes in capital, mergers, offer of compromise.....	45,00
Judicial managements, <i>curator bonis</i> and similar and extensive rules <i>nisi</i>	45,00
Extension of return date.....	5,00
Supersessions and discharge of petitions (J 158).....	5,00
Sales in execution and other public sales:	
Sales in execution.....	22,00
Public auctions, sales and tenders:	
Up to 75 words.....	7,00
76 to 250 words.....	18,00
251 to 350 words (More than 350 words—calculate in accordance with word count table).....	28,00
Trade Marks in South West Africa.....	13,00

WOORDETAL-TABEL

Vir algemene kennisgewings wat nie onder bovermelde opskrifte met vaste tariewe resorteer nie en wat 1 600 of minder woorde beslaan, moet die tabel van woordetal-tariewe gebruik word. Kennisgewings met meer as 1 600 woorde, of waar twyfel bestaan, moet vooraf ingestuur word soos in die Voorwaardes, paragraaf 10 (2), voorgeskryf.

WORD COUNT TABLE

For general notices which do not belong under above-mentioned headings with fixed tariff rates and which comprise 1 600 or less words, the rates of the word count table must be used. Notices with more than 1 600 words, or where doubt exists, must be sent in before publication as prescribed in paragraph 10 (2), of the Conditions.

Aantal woorde in kopie Number of words in copy	Een plasing One insertion	Twee plasinge Two insertions	Drie plasinge Three insertions	Vier plasinge Four insertions
	R	R	R	R
1- 100.....	8,50	13,00	18,00	23,00
101- 150.....	13,00	19,00	27,00	33,00
151- 200.....	17,00	25,00	35,00	44,00
201- 250.....	21,00	31,00	43,00	55,00
251- 300.....	25,00	37,00	51,00	66,00
301- 350.....	29,00	43,00	60,00	77,00
351- 400.....	34,00	49,00	68,00	87,00
401- 450.....	38,00	55,00	77,00	98,00
451- 500.....	42,00	61,00	85,00	109,00
501- 550.....	46,00	67,00	93,00	120,00
551- 600.....	50,00	73,00	102,00	131,00
601- 650.....	54,00	79,00	110,00	141,00
651- 700.....	59,00	85,00	119,00	152,00
701- 750.....	63,00	91,00	127,00	163,00
751- 800.....	67,00	97,00	135,00	174,00
801- 850.....	71,00	103,00	144,00	185,00
851- 900.....	75,00	109,00	152,00	195,00
901- 950.....	80,00	116,00	161,00	206,00
951-1 000.....	84,00	121,00	169,00	217,00
1 001-1 300.....	108,00	165,00	223,00	281,00
1 301-1 600.....	129,00	197,00	264,00	331,00

AANSOEKE OM OPENBARE PADVERVOERPERMITTE

Sluitingstye vir die aanname van kennisgewings

Kennisgewings moet nie later as 15h00 op die Vrydag, twee kalenderweke voor datum van publikasie, ingedien word nie.

APPLICATIONS FOR PUBLIC ROAD CARRIER PERMITS

Closing times for the acceptance of notices

Notices must be handed in not later than 15h00 on the Friday, two calendar weeks before the date of publication.

BELANGRIKE AANKONDIGING

SLUITINGSTYE VIR WETLIKE KENNISGEWINGS EN GOEWERMENSKENNISGEWINGS

1984

Die sluitingstyd is stiptelik 15h00 op die volgende dae:

- 4 Oktober, Donderdag, vir die uitgawe van Vrydag 12 Oktober.
- 13 Desember, Donderdag, vir die uitgawe van Vrydag 21 Desember.
- 18 Desember, Dinsdag, vir die uitgawe van Vrydag 28 Desember.
- 27 Desember, Donderdag, vir die uitgawe van Vrydag 4 Januarie 1985.

Laat kennisgewings sal in die daaropvolgende uitgawe geplaas word. Indien 'n laat kennisgewing wel, onder spesiale omstandighede aanvaar word, sal 'n dubbeltarief gehef word.

Wanneer 'n aparte *Staatskoerant* verlang word moet die kopie drie kalenderweke voor publikasie ingedien word.

IMPORTANT ANNOUNCEMENT

CLOSING TIMES FOR LEGAL NOTICES AND GOVERNMENT NOTICES

1984

The closing time is 15h00 sharp on the following days:

- 4 October, Thursday, for the issue of Friday 12 October.
- 13 December, Thursday, for the issue of Friday 21 December.
- 18 December, Tuesday, for the issue of Friday 28 December.
- 27 December, Thursday, for the issue of Friday 4 January 1985.

Late notices will be published in the subsequent issue. If, under special circumstances, a late notice is being accepted, a double tariff will be charged.

The copy for a separate *Government Gazette* must be handed in not later than three calendar weeks before date of publication.

BESIGHEIDSKENNISGEWINGS • BUSINESS NOTICES**VERVREEMDING, VERKOPE, VERANDERINGS VAN VENNOOTSKAP, NAAM, ADRES, ENS.**

Kennisgewing geskied hiermee ingevolge die bepalings van artikel 34 (1) van die Insolvensiewet, No. 24 van 1936, aan belanghebbende partye en skuldeisers van voorgenome vervreemding van besighede en/of klandisie, goedere of eiendom wat 'n deel vorm van besighede, na 'n tydperk van 30 dae vanaf die laaste publikasie van betrokke advertensies, en van aksies, omstandighede of voorwaardes wat op besighede of partye van skuldenaars, soos daarin genoem, betrekking het.

Die inligting word, waar van toepassing, verstrek in die volgorde: (1) Dorpsgebied of distrik, afdeling, county; (2) verkoper, handelaar, vennootskap; (3) besigheid of handel, soort, naam en/of styl, en adres waar gedryf; (4) doel en voorneme (vervreemding, verkoop, oorgawe, verandering of ontbinding van vennootskap, verhuising of adresverandering, naamverandering, kansellasië van verkoop, ens.); voorwaardes, en datum of tydperk indien anders as 30 dae; (5) koper, nuwe besitter en/of eienaar of vennoot, of kontrakterende party; (6) besigheid en adres, indien anders as onder (3); opmerkings, kommentaar; (7) adverteerder en/of agent, adres en datum.

ALIENATION, SALES, CHANGES OF PARTNERSHIP, NAME, ADDRESS, ETC.

Notice is hereby given in terms of section 34 (1) of the Insolvency Act, No. 24 of 1936, to interested parties and creditors of the intention of alienation of business and/or goodwill, goods or property forming part of businesses, after a period of 30 days from the last publication of relevant advertisements, and of actions, circumstances or conditions pertaining to businesses or parties or debtors, as mentioned therein.

The information, where applicable, is given in the following order: (1) Township or district, division, county; (2) seller, trader, partnership; (3) business or trade, kind, name and/or style, and the address at which carried on; (4) purpose and intent (alienation, sale, abandonment, change or dissolution of partnership, removal or change of address, change of name, cancellation of sale, etc.); conditions, and date or period of time if other than 30 days; (5) purchaser, new proprietor and/or owner or partner, or contracting party; (6) business and address, if other than under (3); notes, comment; (7) advertiser and/or agent, address and date.

TRANSVAAL**KENNISGEWING**

Kennis geskied hiermee ooreenkomstig artikel 34 van Wet No. 24 van 1936, soos gewysig, dat **Martha Hermina Vermeulen** van voorneme is om die besigheid bekend as **Video Nook** te verkoop en oor te dra aan **Johannes Petrus van den Berg en Cornelia de Milander van den Berg** wat die besigheid sal voortsit by dieselfde adres onder dieselfde naam vir sy/haar uitsluitlike voordeel en rekening vanaf 1 Mei 1984.

Gedateer te Vereeniging hierdie 14de dag van Mei 1984.

D. J. Malan & Hoffman, Cicerogebou, Lesliestraat 14, Posbus 415, Vereeniging, 1930.

KENNISGEWING

Kennis geskied hiermee ooreenkomstig artikel 34 van Wet 24 van 1936 (soos gewysig) dat **William Henry John Nel** van voorneme is om die handelaarsbesigheid bekend as **Billy's Fishing and Camping** te Tweede Laan 29, Springs, te verkoop en oor te dra aan **Jacobus Herklas du Preez** wat die besigheid sal voortsit by dieselfde adres onder die naam **East Rand Fishing and Camping** vir sy uitsluitlike voordeel en rekening binne 30 (dertig) dae vanaf die laaste publikasie van hierdie kennisgewing.

VERKOOP VAN BESIGHEID

Kennis word hiermee gegee in terme van artikel 34 van Wet 24 van 1936, soos gewysig, dat **Mev. E. du Preez** van voorneme is om haar besigheid **Video I** te verkoop en oor te dra aan **Gregory Frederick Lamb** en **Peter Donald Williams** wat besigheid sal doen onder die naam van **Video I** te Voortrekkerweg 614, Brakpan, vir sy eie voordeel en rekening vanaf 'n datum 30 (dertig) dae vanaf laaste publikasie hiervan.

Trollip, Joubert, Cowling & Jancke, Kingswaylaan 125a, Brakpan.

VERVREEMDING VAN BESIGHEID

Kennisgewing geskied hiermee in terme van artikel 34 van Wet 24 van 1936, soos gewysig, dat **Alike Agathonike Loupos**, gebore Savva Romanos met Identiteitsnommer 5404090070003, en hierinlater behoortlik bygestaan deur haar man en wettige eggenoot **Eleftherious Loupos** met Identiteitsnommer 5101065004104, die besigheid bekend as **Super Restaurant** verkoop het aan **Jacobus Johannes Barnard** met Identiteitsnommer 4308195058006, wat die besigheid onder dieselfde naam, **Super Restaurant**, sal voortsit vir sy eie rekening vanaf 1 April 1984.

Die partye gee ook kennis dat alle aanspreeklikheid ten opsigte van skulde aangegaan voor 1 April 1984 rus op die genoemde **Alike Agathonike Loupos** (gebore Savva Ramanos) en skulde aangegaan na die datum van oornome, naamlik 1 April 1984, sal rus op **Jacobus Johannes Barnard**.

Geteken te Standerton op hede die 7de dag van Mei 1984.

I. Fisher Van den Berg & Nel, Prokureurs vir die Partye, Kerkstraat 19c, Posbus 55, Standerton, 2430.

VERKOOP VAN BESIGHEID

Ingevolge artikel 34 (1) van die Insolvensie Wet, No. 24 van 1936, geskied kennis hiermee dat **Andries Willem Norval** wat besigheid dryf onder die saak naam **Papillon Bloemiste**, Rietbokgebou 6, Vanderbijlpark, voornemens is om genoemde saak, binne 30 dae na die laaste verskyning van hierdie kennisgewing te verkoop en oor te dra aan **Elizabeth Aletta Bothma** wat daarna die besigheid onder dieselfde naam by dieselfde adres vir haar eie rekening en voordeel voortsit.

Lourens Van der Westhuizen, Santrustgebou, Posbus 1138, Vanderbijlpark.

KENNISGEWING

Kennis geskied hiermee ooreenkomstig artikel 34 van Wet No. 24 van 1936, soos gewysig, dat **Mathiam Johannes Jansen van Rensburg** van voornemens is om die besigheid bekend as **Video 80** te verkoop en oor te dra aan **Joseph Sandilands Liebenberg** wat die besigheid sal voortsit by dieselfde adres en onder dieselfde naam vir sy uitsluitlike voordeel en rekening vanaf die 12de dag van Mei 1984.

Gedateer te Vereeniging hierdie 15de dag van Mei 1984.

D. J. Malan & Hoffman, Cicerogebou, Lesliestraat 14, Posbus 415, Vereeniging, 1930.

SALE OF BUSINESS

Notice is hereby given in terms of section 34 of Act No. 24 of 1936, as amended, that it is the intention of **Dulcie Joyce Myburgh and Vera Fashions (Pty) Ltd**, carrying on business as a general dealer (ladies clothing) at 193a Esselen Street, Sunnyside, Pretoria, under the style of **Vera Fashions** to dispose of the said business, together with all the assets thereof after the expiration of a period of 30 (thirty) days from the date of the 1st publication hereof to **Vierentia Leenad Beukes and Arnold Alexis Beukes**, who will thereafter carry on the said business at the same address and under the same style for their own account and benefit.

F. J. de Klerk, Business Exchange (Pty) Ltd, Broker for the Parties, 904 Louis Pasteur Building, 374 Schoeman Street, Pretoria, 25/5/84.

NOTICE OF SALE OF BUSINESS

Notice is hereby given in terms of section 34 of Act 24 of 1936 (as amended) that **G C I (Boston) (Proprietary) Limited** intends disposing of the business known as **Boston Filling Station** which is conducted at 1 Prinsloo Street, Pretoria, as a going concern with effect thirty (30) days after the last publication of this advertisement to **Freddy Hecht** who will thereafter conduct the business at the same address and under the same name for his own account.

R. E. Megaw, 416 Standard Bank Chambers, Church Square, Pretoria.

NOTICE OF SALE OF BUSINESS

Notice is hereby given in terms of section 34 (1) of Act No. 24 of 1936, as amended, that it is the intention of **Stratos Nicholas Esstathiou, Vasilis Charalambous Kampanellaris** and **Alexander Constantine Esstathiou** carrying on business as **Steers Fast Food** to dispose of the said business together with all the assets thereof as from the 1st May 1984 to **Anaspasios Tziatas** who will thereafter carry on the said business at the same address for his own account and benefit.

Michael J. Shneier, 1 Leromo House, 21 Rothsay Street, Benoni.

SALE OF BUSINESS

Notice is hereby given in terms of section 134 (1) of the Insolvency Act No. 24 of 1936 to interested parties and creditors of the intention of **L E J B (Proprietary) Limited, Annie Arenson (Proprietary) Limited** and **Percy Jankelowitz** carrying on business as **West Driefontein Supply Store** on Trading Site No. 8 on the farm Driefontein No. 113, Registration Division I.Q., Transvaal, to alienate the said business to **Alrode Outfitters (Proprietary) Limited** with effect from 30 days from the date of the last publication of this notice, from which date the said purchaser will carry on the said business under the same name and at the same address for its sole benefit and account.

J. B. Hugo & Cronje, Attorneys for the Parties, Allied House, Market Street, Krugersdorp.

NOTICE OF SALE

Please take notice that **Mrs S. Redelinghuys** has sold the business known as **Kardies Witbank Checkers**, trading at Shop 8, Checkers Centre, corner of Stevenson and Watermeyer Streets, Witbank, as a going concern to **Kardicor (Pty) Ltd**, 2 Baanbreker Avenue, Helderkruin, Rodepoort, who will continue with the business at the same address.

J. L. Matthews.

SALE OF BUSINESS

Notice is hereby given in terms of section 34 (1) of the Insolvency Act, No. 24 of 1936, as amended, that it is the intention of **Bruce Eric Heafield** trading under the name and style of the **Courier Restaurant**, 34 (a) Cradock Avenue, Rosebank being a certain restaurant business to dispose of his business together with all assets and goodwill thereof to **Richard Michael Gordon** and **Paul Ekou** who will carry on business for their account and benefit 30 days as from the date of publication hereof under the name **The Hot Tin Roof** at the same address.

Dated at Johannesburg this the 28th day of May 1984.

Edward Nathan & Friedland Inc., Attorney's for the Purchasers.

KENNISGEWING

Kennis geskied hiermee ooreenkomstig artikel 34 van Wet 24 van 1936 (soos gewysig) dat **Antonio Louis de Ponte** en **João de Sequeira** van voorneme is om die handelaarsbesigheid bekend as **Jack's Butchery** te Ermeloweg 78, Largo, Springs, te verkoop en oor te dra aan **Johannes Marthinus Greyling** wat die besigheid sal voortsit by dieselfde adres onder die naam **Jack's Butchery** vir sy uitsluitlike voordeel en rekening binne 30 (dertig) dae vanaf die laaste publikasie van hierdie kennisgewing.

A. P. Kilian, Derde Verdieping, Sanlamsentrum, Derde Straat, Posbus 674, Springs, 1560.

NOTICE OF SALE OF BUSINESS

Be pleased to take notice that **Zee Zee Curtains (Proprietary) Limited** trading as **Zee Zee Curtains** at 3rd Floor, Purchaser Place, 187 Market Street, Johannesburg has sold the business as a going concern to **Kenneth Brian Muir** as a nominee for a company about to be formed, with effect from 31 (thirty one) days from the last publication hereof, from which date the said **Kenneth Brian Muir** as a nominee for a company about to be formed, will conduct the said business at the same address.

Morgan, Meyersohn & Scalco, Attorneys for Seller, P.O. Box 31867, Braamfontein, 2017.

NOTICE OF SALE

Be pleased to take notice that the business known as **Malvern Video One** situate at 583 Jules Street, Malvern, Johannesburg, has been sold by **Carlos Alberto Sequeira de Matos** to **Dinis Pereira dos Santos** from the effective date between the parties, being the 31st day of May 1984. Insofar as creditors are concerned, the sale will take effect 31 (thirty one) days after the final publication hereof.

Aubrey S. Rabinowitz, Attorney for the Parties, 10th Floor, Delters Square, Kerk and Delters Streets, P.O. Box 4729, Johannesburg, 2000.

SALE OF BUSINESS

Notice is hereby given in terms of section 34 of Act No. 24 of 1936 as amended that **Brenda Matilda Elson** trading under the style and form of **Elmo Shop** situate at Shop No. 5, 30 Central Avenue, Eastleigh has sold the said business with all assets, goodwill fixtures and fittings to **Maurveen Cynthia Russell** who will carry on business at the same address and under the same name for her own benefit and account with effect from a date thirty (30) days after the last publication of this notice **Lionel Sher**, Attorneys for the Parties, **Eden Plaza**, 18 Van Riebeeck Avenue, Edenvale.

NOTICE OF SALE

Be pleased to take notice that the business known as **Samba Restaurant** situate at 312 Bree Street, Johannesburg, has been sold by **Adelino de Sousa** and **Honorio Gomes Roberto** to **Maria dos Anjos Rosa Pontes da Silva** from the effective date between the parties being the 7th May 1984. Insofar as creditors as concerned the sale will take effect 31 days after the last publication hereof.

Aubrey S. Rabinowitz, 10th Floor, Delters Square, Kerk and Delters Streets, Johannesburg.

NOTICE OF SALE OF BUSINESS IN TERMS OF SECTION 34 OF ACT 24 OF 1936

Notice is hereby given in terms of section 34 of Act 24 of 1936, as amended, that the business carried on by **Pieter Christoffel Heydenrych** under the name and style of **The Bargain Villa**, 52 West Street, Kempton Park has been sold to **Cornelius Petrus Lourens** and **Jasper Lodewicus Jansen van Rensburg** who will conduct the said business for his own account with effect from thirty (30) days after the last publication of this advertisement.

G. G. Cronje, for Jacobs Van Rensburg & Schoon, 101 Myrtle Court, West Street, Kempton Park.

NOTICE OF SALE OF BUSINESS IN TERMS OF SECTION 34 OF ACT 24 OF 1936

Notice is hereby given in terms of section 34 of Act 24 of 1936, as amended, that the business carried on by **Jan Dries Burger** under the name and style of **Fairwinds Caravans Park** at Plot 60 Northom Home Estates, has been sold to **Jose Ferreira dos Reis Amaral** who will conduct the said business for his own account with effect from thirty (30) days after the last publication of this advertisement.

D. L. Schoon, for Jacobs Van Rensburg & Schoon, 101 Myrtle Court, West Street, Kempton Park.

Pretoria. (2) Rene Hsas. (3) Hairdressers, Chez Mari, St Georges Building, Roderick Street, Lynnwood, Pretoria. (4) Sale. (5) Johanne Elizabeth Boshoff. (6)—. (7) Adams & Adams, P.O. Box 1014, Pretoria, 22 May 1984.

Verwoerdburg. (2) Elias Albertus de Kock en Glodina Maria Smith. (3) Die Hoekie, Wierda Park, Verwoerdburg. (4) Verkoop. (5) Willem Jacobus Loots. (6)—. (7) Meintjes & Petzer, Sentrakorgebou 103, Pretoriusstraat, Pretoria.

Pretoria. (2) Stefanus Francois Saunders. (3) Dameshaarkappers, Salon Edlen, Robynstraat 67, Waverley, Pretoria. (4) Verkoop. (5) Bealah Miles. (6)—. (7) Meintjes & Petzer, Sentrakorgebou 103, Pretoriusstraat, Pretoria.

Boksburg. (2) Agostinho Corte. (3) LM Café, 68 Leeupoort Street, Boksburg. (4) Sale. (5) Manuel Francisco Ribeiro and Severino Araujo Goncalves. (6)—. (7) Stupel & Berman, P.O. Box 436, Germiston, 1401.

Middelburg. (2) Maxine Jacobus Alwyn Knowles. (3) Africana Winkel. (4) Verkoop, 1 Junie 1984. (5) Gertruida Christine Lombard. (6)—. (7) Brandmuller, Du Preez & Van den Berg, Posbus 59, Middelburg, 1050.

Pretoria. (2) Robert Allison en Udo Ablinger. (3) New Idea Panelbeaters, 1213 Pretoriaweg, Booyens, Pretoria. (4) Verandering van vennootskap. (5) Udo Ablinger en Richard Mansell. (6)—. (7) Meintjes & Petzer, Sentrakorgebou 103, Pretoriusstraat, Pretoria.

Kempton Park. (2) George Alexander Craig. (3) Gordons Motors. (4) Sale. (5) Edrich Auto Sales Agencies (Pty) Ltd. (6)—. (7) Botha Massyn & McKenzie.

Machadodorp. (2) Colin Aston Shirley. (3) Droogskoonmaker, U & S Dry Cleaners, Resterende gedeelte van Erf 374, Voortrekker Street, Machadodorp. (4) Verkoop. (5) Jan Harm Steenkamp. (6)—. (7) Victor D. Weimar & Seuns, Prokureurs vir die Partye, Vermootenstraat, Posbus 11, Belfast.

Odendaalsrus. (2) Lionel Rodrigues da Franca Barbosa en Jose D'Abreu dos Ramos. (3) Turbo Café, Erf 1314, Erleigh Boulevard 85, Odendaalsrus. (4) Ontbinding van vennootskap. (5) Lionel Rodrigues da Franca Barbosa. (6)—. (7) Wessels & Smith, Posbus 721, Welkom.

Pretoria. (2) Estelle Sarah Orlin, born Finkelstein. (3) Fashion Creations (Pty) Ltd, Shop 2, Koedoe Arcade, 236 Pretorius Street, Pretoria. (4) Sale. (5) Angela Elizabeth Heinz, born Jordan. (6)—. (7) Moosa, Omar & Kollapen, Attorneys, P.O. Box 3719, Pretoria, 0001.

Bothaville. (2) W. J. Buys & Associates Incorporated. (3) Bothaville Pharmacy, Erf 106, President Street, Bothaville. (4) Sale. (5) Francois Petrus van der Linde. (6)—. (7) Joffe & Kobrin, P.O. Box 52689, Saxonwold, 2132.

Johannesburg. (2) K. Zafropoulos. (3) Ponte Pantry, Shop 1, Ponte City Building, Lily Avenue, Berea, Johannesburg. (4) Sale. (5) H. Dermitzakis. (6)—. (7) J. Tsalavoutas, P.O. Box 9370, Johannesburg, 2000.

Johannesburg. (2) Mrs Ho Su King. (3) Hi-Lite Fish and Chips, 67 Troye Street, Johannesburg. (4) Sale. (5) Manny Abreu. (6) I and Me Fish and Chips. (7) Alec Loo, 24 Rifle Range Court, 261 Rifle Range Road, Haddon, Johannesburg.

Alberton. (2) Michael Leisher and Claudette Rahme. (3) Mike's Coin Operated Laundrette, Shop 4, 39 Penzance Street, New Redruth, Alberton. (4) Sale. (5) George Leong. (6)—. (7) G. Leong, 62 Observatory Avenue, Observatory, 2198.

Pretoria. (2) Ian Michael Klevansky. (3) General dealer, Play and Learn, Shop 4b, The Village, Esselen Street, Sunnyside, Pretoria. (4) Sale. (5) Rusticus Francois du Preez. (6)—. (7) Friedland, Hart & Partners, 212 Van der Stel Buildings, 179 Pretorius Street, Pretoria.

Rodepoort. (2) Aगत Goesny Abader. (3) Julies Muslim Butchery, Shop 6, Ennerdale Shopping Centre, Ennerdale, Rodepoort. (4) Sale. (5) Harold Joseph Raymond. (6)—. (7) Dangor-Chunilal, Attorneys, P.O. Box 127, Lenasia, 1820.

Johannesburg. (2) Stefan Brian Joselowitz. (3) Wimpy Bar, Rand Bank Centre, corner of Melle and Jorissen Streets, Braamfontein, Johannesburg. (4) Sale. (5) Allen Jerome Girmun. (6) Lucio's. (7) Nat Bregman, P.O. Box 1975, Johannesburg.

Johannesburg. (2) Random Books (Pty) Ltd. (3) Random Books, 73 Rissik Street, Johannesburg. (4) Sale. (5) G. J. Martinolli and M. M. Martinolli. (6)—. (7) Hershel Estates, P.O. Box 3148, Johannesburg, 2000.

Germiston. (2) Stamatiki Felekis. (3) Wadeville Hardware Centre, corner of Osborne and Rendell Streets, Wadeville, Germiston. (4) Sale. (5) Bernard Myers. (6)—. (7) Kokkoris & Christelis, 11th Floor, Diamond Corner, 68 Eloff Street, P.O. Box 411, Johannesburg.

Johannesburg. (2) Michael Grasso. (3) Miami Fast Foods, Italic Centre, 107 Eloff Street, Johannesburg. (4) Sale. (5) Polychronia Hatzipolychronis. (6)—. (7) Moodie & Robertson, Eighth Floor, African Life Centre, 111 Commissioner Street, Johannesburg.

Johannesburg. (2) Maximino Moreira. (3) New Heriot Restaurant and Butchery, 526 Main Reef Road, Denver, Johannesburg. (4) Sale. (5) Konstantinos Hatzioannios and Vassilios Lambropoulos. (6)—. (7) E. Salgado, Attorney, 2041 Sanlamsentrum, Jeppe Street, Johannesburg.

Johannesburg. (2) Mangen Agencies (Pty) Ltd with sole director Manfred Girawski. (3) Wimpy Bar, 49 Pretoria Street, Hillbrow, Johannesburg. (4) Sale. (5) Mrs Rosalba Cicoghani and Carlo Donofrio. (6)—. (7) Garnett Lemkus Business Brokers, Third Floor, Corner Point Building, corner of Claim and Pretorius Streets, Hillbrow.

Doornfontein. (2) Stanley Hock Shan. (3) Mays Cash Store, 32 Buxton Street, Doornfontein, Johannesburg. (4) Sale. (5) Edward Ahhon. (6)—. (7) Sapire, Jacobson & Creswick, 1-9 Symons Buildings, 174 Central Avenue, Mayfair, Johannesburg, 2092.

Johannesburg. (2) Bridghlal Badal. (3) Parabellum Take Away, 380 Main Reef Road, Denver, Johannesburg. (4) Sale. (5) Giampiro Inches. (6)—. (7) Camdon's Realty (Pty) Ltd, Camdon's Business Brokers, P.O. Box 781221, Sandon, 2146.

Johannesburg. (2) George Martin Schwab. (3) Jackpot Discounter, Shop 15, Sheckers Centre, Bertrams, Johannesburg. (4) Sale. (5) Erna Brigitta Sebek. (6) S and H Paint and Hardware. (7) Gilbert Estates, 72 Leonard Street, Kenilworth, 2190; P.O. Box 74120, Turffontein, 2140.

Pretoria. (2) Maria Christina Zwahlen. (3) Touch of Glass, Burlington Arcade, Church Street, Pretoria. (4) Sale. (5) Kelly Manson. (6) Home Hair Care Centre by Kelly. (7) E. de W. du Plessis, Third Floor, Tudor Chambers, Church Street, Pretoria.

Pretoria. (2) Mark Owen Lockwood and Mrs Helen Ann Ratham. (3) Styles-Inn, Shop 24, Lynnwood Ridge Shopping Centre, Pretoria. (4) Sale. (5) George Noel Ferguson. (6) André for Menswear. (7) L. F. Smuts, Second Floor, Homes Trust Building, 224 Pretorius Street, Pretoria.

Pretoria. (2) Christos Droganis. (3) Kafee, Roodeplaatdam Kafee, Gedeelte 53, Zeekoegat. (4) Verkoop. (5) Elias Cipriano dos Santos en Lionel Cipriano dos Santos. (6)—. (7) D. H. Pols, Centenarygebou 314, Bureaulaan, Pretoria.

Johannesburg. (2) Rasiklal Kanjee. (3) Laxmi Wholesalers, 4 Concord Place, Lenasia. (4) Alienation. (5) Nagin's Supermarket (Pty) Ltd. (6)—. (7) Alec Oshry & Cohen, Sixth Floor, Nedbank Mall, corner of Smal and Commissioner Streets, Johannesburg.

KAAP • CAPE

KENNISGEWING VAN VERKOOP VAN HANDELAARSAAK OOREENKOMSTIG ARTIKEL 34 VAN WET 24 VAN 1936

Kennis geskied hiermee, ooreenkomstig artikel 34 van Wet No. 24 van 1936, soos gewysig, dat **Pierre Louis le Roux en Hester Anna Johanna Theron** van voorneme is om die slaghuis bekend as **Sentra Vleis** van Vasco Boulevard 5, Vasco te verkoop en oor te dra aan **Sidney van der Berg**, wat die saak sal voortsit by dieselfde adres en onder die naam **Boulevard Vleismark** vir die uitsluitlike voordeel van haar rekening vanaf 24 April 1984.

Gedateer te Goodwood op hede die 15de dag van Mei 1984.

Heyns, Strauss & Visagie, Prokureurs vir Partye, Voortrekkerweg 70, Goodwood.

VERVREEMDING VAN BESIGHEID

Gejiewe kennis te neem in terme van artikel 34 (1) van Wet No. 24 van 1936, soos gewysig, dat **Johannes Heronimus Brink** wat handeldryf onder die naam **Haskings Wholesale and Distributors**, Boogstraat, Industriële Gebied, Humansdorp van voornemens is om die voormelde besigheid tesame met alle toebehore en klandisiewaarde te vervoer aan **Willem Adriaan Andreas Deetlefs** wat sal handeldryf onder die naam **Haskings Wholesale and Distributors** by gemelde adres. Hierdie vervoerding sal effektief wees op die 1ste Junie 1984.

C. W. Malan & Kie., Prokureurs vir die Partye, Hoofstraat 52, Humansdorp, 6300.

NOTICE OF SALE

Notice is hereby given in terms of section 34 of Act 24 of 1936, as amended, that the business carried on by **Lawrence Eric Wright and Basil Ernest Tessoroff** under the name and style of **Lesley's** at 4 Chamberlain Road, East London, has been sold to **Cleio Portela and Telo Gomes Meneses** who will conduct the said business for his own account with effect from thirty (30) days after the last publication of this advertisement.

Drake, Flemmer, Orsmond & Vermaak, Attorneys for Parties, 15 Terminus Street, East London.

NOTICE OF SALE OF BUSINESS

Notice is hereby given in terms of section 34 of Act 24 of 1936 (as amended) that the **Durbanville Non-Denominational Coffee Shop Association** intends disposing of his business known as **The Fountain**, which is conducted at Shop No. 26, Town Centre, Durbanville, as a going concern with effect from 30th May 1984 to **E. T. Palva** who will thereafter conduct the business at the same address and under the same name for his own account.

KENNISGEWING VAN VERKOOP VAN SAKE-ONDERNEMING

Kennis geskied hiermee kragtens artikel 34 (1) van die Insolvensiewet, No. 24 van 1936, dat **Neville Gordon Long** wat sake doen onder die naam **Oudekraal Restaurant** te Kerkstraat 48, Worcester van voorneme is om genoemde sake-onderneming as 'n lopende saak te verkoop aan **Dion Galgher en Carel Frederick Hendrik Meiring** wat genoemde sake-onderneming onder dieselfde naam vir hulle eie rekening en voordeel sal bedryf vanaf 9 Julie 1984.

Gedateer te Worcester op hierdie 25ste dag van Mei 1984.

Maritz Murray & Fourie, Partye se Prokureurs, Adderleystraat 34, Posbus 25, Worcester, 6850.

SALE OF BUSINESS

Notice is hereby given in terms of section 34 of the Insolvency Act, No. 24 of 1936, as amended, that it is the intention of **William James Woodland**, carrying on business under the style of **Wetton Coach Works**, at Walnut Road, to dispose of such business to **Roy Williams**, who will carry on business at the same address and under the same name for his own account and benefit.

Dated at Cape Town this 12th day of March, 1984.

Hermanus. (2) Willem Christiaan Botha. (3) Willem's Superette, Patersonstraat, Hermanus. (4) Vervreemding. (5) Van Zyl Steyn. (6)—. (7) Guthrie & Theron, Posbus 37, Hermanus, 15 Mei 1984.

Cape Town. (2) Windjammer (Pty) Ltd. (3) Bottle store, Bingo Liquors, 295-297 Long Street, situate on remaining extent of Erf 4023, Cape Town. (4) Sale. (5) David Johannes van Lill. (6)—. (7) Friedland Hart & Partners, P.O. Box 1003, Pretoria, 0001.

Plettenberg Bay. (2) Stephanus Philippus Fouché. (3) Plett Cleanette, The Building Centre, Erf 987, Plettenberg Bay. (4) Sale. (5) Raymond Ernest Lawrence. (6)—. (7) Hutchinson, Theron & Robin, P.O. Box 170, Plettenberg Bay, 6600.

Hermanus. (2) Roy Cecil Lamohr. (3) Stanford Shopping Centre, Skoolstraat, Stanford. (4) Oorname. (5) Abdurahman Brey. (6)—. (7) Guthrie & Theron, Posbus 37, Hermanus, 7200, 22 Mei 1984.

Port Elizabeth. (2) Wessel Johannes Coleske. (3) Smith's Butchery, 55 Westbourne Road, Port Elizabeth. (4) Sale, 1 July 1984. (5) Joseph Leonard Clemons. (6)—. (7) Ludi Strydom & Co., 597 Main Street, Port Elizabeth, 25/5/84.

Lansdowne. (2) Teunis Rozenboom. (3) Reinaert Clothing, 15 Blomvlei Road, Lansdowne. (4) Sale. (5) Danco Knitting Mills S.A. (Pty) Ltd. (6)—. (7) Asherson & Asherson, P.O. Box 2219, Cape Town.

Wynberg. (2) Elizabeth Anne Klarie, married out of community of property to Peter Kenneth Klarie and Lannice Snyman, married out of community of property to Michael Johann Snyman. (3) Chardonnay Restaurant, Village Square, Main Road, Hout Bay. (4) Sale. (5) Poalo Oreste Gueli. (6)—. (7) Asherson & Asherson, Ashersons Chambers, Plein Street, Cape Town.

Port Elizabeth. (2) Anthony Michael Tomlin. (3) Duffey's Take Aways, Café, 3 Harmonie Building, Graham Street, North End, Port Elizabeth. (4) Sale. (5) Anthony Otto Butlion. (6)—. (7) Wilke, Weiss & Van Rooyen, 420 Golden Mile Centre, Hoof Street, North End, Port Elizabeth.

Hartswater. (2) Petrus Gabriel Visser Gerber. (3) Harts Toyota, D. F. Malanstraat, Hartswater. (4) Verkoop, 9 Julie 1984. (5) Rooikop Visser (Edms.) Bpk., Pk. Tadcaster. (6)—. (7) Alf Bennett, Prokureur, Posbus 524, Hartswater, 30 Mei 1984.

Cape Town. (2) B. Ginsberg (Pty) Ltd. (3) B. Ginsberg (Pty) Ltd, 12b Auckland Street, Paarden Eiland, Cape Town. (4) Sale, 2 July 1984. (5) Natal Tea Packers (Pty) Ltd. (6)—. (7) Deneys Reitz, P.O. Box 784903, Sandton.

NATAL

Uvongo. (2) Jacobus Johannes Wessels. (3) Supermarket, St Michaels Supermarket, Marine Drive, Lot 2369, Uvongo. (4) Sale. (5) Shirley Ursula Hooper. (6)—. (7) T. S. Kalil & Company, Second Floor, Oribi, Marine Drive, P.O. Box 582, Margate, 4275.

Pietermaritzburg. (2) G.O.M. (Pty) Ltd. (3) G.O.M. Business Machines, 165 Longmarket Street, Pietermaritzburg, 3201. (4) Sale. (5) John Peter Rozwadowski. (6)—. (7) Cecil Nathan, Beattie & Company, P.O. Box 68, Pietermaritzburg, 3200, 23 May 1984.

Shelly Beach. (2) Leslie Gordon Kalil. (3) General dealer, Cuddles Baby Boutique, Shop 3, Lot 996, Shelly Beach. (4) Sale. (5) Yvonne Elisabeth Maria Steenmans, Henrica Maria Catharina Steenmans and Johannes Hendricus Steenmans. (6)—. (7) T. S. Kalil & Company, Second Floor Oribi, Marine Drive, P.O. Box 582, Margate, 4275.

Empangeni. (2) Bennie Good. (3) Empangeni Refrigeration, 2 Third Street, Kuleka, Empangeni Rail. (4) Sale. (5) Anthony Friedrichs. (6)—. (7) Chris van der Merwe Behrmann & Co., P.O. Box 857, Empangeni, 3880.

Mtubatuba. (2) Martha Cornelia Catharina Christina Nel. (3) Salon Rene, Mtubatuba, District of Hlabisa. (4) Sale, 30 April 1984. (5) Rosemary Jean Stone. (6)—. (7) Roger Wiehahn & Company, P.O. Box 164, Mtubatuba, 3935.

New Germany. (2) Truck Accident Repair Centre (Pty) Ltd. (3) Panel beaters and spray painters, 25 Chelsea Avenue, New Germany. (4) Sale, 1 June 1984. (5) J F Hermans Body Works (Pinetown) (Pty) Ltd. (6)—. (7) J. H. Nicolson Stiller & Geshen, P.O. Box 641, Durban, 4000.

Pinetown. (2) L. C. C. Hoffmann and M. B. Hoffmann. (3) Forklift Specialists, Elecmann Services, 1 Myrtle Road, Pinetown. (4) Sale. (5) Rene Willem Schreiner. (6)—. (7)—.

Botha's Hill. (2) Robert Brian Tomlinson. (3) Botha's Hill Café and Bhansela Store, Comestible Buildings, 115 Old Main Road, Botha's Hill. (4) Sale of share in partnership. (5) Karei van Bakel. (6)—. (7) Halse Havemann Lloyd & Ferreira, Second Floor, Stannic House, 15 Dales Avenue, Pinetown, P.O. Box 23, Pinetown.

NOTICE OF INTENTION TO SELL BUSINESS [SECTION 34 (1) OF ACT No. 24 OF 1936]

Take notice that **James Edward Jacobs** carrying on business in partnership with **Bernardus Johannes du Toit** under the name of **D N Plumbing** at Office No. 17, Old Mutual Centre, Newcastle, intends to alienate his one-half share in the said business to the said **Bernardus Johannes du Toit** upon the expiration of 30 (thirty) days after the publication of the last advertisement in terms of section 34 (1) of Act No. 24 of 1936, from which date the said **Bernardus Johannes du Toit**, will carry on the said business for his own account.

Shuttleworth & Holborn, Attorneys for the Parties, N B S Building, Scott Street, Newcastle.

SALE OF BUSINESS

Notice is hereby given in terms of section 34 (1) of the Insolvency Act, 24 of 1936 that **Leslie Ronald Reader** carrying on business as **Readers Book Exchange** at 103 Kingsway, Warner Beach, intends to dispose of the said business after a period of thirty (30) days from the last publication of this notice to **Mrs Brenda Lynne O'Sullivan** who will thereafter carry on business for her own account as **Readers Book Exchange**.

Dated at Amanzimtoti this 30th day of April 1984.

I.F.S. Business Brokers, Amanzimtoti.

ALIENATION OF BUSINESS

Notice is hereby given in terms of section 34 (1) of the Insolvency Act, Act 24 of 1936, as amended, that it is the intention of **John Kingsley Rautenbach** carrying on business as **Personnel Consultants**, at 1st Floor, Vareco House, Masonic Grove, Durban, under the style of **Profile Personnel** to dispose of the said business together with all the assets thereof as from the 1st day of February 1984 to **Bruce David Soutar** who will thereafter carry on the said business at the same address for his own account and benefit.

Berkowitz, Kirkel, Cohen Inc., 15th Floor, Durban Bay House, Smith Street, Durban.

ALIENATION OF BUSINESS

Notice is hereby given in terms of section 34 (1) of the Insolvency Act, Act 24 of 1936, as amended, that it is the intention of **Charles Lesley Shirken** carrying on business as a second channel video business at 24 Ivy Road, Durban, under the style of **Dubelell Video Services** to dispose of the said business together with all the assets thereof as from the 1st June 1984 to **Esmé Jean le Breton Devieuville** and **Pierre Andreas Smit** who will thereafter carry on the said business at the same address for their own account and benefit.

Berkowitz, Kirkel, Cohen Inc., Seller's Attorneys, 15th Floor, Durban Bay House, Smith Street, Durban.

ORANJE-VRYSTAAT • ORANGE FREE STATE

Welkom. (2) Luis Jacques Josselin Cretien. (3) St Helena Watchmakers and Jewellers, 20b Bracken Street, St Helena, Welkom. (4) Sale. (5) Sharon Smith, married out of community of property to Ivor Noel Smith with the exclusion of the marital power. (6) —. (7) Wessels & Smith, P.O. Box 721, Welkom, 21 May 1984.

Welkom. (2) Antonio Silvano Mateus. (3) Tony's Café, Erf 697, Tugela Sirkel 6a, St Helena, Welkom. (4) Verkoop. (5) Raimundo Gonzalves da Costa. (6) —. (7) Wessels & Smith, Posbus 721, Welkom, 9459, 21 Mei 1984.

MAATSKAPPYKENNISGEWINGS • COMPANY NOTICES**TRANSVAAL****GEOFLIN HOLDINGS (PROPRIETARY) LIMITED**

REGISTRATION No. 51/02696/07

MASTERS REFERENCE No. T525/84

VOLUNTARY WINDING-UP

[In terms of Section 356 (2) (b) of the Companies Act, 1973]

At a General Meeting of shareholders held on the 29th February 1984 it was resolved that the company be placed into Members' Voluntary Liquidation.

It was further resolved that Mr Abraham Levenstein of Levenstein and Partners, Suite 102, Legal & General Chambers, Cor. Louis Botha Avenue & 6th Street, Orange Grove, Johannesburg, 2192, be appointed Liquidator for the purpose of the winding-up of the company.

TAURUS PROPERTIES (PROPRIETARY) LIMITED

REGISTRATION No. 51/02695/07

MASTERS REFERENCE No. T526/84

VOLUNTARY WINDING-UP

[In terms of Section 356 (2) (b) of the Companies Act, 1973]

At a General Meeting of shareholders held on the 29th February 1984 it was resolved that the company be placed into Members' Voluntary Liquidation.

It was further resolved that Mr Abraham Levenstein of Levenstein and Partners, Suite 102, Legal & General Chambers, Cor. Louis Botha Avenue & 6th Street, Orange Grove, Johannesburg, 2192, be appointed Liquidator for the purpose of the winding-up of the company.

ROOSVIER (EIENDOMS) BEPERK

REF. No. T431/84

VOLUNTARY WINDING UP

Notice is hereby given that the following special resolution was passed at an extraordinary general meeting of shareholders on the 17th February 1984:

That the company be wound up voluntarily and that it be placed in liquidation subject to the following provisions and conditions:

- (a) The winding up be a members' voluntary winding up in accordance with section 349 of the Companies Act, 1973, as amended.
- (b) Brian Alistair Selvan be nominated liquidator and his remuneration be R800.
- (c) The liquidator be not required to furnish security in terms of section 375 (1) of the Act.
- (d) In terms of section 422 (1) (b) of the Act the liquidator be authorised to dispose of the books and papers of the company and of its winding up immediately after its dissolution.
- (e) In terms of section 350 (b) (ii) of the Act the director be not required to furnish security to the Master.

Selvan, Dick, Gillan and Company, P.O. Box 107, Springs, 1560.

ABERDARE CABLES AFRICA LIMITED

(Incorporated in the Republic of South Africa)

DECLARATION OF DIVIDEND

Notice is hereby given that 5,5 % Preference Dividend No. 75 of 5,5 cents per share has been declared payable to holders registered in the books of the company at the close of business on 8th June 1984.

For this purpose, the 5,5 % Preference Share Register of the company will be closed from 9th June 1984 to 17th June 1984, both days inclusive.

Dividend warrants will be posted to shareholders on or about 29th June 1984.

Non-Resident Shareholders' Tax will be deducted from the dividends of Shareholders whose registered addresses are outside the Republic of South Africa.

By Order of the Board.—R. A. Seymour, Secretary.

DELSWA LIMITED

(Incorporated in the Republic of South Africa)

DECLARATION OF DIVIDEND

Notice is hereby given that 5,5 % Preference Dividend No. 73 of 5,5 cents per share has been declared payable to holders registered in the books of the company at the close of business on 8th June 1984.

For this purpose, the 5,5 % Preference Share Register of the company will be closed from 9th June 1984 to 17th June 1984, both days inclusive.

Dividend warrants will be posted to shareholders on or about 30th June 1984.

Non-Resident Shareholders' Tax will be deducted from the dividends of Shareholders whose registered addresses are outside the Republic of South Africa.

By Order of the Board.—N. R. Pechey, Secretary.

PREMIER GROUP HOLDINGS LIMITED

(Incorporated in the Republic of South Africa)

DECLARATION OF DIVIDEND

Notice is hereby given that Ordinary Dividend No. 142 of 54 cents per share has been declared payable to holders registered in the books of the company at the close of business on 22nd June 1984.

For this purpose, the Ordinary Share Register of the company will be closed from 23rd June 1984 to 8th July 1984, both days inclusive.

Dividend warrants will be posted to shareholders on or about 23rd July 1984.

Non-Resident Shareholders' Tax will be deducted from the dividends of Shareholders whose registered addresses are outside the Republic of South Africa.

By Order of the Board.—Mrs J. A. Elgie, Group Secretary.

CASH DISCOUNT SERVICES (EIENDOMS) BEPERK

No. T680/84

(In vrywillige likwidasie)

Alle belanghebbende partye word hierby in kennis gestel dat bogenoemde maatskappy kragtens 'n Spesiale Besluit ingevolge Artikel 349 van die Maatskappywet deur aandeelhouers onder vrywillige likwidasie geplaas is. Mnr. W. H. Lloyd van Posbus 50571, Randburg, 2125, is as likwidateur aangestel.

PREMIER GROUP HOLDINGS LIMITED

(Incorporated in the Republic of South Africa)

DECLARATION OF DIVIDEND

Notice is hereby given that 5,5 % Preference Dividend No. 30 of 5,5 cents per share has been declared payable to holders registered in the books of the company at the close of business on 22nd June 1984.

For this purpose, the 5,5 % Preference Share Register of the company will be closed from 23rd June 1984 to 29th June 1984, both days inclusive.

Dividend warrants will be posted to shareholders on or about 31st July 1984.

Non-Resident Shareholders' Tax will be deducted from the dividends of Shareholders whose registered addresses are outside the Republic of South Africa.

By Order of the Board.—Mrs J. A. Elgie, Group Company Secretary.

VIERFONTEIN COLLIERY LIMITED

(Incorporated in the Republic of South Africa)

DIVIDEND No. 60

CLOSING OF REGISTERS

For the purpose of payment of the abovementioned dividend payable to shareholders registered in the books of the company at the close of business on June 15th 1984, the transfer registers and registers of members will be closed from June 16th 1984 to July 1st 1984, both days inclusive.

By Order of the Board.—Anglo American Corporation of South Africa Limited, Secretaries, per A. H. J. Millenaar, Senior Divisional Secretary.
Registered office: 44 Main Street, Johannesburg, 2001.

OK BAZAARS (1929) LIMITED

NOTICE TO HOLDERS OF 11,4 % A UNSECURED DEBENTURES, 1993/97, and 11,2 % B UNSECURED DEBENTURES, 1989/91

INTEREST PAYMENT No. 8

Notice is hereby given that an interest payment for the six months ending 30th June 1984 has been declared payable on 30th June 1984 to holders registered in the books of the Company at the close of business on 15th June 1984.

For this purpose, the Debenture Stock Registers of the Company will be closed from 16th to 24th June 1984, both days inclusive, and interest warrants will be posted to stockholders on or about 29th June 1984.

By Order of the Board.—J. B. Parnall, Secretary.

OK BAZAARS (1929) LIMITED

NOTICE TO HOLDERS OF 13,5 % UNSECURED DEBENTURES, 1988/1995

INTEREST PAYMENT No. 16

Notice is hereby given that an interest payment for the six months ending 30th June 1984 has been declared payable on 30th June 1984 to holders registered in the books of the Company at the close of business on 15th June 1984.

For this purpose, the Debenture Stock Register of the Company will be closed from 16th to 24th June 1984, both days inclusive, and interest warrants will be posted to stockholders on or about 29th June 1984.

By Order of the Board.—J. B. Parnall, Secretary.

O.K. BAZAARS (1929) LIMITED

(Incorporated in the Republic of South Africa)

NOTICE OF CLOSURE OF REGISTER

Notice is hereby given that the 7,5 % Loan Stock Register of the Company will be closed from 9th June 1984 to the 30th June 1984, both days inclusive, for the purpose of—

- (1) the thirteenth 5 % redemption of the Loan Stock; and
- (2) calculation of the half-yearly interest payment;

both items falling due for payment on the 30th June 1984 to stockholders registered at the close of business on the 8th June 1984.

Non-Resident Tax at the rate of 10 % will be deducted from interest where applicable.

By Order of the Board.—J. B. Parnall, Secretary.

ACEROLA (EIENDOMS) BEPERK

VRYWILLIGE LIKWIDASIE DEUR LEDE

Kennis word kragtens Artikel 356 (2) (b) van die Maatskappywet, 1973, soos gewysig, hiermee gegee dat op 'n algemene vergadering van aandeelhouders gehou op 18 Januarie 1984 is dit spesiaal besluit dat—

- (1) die maatskappy vrywillig gelikwieder word kragtens Artikel 349 van die Maatskappywet, 1973;
- (2) William Keith Hunter Scott, van Stadsentrum 634, Pretoriusstraat, Pretoria, as likwidaat aangestel word.

Brink Roos & Du Toit, Posbus 1267, Pretoria, 0001.

HUMANSTRAAT BELEGGINGS (EIENDOMS) BEPERK

VRYWILLIGE LIKWIDASIE DEUR LEDE

Kennis word kragtens Artikel 356 (2) (b) van die Maatskappywet, 1973, soos gewysig, hiermee gegee dat op 'n algemene vergadering van aandeelhouders gehou op 18 Januarie 1984 is dit spesiaal besluit dat—

- (1) die maatskappy vrywillig gelikwieder word kragtens Artikel 349 van die Maatskappywet, 1973;
- (2) William Keith Hunter Scott, van Stadsentrum 634, Pretoriusstraat, Pretoria, as likwidaat aangestel word.

Brink Roos & Du Toit, Posbus 1267, Pretoria, 0001.

JOHANNESBURG CONSOLIDATED INVESTMENT COMPANY, LIMITED

(Incorporated in the Republic of South Africa)

PREFERENCE DIVIDENDS

Preference dividends No. 13 have been declared and are payable to holders of the redeemable cumulative preference shares registered in the books of the company at the close of business on 15th June 1984.

Dividends No. 13 are payable in respect of the half year ending 30th June 1984 at the rates per share shown below:

Fixed rate redeemable cumulative preference shares.....	11,25 cents per annum
Variable rate redeemable cumulative preference shares.....	13,00 cents per annum

Payment will be made in accordance with the requirements of the company's articles of association and in the currency of the Republic of South Africa. Dividend warrants will be posted from the head office of the company on or about 28th June 1984.

South African Non-Resident Shareholders' Tax at the rate of 14,86 per cent will be deducted from the dividends where applicable.

The registers of preference shareholders will be closed from 18th to 30th June 1984, both dates inclusive.

9,75 % UNSECURED NOTES

Notice is hereby given that the register of noteholders will be closed from 18th to 30th June 1984, both dates inclusive, in connection with the payment of interest due on 30th June 1984.

By Order of the Board.—M. J. Meyer, Secretary. *Head Office and Registered Office:* Consolidated Building, Cor Fox and Harrison Streets, Johannesburg, 2001; P.O. Box 590, Johannesburg, 2000, 29th May 1984.

ZINGEL'S INVESTMENTS (PROPRIETARY) LIMITED

Notice is hereby given pursuant to Section 356 (2) (b) of the Companies Act, 1973, that it was resolved by Special Resolution that Zingel's Investments (Proprietary) Limited be voluntarily liquidated as a Members' Voluntary Winding-up.—A. R. Bell and Company, Fifth Floor, 80 Marshall Street, Johannesburg.

HOËVELD SPARTAN (PROPRIETARY) LIMITED

Notice is hereby given in terms of Section 356 (2) (b) of the Companies Act, 1973, as amended, that the following resolution was passed pursuant to Section 349 of the Act, at a General Meeting of Shareholders of the Company, held for that purpose at Johannesburg on the 29th May 1984. That the Company be wound up voluntarily as a members' voluntary winding up; that Alan Brener of 1st Floor, Delvers Square, corner Kerk and Delvers Streets, Johannesburg, be appointed the Liquidator of the Company pursuant to Section 369 (1) of the said Act for the purposes of such winding up; that his remuneration be fixed at R5 000 and that he be exempted from furnishing security in terms of Section 375 of the said Act.

MAXWELL DEITCH (PROPRIETARY) LIMITED

Notice is hereby given, that the undernoted special resolutions were registered on 14th May, 1984, in terms of Section 200 of the Companies Act, 1973, as amended:

1. That the company be wound up voluntarily, such winding up to be a members' voluntary winding up.
 2. That John McClelland be and is hereby appointed liquidator of the company and at company expense he procures and furnishes security for the due performance of his duties, to the satisfaction of the Master of the Supreme Court in terms of Section 350 (1) (b) (i) of the Companies Act, 1973, as amended.
 3. That upon the final dissolution of the company the liquidator be, and he is hereby authorised and directed to destroy the books and records of the company or to procure their destruction in terms of Section 422 (1) (b) of the Companies Act, 1973, as amended.
 4. That the remuneration of the said liquidator shall be fixed at R800,00 (eight hundred rand) net of disbursements.
- G. C. Beaton & Co., P.O. Box 3262, Johannesburg, 2000.

BARMIN TRUST (PROPRIETARY) LIMITED

Notice is hereby given, that the undernoted special resolutions were registered on 14th May 1984 in terms of Section 200 of the Companies Act, 1973, as amended:

1. That the company be wound up voluntarily, such winding up to be a members' voluntary winding up.
 2. That John McClelland be and is hereby appointed liquidator of the company without obligation to furnish security for the due performance of his duties, should the furnishing of such security be dispensed with by the Master of the Supreme Court in terms of Section 350 (1) (b) (ii) of the Companies Act, 1973, as amended.
 3. That upon the final dissolution of the company the liquidator be, and he is hereby authorised and directed to destroy the books and records of the company or to procure their destruction in terms of Section 422 (1) (b) of the Companies Act, 1973, as amended.
 4. That the remuneration of the said liquidator shall be fixed at R5 000,00 (five thousand rand).
- G. C. Beaton & Co., P.O. Box 3262, Johannesburg, 2000.

TIGER OATS AND NATIONAL MILLING COMPANY, LIMITED

(Incorporated in the RSA)

CLOSING OF SHARE AND TRANSFER REGISTERS

Notice is hereby given that the appropriate transfer books and registers of preference shareholders will be closed from close of business on 8th June 1984 to close of business on 22nd June 1984, for the purpose of determining those holders of the 12,5 % fixed and the variable rate redeemable cumulative preference shares of 10 cents each entitled to participate in the first redemption of those shares on 29th June 1984, and entitled to receive the dividend payable on the redeemed shares for the period 1st January 1984 to 29th June 1984, and entitled to receive the dividend payable on those shares which are not being redeemed for the period 1st January 1984 to 30th June 1984. By Order of the Board.—H. Yudelowitz, Secretary. Registered office: 15th Floor, Wesbank House, 222 Smit Street, Johannesburg, 2001. Transfer secretaries: Consolidated Share Registrars Limited, Edura, 40 Commissioner Street, Johannesburg, 2001; P.O. Box 61051, Marshalltown, 2107.

KAAP - CAPE

GORDON PLACE ESTATES (PROPRIETARY) LIMITED

NOTICE OF SPECIAL RESOLUTION TO WIND UP VOLUNTARILY

Notice is hereby given pursuant to Section 356 (2) (b) of the Companies Act, 1973, that at an Extraordinary General Meeting of Shareholders held on the 1st March 1984, it was resolved as a Special Resolution that the Company would be wound up voluntarily as a members voluntary winding up, and that Leonard Fairbank Fleischer of Fidelity Bank Limited, Fidelity House, 190 Main Street, Port Elizabeth, be appointed Liquidator.

Fidelity Bank Limited, Secretaries.

DE BEERS CONSOLIDATED MINES LIMITED

(Incorporated in the Republic of South Africa)

NOTICE TO THE HOLDERS OF PREFERENCE SHARES

Notice is hereby given that, in connection with the preference dividends payable to shareholders registered on 29th June 1984, the preference share transfer registers and registers of members will be closed from 30th June 1984 to 13th July 1984, both days inclusive. By Order of the Board.—J. D. B. Engels, Secretary.

BALINTORE INVESTMENTS (PROPRIETARY) LIMITED

NOTICE OF SPECIAL RESOLUTION TO WIND UP VOLUNTARILY

[Pursuant to Section 349 (b) of the Companies Act, 1973]

Notice is hereby given that on 25th January 1984 at an extraordinary meeting of shareholders of the above company, the following Special Resolution was passed:

That the company be wound up voluntarily and that Johannes Nicolaas Ackermann be and is hereby appointed as Liquidator and that his remuneration be fixed at R500 and that he not be required to furnish security for the completion of his duties in terms of the Companies Act, 1973.

JAPONIKA (PROPRIETARY) LIMITED**(IN VOLUNTARY LIQUIDATION)****NOTICE OF SPECIAL RESOLUTION TO WIND UP VOLUNTARILY**

Notice is hereby given pursuant to Section 356 (2) (b) of the Companies Act, 1973, that a General Meeting of Shareholders of the Company held on March 30th 1984 the Shareholders passed a Special Resolution to wind up the Company by way of members voluntary winding up and that Abraham Benzion Hymie Margolis of Cape Town be appointed Liquidator of the Company. The Liquidator was exempt from furnishing security.

PALM SPRINGS HOLIDAY RESORT (PROPRIETARY) LIMITED**VOLUNTARY WINDING-UP**

Pursuant to Section 356 (2) (b) notice is hereby given that the following resolutions were passed in terms of Section 349 of the Companies Act, 1973, as amended, at a General Meeting of Shareholders of the Company held for that purpose at Port Shepstone on the 9th May 1984:

That the company be wound up voluntarily as a member's voluntary winding up.

That Mr Robin Stenhouse Tilney, 9th Floor, Murray & Stewart Centre, Terminus Street, East London, be and is hereby appointed liquidator of the company without obligation to furnish security for the due performance of his duties.

That the books and records of the company be destroyed twelve months after confirmation by the Master of the Supreme Court of the Final Liquidation and Distribution Account.

GARDEN HOLDINGS (PROPRIETARY) LIMITED**(Under Members' Voluntary Winding-up)**

Notice is hereby given in terms of Section 356 (2) (b) of the Companies Act, 1973, as amended, that at a general meeting of shareholders of the company held at 1st Floor, Quinbrow Chambers, 15 Western Road, Port Elizabeth, at 11.00 a.m. on 1st May, 1984 the following special resolutions were passed:

1. That the company be wound up voluntarily as a members' voluntary winding-up.
 2. That Mr Samuel Fanarof of 1st Floor, Quinbrow Chambers, 15 Western Road, Port Elizabeth, be and is hereby appointed liquidator of the company pursuant to Section 369 of the Companies Act, as amended.
 3. That he be exempted from furnishing security in terms of Section 375 of the said Act.
 4. That his remuneration be fixed at R750,00 for the purpose of such winding-up.
 5. That upon final dissolution of the company, the liquidator be and is hereby authorised and directed to destroy the books and records of the company in terms of Section 422 (1) (b) of the Companies Act, 1973, as amended.
- S. Fanarof, c/o Fanarof Brothers & Co., 1st Floor, Quinbrow Chambers, 15 Western Road, Port Elizabeth.

A. KELLNER (PROPRIETARY) LIMITED**VOLUNTARY LIQUIDATION****VOLUNTARY WINDING UP**

Notice is hereby given that the shareholders have resolved by Special Resolution passed on the 11th January 1984, that in terms of Section 349 of the Companies Act, No. 61 of 1973, as amended, the Company be wound up voluntarily.

It was further resolved that Sydney Saacks be appointed Liquidator and that he be not required to furnish security for the proper performance of his duties, subject to the approval of the Master of the Supreme Court.

To winding-up be a member's voluntary winding-up.

Saacks & Jaffe.

DAVIDSON FENN MARKETING (PROPRIETARY) LIMITED

Notice is hereby given in terms of Section 356 (2) (b) that at a meeting of the abovenamed company, the following resolution was passed:

That the company be wound up voluntarily under the provisions of Sections 349 and 351 of the Companies Act, 1973, as amended.

Coopers & Lybrand, P.O. Box 1913, Cape Town, 8000.

SIDMORLON TRUST (PROPRIETARY) LIMITED**NOTICE OF SPECIAL RESOLUTION TO WIND UP VOLUNTARILY****(IN TERMS OF SECTION 349 OF THE COMPANIES ACT, 1973, AS AMENDED)**

Notice is hereby given that on the 1st March 1984, the following Resolution passed on the 10th February 1984 was registered by the Registrar of Companies:

1. That the Company be wound up voluntarily by its members.
 2. That Gerhard Lodewyk Swanepoel, a representative of the firm of Arthur E. Abrahams & Gross, attorneys of 54 Shortmarket Street, Cape Town, be and is hereby appointed as Liquidator of the Company for the purpose of winding up its affairs and distributing its assets.
 3. That the Liquidator shall not be required to furnish security to the Master of the Supreme Court or to any other authority for the due fulfilment of his duties as such.
 4. That the remuneration of the Liquidator shall not be subject to the approval of the Master of the Supreme Court or any other authority.
- Arthur E. Abrahams & Gross, 54 Shortmarket Street, Cape Town.

MERFIELD INVESTMENTS (PROPRIETARY) LIMITED**KENNISGEWING VAN 'N SPESIALE BESLUIT OM MAATSKAPPY VRYWILLIG TE LIKWIDEER****[Kennisgewing in terme van Artikel 356 (2) (b) van die Maatskappywet, 1973]**

Kennis geskied hiermee dat 'n algemene vergadering van aandeelhouers van bogemelde maatskappy op 24 Mei 1984 die volgende Spesiale Besluite geneem het:

1. Die maatskappy vrywillig gelikwideer word deur lede.

2. Dat Gerhardus Johannes Vosloo aangestel word as Likwidateur vir doeleindes van die ontbinding van die maatskappy.
 3. Dat die Likwidateur vrygestel word van sekerheidstelling.
 4. Dat die boeke van die maatskappy vernietig word na die likwidasie van die maatskappy.
- G. J. Vosloo, Boland Bankgebou 300, Stellenbosch, 7600, 24/5/84.

MELFIN INVESTMENTS (PROPRIETARY) LIMITED

VOLUNTARY WINDING UP

Notice is hereby given that in terms of a special resolution passed by the Shareholders of the Company on 4th May 1984 and registered on 14th May 1984, it was resolved to wind up the Company by way of a members' voluntary winding up, that Kenneth David Penkin of Penkin Zeller and Karro, Chartered Accountants (SA), Monex House, 47 Strand Street, Cape Town, be appointed Liquidator of the Company and that the Liquidator be exempted from furnishing security.

LEANDO INVESTMENTS (PROPRIETARY) LIMITED

VOLUNTARY WINDING UP

Notice is hereby given that in terms of a special resolution passed by the Shareholders of the Company on 4th May 1984 and registered on 11th May 1984, it was resolved to wind up the Company by way of a members' voluntary winding up, that Kent George Karro of Penkin Zeller and Karro, Chartered Accountants (SA), Monex House, 47 Strand Street, Cape Town, be appointed Liquidator of the Company and that the Liquidator be exempted from furnishing security.

HAWTHORNE INVESTMENTS LIMITED

No. C330

CONVERSION OF COMPANY

Notice is hereby given that a General Meeting of the Members of Hawthorne Investments Limited will be held at the offices of Pim Goldby, 1st Floor, Permanent Building, Jones Street, Kimberley, on Monday 2nd July, 1984, at 10h00 for the purposes of considering and, if deemed fit, passing the following Special Resolutions:

1. That the Company be converted from a Public Company having a share capital, to a Private Company having a share capital.
2. That the word "(Proprietary)" be inserted before the word "Limited" in the name of the Company.
3. That the Company's Memorandum of Association be modified in order to conform with the provisions of the Companies Act, No. 61 of 1973.
4. That the Company's existing Articles of Association be cancelled, and that Table B of the Companies Act, 1973, be adopted with or without modifications.

Reasons and effect of the abovementioned resolutions.—The Company being simply a property-owning company, and having only 7 members, the Directors recommend that the Company be converted from a Public Company into a Private Company for administrative and other relevant reasons.

Duncan & Rothman, Attorneys for the Company, 3rd Floor, Permanent Building, Jones Street, P.O. Box 64, Kimberley, 25th May, 1984.

JERN (PROPRIETARY) LIMITED

VOLUNTARY WINDING UP

Notice is hereby given that in terms of a special resolution passed by the Shareholders of the Company on 4th May 1984 and registered on 15th May 1984, it was resolved to wind up the Company by way of a members' voluntary winding up, that Kenneth David Penkin of Penkin Zeller and Karro, Chartered Accountants (SA), Monex House, 47 Strand Street, Cape Town, be appointed Liquidator of the Company and that the Liquidator be exempted from furnishing security.

MATHILDE INVESTMENTS (PROPRIETARY) LIMITED

VOLUNTARY WINDING UP

Notice is hereby given that in terms of a special resolution passed by the Shareholders of the Company on 4th May 1984 and registered on 14th May 1984, it was resolved to wind up the Company by way of a members' voluntary winding up, that Kenneth David Penkin of Penkin Zeller and Karro, Chartered Accountants (SA), Monex House, 47 Strand Street, Cape Town, be appointed Liquidator of the Company and that the Liquidator be exempted from furnishing security.

CASCADE FALLS (PTY) LIMITED

VOLUNTARY WINDING-UP

Notice is hereby given that on the 29th February 1984 at a General Meeting of Shareholders of the above Company, the following Special Resolution was passed:

1. That the Company be wound up voluntarily in terms of sections 349 and 350 of the Companies Act, 1973, as amended, as a Members' Voluntary Winding-up.
2. That Dirk Johannes Jacobus Botha be and is hereby appointed Liquidator of the Company for the purpose of such winding-up, subject to the approval of the Master.
3. That the Liquidator be exempt from furnishing security to the Master.

Armstrong & Botha, 412-417 Geneca House, Parliament Street, Cape Town, 8001.

A. BRINK DIESEL CO. LIMITED

REG. No. 72/08897/07

KENNISGEWING VAN VOORGENOME OMSKEPPING VAN MAATSKAPPY

Kennisgewing geskied hiermee van 'n buitengewone vergadering van aandeelhouers van die maatskappy A. Brink Diesel Co. Limited en wat gehou sal word op 29 Junie 1984 om 11h00 te Haggie Randgebou, Bernudastraat, Paarden Eiland, Kaapstad. Die doel van die vergadering sal wees om—

- (i) die maatskappy te omskep in 'n privaat maatskappy met beperkte aanspreeklikheid;
- (ii) die statute aan te neem soos in Bylae 1 tabel B van die Maatskappywet van 1973, soos gewysig.

Brink Roos & Du Toit, Posbus 1647, Kaapstad, 8000.

CORITEX HOLDINGS (PROPRIETARY) LIMITED

No. 73/11507

VOLUNTARY WINDING-UP

Notice is hereby given that the following special resolution was passed pursuant to sections 349 and 350 (1) (a) of the Companies Act, 1973, as amended, at a general meeting of shareholders held for that purpose on 16th May 1984:

That the Company be and hereby is wound up voluntarily and that it be and hereby is placed under liquidation, subject to the following provisions and conditions:

- (a) That such winding-up be a members' voluntary winding-up in accordance with the provisions of section 349 of the Companies Act, 1973.
 - (b) That Harold Cohen be nominated in terms of section 350 (1) (a) of the Companies Act, 1973, as liquidator for the foregoing purposes and that subject to the subsequent confirmatory appointment by the Master of the Supreme Court under section 369 (1) of the said Act, such liquidator be vested with all the powers and authority conferred and allowed by the said Act.
 - (c) That the liquidator of the Company be not required to furnish security in terms of section 375 (1) of the Companies Act, 1973, for the due performance of his duties.
 - (d) That in terms of section 422 (1) of the Companies Act, 1973, the liquidator of the Company be authorised, when the Company has been wound up and dissolved, to dispose of the books and papers of the Company, by destroying them or procuring their destruction.
- May Fortes Tworetzky Cohen and Company, 401 Heerengracht Centre, Foreshore, Cape Town, 8001.

CARDESSAND PROPERTIES (PROPRIETARY) LIMITED**VOLUNTARY WINDING-UP**

Notice is hereby given in terms of Section 356 (2) (b) of the Companies Act, 1973, as amended, that at a general meeting of shareholders held on 15th May 1984 a special resolution was passed placing the company into voluntary liquidation as a members' voluntary winding-up.

Israel Trope of 801 Mobil House, Hans Strijdom Avenue, Cape Town, was appointed Liquidator and was exempted from furnishing security.

BINGO LIQUORS (PROPRIETARY) LIMITED

No. 81/04308/07

VOLUNTARY WINDING UP

Notice is hereby given that at a General Meeting of Shareholders held on 24th May 1984 it was resolved by special resolution that the Company be wound up in terms of Section 350 of the Companies Act.

It was further resolved that Peter Harold Cross be appointed Liquidator and that, subject to the sanction of the Master of the Supreme Court, he be not required to furnish security for the due performance of his duties.

CEE JAY CEE ENTÉRPRISES (PROPRIETARY) LIMITED

(IN VOLUNTARY LIQUIDATION)

Notice is hereby given that at a special general meeting held on 26th May 1984 it was resolved that the Company be wound up by means of a members' voluntary liquidation and that John Rex Neil Metelerkamp of Watson Building, 88 York Street, George, be appointed liquidator for this purpose. The liquidator is not required to provide the Master with security.

MORGERB (PROPRIETARY) LIMITED**MEMBERS VOLUNTARY WINDING UP**

In terms of Section 356 (2) (b) of the Companies Act, 1973, notice is hereby given that on 25th April 1984 the following special resolutions were passed at a general meeting of shareholders of the above company:

1. That the company be wound up voluntarily as a members Voluntary Liquidation in terms of Section 349 of the Companies Act, 1973.
 2. That Harold Mouldsdales Burnett be nominated liquidator.
 3. That the liquidator be authorised to dispose of the records of the Company and of his administration on receipt of the Master's Certificate provided for in Section 419 (1).
 4. That no security, as provided in Section 375 (1) of the Companies Act, 1973, need be lodged with the Master.
- H. M. Burnett, P.O. Box 411, Port Elizabeth, 6000.

NATAL**KILIBRA INVESTMENTS (PTY) LTD****VOLUNTARY WINDING-UP**

Notice pursuant to section 356 (2) (b) of the Companies Act, 1973, as amended

Notice is hereby given that the following Special Resolution was passed at a General Meeting of Shareholders of the Company held for that purpose at 1004 Sangro House, 413 Smith Street, Durban, on the 20th February 1984:

1. That the Company be wound up voluntarily as a Members Voluntary winding-up pursuant to sections 349 and 350 of the Companies Act, 1973, as amended, with effect from the 29th February 1984.
2. That Mr Philippe de Ravel of the firm De Ravel, Boule, Saad and Wyman be appointed Liquidator of the Company, pursuant to section 369 (1) of the Companies Act, as amended, for the purpose of such winding-up, that his remuneration be fixed at R250 and that he be exempted from furnishing security in terms of section 375 (1) of the Act.
3. That the Liquidator be authorised to destroy the books and documents of the Company or cause them to be destroyed on completion of the liquidation pursuant to section 422 (1) (b) of the Companies Act, 1973, as amended.

Mr F. J. G. Adant, Director.

VYPROP (PTY) LTD

No. N184/84

IN MEMBER'S VOLUNTARY LIQUIDATION

Notice is hereby given that in terms of Section 375 (5) (b) of the Companies Act, 1973, as amended, that Mr Philippe de Ravel of Messrs De Ravel, Boule, Saad and Wyman has been appointed Liquidator of the abovenamed Company by the Master of the Supreme Court of Pietermaritzburg on 14th May 1984.

Philippe de Ravel, Liquidator, for De Ravel, Boule, Saad and Wyman, 1004 Sangro House, 413 Smith Street, Durban; P.O. Box 2231, Durban, 4000, 21st May 1984.

A. F. BROKENSHA AND COMPANY (PROPRIETARY) LIMITED

Notice is hereby given that in terms of Section 356 (2) of the Companies Act, 1973, as amended, that the undernoted Special Resolutions to wind-up voluntarily which were passed at a Meeting of Members called for that purpose on 24th April 1984 were registered by the Registrar of Companies on 18th May 1984:

1. That the Company be and is hereby placed into voluntary liquidation as a members' winding-up.
2. That James Edgar Jarvis be and is hereby appointed Liquidator and that in terms of Section 375 (1) of the Companies Act, 1973, as amended, no security need be provided by the Liquidator.
3. That the remuneration of the Liquidator shall not exceed the tariff prescribed under the Insolvency Act.
4. That the books and records of the Company be destroyed six months after confirmation by the Master of the Supreme Court of the Final Liquidation and Distribution Account.

J. E. Jarvis, 30th Floor, Durban Bay House, 333 Smith Street, Durban, 4001.

TWIN SPRINGS CONTRACTORS (PTY) LIMITED

Pursuant to Section 356 (2) (b) of the Companies Act, 1973, notice is hereby given that at an Extraordinary General Meeting of Shareholders of the Company held at Durban on 5th March 1984 the following Special Resolutions were adopted:

1. That the company shall be voluntarily wound-up by its members in terms of Section 349 of the Companies Act, No. 61 of 1973.
2. That Neil Gerber of 1401 United Building, 291 Smith Street, Durban, be appointed Liquidator.
3. That the books and papers of the Company be placed in the custody of the Liquidator and that he be authorised to destroy them after the elapse of a period of one year from the date of dissolution of the company.
4. That the Liquidator's fees for the Liquidation of the Company are to be agreed between himself and the Shareholders at the conclusion of the Liquidation.

HI LI PROPERTIES (PROPRIETARY) LIMITED

Notice is hereby given that at a General Meeting of Shareholders held on 24th May 1984 the following Special Resolution was passed:

That the Company be wound up voluntarily as a Members' Voluntary Winding Up pursuant to the provisions of Section 349 (b) read with Section 350 of the Companies Act, No. 61 of 1973.

Brown & Levin, Agents to the Company, 6th Floor, United Building, 58 Field Street, Durban.

MOREGO INVESTMENTS (PROPRIETARY) LIMITED

Notice is hereby given that at a General Meeting of Shareholders held on 4th May 1984 the following Special Resolution was passed:

That the Company be wound up voluntarily as a Members' Voluntary Winding Up pursuant to the provisions of Section 349 (b) read with Section 350 of the Companies Act, No. 61 of 1973.

Dated at Durban this 22nd day of May 1984.

Brown & Levin, Agents to the Company, 6th Floor, United Building, 58 Field Street, Durban.

CHESTNUT INVESTMENT COMPANY (PROPRIETARY) LIMITED

Notice is hereby given that the following Resolutions were passed pursuant to Section 349 (b) of the Companies Act, 1973, as amended, at a General Meeting of Shareholders of the company held for that purpose at Suite 1922, 320 West Street, Durban, on 8th May, 1984:

1. That the company be liquidated by process of a members' voluntary winding-up in terms of Section 350 of the Companies Act, 1973, as amended, and that Mr Gert Tho, as Graham be and he is hereby nominated Liquidator of the company.
2. That the Liquidator's remuneration be agreed between the Directors and the Liquidator, provided it shall not exceed the tariff laid down in the Companies Act, 1973, as amended.
3. That in terms of Section 375 (1) of the Companies Act, 1973, as amended, it shall not be necessary for the Liquidator to furnish security for the due performance of his duties.
4. That upon the final dissolution of the company, the Liquidator be and he is hereby authorised and directed to destroy the books and records of the company or to procure their destruction in terms of Section 422 (1) of the Companies Act, 1973, as amended.

E. A. Paruk, Chairman.

MACLANDS INVESTMENTS (PTY) LIMITED

Pursuant to Section 356 (2) (b) of the Companies Act, 1973, notice is hereby given that at an Extraordinary General Meeting of Shareholders of the Company held at Durban on 3rd April 1984 the following Special Resolutions were adopted:

1. That the company shall be voluntarily wound-up by its members in terms of Section 349 of the Companies Act, No. 61 of 1973.
2. That Neil Gerber of 1401 United Building, 291 Smith Street, Durban, be appointed Liquidator.
3. That the books and papers of the Company be placed in the custody of the Liquidator and that he be authorised to destroy them after the elapse of a period of one year from the date of dissolution of the company.
4. That the Liquidator's fees for the Liquidation of the Company are to be agreed between himself and the Shareholders at the conclusion of the Liquidation.

MADANI SUPPLY STORE (PTY) LTD

Madani Supply Store (Pty) Ltd trading as Madani Meat Products/Cedara Wholesale Butchery and Madani Meat Supplies

(In provisional liquidation)

OFFER OF COMPROMISE

In terms of section 311 Companies Act, No. 61 of 1973, as amended, and on order of the supreme court Natal division dated 17th May 1984, the following meetings will be held on Tuesday, 19th June 1984 at 11.00 a.m. in the boardroom of Cecil Nathan Beattie & Co., Ground Floor, Main City Building, Longmarket Street, Pietermaritzburg:

- (a) Preferent Creditors.
- (b) Secured Creditors.
- (c) Concurrent Creditors.

The meetings are convened for the purpose of considering the offer of compromise, with or without modification, proposed by Nazir Ahmed in terms of Section 311 of the Companies Act, No. 61 of 1973, as amended, and if thought fit of accepting the scheme. A copy of the abovementioned court order as well as a copy of the statement in terms of Section 312 (1) (a) of the Companies Act may be inspected during normal business hours before the date of the meetings at the offices of Coopers & Lybrand, Abacus House, 108 Chapel Street, Pietermaritzburg. Creditors or any person entitled to attend the meetings will be provided with a copy of the aforementioned statement free of any charge upon application being made in writing to Coopers & Lybrand, Pietermaritzburg. In the event of the requisite majority of creditors required by Section 311 (2) of the Companies Act accepting the agreement with or without modification, application will be made to the aforementioned honourable court on 27th June 1984 for the court's sanction in terms of section 311 of the Companies Act.

Creditors who wish to vote at the meetings must lodge their proxies and claims, drawn up in accordance with the provisions of Section 44 of the Insolvency Act, No. 24 of 1936, at the offices of Coopers & Lybrand at least 24 hours before the meetings. Creditors holding security for their claims or a guarantee from third parties must notify the receiver at least 72 hours before the meeting to enable the receiver to value the security or guarantee.

BONITAS SHARE BLOCK (PTY) LTD

No. N153/84

IN MEMBER'S VOLUNTARY LIQUIDATION

Notice is hereby given that in terms of Section 375 (5) (b) of the Companies Act, 1973, as amended, that Mr Philippe de Ravel of Messrs De Ravel, Boulle, Saad and Wyman has been appointed Liquidator of the abovenamed Company by the Master of the Supreme Court of Pietermaritzburg on 16th May 1984.

Philippe de Ravel, Liquidator, for De Ravel, Boulle, Saad and Wyman, 1004 Sangro House, 413 Smith Street, Durban; P.O. Box 2231, Durban, 4000, 23rd May 1984.

CROOKES BROTHERS LIMITED

Directors: T. C. B. Crookes (Chairman), D. J. Crookes (Managing), A. C. Crookes, D. V. Crookes, J. F. C. Palmer, I. F. G. Gillatt, B. H. Hosking, C. Ratcliffe (Alternate)

INCOME AND DIVIDEND ANNOUNCEMENT

Income.—The audited results of the Group for the financial year ended 31st March 1984 together with those of the previous year are:

	1984	1983
	R	R
Group operating profit—South Africa	823 715	875 789
—Swaziland	505 323	353 821
Interest received	134 363	87 915
Income from investments	1 957 500	1 878 820
	<hr/>	<hr/>
Interest paid	3 420 901	3 196 345
	360 288	645 237
	<hr/>	<hr/>
Group profit before taxation	3 060 613	2 551 108
Taxation	422 295	270 195
	<hr/>	<hr/>
Group profit after taxation	2 638 318	2 280 913
	<hr/>	<hr/>
Number of shares in issue	3 000 000	3 000 000
Earnings per share—cents	87,9	76,0
Dividends per share—cents	63,0	60,0

In the interim report the Directors anticipated a dividend distribution of 65 cents per share for the year based on estimated earnings of 96,4 cents per share.

In the light of actual earnings being 87,9 cents per share a final dividend of 38 cents has been declared making a total distribution for the year of 63 cents.

For and on behalf of the Board.—T. C. B. Crookes, Chairman, D. V. Crookes, Director, 22nd May 1984.

Dividend notice.—A final dividend of 38 cents per share has been declared in respect of the year ended 31st March 1984 and will be paid on Friday 20th July 1984 to shareholders registered in the books of the company at close of business on Friday 6th July 1984. This dividend together with the interim dividend of 25 cents per share paid in January 1984 brings the total distribution for the year to 63 cents.

The transfer books and register of members of the company will be closed from 7th July to 15th July 1984, both dates inclusive.

Non-residents tax will be deducted where applicable.

By Order of the Board.—J. B. Abell, Secretary, Renishaw, 22nd May 1984.

INDUSTRIAL INVESTMENT COMPANY LIMITED

DECLARATION OF PREFERENCE DIVIDEND

Notice is hereby given that a Preference Dividend at the rate of three per cent (3 %) in respect of the six months ending 30th June 1984 on the 6 % Cumulative Preference Shares in the Company has been declared payable to holders of Preference Shares registered in the books of the Company at the close of business on the 15th June 1984.

The Preference Transfer Books and Register of Members will not be closed for the purpose of the dividend and cheques will be despatched on or about the 29th June 1984.

Non Resident Shareholders Tax at the effective rate of 14.87 % will be deducted by the Company from dividends in the case of shareholders whose addresses in the Share Register are outside the Republic of South Africa.

By Order of the Board.—H. G. Robertson, Secretary.

ORANJE-VRYSTAAT • ORANGE FREE STATE

THREE MEN (EIENDOMS) BEPERK

(In vrywillige likwidasië deur lede)

Kennis word hiermee gegee dat die volgende spesiale besluit geneem is in terme van Artikel 349 (b) en 350 (1) van die Maatskappywet, 1973, op 'n vergadering gehou vir die doel op 29 November 1983:

Dat die maatskappy hiermee vrywillig ontbind en gelikwedeer word, onderworpe aan die volgende voorwaardes:

- (a) Dat so 'n likwidasië 'n vrywillige likwidasië van lede ingevolge Artikel 349 (b) van die Maatskappywet, 1973, soos gewysig, sal wees.
- (b) Dat Abraham Christoffel Marais voorgestel word as likwidateur ingevolge Artikel 356 (2) (a) (i) van die Maatskappywet, 1973, ter voldoening aan bogenoemde vereistes en onderworpe aan die goedkeuring van die Meester van die Hooggeregshof ingevolge Artikel 369 (1) van die bovermelde Wet en dat vermelde likwidateur oor al die mag beskik soos toegelaat deur genoemde Wet.
- (c) Dat afgesien word van sekerheidstelling ingevolge Artikel 375 (1) van die Maatskappywet.
- (d) Dat likwidateursvergoeding vasgestel word op R450.
- (e) Dat die likwidateur gemagtig word om na ontbinding van die maatskappy die boeke en dokumente te vernietig of laat vernietig, kragtens Artikel 422 (1) van die Maatskappywet, 1973.

Viljoen Louw Bartel & Vennote, Posbus 818, Bloemfontein.

SUIDWES-AFRIKA • SOUTH WEST AFRICA

METJE & ZIEGLER LIMITED

(Incorporated in South West Africa)

NOTICE OF PREFERENCE DIVIDEND No. 72

Notice is hereby given that the dividend for the six months ending June 30th 1984, at the rate of 5½ % per annum has been declared payable on or about July 16th 1984, to all preference shareholders registered in the books of the company at the close of business on June 22nd 1984.

In terms of the SWA and RSA income tax legislation, non-resident shareholders' tax is applicable as outlined below:

Shareholders resident in South West Africa: 1.01 %.

Shareholders resident in the Republic of South Africa: 11.65 %.

Shareholders resident outside South West Africa and the Republic of South Africa: 12.66 %.

By Order of the Board.—K. A. H. A. S. von der Pforte, Secretary. Transfer Secretaries: Arthur Young & Company, P.O. Box 1857, Windhoek, 9000.

LIKWIDATEURS EN ANDER AANGESTELDES SE KENNISGEWINGS LIQUIDATORS' AND OTHER APPOINTEES' NOTICES

Kennisgewings deur likwidateurs en ander aangesteltes soos eksekuteurs, geregtelike bestuurders, trustees, kurators of voogde, van aanstellings, vergaderings, rekeninge, eise, verlof, vrystellings, ens.

Notices by liquidators and other appointees such as executors, judicial managers, trustees, curators or tutors, of appointments, meetings, accounts, claims, leave of absence, releases, etc.

TRANSVAAL

V.H.E.J. PROPERTIES (PROPRIETARY) LIMITED

UNDER MEMBERS' VOLUNTARY LIQUIDATION

REGISTRATION No. 69/01712/07

Notice is hereby given in terms of Section 375 (5) (b) of the Companies Act, 1973, as amended, that Abraham Levenstein of P.O. Box 46295, Orange Grove, 2119, has been appointed Liquidator of the above company by the Master of the Supreme Court (Transvaal Provincial Division) under Certificate of Appointment No. T 675/84.

PATERSON ROAD PROPERTIES (PTY) LTD

In terms of Section 356 (2) (b) of the Companies Act, 1973:

At a General Meeting of the Company held on 12 April 1984, the following resolutions were passed:

1. That the major asset of the Company having been sold, the company be Liquidated as a members' Voluntary Winding Up, in terms of Section 350 of the Companies Act 1973 as amended.
2. That Arnold Gochln be appointed liquidator and that in terms of Section 375 of the Companies Act 1973, as amended, no security be required for the proper performance of his duties as liquidator.
3. That the Liquidators fee of R750, plus any additional charges in respect of the matter of H. Wren be approved.
4. That S. Gochln be authorised to sign the documents on behalf of the Directors.

HERMOINE INVESTMENTS (PROPRIETARY) LIMITED
VOLUNTARY LIQUIDATION
NUMBER T163/82/OND 3 B

Notice is hereby given in terms of Section 409 (2) (of the Companies Act 1973) that the Final Liquidation and Distribution Account of the above company was duly confirmed on the 8 May 1984, by the Master of the Supreme Court.

P. J. Jaffe, Liquidator, P.O. Box 6697, Johannesburg, 2000.

PHILBRO HARRIANNE COURT (PROPRIETARY) LIMITED
MEMBERS' VOLUNTARY LIQUIDATION
T2134/83/ASR 2

Notice is hereby given in terms of Section 375 (5) (b) of the Companies Act 1973, that Eli Milner, P.O. Box 8170, Johannesburg, was appointed Liquidator of the above Company by the Master of the Supreme Court (Pretoria) on the 8th May 1984.

Eli Milner, P.O. Box 8170, Johannesburg.

CORONA BLOEMISTE (EIENDOMS) BEPERK
In Vrywillige Likwidasie
T530/84

Kennis geskied hiermee ingevolge artikel 375 (b) van die Maatskappywet, 1973, dat ondergenoemde as likwidateur van die maatskappy aangestel is deur die Meester van die Hooggeregshof.

P. Stockwell, Posbus 1120, Pretoria, 0001.

KAAP • CAPE

SIGNAL HILL PUBLICATIONS (PTY) LTD
in Voluntary Liquidation

Notice is hereby given in terms of Section 375 (5) (b) of the Companies Act, 1973, as amended, that **Robert John Torr de Beer**, of 68 Main Road, Claremont, Cape Town was appointed Liquidator of the above-named company by the Master of the Supreme Court, Cape Town on 17 May 1984.

R. J. T. de Beer, P.O. Box 461, Claremont, 7735.

NATAL

TEMPLE CHAMBERS (PROPRIETARY) LIMITED
(in Voluntary Liquidation)
No. N.142/84

In terms of Section 375 (5) (b) notice is hereby given that **Cecil Lambert Rhodes**, P.O. Box 487, Durban, 4000, has been appointed liquidator of the company.

Cecil Lambert Rhodes.

MARKLIN HOLDINGS (PTY) LTD

Notice is hereby given that **John Miller van Wijk** of the Firm, Holliday, Van Wijk & Co., has been appointed Liquidator by the Master of the Supreme Court of the abovementioned Company by the issuance of Certificate of Appointment No. N186/84 dated 8th May, 1984.

Holliday, Van Wijk & Co., P.O. Box 2815, Durban, 4000.

VIVIAN PROPERTIES (PROPRIETARY) LIMITED
MASTER'S REFERENCE NUMBER N. 147/84

Notice is hereby given in terms of Section 375 (5) of the Companies Act, 1973 (as amended), that I was appointed Liquidator of the Company in terms of a Certificate of Appointment issued by the Master of the Supreme Court, Pietermaritzburg, on the 10th April, 1984.

Memory Alice Bullough of Probitas Trust & Finance Co. (Pty) Limited.

E. B. KING HILLSIDE INVESTMENTS (PTY) LTD
VOLUNTARY WINDING UP

Notice is hereby given that the following special resolution was passed at a general meeting of shareholders on 27/4/84:

1. That the Company be wound up voluntarily as a members' voluntary winding up.
2. That William Richard Oliver Hutchinson be appointed liquidator of the Company pursuant to section 350 (a) of the Companies Act, 1973, as amended.
3. That the liquidator with the consent of the Master of the Supreme Court be exempt from furnishing security in terms of section 350 (c) of the said act.
4. That the liquidator in terms of section 375 (1) be and is hereby exempt from furnishing security for the proper performance of his duty as a liquidator.
5. That in terms of Section 422 (1) of the Companies Act, 1973, as amended, the liquidator of the company be authorised, when the Company has been wound up and dissolved, to dispose of the books and records of the Company by destroying them or procuring their destruction.
6. That the remuneration of the liquidator be fixed at R500-00 (Five hundred rands only).

W. R. O. Hutchinson, P.O. Box 5817, Durban, 4000.

TOSELLO (PTY) LTD
VOLUNTARY WINDING UP

Notice is hereby given that the following special resolution was passed at a general meeting of shareholders on 21/5/84:

1. That the Company be wound up voluntarily as a members' voluntary winding up.
 2. That William Richard Oliver Hutchinson be appointed liquidator of the Company pursuant to section 350 (a) of the Companies Act, 1973, as amended.
 3. That the liquidator with the consent of the Master of the Supreme Court be exempt from furnishing security in terms of section 350 (c) of the said act.
 4. That the liquidator in terms of section 375 (1) be and is hereby exempt from furnishing security for the proper performance of his duty as a liquidator.
 5. That in terms of Section 422 (1) of the Companies Act, 1973, as amended, the liquidator of the company be authorised, when the Company has been wound up and dissolved, to dispose of the books and records of the Company by destroying them or procuring their destruction.
 6. That the remuneration of the liquidator be fixed at R500-00 (Five hundred rands only).
- W. R. O. Hutchinson, P.O. Box 5817, Durban, 4000.

ORDERS VAN DIE HOF • ORDERS OF THE COURT

Transvaalse Provinsiale Afdeling, Pretoria
Transvaal Provincial Division, Pretoria

Saak 7034/84

IN DIE HOOGGEREGSHOF VAN SUID-AFRIKA
(Transvaalse Provinsiale Afdeling)

Pretoria die 22ste dag van Mei 1984 voor Sy Edele Regter Eloff

In die saak tussen **Martin Johannes van Heerden**, Applikant, en **Draaihoek Beleggings (Edms.) Beperk**, geregistreerde adres te Burger en Buurman Hansagebou, Arrasstraat, Witbank, Tvl., Respondent

Na aanhoor van die advokaat namens die applikant en na deurlees van die Kennisgewing van Mosie en ander stukke:

Word gelas:

1. Dat die bogemelde respondent maatskappy hierby in voorlopige likwidasië geplaas word;
 2. Dat 'n bevel *nisi* hierby uitgereik word wat alle belanghebbende persone oproep om redes, indien enige, voor hierdie hof aan te voer om 10h00 op die 12de Junie 1984 waarom die respondent maatskappy nie onder finale likwidasië geplaas sal word nie;
 3. Dat betekening van hierdie bevel *nisi* geskied aan die respondent maatskappy by sy geregistreerde kantoor, aan alle bekende skuldeisers van die respondent maatskappy per geregistreerde pos en onverwyld gepubliseer word eenmaal in elk in die *Staatskoerant* en die *Beeld* nuusblad.
- Deur die Hof.—Hofgriffier.

Case 9591/84

IN THE SUPREME COURT OF SOUTH AFRICA
(Transvaal Provincial Division)

Pretoria, the 22nd day of May, 1984 before the Honourable Mr Justice Eloff

In the matter between **African Shipping**, Applicant and **Austrian Alcohol Sales**, registered offices at Leopont 301, 451 Church Street, Pretoria East, Respondent

Having heard Counsel for the applicant and having read the Notice of Motion and other documents filed;

It is Ordered:

1. That the abovementioned respondent company be and is hereby placed in provisional winding-up order;
2. That a rule *nisi* do issue calling upon all persons concerned to appear and show cause if any, to this Court at 10 a.m. on the 26th June 1984 why the respondent company should not be placed under final winding-up order;
3. That service of this rule *nisi* be effected upon the respondent company at its registered office and by publication forthwith once in each of the *Government Gazette*, and *The Star* newspapers.

By the Court.—Court Registrar.

Case 20241/83

IN THE SUPREME COURT OF SOUTH AFRICA
(Transvaal Provincial Division)

Pretoria, the 22nd day of May, 1984 before the Honourable Mr Justice Eloff

In the matter between **Isowall Manufacturing (Pty) Ltd**, Applicant and **Isodor (Pty) Ltd**, registered office at c/o Willem du Toit & Partners, Sunnypark Centre, Esselen Street, Sunnyside, Pretoria, Respondent

Having heard Counsel for the applicant and having read the Notice of Motion and other documents filed:

It is Ordered:

1. That the abovementioned respondent company be and is hereby placed in provisional winding-up order;
2. That a rule *nisi* do issue calling upon all persons concerned to appear and show cause if any, to this Court at 10h00 on the 26th June 1984 why the respondent company should not be placed under final winding-up order;
3. That service of this rule *nisi* be effected upon the respondent company at its registered office, upon all known creditors of the respondent company by registered post and by publication forthwith once in each of the *Government Gazette*, and *Pretoria News* newspapers.

By the Court.—Registrar.

ORDERS VAN DIE HOF (vervolg) • ORDERS OF THE COURT (continued)

Saak 3782/84

IN DIE HOOGGEREGSHOF VAN SUID-AFRIKA
(Transvaalse Provinsiale Afdeling)

Pretoria, die 23ste dag van Februarie 1984 voor Sy Edele Regter Weyers (Waarnemend)

In die saak tussen **W. C. Wiegand**, Applikant, en **Living Image**, Steenstraat 31, Rustenburg, 1ste Respondent, **J. J. Cawood**, Mahoganylaan 5, Proteapark, Rustenburg, 2de Respondent, **A. Cawood**, Mahoganylaan 5, Proteapark, Rustenburg, 3de Respondent

Na aanhoor van die advokaat namens die applikant en na deurlees van die stukke geliasseer:

*Word gelas:*Dat die private- en vennootskap-boedels van **Living Image**, Joseph Josia Cawood en Annelie Cawood hierby in voorlopige sekwestrasie geplaas word in die hande van die Meester van die Hooggeregshof, en dat 'n bevel *nisi* hierby uitgereik word wat die respondente oproep om redes, indien enige voor hierdie hof aan te voer om 10 uur vm. op die 13de Maart 1984 waarom 'n finale bevel van sekwestrasie nie teen hulle boedels gemaak sal word nie.

Deur die Hof.—Hofgriffier.

Saak 3782/84

IN DIE HOOGGEREGSHOF VAN SUID-AFRIKA
(Transvaalse Provinsiale Afdeling)

Pretoria die 29ste dag van Mei 1984 voor Sy Edele Regter Human (Waarnemende)

In die saak tussen van **W. C. Wiegand**, Applikant, en **Living Image**, 1ste Respondent **J. J. Cawood**, 2de Respondent, **A. Cawood**, 3de RespondentNa aanhoor van die advokaat namens die applikant en na deurlees van die bevel *nisi* uitgereik deur hierdie Hof op 23 Februarie 1984:*Word gelas:*

1. Dat die keerdatum van die voormelde Bevel *Nisi* hierby verleng word tot 19 Junie 1984.
2. Dat die Bevel *Nisi* beteken word deur:
 - 2.1 aanhegting daarvan op of in die nabyheid van die buitedeur van die gebou waarin hierdie hof sit; en
 - 2.2 publikasie daarvan in die *Staatskoerant*.
3. Dat die koste van die aansoek om alternatiewe betekening koste in die administrasie van die insolvente boedels van die Respondente sal wees.

Deur die Hof.—Hofgriffier.

Witwatersrandse Plaaslike Afdeling, Johannesburg
Witwatersrand Local Division, Johannesburg

Case 4882/84

IN THE SUPREME COURT OF SOUTH AFRICA
(Witwatersrand Local Division)

Johannesburg, the 13th day of March 1984 before the Honourable Mr Justice Philips (Acting)

In the matter between **Dworbro Investments (Pty) Ltd**, t/a The Sandpit, Applicant; and **Godfrey van Onselen**, who resides at 140 Market Street, Boksburg, Transvaal, Respondent

Having heard Counsel for the Applicant and having read the Application:

*It is Ordered:*That the estate of the abovenamed Respondent be and is hereby placed under provisional Sequestration in the hands of the Master and that a Rule *Nisi* do issue calling upon the Respondent to appear and, to show cause, if any, to this Court on the 10th day of April 1984 at 10.00 a.m., why a final Order of Sequestration should not be granted against his estate.

By the Court.—M. S. van der Watt, Registrar.

Case 4882/84

IN THE SUPREME COURT OF SOUTH AFRICA
(Witwatersrand Local Division)

Johannesburg, the 10th day of April 1984 before the Honourable Mr Justice Esselen

In the matter between **Dworbro Investments (Pty) Ltd**, t/a The Sandpit, Applicant, and **Godfrey van Onselen**, RespondentUpon the motion of Counsel for the Applicant and upon reading the Rule *Nisi* and provisional Order of Sequestration issued out of this Court on the 13th day of March 1984.*It is Ordered:*That the return day of the aforesaid Rule *Nisi* be and is hereby extended to the 1st day of May 1984.

By the Court.—G. T. M. Prinsloo, Registrar.

Case 4882/84

IN THE SUPREME COURT OF SOUTH AFRICA
(Witwatersrand Local Division)

Johannesburg, the 1st day of May 1984 before the Honourable Mr Justice Van Niekerk

In the matter between **Dworbro Investments (Pty) Ltd**, t/a The Sandpit, Applicant, and **Godfrey van Onselen**, RespondentUpon the motion of Counsel for the Applicant and upon reading the Rule *Nisi* and provisional Order of Sequestration issued out of this Court on the 13th day of March 1984:*It is Ordered:*That the return day of the aforesaid Rule *Nisi* be and is hereby extended to the 22nd day of May 1984.

By the Court.—M. S. van der Watt, Registrar.

ORDERS VAN DIE HOF (vervolg) • ORDERS OF THE COURT (continued)

Case 4882/84

**IN THE SUPREME COURT OF SOUTH AFRICA
(Witwatersrand Local Division)**

Johannesburg, the 22nd day of May 1984 before the Honourable Mr Justice Zulman (Acting)

In the matter between Dworbro Investments (Pty) Ltd, t/a The Sandpit, Applicant, and Godfrey van Onselen, Respondent

Upon the motion of Counsel for the Applicant and upon reading the Rule *Nisi* and provisional Order of Sequestration issued out of this Court on the 13th day of March 1984:*It is Ordered:*That the return day of the aforesaid Rule *Nisi* be and is hereby extended to the 12th day of June 1984.That service of the rule and the postea to be effected by leaving a copy thereof at the Defendants previous place of residence and by publication once in the *Government Gazette* and daily newspaper.

By the Court.—G. T. M. Prinsloo, Registrar.

Case 11347/84

**IN THE SUPREME COURT OF SOUTH AFRICA
(Witwatersrand Local Division)**

Johannesburg, the 22nd May 1984 before the Honourable Mr Justice Vermooten (Acting)

In the matter between Minros Engineering (Pty) Ltd, having its registered office at 3rd Floor, S.A. Perm Building, 23 Goldman Street, Florida, Applicant

Having heard Counsel for the Applicant and having read the Application:

It is Ordered:

1. That the abovementioned Applicant Company be and is hereby placed under provisional winding-up Order in the hands of the Master.

2. That a Rule *Nisi* do issue calling upon all persons concerned to appear and to show cause, if any, to this Court on the 26th day of June 1984 at 10.00 a.m., why the said Applicant Company should not be placed under final winding-up Order.3. That a copy of this Rule *Nisi* be served on the Applicant Company at its registered office and be published forthwith once in the *Government Gazette* and in a Johannesburg daily newspaper.4. That a copy of this Rule *Nisi* be served on all known creditors by registered post.*N.B.* Any creditor who requires further information regarding this matter should communicate with the attorney/s reflected at the foot of this Order and/or with the Master of the Supreme Court, Private Bag X60, Pretoria, 0001 (Tel. 012-286521).

By the Court.—M. S. van der Watt, Registrar.

Richard Treisman.

Case 11689/84

**IN THE SUPREME COURT OF SOUTH AFRICA
(Witwatersrand Local Division)**

Johannesburg, the 22nd day of May 1984 before the Honourable Mr Justice Vermooten (Acting)

In the matter of Salls Waterproofing and Contracting (Pty) Ltd, having its registered office at c/o Milner and Partners, 721 Rand Central Building, 165 Jeppe Street, Johannesburg, Transvaal, Applicant

Having heard Counsel for the Applicant and having read the Application:

It is Ordered:

1. That the abovementioned Applicant Company be and is hereby placed under provisional winding-up Order in the hands of the Master.

2. That a Rule *Nisi* do issue calling upon all persons concerned to appear and to show cause, if any, to this Court on the 19th day of June 1984 at 10.00 a.m., why the said Applicant Company should not be placed under final winding-up Order.3. That a copy of this Rule *Nisi* be served on the Applicant Company at its registered office and be published forthwith once in the *Government Gazette* and in a Johannesburg daily newspaper.4. That a copy of this Rule *Nisi* be served on all known creditors by registered post.*N.B.* Any creditor who requires further information regarding this matter should communicate with the attorney/s reflected at the foot of this Order and/or with the Master of the Supreme Court, Private Bag X60, Pretoria, 0001 (Tel. 012-286521).

By the Court.—M. S. van der Watt, Registrar.

T. G. Fine.

Case 11700/84

**IN THE SUPREME COURT OF SOUTH AFRICA
(Witwatersrand Local Division)**

Johannesburg, the 22nd day of May 1984 before the Honourable Mr Justice Vermooten (Acting)

In the matter between Christopher Peter van Zyl, Applicant, and A to Z Shoe Company (Pty) Ltd, carrying on business as a retail shoe merchant, having its registered office at 19th Floor, Shell House, 51 Plein Street, Johannesburg, Respondent

Having heard Counsel for the Applicant and having read the Application:

It is Ordered:

1. That the abovementioned Respondent Company be and is hereby placed under provisional winding-up Order in the hands of the Master.

2. That a Rule *Nisi* do issue calling upon all persons concerned to appear and to show cause, if any, to this Court on the 3rd day of July 1984 at 10.00 a.m., why the said Respondent Company should not be placed under final winding-up Order.

ORDERS VAN DIE HOF (vervolg) • ORDERS OF THE COURT (continued)

3. That a copy of this Rule *Nisi* be served on the Respondent Company at its registered office and be published forthwith once in the *Government Gazette* and in a Johannesburg daily newspaper.

4. That a copy of this Rule *Nisi* be served on all known creditors by registered post.

N.B. Any creditor who requires further information regarding this matter should communicate with the attorney/s reflected at the foot of this Order and/or with the Master of the Supreme Court, Private Bag X60, Pretoria, 0001 (Tel. 012-286521).

By the Court.—M. S. van der Watt, Registrar.

M. H. Citrota.

Case 11701/84

IN THE SUPREME COURT OF SOUTH AFRICA
(Witwatersrand Local Division)

Johannesburg, the 22nd day of May 1984 before the Honourable Mr Justice Vermooten (Acting)

In the matter between **Christopher Peter van Zyl**, Applicant, and **Kevcraig Shoes (Pty) Ltd**, carrying on business as a retail shoe merchant and having its registered office at 19th Floor, Shell House, 51 Plein Street, Johannesburg, Respondent

Having heard Counsel for the Applicant and having read the Application:

It is Ordered:

1. That the abovementioned Respondent Company be and is hereby placed under provisional winding-up Order in the hands of the Master.
2. That a Rule *Nisi* do issue calling upon all persons concerned to appear and to show cause, if any, to this Court on the 3rd day of July 1984 at 10.00 a.m., why the said Respondent Company should not be placed under final winding-up Order.

3. That a copy of this Rule *Nisi* be served on the Respondent Company at its registered office and be published forthwith once in the *Government Gazette* and in a Johannesburg daily newspaper.

4. That a copy of this Rule *Nisi* be served on all known creditors by registered post.

N.B. Any creditor who requires further information regarding this matter should communicate with the attorney/s reflected at the foot of this Order and/or with the Master of the Supreme Court, Private Bag X60, Pretoria, 0001 (Tel. 012-286521).

By the Court.—M. S. van der Watt, Registrar.

M. H. Citrota.

Case 6454/84

IN THE SUPREME COURT OF SOUTH AFRICA
(Witwatersrand Local Division)

Johannesburg, the 7th day of May 1984 before the Honourable Mr Justice Van Niekerk

In the matter between **The Professional Assignments Group Ltd**, Applicant, and **Clemcrest Engineering (Pty) Ltd**, having its registered office at 301 Argent House, 21 Loveday Street South, Johannesburg, Respondent

Having heard Counsel for the Applicant and having read the Application:

It is Ordered:

1. That the abovementioned Respondent Company be and is hereby placed under provisional winding-up Order in the hands of the Master.
2. That a Rule *Nisi* do issue calling upon all persons concerned to appear and to show cause, if any, to this Court on the 26th day of June 1984 at 10.00 a.m., why the said Respondent Company should not be placed under final winding-up Order.

3. That a copy of this Rule *Nisi* be served on the Respondent Company at its registered office and be published forthwith once in the *Government Gazette* and in the *Vaderland* and *The Star*.

4. That a copy of this Rule *Nisi* be served on all known creditors by registered post.

5. That the costs of this Application be paid as costs in the winding-up Order, such costs to include costs of two counsel.

6. That in regard to the Application to strike out the following Order is made:

(a) Last sentence in par. 10 f (iv) (pg. 117) commencing with the words "in addition" to the end of that sub-par., up to and including the last par. on pg. 118, is struck out.

By the Court.—G. T. M. Prinsloo, Registrar.

Case 9720/84

IN THE SUPREME COURT OF SOUTH AFRICA
(Witwatersrand Local Division)

Johannesburg, the 15th day of May 1984 before the Honourable Mr Justice Gordon

In the matter of **Keith William Leggett**, Applicant, and **Jakarta Trading (Pty) Ltd**, having its registered office at c/o Goldberg, Jaffe, Joselowsky & Partners, 6th Floor, Saambou National Building, 130 Commissioner Street, Johannesburg, Respondent

Having heard Counsel for the Applicant and having read the Application:

It is Ordered:

1. That the abovementioned Respondent Company be and is hereby placed under provisional winding-up Order in the hands of the Master.
2. That a Rule *Nisi* do issue calling upon all persons concerned to appear and to show cause, if any, to this Court on the 26th day of June 1984 at 10.00 a.m., why the said Respondent Company should not be placed under final winding-up Order.

3. That a copy of this Rule *Nisi* be served on the Respondent Company at its registered office and be published forthwith once in the *Government Gazette* and in a Johannesburg daily newspaper.

By the Court.—G. T. M. Prinsloo, Registrar.

ORDERS VAN DIE HOF (vervolg) • ORDERS OF THE COURT (continued)

Case 9719/84

IN THE SUPREME COURT OF SOUTH AFRICA
(Witwatersrand Local Division)

Johannesburg, the 15th day of May 1984 before the Honourable Mr Justice Gordon

In the matter between **Keith William Leggett**, Applicant, and **Crown Cold Storage (Pty) Ltd**, having its registered office at care of Goldberg, Jaffe, Joselowsky & Partners, Sixth Floor, Saambou National Building, 130 Commissioner Street, Johannesburg, Respondent

Having heard Counsel for the Applicant and having read the Application:

It is Ordered:

1. That the abovementioned Respondent Company be and is hereby placed under provisional winding-up Order in the hands of the Master.
2. That a Rule *Nisi* do issue calling upon all persons concerned to appear and to show cause, if any, to this Court on the 26th day of June 1984 at 10.00 a.m., why the said Respondent Company should not be placed under final winding-up Order.
3. That a copy of this Rule *Nisi* be served on the Respondent Company at its registered office and be published forthwith once in the *Government Gazette* and in a Johannesburg daily newspaper.

By the Court.—G. T. M. Prinsloo, Registrar.

Case 7392/84

IN THE SUPREME COURT OF SOUTH AFRICA
(Witwatersrand Local Division)

Johannesburg, the 17th day of May 1984 before the Honourable Mr Justice Gordon

In the matter between **Ken's Electrical**, Applicant, and **Staal Skure en Fabriek (Edms.) Bpk.**, having its principal place of business at Kirschner Street, Boksburg North, and having its registered office at 88 Kirschner Street, Boksburg North, Respondent

Having heard Counsel for the Applicant and having read the Application:

It is Ordered:

1. That the abovementioned Respondent Company be and is hereby placed under provisional winding-up Order in the hands of the Master.
2. That a Rule *Nisi* do issue calling upon all persons concerned to appear and to show cause, if any, to this Court on the 19th day of June 1984 at 10.00 a.m., why the said Respondent Company should not be placed under final winding-up Order.
3. That a copy of this Rule *Nisi* be served on the Respondent Company at its registered office and be published forthwith once in the *Government Gazette* and in a Johannesburg daily newspaper.

By the Court.—G. T. M. Prinsloo, Registrar.

Case 6434/84

IN THE SUPREME COURT OF SOUTH AFRICA
(Witwatersrand Local Division)

Johannesburg, the 1st day May 1984 before the Honourable Mr Justice Schabert

In the matter between **Agrogard Marketing (Pty) Ltd**, Applicant, and **Green-Gro Marketing (Pty) Ltd**, having its registered office at Sixth Floor, Tigrade House, 112 Kerk Street, Johannesburg, Respondent

Having heard Counsel for the Applicant and having read the Application:

It is Ordered:

1. That the abovementioned Respondent Company be and is hereby placed under provisional winding-up Order in the hands of the Master.
2. That a Rule *Nisi* do issue calling upon all persons concerned to appear and to show cause, if any, to this Court on the 12th day of June 1984, at 10.00 a.m., why the said Respondent Company should not be placed under final winding-up Order.
3. That a copy of this Rule *Nisi* be served on the Respondent Company at its registered office and be published forthwith once in the *Government Gazette* and in a Johannesburg daily newspaper.

By the Court.—G. T. M. Prinsloo, Registrar.

Case 9600/84

IN THE SUPREME COURT OF SOUTH AFRICA
(Witwatersrand Local Division)

Johannesburg, the 22nd May 1984 before the Honourable Mr Justice Vermooten (Acting)

In the matter between **Edward Fredrick Goerge Clayson**, Applicant, and **Panem Properties (Pty) Ltd**, u/a Aljadine Engineering, having its registered office at c/o Ernst & Whinney, Third Floor, Humark Building, Human Street, Krugersdorp, Respondent

Having heard Counsel for the Applicant and having read the Application:

It is Ordered:

1. That the abovementioned Respondent Company be and is hereby placed under provisional winding-up Order in the hands of the Master.
2. That a Rule *Nisi* do issue calling upon all persons concerned to appear and to show cause, if any, to this Court on the 26th day of June 1984 at 10.00 a.m., why the said Respondent Company should not be placed under final winding-up Order.
3. That a copy of this Rule *Nisi* be served on the Respondent Company at its registered office and be published forthwith once in the *Government Gazette* and in a Johannesburg daily newspaper.

By the Court.—M. S. van der Watt, Registrar.

ORDERS VAN DIE HOF (vervolg) • ORDERS OF THE COURT (continued)

Case 9969/84

**IN THE SUPREME COURT OF SOUTH AFRICA
(Witwatersrand Local Division)**

Johannesburg, the 22nd May 1984 before the Honourable Mr Justice Vermooten (Acting)

In the matter between **Riol (Pty) Ltd**, t/a Thrutainers International, Applicant, and **Inship (Pty) Ltd**, having its principal place of business at 311 Commissioner Street, Johannesburg, Respondent

Having heard Counsel for the Applicant and having read the Application:

It is Ordered:

1. That the abovementioned Respondent Company be and is hereby placed under provisional winding-up Order in the hands of the Master.
2. That a Rule *Nisi* do issue calling upon all persons concerned to appear and to show cause, if any, to this Court on the 3rd day of July 1984, at 10.00 a.m., why the said Respondent Company should not be placed under final winding-up Order.
3. That a copy of this Rule *Nisi* be served on the Respondent Company at its registered office and be published forthwith once in the *Government Gazette* and in a Johannesburg daily newspaper.

By the Court.—M. S. van der Watt, Registrar.

Case 11156/84

**IN THE SUPREME COURT OF SOUTH AFRICA
(Witwatersrand Local Division)**

Johannesburg, the 15th day of May 1984 before the Honourable Mr Justice Gordon

In the matter of **Le Figaro (Pty) Ltd**, having its registered office at Suite 201 Factor House, 12 Kruis Street, Johannesburg and carrying on business as a Hairdressing Salon under the name **Le Figaro** at 136 (a) Market Street, Johannesburg, Applicant

Having heard Counsel for the Applicant and having read the Application:

It is Ordered:

1. That the abovementioned Applicant Company be and is hereby placed under provisional winding-up Order in the hands of the Master.
2. That a Rule *Nisi* do issue calling upon all persons concerned to appear and to show cause, if any, to this Court on the 26th day of June 1984 at 10.00 a.m., why the said Applicant Company should not be placed under final winding-up Order.
3. That a copy of this Rule *Nisi* be served on the Applicant Company at its registered office and be published forthwith once in the *Government Gazette* and in a Johannesburg daily newspaper.

By the Court.—G. T. M. Prinsloo, Registrar.

Case 11158/84

**IN THE SUPREME COURT OF SOUTH AFRICA
(Witwatersrand Local Division)**

Johannesburg, the 15th day of May 1984 before the Honourable Mr Justice Gordon

In the matter between **A & S Fire Engineering (Pty) Limited**, having its registered office at the farm Waterval, Old Pretoria Road, Sandton, Applicant

Having heard Counsel for the Applicant and having read the Application:

It is Ordered:

1. That the abovementioned Applicant Company be and is hereby placed under provisional winding-up Order in the hands of the Master.
2. That a Rule *Nisi* do issue calling upon all persons concerned to appear and to show cause, if any, to this Court on the 19th day of June, 1984 at 10.00 a.m., why the said Applicant Company should not be placed under final winding-up Order.
3. That a copy of this Rule *Nisi* be served on the Applicant Company at its registered office and be published forthwith once in the *Government Gazette* and in a Johannesburg daily newspaper.

By the Court.—G. T. M. Prinsloo, Registrar.

**Plaaslike Afdeling Durban en Kus, Durban
Durban and Coast Local Division, Durban**

Case 3479

**IN THE SUPREME COURT OF SOUTH AFRICA
(Durban and Coast Local Division)**

Durban, the 14th day of May 1984 before the Honourable Mr Justice Shearer

In the matter between **Christine Anne Foley**, Applicant and **C. Foley Investments (Proprietary) Limited**, Respondent

Upon the Motion of counsel for the Applicant and upon reading the Notice of Motion and the other documents filed of record:

It is Ordered:

- (a) That the Respondent and all other interested parties are called upon to show cause before this Honourable Court on the 25th of June 1984, at 9.30 a.m. why the Respondent Company should not be placed in Liquidation in the hands of the Master;
- (b) That pending the return date of the aforesaid Rule the Respondent is placed under Provisional Liquidation;
- (c) That a copy of this Order shall be published in the daily newspaper published and circulating in Natal and once in the *Government Gazette* on or before the 11th of June 1984.

By Order of the Court.—E. M. Kriel, Registrar.

ORDERS VAN DIE HOF (vervolg) • ORDERS OF THE COURT (continued)

Case 821/84

IN THE SUPREME COURT OF SOUTH AFRICA
(Durban and Coast Local Division)

Durban, the 11th of May 1984; before the Honourable Mr Justice Kumleben

In the matter between **Hermanus Louw van Niekerk**, Applicant and **Mobeni Armature Winders (Pty) Ltd**, Respondent

Upon the Motion of Counsel for the Applicant and upon reading the Notice of motion and the other documents filed of record:

It is Ordered:

That Mobeni Armature Winders (Proprietary) Limited and all other interested parties be and are hereby called upon to show cause, if any, before this Honourable Court at 09h30 or as soon thereafter as Counsel may be heard on the 15th June 1984, why the Respondent should not be wound up.

That this order operates as a provisional order for the winding up of the Respondent pending the return day hereof.

That this order and a copy of the application be served forthwith on the company at its registered office at 48 Bruning Place, Jacobs, Durban, Natal and that the order be published on or before the 8th of June 1984 once in the *Government Gazette* and once in a daily newspaper published and circulating in Durban.

By Order of the Court.—B. A. Povey, Registrar.

TERSYDESTELLINGS EN AFWYSINGS VAN AANSOEKE

Kennis word hiermee deur die Meesters van die Hooggeregshof van Suid-Afrika, soos vermeld, gegee van die tersydestelling van voorlopige bevel van sekwestrasie/likwidasië en die afwysing van aansoeke.

Die inligting word verstrek in die volgorde: Boedelnommer; die applikant; die verweerder; die datum van uitreiking van die voorlopige bevel; die Afdeling van die Hooggeregshof; die datum van die afwysingsbevel.

SUPERSESIONS AND DISCHARGE OF PETITIONS

Notice is hereby given by the Masters of the Supreme Court of South Africa, as stated, of the supersession of provisional orders of sequestration/liquidation and the discharge of petitions.

The information is given in the following order: Estate number; the applicant; the respondent; the date of the provisional order granted; the Supreme Court Division; the date of the discharge order.

E80/84—**E.P. Building Agencies (Proprietary) Limited**, Applicant; **Petronella Elizabeth Langenhoven**, an adult female, a public mercatrix, married out of community of property with the exclusion of the marital power to her husband, Danie Langenhoven, presently of Mondplaas, Humansdorp, Respondent; 13/3/84, South-Eastern Cape Local; 8/5/84.

N79/84—**Heinrich Paul Gerhard Volker**, Applicant; **Richard Eberhardt South Africa (Pty) Limited**, Respondent; 14/2/84, Durban and Coast Local; 15/5/84.

N192/84—**Litespec Africa (Pty) Limited**, Applicant; **Boland Textiles (Pty) Limited**, Respondent; 5/4/84, Natal Provincial; 17/5/84.

T1088/83—**Albert Ruskin, N.O.**, Applicant; **TV Entertainment (Pty) Ltd**, Respondent; 9/9/81, Transvaal Provincial; 1/5/84.

T2199/83—**Kolumbia Metals (Pty) Limited**, *Ex parte*; 13/12/83, Transvaal Provincial; 17/4/84.

T738/84—**Agri-Lyon Saadmaatskappy (Edms.) Beperk**, Applikant *ex parte* aansoek; 10/4/84, Transvaalse Provinsiale; 1/5/84.

T548/84—**Petrus Johannes Bezuidenhout**, Applikant, **Harry Butler Vorster**, Respondent; 13/3/83, Transvaalse Provinsiale; 10/4/84.

T588/83—**Leslie Cohen**, Applikant; **G & N Huide en Velle (Edms.) Beperk**, Respondent; 15/3/83, Transvaalse Provinsiale; 3/4/84.

T717/84—**Johan Diederick Aucamp**, Applikant; **Hendrik Willem Koen**, Respondent; 20/3/84, Transvaalse Provinsiale; 17/4/84.

T123/84—**Orez (Pty) Limited**, Applicant; **Pringles Electrical Services (Pty) Limited**, Respondent; 24/1/84, Witwatersrand Local; 15/5/84.

T1941/83—*Ex parte*, **Didakta S.A. (Pty) Ltd**, Applicant; 1/11/83, Witwatersrand Local; 8/5/84.

**GEREGTELIKE EN ANDER OPENBARE VERKOPE
SALES IN EXECUTION AND OTHER PUBLIC SALES****GEREGTELIKE VERKOPE • SALES IN EXECUTION****TRANSVAAL**

Case 5479/82

IN THE MAGISTRATE'S COURT FOR THE DISTRICT OF KEMPTON PARK HELD AT KEMPTON PARK

In the matter between **Standard Credit Corp Ltd**, Plaintiff, and **D. G. Scheepers**, Defendant

In pursuance of a Judgment granted in the Magistrate's Court, and a Warrant of Execution, dated the 10th day of May 1983, issued by the Court at Kempton Park, the following property will be sold in execution by the Messenger of the Court at the Magistrate's Court, Monument Road, Kempton Park, to the highest bidder, on the 28th day of June 1984 at 11h00:

Erf 800, Birch Acres Extension 2, Registration Division I.R., Transvaal, measuring 915 square metres, known as 18 Winterkoring Avenue, Birch Acres.

Conditions of sale:

1. The property shall be sold without reserve and to the highest bidder and shall be subject to the terms and conditions of the Magistrate's Court Act and Rules thereunder of the Title Deed, insofar as these are applicable.

2. The following improvements on the property are reported, but nothing is guaranteed:

Dwelling house and outbuildings.

3. *Terms:* The purchase price shall be paid as to 10 % thereof on the day of sale to the Messenger of the Court, and the unpaid balance thereof, together with interest thereon to date of registration of transfer at the rate of 11 % per annum shall within thirty (30) days be paid or secured by a Bank or Building Society Guarantee.

4. *Conditions:* The full conditions of sale may be inspected at the offices of the Messenger of the Court at Kempton Park.

H. A. Welgemoed, for Botha Massyn & McKenzie, Plaintiff's Attorneys, Botha Building, 23 Central Avenue, Kempton Park.

IN DIE HOOGGEREGSHOF VAN SUID-AFRIKA
(Witwatersrandse Plaaslike Afdeling)

In die saak tussen **Die Trust Bank van Afrika Beperk**, Eiser, en **Gert Lodewyk Isak Kruger**, Verweerder

Ingevolge 'n Vonnis van die Hooggeregshof van Suid-Afrika (Witwatersrandse Plaaslike Afdeling), gedateer 10 November 1981 en 'n Laasbrief vir Beslaglegging, gedateer 22 Julie 1983, sal die volgende eiendom in eksekusie verkoop word op Vrydag, 29 Junie 1984 om 10h00, te die kantore van die Adjunk-Balju, Panoramagebou, Kamer 13, Charl Cilliersstraat 55, Alberton, naamlik:

Erf 421, Brackendowns Dorpsgebied, Registrasie Afdeling I.R., Transvaal, groot 1 000 (een duisend) vierkante meter, gehou kragtens Akte van Transport, No. T 2102/1983, gedateer 14 Februarie 1983.

Bowkeriastraat 24, Brackendowns.

Die eiendom word verkoop onderhewig aan die bepalinge van die Groepsgebiedewet en tien persent (10 %) van die koopprys is betaalbaar by besluiting van die koopvoorenkoms en die balans teen registrasie van Transport aan die Koper moet verseker word deur 'n aanvaarbare waarborg wat aan die Adjunk-Balju voorsien moet word binne veertien (14) dae vanaf datum van verkoping. Die verkoping is verder onderhewig aan die bepalinge van Hofreël 46 van die Reëls van bogenoemde Agbare Hof.

Die volle voorwaardes van die Eksekusieverkoping wat op die Koper bindend sal wees sal voor die verkoping uitgelees word en kan gedurende kantoorure nagegaan word by die Adjunk-Balju van Alberton te Panoramagebou, Kamer 13, Charl Cilliersstraat 55, Alberton.

Aldus geteken te Johannesburg hierdie 15de dag van Mei 1984.

Louisa Fourie, Prokureur namens Eiser, Negende Verdieping, National Boardgebou, Pritchardstraat 94, Posbus 93, Johannesburg.

Case 16192/1983

In the matter between **South African Permanent Building Society**, Plaintiff, and **Petronella Hendrena Whittal**, Defendant

In execution of a Judgment of the Supreme Court of South Africa (Witwatersrand Local Division) in the above-mentioned suite, a sale without reserve will be held at the offices of the Deputy Sheriff, 131 Marshall Street, Johannesburg, on Thursday, the 28th day of June 1984 at 10 o'clock in the forenoon, of the undermentioned property of the Defendant on the Conditions to be read out by the Auctioneer at the time of the sale and which conditions may be inspected at the offices of the Deputy Sheriff, Johannesburg, prior to the sale:

Certain Erf 2512, Glenvista Extension 5 Township, Registration Division I.R., Transvaal, being 121 Mount Pellan Drive, Glenvista Extension 5, measuring 1 592 (one thousand five hundred and ninety two) square metres.

The following information is furnished *re* the improvements, though in this respect nothing is guaranteed:

"Carport, servant's room, servant's toilet, swimming pool, paved driveway, tiled roof, lounge, diningroom, kitchen, scullery, 3 bedrooms (en suite), bathroom and toilet".

Terms: 10 % (ten per centum) of the purchase price in cash on the day of the sale, the balance payable against registration of transfer, to be secured by a Bank or Building Society or other acceptable guarantee to be furnished within 14 (fourteen) days from the date of sale. Auctioneer's charges, payable on the day of the sale, to be calculated as follows:

5 % (five per centum) on the proceeds of the sale up to a price of R10 000,00 (ten thousand rand) and thereafter 2½ % (two and a half per centum) up to a maximum fee of R5 000,00 (five thousand rand). Minimum charges R20,00 (twenty rand).

Dated at Johannesburg on the 2nd day of May 1984.

E. F. K. Tucker Nupen & Goodman Inc., Plaintiff's Attorneys, 48th Floor, Carlton Centre, Commissioner Street, Johannesburg.

Case 82793/83

IN THE MAGISTRATE'S COURT FOR THE DISTRICT OF JOHANNESBURG HELD AT JOHANNESBURG

In the matter between **Sandton Finance (Pty) Limited**, Plaintiff, and **Barbare Susanna Maloney**, Defendant

In pursuance of a Judgment in the Court of the Magistrate of Johannesburg and a Warrant of Execution, dated the 23rd day of January 1984, the following property will be sold in execution on the 29th day of June 1984, in front of the court-house, Johannesburg East, at 10 a.m., to the highest bidder:

Certain Erf 1086, Bezuidenhout Valley Township, Registration Division I R, Transvaal, measuring 495 square metres, known as 65 10th Avenue, Bezvalley, Johannesburg.

Conditions of sale:

1. The property shall be sold without reserve and to the highest bidder and shall be subject to the terms and conditions of the Magistrate's Court Act and the Rules made thereunder, and of the title deeds, insofar as these are applicable.

2. The following improvements on the property have been reported, but nothing guaranteed:

A dwelling house with usual outbuildings.

3. **Terms:** The Purchase Price shall be paid as to ten per centum (10 %) thereof on the signing of the Conditions of Sale, and the unpaid balance together with interest thereon at the rate stipulated in the First Mortgage Bond registered against the property to date of payment, within fourteen (14) days, to be paid or secured by an approved Bank or Building Society guarantee.

4. **Conditions:** The full conditions of sale, which will be read by the Messenger of the Court, Johannesburg, immediately prior to the sale, may be inspected at the office and at the office of Bredell Murray & Ronbeck, 17th Floor, Kine Centre, Commissioner Street, Johannesburg.

Dated at Johannesburg this 1st day of May 1984.

E. A. Ronbeck, for Bredell Murray & Ronbeck, Plaintiff's Attorneys, 17th Floor, Kine Centre, Commissioner Street, Johannesburg.

Saak 6173/83

IN DIE LANDDROSHOF VIR DIE DISTRIK VAN VANDERBIJLPARK GEHOU TE VANDERBIJLPARK

In die saak tussen **S A Permanente Bouvereniging**, Eiser, en **Frederik Wynand van Zyl**, Verweerder

Ingevolge 'n uitspraak van bogemelde Agbare Hof en 'n Laasbrief vir Eksekusie, gedateer 23 November 1983, sal die volgende onroerende eiendom, wat uitwinbaar verklaar is, in eksekusie verkoop word aan die hoogste bieder op Vrydag, die nege en twintigste dag van Junie 1984 om 10h00, te die Landdroskantoor, Vanderbijlpark, tewete:

Sekere Erf 331, geleë in die Vanderbijlpark Central West 4 Dorpsgebied, Registrasie Afdeling I.Q., Transvaal, groot 690 vierkante meter.

Verkoopsvoorwaardes:

1. Die eiendom sal verkoop word aan die hoogste bieder en die verkoping sal onderworpe wees aan die bepalings van Art. 66 van die Landdroshowewet, No. 32 van 1944, soos gewysig en die regte van verbandhouders en ander preferente krediteure.
2. Die koopprys sal betaalbaar wees soos volg:
 - (a) 10 % (tien persent) van die koopprys in kontant op die dag van die verkoping of deur middel van 'n erkende Bank- of Bougenootskapswaarborg gelewer op die dag van die verkoping, welke waarborg betaalbaar moet wees teen registrasie van transport in die naam van die koper, vry van kommissie te Vanderbijlpark.
 - (b) Die balans is betaalbaar in kontant binne veertien dae vanaf die datum van verkoping of deur middel van 'n erkende Bank- of Bougenootskapswaarborg gelewer te word binne veertien dae na die dag van verkoping en welke waarborg vry van kommissie aan die Geregsbode te Vanderbijlpark, betaalbaar moet wees teen registrasie van transport van die eiendom in die naam van die koper.
3. Die volledige verkoopsvoorwaardes lê ter insae by die Geregsbode te Vanderbijlpark, en by die Eiser se Prokureurs, en sal deur die Geregsbode voor die verkoping uitgelees word.
4. Die eiendom word verkoop onderworpe aan die terme en titelvoorwaardes van die eiendom.
Geteken te Vanderbijlpark, hierdie 14de dag van Mei 1984.
Rooth & Wessels, Prokureurs vir Eiser, Concordegebou, Attie Fouriestraat, Vanderbijlpark.

Saak 3672/83

IN DIE LANDDROSHOF VIR DIE DISTRIK VAN WITBANK GEHOU TE WITBANKIn die saak tussen **Funds Elect (Edms.) Bpk.**, Eiser, en **Petrus Jacobus Cornelius**, Verweerder

Ingevolge 'n Vonnis toegestaan in bogemelde Agbare Hof en 'n Lasbrief vir Eksekusie, gedateer 12 September 1983, sal die vaste eiendom hierin genoem, waarop beslag gelê is deur die Geregsbode, Witbank, in Eksekusie verkoop word voor die Landdroskantore, Dellvillestraat, Witbank, op Vrydag, die 15de dag van Junie 1984 om 10h00:

Erf 245, geleë te Jellicoestraat, Witbank-uitbreiding 1.

Die eiendom synde 'n woonhuis en buitegeboue word "voetstoots" verkoop aan die hoogste bieder wie alle agterstallige belastings moet betaal, rente op Eiser se eis en al die verkoopsvoorwaardes moet nakom, wat ter insae lê by die Geregsbode, Witbank, en die Prokureurs vir Eiser, Van Heerden Marais & Brummer Ingelyf, Disagebou, Escombelaan, Witbank.

Gedateer te Witbank op die 17de dag van Mei 1984.

Van Heerden Marais & Brummer Ingelyf, Derde Verdieping, Disagebou, Posbus 6, Witbank.

Saak 19113/83

IN DIE HOOGGEREGSHOF VAN SUID-AFRIKA

(Transvaalse Provinsiale Afdeling)

In die saak tussen **Volkskas Beperk**, Eiser, en **Marthinus Nicolaas Kruger**, Verweerder

Ter uitvoerlegging van 'n Vonnis in die bogemelde Agbare Hof, gedateer die 13de dag van Desember 1983, en 'n Lasbrief vir Eksekusie word die volgende eiendom in eksekusie verkoop op die 22ste dag van Junie 1984 om 10h00, by die Landdroskantoor, te Delareyville, aan die hoogste bieder:

Resterende Gedeelte van Gedeelte 1 van die plaas Strydpan 276, Registrasie Afdeling I.Q., Transvaal, groot 119,6242 hektaar.

Die reserweprys is R87 000,00.

Die eiendom bestaan uit onbewoonbare bouvallige plaasopstal.

Terme en voorwaardes:**Terme:**

Die koopprys sal wees 10 % (tien persent) daarvan by verkoping en die balans moet binne 10 dae verseker word by wyse van 'n Bank- of Bouvereniging waarborg.

Voorwaardes:

Die volle voorwaardes van verkoping wat deur die Adjunk-Balju van Delareyville, onmiddellik voor die verkoping uitgelees sal word, ter insae lê by die kantoor van die Adjunk-Balju, p/a Herman du Plessis & Seun, Generaal Delareystraat, Delareyville.

Geteken te Pretoria op hierdie dag van Mei 1984.

Tim du Toit & Kie. Ingelyf, Prokureurs vir Eiser, Volkskasgebou 1920, Strijdomplein, Posbus 834, Pretoria, 0001.

Case 41917/1983

IN THE MAGISTRATE'S COURT FOR THE DISTRICT OF JOHANNESBURG HELD AT JOHANNESBURGIn the matter between **Sandton Finance (Pty) Limited**, Plaintiff, and **William Charles Thiel**, Defendant

In pursuance of a Judgment in the Court of the Magistrate of Johannesburg and a Warrant of Execution, dated the 4th day of July 1983, the following property will be sold in execution on the 29th day of June 1984, at the Magistrate's Court, Fochville, at 10 a.m., to the highest bidder:

Certain Remaining Extent of Erf 1031, situate in the Township of Fochville, Registration Division I.Q., Transvaal, measuring 2,151 square metres, known as 11 Kerk Street, Fochville.

Conditions of sale:

1. The property shall be sold without reserve and to the highest bidder and shall be subject to the terms and conditions of the Magistrate's Court Act and the Rules made thereunder, and of the title deeds, insofar as these are applicable.
2. The following improvements on the property have been reported, but nothing guaranteed:
A dwelling house with usual outbuildings.
3. **Terms:** The Purchase Price shall be paid as to ten per centum (10 %) thereof on the signing of the Conditions of Sale, and the unpaid balance together with interest thereon at the rate stipulated in the First Mortgage Bond registered against the property to date of payment, within fourteen (14) days, to be paid or secured by an approved Bank or Building Society guarantee.

4. *Conditions*: The full conditions of sale, which will be read by the Messenger of the Court, Fochville, immediately prior to the sale, may be inspected at his office and at the office of Bredell Murray & Ronbeck, 17th Floor, Kine Centre, Commissioner Street, Johannesburg.

Dated at Johannesburg this 4th day of May 1984.

E. A. Ronbeck, for Bredell Murray & Ronbeck, Plaintiff's Attorneys, 17th Floor, Kine Centre, Commissioner Street, Johannesburg.

Case 3572/1984

IN THE MAGISTRATE'S COURT FOR THE DISTRICT OF JOHANNESBURG HELD AT JOHANNESBURG

In the matter between **Sandton Finance (Pty) Limited**, Plaintiff, and **Gavin Leslie Frank**, Defendant

In pursuance of a Judgment in the Court of the Magistrate of Johannesburg and a Warrant of Execution, dated the 3rd day of February 1984, the following property will be sold in execution on the 29th day of June 1984, in front of the court-house, at 10 a.m., to the highest bidder:

Certain Erf 2710, Lenasia Extension 2 Township, Registration Division I.Q., Transvaal, measuring 622 square metres, known as 47 Agapanthus Avenue, Greyville, Lenasia, Johannesburg.

Conditions of sale:

1. The property shall be sold without reserve and to the highest bidder and shall be subject to the terms and conditions of the Magistrate's Court Act and the Rules made thereunder, and of the title deeds, insofar as these are applicable.

2. The following improvements on the property have been reported, but nothing guaranteed:

A dwelling house with usual outbuildings.

3. *Terms*: The Purchase Price shall be paid as to ten per centum (10 %) thereof on the signing of the Conditions of Sale, and the unpaid balance together with interest thereon at the rate stipulated in the First Mortgage Bond registered against the property to date of payment, within fourteen (14) days, to be paid or secured by an approved Bank or Building Society guarantee.

4. *Conditions*: The full conditions of sale, which will be read by the Messenger of the Court, Johannesburg, immediately prior to the sale, may be inspected at his office and at the office of Bredell Murray & Ronbeck, 17th Floor, Kine Centre, Commissioner Street, Johannesburg.

Dated at Johannesburg this 1st day of May 1984.

E. A. Ronbeck, for Bredell Murray & Ronbeck, Plaintiff's Attorneys, 17th Floor, Kine Centre, Commissioner Street, Johannesburg.

Case 7462/82

IN THE MAGISTRATE'S COURT FOR THE DISTRICT OF BENONI HELD AT BENONI

In the matter between **Standard Credit Corporation Limited**, Plaintiff, and **Francois Phillipus Wright**, Defendant

In pursuance of a judgment of the above Honourable Court and Writ of Execution, the undermentioned property will be sold in execution by the Messenger of the Court, Benoni, on Friday, the 15th day of June 1984 at 11h00 in the forenoon, in front of the Magistrate's Court, Benoni, to the highest bidder:

Certain Erf 2398, Benoni Township, situate at 52 Second Avenue, Northmead, measuring 1 193 (one thousand one hundred and ninety three) square metres.

The following improvements subsist on the property, but no guarantee thereto is given:

Dwelling house with outbuildings.

Material conditions of sale:

1. The property shall be sold to the highest bidder, without reserve and the sale shall be subject to the provisions of the Magistrate's Court Act, No. 32 of 1944, as amended, and the Rules framed thereunder.

2. The sale will be subject to payment of 10 % of the purchase price on the date of sale, a bank or building society guarantee to be furnished within 14 (fourteen) days of date hereof, securing payment of the balance.

The full conditions of sale which will be read out immediately prior to the sale, may be inspected at the office of the Messenger of the Court, Benoni.

Dated at Benoni, this 4th day of May 1984.

Slomowitz Dobie Smith & Myburgh Inc., 65 Bedford Avenue, Benoni.

IN THE MAGISTRATE'S COURT FOR THE DISTRICT OF BENONI HELD AT BENONI

In the matter between **Standard Credit Corporation Limited**, Plaintiff, and **Wilhelmina Christiana Jacobs**, Defendant

In pursuance of a judgment of the above Honourable Court and Writ of Execution, the undermentioned property will be sold in execution by the Messenger of the Court, Benoni, on Friday, the 15th day of June 1984 at 11h00 in the forenoon, in front of the Magistrate's Court, Benoni, to the highest bidder:

Certain Erf 458, Benoni Township, situate at 104 Kemston Avenue, Benoni, measuring 595 (five hundred and ninety five) square metres.

The following improvements subsist on the property, but no guarantee thereto is given:

Dwelling house with outbuildings.

Material conditions of sale:

1. The property shall be sold to the highest bidder, without reserve and the sale shall be subject to the provisions of the Magistrate's Court Act, No. 32 of 1944, as amended, and the Rules framed thereunder.

2. The sale will be subject to payment of 10 % of the purchase price on the date of sale, a bank or building society guarantee to be furnished within 14 (fourteen) days of date hereof, securing payment of the balance.

The full conditions of sale which will be read out immediately prior to the sale, may be inspected at the office of the Messenger of the Court, Benoni.

Dated at Benoni, this 2nd day of May 1984.

Slomowitz Dobie Smith & Myburgh Inc., 65 Bedford Avenue, Benoni.

Case 8306/82

IN THE MAGISTRATE'S COURT FOR THE DISTRICT OF BENONI HELD AT BENONI

In the matter between **Standard Credit Corporation Limited**, Plaintiff, and **Clayman Persad**, Defendant

In pursuance of a judgment of the above Honourable Court and Writ of Execution, the undermentioned property will be sold in execution by the Messenger of the Court, Benoni, on Friday, the 15th day of June 1984 at 11h00 in the forenoon, in front of the Magistrate's Court, Benoni, to the highest bidder:

Certain Erf 98, Actonville Township, situate at 98 Montague Street, Actonville, measuring 625 (six hundred and twenty five) square metres.

The following improvements subsist on the property, but no guarantee thereto is given:

Dwelling house with outbuildings.

Material conditions of sale:

1. The property shall be sold to the highest bidder, without reserve and the sale shall be subject to the provisions of the Magistrate's Court Act, No. 32 of 1944, as amended, and the Rules framed thereunder.

2. The sale will be subject to payment of 10 % of the purchase price on the date of sale, a bank or building society guarantee to be furnished within 14 (fourteen) days of date hereof, securing payment of the balance.

The full conditions of sale which will be read out immediately prior to the sale, may be inspected at the office of the Messenger of the Court, Benoni.

Dated at Benoni, this 4th day of April 1984.

Slomowitz Dobie Smith & Myburgh Inc., 65 Bedford Avenue, Benoni.

Saak 861/84

IN DIE LANDDROSHOF VIR DIE DISTRIK VAN ERMELO GEHOU TE ERMELO

In die saak tussen **Saambou-Nasionale Bouvereniging**, Eiser, en **Judith Margaretha Cornelia van den Berg**, Verweerderes

Ingevolge uitspraak van bogemelde Agbare Hof, gedateer die 18de April 1984 en Lasbrief vir Geregtelike Verkoop, gedateer die 18de April 1984, word die hiernavermelde eiendom om 10h00, op die 29ste Junie 1984, voor die landdroskantoor, Van Riebeeckstraat, Ermelo, geregtelik verkoop aan die persoon wat die hoogste bod maak, naamlik:

Erf 4015, geleë in die dorp Ermelo, Uitbreiding 17, Registrasie Afdeling I.T., Transvaal, groot 1 361 (eenduisend driehonderd een en sestig) vierkante meter.

Die eiendom is verbeter.

Voorwaardes:

Volledige verkoopsvoorwaardes wat onmiddellik voor die veiling deur die Geregsbode van Ermelo uitgelees sal word, lê in sy kantoor ter insae en is die belangrikste bepalinge daarvan die volgende:

(a) Die koper moet onmiddellik nadat die bod op hom toegeslaan is 10 % (tien persent) van die koopprys aan die Geregsbode betaal en vir die balans van die koopprys moet die koper 'n bank of bougenootskapwaarborg aan die Geregsbode van Ermelo lewer binne sestig (60) dae na datum van verkoping.

(b) Die koper sal verplig wees om onmiddellik nadat die bod op hom toegeslaan is, die verkoopsvoorwaardes te onderteken.

(c) Die koper sal aanspreeklik wees vir hereregte, transportkoste, en agterstallige belastinge indien enige, asook ander uitgawes wat nodig is om transport te laat geskied.

J. J. van der Wath, vir Bekker Brink & Brink, Prokureurs vir Eiser, Kerkstraat 60, Posbus 73, Unitedgebou, Ermelo.

Case 557/84

IN THE MAGISTRATE'S COURT FOR THE DISTRICT OF BENONI HELD AT BENONI

In the matter between **South African Permanent Building Society**, Plaintiff, and **Abdul Gaffoor Ebrahim**, Defendant

In pursuance of a Judgement in the Court of the Magistrate of Benoni, and Writ of Execution, dated the 15th day of March 1984, the property listed hereunder will be sold in Execution on Friday, the 22nd day of June 1984 at 11 o'clock in the forenoon, in front of the Magistrate's Court, Harpur Avenue, Benoni, to the highest bidder:

Portion 19 of Erf 1512, Actonville Extension 3, Township Registration Division I.R., Transvaal, measuring 460 (four hundred and sixty) square metres, known as 19 Prem Crescent, Actonville, Benoni.

No warranty or undertaking is given in relation to the nature of the improvements, which are described as follows:

Main building: Brick under tiles, lounge, dining room, 3 bedrooms, 2 bathrooms.

Outbuildings: Garage and toilet.

The material conditions of sale are:

(a) The sale will be held by Public Auction and without reserve and will be "voetstoots".

(b) Immediately after the sale the Purchaser shall sign the Conditions of Sale which can be inspected at the Messenger of the Court's Office, Benoni.

(c) The Purchaser shall pay all amounts necessary to obtain transfer of the property, including all costs of transfer, transfer duty, rates, taxes, licenses, sanitary fees, interest, etc.

(d) The Purchase price shall be paid as to 10 % (ten per centum) thereof or R500,00 (five hundred rand) whichever is the greater, on the day of the sale and the unpaid balance, together with interest on the full amount of the Judgment Creditor's Claim at the rate of 19,75 % (nineteen comma seven five per centum) per annum to date of payment, within fourteen days to be paid or secured by a Bank or Building Society guarantee.

(e) The property shall be sold subject to any existing tenancy.

(f) Failing compliance with the provisions of the Conditions of Sale, the Purchaser shall forfeit for the benefit of the Execution Creditor the deposit referred to in (d) above, without prejudice to any claim against him for damages.

Dated at Benoni on this 19th day of April 1984.

H. J. Falconer, for A. E. Cook, Cook & Falconer, Attorney for Execution Creditor, Second Floor, Permanent Building, 47 Princess Avenue, P.O. Box 52, Benoni.

Case 41923/83

IN THE MAGISTRATE'S COURT FOR THE DISTRICT OF JOHANNESBURG HELD AT JOHANNESBURG

In the matter between **Sandton Finance (Pty) Limited**, Plaintiff, and **Z. Kasic**, Defendant

In pursuance of a Judgment in the Court of the Magistrate of Johannesburg and a Warrant of Execution, dated the 4th day of July 1983, the following property will be sold in execution on the 3rd day of July 1984 in front of the Magistrate's Court, President Street, Germiston, at 11.30 a.m., to the highest bidder:

Certain Undivided half share of Portion 6 of Lot 560, Eastleigh Township, measuring 991 square metres, known as 1 Jordaan Drive, Eastleigh, Edenvale.

Conditions of sale:

1. The property shall be sold without reserve and to the highest bidder and shall be subject to the terms and conditions of the Magistrate's Court Act and the Rules made thereunder, and of the title deeds, insofar as these are applicable.

2. The following improvements on the property have been reported, but nothing guaranteed:

A dwelling house with usual outbuildings.

3. *Terms:* The Purchase Price shall be paid as to ten per centum (10 %) thereof on the signing of the Conditions of Sale, and the unpaid balance together with interest thereon at the rate stipulated in the First Mortgage Bond registered against the property to date of payment, within fourteen (14) days, to be paid or secured by an approved Bank or Building Society guarantee.

4. *Conditions:* The full conditions of sale, which will be read by the Messenger of the Court, Germiston, immediately prior to the sale, may be inspected at his office and at the office of Bredell Murray & Ronbeck, 17th Floor, Kine Centre, Commissioner Street, Johannesburg.

Dated at Johannesburg this 26th day of April 1984.

E. A. Ronbeck, for Bredell Murray & Ronbeck, Plaintiff's Attorneys, 17th Floor, Kine Centre, Commissioner Street, Johannesburg.

Case 1270/1984

IN THE MAGISTRATE'S COURT FOR THE DISTRICT OF GERMISTON HELD AT GERMISTON

In the matter between **Allied Building Society**, Plaintiff, and **Beatrice Maude Garrod**, Defendant

In pursuance of a Judgment in the Court of the Magistrate of Germiston, and Writ of Execution, dated the 12th March 1984, the property listed herein will be sold in execution on Tuesday, the 3rd July 1984 at 11.30 a.m., in front of the Magistrate's Court, President Street entrance, Germiston, to the highest bidder:

Remaining Extent of Lot 145, Klippoortjie Agricultural Lots Township, Registration Division I.R., Transvaal, situate on 59 Beacon Road, Lambton, measuring 2 428 square metres.

The Judgment Creditor described the improvements on the property as set out hereunder, but no warranties are given in respect thereof:

Improvements:

Detached double and single storey dwelling consisting of entrance hall, lounge, dining room, T.V. room, sewing room, three bedrooms, plus cloak room and w.c. Constructed of brick with a tile roof.

Outbuildings: Double garage of brick with a tile roof which is attached to main building with servant's room and w.c. which are separated from the main building.

Terms: The purchase price shall be paid as to ten per cent (10 %) thereof on the day of the sale and the unpaid balance, together with interest thereon to date of registration of transfer shall be paid or secured by a Bank or Building Society Guarantee within fourteen (14) days of the date of sale to the Messenger of the Court.

The Conditions of Sale, which will be read immediately prior to the sale, may be inspected at the office of the Messenger of the Court, Germiston.

Wright Rose-Innes Louw & Wise, Allied Building, 170 Meyer Street, Germiston.

Case 1269/1984

IN THE MAGISTRATE'S COURT FOR THE DISTRICT OF GERMISTON HELD AT GERMISTON

In the matter between **Allied Building Society**, Plaintiff, and **Paul Abraham Willemse**, Defendant

In pursuance of a Judgment in the Court of the Magistrate of Germiston, and Writ of Execution, dated the 12th March 1984, the property listed herein will be sold in execution on Tuesday, the 3rd July 1984 at 11.30 a.m., in front of the Magistrate's Court, President Street entrance, Germiston, to the highest bidder:

Erf 453, Lambton Extension 1 Township, Registration Division I.R., Transvaal, situate on 39 Ninth Avenue, Lambton, measuring 1 983 square metres.

The Judgment Creditor described the improvements on the property as set out hereunder, but no warranties are given in respect thereof:

Improvements:

Detached single storey dwelling consisting of six rooms with study, kitchen, bathroom and w.c. Constructed of brick with tile roof.

Outbuildings: Double garage, servant's room and w.c. of brick with an iron roof.

Terms: The purchase price shall be paid as to ten per cent (10 %) thereof on the day of the sale and the unpaid balance, together with interest thereon to date of registration of transfer shall be paid or secured by a Bank or Building Society Guarantee within fourteen (14) days of the date of sale to the Messenger of the Court.

The Conditions of Sale, which will be read immediately prior to the sale, may be inspected at the office of the Messenger of the Court, Germiston.

Wright Rose-Innes Louw & Wise, Allied Building, 170 Meyer Street, Germiston.

Saak 7403/82

IN DIE LANDDROSHOF VIR DIE DISTRIK VAN VANDERBIJLPARK GEHOU TE VANDERBIJLPARK

In die saak tussen **Unifed Bouvereniging**, Eksekusieskuldeiser, en **D. M. Zide**, Eksekusieskuldenaar

Ingevolge 'n vonnis van die Landdroshof vir die distrik van Vanderbijlpark, gedateer die 4de November 1982, en 'n Lasbrief vir Eksekusie, gedateer die 27ste Oktober 1982, sal die reg op huurpag ten opsigte van die volgende eiendom, nl:

Erf 19379, tesame met alle strukture en geboue in die dorpsgebied Bethela Woongebied in die jurisdiksie van die hoof kommissaris vir die Oranje-Vrystaat (Oranje Vaaldriehoek), gehou te Reg van Huurpag No. 19379/98, gedateer 30 Oktober 1981.

Die gebied beskryf is vir okkupasie deur lede van die Swart- en Gekleurde groep alleenlik, op Vrydag, die 22ste Junie 1984 om 10h00 vm., te Landdroshofgebou, Vanderbijlpark, in eksekusie verkoop word.

Die reg op huurpag word verkoop onderhewig aan die bepalings van die Groepsgebiedewet en 10 % (tien persent) van die koopprys is betaalbaar by sluiting van die Kooporeenkoms en die balans teen registrasie van transport aan die Koper, moet verseker word deur 'n aanvaarbare waarborg wat aan die Geregsbode voorsien moet word binne 14 (veertien) dae vanaf datum van verkoping. Die verkoping is onderhewig aan Artikel 66 van die Wet op Landdroshowe No. 32 van 1944, soos gewysig. Die volle voorwaardes van die eksekusieverkoping wat op die Koper bindend sal wees, sal voor die verkoping uitgelees word en kan gedurende kantoorure nagegaan word by die kantoor van die Geregsbode, Vanderbijlpark en by die kantore van Eiser se Prokureurs.

Geteken te Vanderbijlpark hierdie 4de dag van Mei 1984.

Raubenheimer Theron & Van der Merwe, Prokureurs vir Eiser, Unitedgebou 1, Eric Louwstraat, Posbus 581, Vanderbijlpark, 1900.

Case 461/84

IN THE MAGISTRATE'S COURT FOR THE DISTRICT OF BRAKPAN HELD AT BRAKPAN

In the matter between **Allied Building Society**, Plaintiff, and **S. W. Pretorius**, Defendant

In pursuance of a judgment in the Court of the Magistrate of Brakpan, dated the 12th day of February 1984, and the Writ of Execution, dated the 16th day of February 1984, the following will be sold in execution without reserve to the highest bidder on the 22nd June 1984, at 11.00 a.m., at the Magistrate's Court, Offices of the Messenger, Prince George Avenue, Brakpan:

Certain Erf 312, in the Township of Brenthurst, Registration Division I.R., Transvaal, measuring 833 (eight hundred and thirty three) square metres, held by the Defendant under Deed of Transfer No. T9097/81.

Improvements:

Terms and conditions:

1. *Terms:* The Purchase price shall be paid as to 10 per centum (10 %) thereof on the day of the sale and the unpaid balance within fourteen days shall be paid or secured by a Bank or Building Society guarantee.

2. *Conditions of sale:* The full conditions of sale may be inspected in the Messenger's Office.

Dated at Brakpan this 3rd day of May 1984.

P. J. Cowling, for Trollip, Joubert, Cowling & Janeke, 125a Kingsway Avenue, Brakpan, 1540.

Case 3692/1983

In the matter between **South African Permanent Building Society**, Plaintiff, and **David Vanderberg Kahta**, Defendant

In execution of a judgement of the Supreme Court of South Africa (Witwatersrand Local Division) in the above-mentioned suit, a sale without reserve will be held at the offices of the Deputy Sheriff, 131 Marshall Street, Johannesburg, on Thursday, the 28th day of June 1984 at 10 o'clock in the forenoon, of the undermentioned property of the Defendant on the Conditions to be read out by the Auctioneer at the time of the sale and which Conditions may be inspected at the offices of the Deputy Sheriff, Johannesburg, prior to the sale:

Certain Erf 948, Auckland Park Township, Registration Division I.R., Transvaal, 26 Finsbury Avenue, Auckland Park, measuring 922 (nine hundred and twenty two) square metres.

The following information is furnished *re* the improvements, though in this respect nothing is guaranteed:

"Dwelling, 2 servant's rooms, servant's toilets, grass driveway, swimming pool, precast and stone wall around property, iron roof".

Terms: 10 % (ten per centum) of the purchase price in cash on the day of the sale; the balance payable against registration of transfer, to be secured by a Bank or Building Society or other acceptable guarantee to be furnished within 14 (fourteen) days from the date of sale. Auctioneer's charges, payable on the day of the sale, to be calculated as follows:

5 % (five per centum) on the proceeds of the sale up to a price of R10 000,00 (ten thousand rand) and thereafter 2½ % (two and a half per centum) up to a maximum fee of R5 000,00 (five thousand rand). Minimum charges R20,00 (twenty rand).

Dated at Johannesburg on the 7th day of May 1984.

E. F. K. Tucker Nupen & Goodman Inc., Plaintiff's Attorneys, 48th Floor, Carlton Centre, Commissioner Street, Johannesburg.

Saak 20877/83

IN DIE HOOGGEREGSHOF VAN SUID-AFRIKA
(Transvaalse Provinsiale Afdeling)

In die saak tussen **Christiaan Jacobus Louw**, Eiser, en **August Johannes Frederick de Koker**, Verweerder

Ingevolge uitspraak van die Hooggeregshof van Suid-Afrika (Transvaalse Provinsiale Afdeling) en Lasbrief tot Uitwinning, gedateer 6 Februarie 1984, sal die Adjunk-Balju, Vereeniging, op die 21ste dag van Junie 1984 om 10h00 vm., in die verkoopslokaal van Chase & Sons, Lesliestraat 16, Vereeniging, die ondervermelde eiendom verkoop aan die hoogste bieder:

Hoewe 482, Walker's Fruit Farms Landbouhoewes, Uitbr 1, Registrasie Afdeling I Q, Transvaal, groot 2,0819 hektaar, gehou deur verweerder kragtens Akte van Transport T58088/1980.

Die eiendom sal verkoop word met 'n reserweprys van R37 700,00 en bestaan uit die volgende verbeterings, ten opsigte waarvan egter geen waarborg gegee word nie:

'n Platdak twee-verdiepinghuis bestaande uit ses slaapkamers, ingangsportaal, sitkamer, eetkamer, T V kamer, drie badkamers met toilette, stoep, balkon, dubbel motorhuis met 'n badkamer en toilet. Sekere afrondingswerk soos loodgieterwerk en verfwerk moet aan hierdie gebou gedoen word.

Asook 'n platdak kothuis bestaande uit twee slaapkamers, sitkamer, kombuis en badkamer met toilet.

Water word verskaf uit 'n boorgat. Geen elektriese krag nie.

Die volledige verkoopsvoorwaardes sal onmiddellik voor die verkoping uitgelees word en kan nagegaan word by die Kartoor van die Adjunk-Balju, Overvaal, Krugerlaan, Vereeniging.

Geteken te Vereeniging op die 16de dag van Mei 1984.

H. B. Coetzer, Eiser se Prokureur, 42a Senator Markslaan, Posbus 2186, Vereeniging.

IN THE MAGISTRATE'S COURT FOR THE DISTRICT OF GERMISTON HELD AT GERMISTON

Between Natal Building Society, Plaintiff, and Jan Adriaan Mulder, Defendant

Pursuant to a Judgment granted by the above-named Honourable Court, dated 29th March 1984, and Warrant of Execution, dated 4th April 1984, the undermentioned property will be sold on the 3rd July 1984 at 11.30 a.m., in front of the Magistrate's Court, President Street, Germiston, to the highest bidder:

Certain Erf 532, in the Township of Sunnyridge, Registration Division I.R., Transvaal, measuring 744 (seven hundred and forty four) square metres, held under Deed of Transfer No. T 26596/1983, dated 23rd November 1983, Bond No. B 34855/1983, in favour of Natal Building Society, Germiston.

Improvements:

Residence comprising of brick walls, steel framed windows and iron roof. Lounge, 4 bedrooms, toilet, garage, dining room, 2 bathrooms with toilet, kitchen and servants room with toilet.

Terms and conditions: 10 % (ten per centum) of the Purchase Price on the date of sale and the balance together with interest thereon at the rate of 17,25 % (seventeen comma five per centum) per annum, plus all rates and taxes, shall be paid or secured by an approved Bank or Building Society Guarantee within 21 (twenty one) days of the date of sale.

Conditions of sale: The complete Conditions of Sale may be inspected at the Office of the Messenger of the Court, Germiston.

H. N. Krouse, vir H. N. Krouse, 209 Rutland Place, F. H. Odendaal Street, P.O. Box 38, Germiston.

Saak 4733/1984

IN DIE HOOGGEREGSHOF VAN SUID-AFRIKA
(Transvaalse Provinsiale Afdeling)

In die saak tussen E. C. Burger, Eiser, en Andries Everades Grundlingh, Verweerder

Kennis word hiermee gegee dat ingevolge 'n uitspraak van die Hooggeregshof van Suid-Afrika, Transvaalse Provinsiale Afdeling in bogenoemde saak op die 27ste dag van Maart 1984, en ter uitvoering van 'n Lasbrief tot Uitwinning sal die Adjunk-balju, Warmbad, op die 6de Julie 1984 om 10h00, te die Landdroskantore, Moffatstraat, Warmbad, verkoop:

Sekere Gedeelte 40 ('n gedeelte van Gedeelte 16) van die plaas Buiskop 464, Registrasie Afdeling K.R., Transvaal, groot 8,5656 hektaar.

Die eiendom is verbeter met 'n woonhuis en buitegeboue.

Die Koper moet 'n deposito van 10 % van die koopprys, Adjunkbaljufoeie en agterstallige belasting betaald op die dag van die verkoping, die balans betaalbaar teen transport en verseker te word deur 'n waarborg van 'n Bank- of Bouvereniging wat deur die Eiser se prokureur goedgekeur is, die waarborg aan die Adjunk-Balju binne 14 (veertien) dae na datum van die verkoping verstrekk te word.

Gemelde eiendom sal verkoop word op die voorwaardes wat uitgelees sal word deur die Adjunk-balju ten tye van die verkoping, welke voorwaardes nagegaan kan word by die kantoor van die Adjunk-balju, Warmbad.

Geteken te Pretoria op hierdie dag van Mei 1984.

Dyason, Odendaal & Van Eeden, Prokureurs vir Eiser, Leopontgebou, Tweede Verdieping, Kerkstraat-Oos 451, Pretoria.

Saak 7850/82

IN DIE LANDDROSHOF VIR DIE DISTRIK VAN ALBERTON GEHOU TE ALBERTON

In die saak tussen Die Trust Bank van Afrika Beperk, Eiser, en Jan Beaurain, Verweerder

Ten uitvoerlegging van 'n vonnis in die Hooggeregshof van Suid-Afrika, Witwatersrand Plaaslike Afdeling, toegestaan op die 14de dag van September 1982, en Lasbrief vir Eksekusie, gedateer die 28ste dag van Februarie 1983, sal die volgende eiendomme sonder reserwe in Eksekusie verkoop word aan die hoogste aanbieder op Vrydag, die 29ste dag van Junie 1984 om 10h00, by die kantore van die Geregsbode, Panoramagebou, Charl Cillierslaan 55, Alberton, naamlik:

Een halwe onverdeelde aandeel in sekere Erf 485, Alberton Dorpsgebied, Registrasie Afdeling I R, Transvaal (ook bekend as 21 Vyfde Laan, Alberton), groot 991 vierkante meter, gehou deur Jan Beaurain onder Akte van Transport No. T 10981/1978.

Sonering: Residensieel.

Daar is geen spesiale gebruiksvergunninge of vrystellings toegestaan in verband met hierdie erf nie.

Groepsgebiede wet: Blank.

Die Vonnis Skuldeiser beskryf die verbetering op die eiendom, sonder om dit te waarborg as volg:

Geen verbeterings op hierdie erf, lê standplaas, en

Een halwe onverdeelde aandeel in sekere Erf 487, Alberton Dorpsgebied, Registrasie afdeling I R, Transvaal (ook bekend as 23 Vyfde Laan, Alberton), groot 991 vierkante meter, gehou deur Jan Beaurain, onder Akte van Transport No. T 10981/1978.

Sonering: Residensieel.

Daar is geen spesiale gebruiksvergunninge of vrystellings toegestaan in verband met hierdie erf nie.

Groepsgebiede wet: Blank.

Die Vonnis Skuldeiser beskryf die verbeterings op die eiendom, sonder om dit te waarborg as volg:

Hoofgebou: Baksteen met sinkdak bestaande uit sitkamer, eetkamer, kombuis, 2 slaapkamers, badkamer en W.C.

Buitegeboue: Baksteen met sinkdak bestaande uit dubbel motorhuis, bediendekamer met badkamer en W.C.

Terme en voorwaardes van verkoping t.o.v. beide erwe:

1. *Terme:*

Die koopprys betaalbaar teen 10 % ten tye van die verkoping en die onbetaalde balans plus rente teen 16,25 % per annum tot datum van betaling binne 30 (dertig) dae of gewaarborg deur 'n goedgekeurde Bank- en/of Bougenootskapwaarborg.

2. *Voorwaardes:*

Die volle Voorwaardes van Verkoping wat deur die Bode van die Hof onmiddellik voor die verkoping uitgelees sal word, lê ter insae by die Kantoor van die Geregsbode, Alberton.

Gedatceer te Alberton hierdie 11de dag van Mei 1984.

Klopper, Jonker & Vennote, Eiser se Prokureurs, Prudentialgebou, Voortrekkerweg, New Redruth, Alberton.

Case 218/1983

IN THE MAGISTRATE'S COURT FOR THE DISTRICT OF BOKSBURG HELD AT BOKSBURG

In the matter between **Santambank Limited**, t/a Santambank Card, Plaintiff/Execution Creditor, and **Louis Erasmus**, Defendant/Execution Debtor

Be please to take notice that a sale in execution in the above matter will take place on the 6th July 1984 at 11.15 a.m., at the main entrance Magistrate's Court, Adderley Street, Boksburg, which sale will be held by the Messenger of the Court, Boksburg, of the following immovable property:

Erf 772, Van Dykpark Township, Registration Division I.R., Transvaal, situate at 19 Kiepersol Street, Van Dykpark, Boksburg, measuring 763 square metres, comprising a dwelling-house with the usual outbuildings.

Terms:

1. 10 % (ten per centum) of the purchase price shall be paid at the time of the sale in cash or by way of bank guaranteed cheque to the Messenger of the Court, Boksburg;

2. The balance of the full purchase price, together with interest thereon at current rates charged by the United Building Society on similar amounts on first mortgage loans, which said interest shall run from the date of sale to date of registration of transfer, both dates inclusive, for which amount and interest the purchaser shall furnish the Plaintiff's conveyancers, within 31 (thirty-one) days of the date of sale, with a suitable bank or building society guarantee(s), drawn in favour of the Plaintiff and/or the Plaintiff's nominees, subject to the provision that if the Plaintiff be the purchaser, then no deposit or guarantee will be necessary and the Plaintiff shall pay the full purchase price plus interest to the Messenger of the Court in cash against transfer.

Dated at Boksburg on the 18th day of May 1984.

Manfred Jacobs & Husted, Plaintiff's Attorneys, First Floor, Nedbank Centre, Market Street, P.O. Box 331, Boksburg.

Cases 1473/81 and 4143/84

In the matter between **The Bank of Lisbon and South Africa Limited**, Plaintiff, and **John Augustine Pereira**, Defendant

In execution of a judgment of the Supreme Court of South Africa (Witwatersrand Local Division), in the above-mentioned suit, a sale with a Reserve price of R475,16 will be held at the Magistrate's Court Building, 31 President Street, Bothaville, on the 29th June 1984 at 10 o'clock in the forenoon, of the undermentioned property of the Defendant on the conditions to be read out by the Auctioneer at the time of the sale and which Conditions may be inspected at the aforementioned address as well as at the Deputy Sheriff's Enkel Den Building, 13 President Street, Bothaville, prior to the sale:

Certain vacant industrial land being Erf 867, Bothaville Extension 10, measuring 12 619 (twelve thousand six hundred and nineteen) square metres.

The following information is furnished *re* the improvements, though in this respect nothing is guaranteed:

None.

The Sale is subject to the special provisions, privileges and/or exemptions as mentioned in the Certificate of Consolidated Title of the property No. T1810/1977, which document may similarly be inspected at both the aforementioned addresses.

Terms: 10 % of the purchase price and 5 % on the first R10 000,00 and thereafter 2½ % with a maximum of R5 000,00 and a minimum of R30,00 auctioneer's charges in cash on the day of the sale, the balance against transfer to be secured by a Bank or Building Society or other acceptable guarantee to be furnished within 14 days from the date of sale.

Date: 8th May 1984.

C. L. Ziman, for R. F. Katzenellenbogen, Plaintiff's Attorney, Seventh Floor, National Board House, Pritchard Street, P.O. Box 6174, Johannesburg.

Saak 2410/84

IN DIE LANDDROSHOF VIR DIE DISTRIK VAN VEREENIGING GEHOU TE VEREENIGING

Tussen **Barclays National Bank Limited**, Eiser, en **Abraham Johannes Bezuidenhout**, Verweerder

Ten uitvoering van 'n Vonnis van bogemelde Agbare Hof en 'n Lasbrief, gedateer 18de April 1984, sal die volgende eiendom, wat spesiaal beslagbaar verklaar is, in eksekusie verkoop word ten kantore van die Geregsbode, Beaconsfieldlaan 41a, Vereeniging, 1939, om 9.00 vm., op Vrydag, die 22ste dag van Junie 1984, aan die hoogste bieder:

Erf 1716, geleë in die dorpsgebied van Three Rivers Uitbreiding 2, Registrasie Afdeling I Q, Transvaal, groot 1 110 (eenduisend eenhonderd en tien) vierkante meter.

Verkoopsvoorwaardes:

1. Die eiendom sal verkoop word aan die hoogste bieder en die verkoping sal onderworpe wees aan Artikel 66 van die Landdroshowet, No. 32 van 1944.

2. Die Koper sal verantwoordelik wees vir betaling aan die Eiser van rente teen 18 % per jaar op die vonnisskuld vanaf die datum van verkoop tot datum van registrasie van transport.

3. Die koopprys sal as volg betaalbaar wees:

(a) 10 % (tien persent) daarvan onmiddellik na ondertekening van die Verkoopsvoorwaardes; en

(b) die balans van die koopprys binne 14 (veertien) dae, in kontant, of verseker deur 'n bank- of Bougenootskapwaarborg; sodanige betaling en/of waarborg moet verskaf word aan die Geregsbode.

4. Die voorwaardes van verkoop wat uitgelees sal word deur die Geregsbode onmiddellik voor die Geregte Verkoop, sal by sy kantoor ter insae lê.

5. Die eiendom sal verkoop word, onderhewig aan enige bestaande huurkontrak.

Geteken te Vereeniging hierdie 23ste dag van Mei 1984.

L. M. Barnard, vir Snijman Smullen & Theo Rood, Eiser se Prokureurs, Barclays Sentrum, Lesliestraat 29, Posbus 38, Vereeniging.

Case 10101/83

IN THE MAGISTRATE'S COURT FOR THE DISTRICT OF KRUGERSDORP HELD AT KRUGERSDORP

In the matter between **South African Permanent Building Society**, Plaintiff, and **Machiel Frederick Oosthuizen**, Defendant

In pursuance of a Judgment in the Court of the Magistrate of Krugersdorp and Writ of Execution, dated the 25th day of January 1984, the following property will be sold in execution on Wednesday, the 27th day of June 1984 at 10h00, in front of the Magistrate's Court, Biccard Street entrance, Krugersdorp, to the highest bidder, viz:

Erf 330, West Krugersdorp Township, Registration Division I.Q., Transvaal, known as 89 Fisher Street, West Krugersdorp, upon which is erected a single storey dwelling house of brick walls under iron roof, said to contain five rooms, a kitchen and bathroom, and the usual outbuildings in regard to which, however, nothing is guaranteed.

Terms: R1 000,00 cash at the time of the sale and the balance against registration of transfer to be secured by an approved Banker's or Building Society's guarantee to be delivered within 21 days, the purchaser to pay transfer costs, rates, etc. The property will be sold "voetstoots" subject to any tenancy.

The full conditions of sale (which must be signed after the sale) may be inspected during office hours at the office of the Messenger of the Court, 101 President Building, corner of President and Monument Streets, Krugersdorp.

The Plaintiff is prepared to grant a bond to an approved purchaser.

Phillips & Osmond, First Floor, Edanwaves, 1 Monument Street, Krugersdorp.

Case 21467/1983

IN THE SUPREME COURT OF SOUTH AFRICA
(Witwatersrand Local Division)

In the matter between **The Standard Bank of South Africa Limited**, Plaintiff, and **Magdalena Cornelia Catharina Jacobsohn**, Defendant

In execution of a Judgment of the Supreme Court of South Africa, Witwatersrand Local Division, in the above-mentioned suit, a sale with a reserve price, will be held at the Office of the Deputy Sheriff, Room 13, Panorama Building, 55 Charl Cilliers Street, Alberton, on Friday, the 22nd day of June 1984 at 10h00, of the undermentioned unit of the Defendant, on the conditions to be read out by the Deputy Sheriff/Auctioneer at the time of the sale, and which conditions may be inspected at the offices of the Deputy Sheriff, Alberton, prior to the sale consisting of:

(a) Section 9 as shown and more fully described on Sectional Plan No. 26/1977, in the building known as Artis Court, of which the floor area according to the said sectional plan is 102 (one hundred and two) square metres in extent, known as 9 Artis Court, which is situate at 46 Fifth Avenue, Alberton, and;

(b) an undivided share in the common property in the land and building or building as shown and more fully described on the said Sectional Plan, apportioned to the said section, held under certificate of registered Sectional Title No. 26/1977 (9), dated the 18th April 1977;

The unit is a flat and is reported to be comprised of two bedrooms, kitchen, lounge, bathroom with shower and toilet, though in this respect, nothing is guaranteed.

Terms: 10 % (ten per centum) of the purchase price in cash on the day of sale; the balance payable against registration of transfer, to be secured by a Bank, Building Society or other acceptable guarantee to be furnished by the Purchaser within 14 (fourteen) days from the date of sale, Deputy Sheriff's charges, payable by the Purchaser on the day of sale, are payable as follows:

5 % (five per centum) of the purchase price of the property up to an amount of R10 000,00 (ten thousand rand) and thereafter 2½ % (two and a half per centum) up to a maximum of R5 000,00 (five thousand rand). Minimum fees payable in this respect are R20,00 (twenty rand). The Purchaser shall also pay the cost of advertising, and also the costs of the Notices and Conditions of Sale.

Dated at Alberton on this the 21st day of May 1984.

Louis M. Berman, Plaintiff's Attorney, 119 Nevada Centre, Voortrekker Road, New Redruth, P.O. Box 135, Alberton.

Case 4568/78

IN THE MAGISTRATE'S COURT FOR THE DISTRICT OF BRAKPAN HELD AT BRAKPAN

In the matter between **Anglo Carpet (Tvl) (Pty) Limited**, Plaintiff, and **Willem Carel Nel**, Defendant

In pursuance of a Judgment in the Court of the Magistrate of Brakpan, dated the 26th day of October 1978, and the Writ of Execution, dated the 13th day of April 1984, the following will be sold in execution without reserve to the highest bidder on the 6th day of July 1984 at 11h00, at the Magistrate's Court, Offices of the Messenger, Prince George Ave, Brakpan:

Certain Erf 896, Brenthurst Extension 1 Township, Registration Division I.R., Transvaal, measuring 834 (eight hundred and thirty four) square metres, held by the Defendant under Deed Transfer No. T25474/74, dated the 30th December 1974.

Improvements:

Terms and conditions of sale:

1. *Terms:* The Purchase price shall be paid as to 10 per centum (10 %) thereof on the day of the sale and the unpaid balance within fourteen days shall be paid or secured by a Bank or Building Society guarantee.

2. *Conditions:* The full conditions of sale may be inspected in the Messenger's office.

Dated at Brakpan this 18th day of May 1984.

C. M. Janeke, vir Trollop, Joubert, Cowling & Janeke, Attorneys for Plaintiff, 125 a Kingsway Ave, P.O. Box 38, Brakpan.

Case 5705/82

IN THE MAGISTRATE'S COURT FOR THE DISTRICT OF KEMPTON PARK HELD AT KEMPTON PARK

In the matter between **Standard Credit Corporation Limited**, Plaintiff, and **Robert Russell**, Defendant

In pursuance of a judgment of the above Honourable Court and Writ of Execution, the undermentioned property will be sold in execution by the Messenger of the Court, Kempton Park, on Friday, the 12th day of July 1984, at 11h00 in the forenoon in front of the Magistrate's Court, Kempton Park, to the highest bidder:

Certain one half share in the property known as Erf 509, Van Riebeeck Park, situate at 14 Magaliesberg Street, Van Riebeeck Park, measuring 800 (eight hundred) square metres.

The following improvements subsist on the property, but no guarantee thereof is given:

Dwelling house and outbuildings.

Material conditions of sale:

1. The property shall be sold to the highest bidder, without reserve and the sale shall be subject to the provisions of the Magistrate's Court Act, No. 32 of 1944, and amended, and the Rules framed thereunder.

2. The sale will be subject to payment of 10 % of the purchase price on the date of sale, a bank or building society guarantee to be furnished within 14 (fourteen) days of date hereof, securing payment of the balance.

The full conditions of sale which will be read out immediately prior to the sale, may be inspected at the office of the Messenger of the Court, Kempton Park.

Dated at Benoni this 2nd day of May 1984.

H. A. Welgemoed, for Slomowitz Dobie Smith & Myburgh Inc., c/o Botha Massyn & Mac Kenzie, Botha Buildings, 23 Central Avenue, Kempton Park.

Saak 662/83

IN DIE LANDDROSHOF VIR DIE DISTRIK VAN VANDERBIJLPARK GEHOU TE VANDERBIJLPARK

In die saak tussen **S A Permanent Building Society**, Eiser, en **F. A. Skifter-Hansen**, Verweerder

Ten uitvoering van 'n Vonnis van bogemelde Agbare Hof en 'n Lasbrief, gedateer 10 Februarie 1983, sal die volgende eiendom wat spesiaal beslagbaar verklaar is, in eksekusie verkoop word op 13 Julie 1984 om 10h00 voormiddag, voor die Landdroshofkantoor te Vanderbijlpark, aan die hoogste bieder:

Erf 357, situate in the Vanderbijlpark Park South West 5 Extension 1 Township, Registration Division I.Q., Transvaal, measuring 1 070 (one thousand and seventy) square metres.

Verkoopsvoorwaardes:

1. Die eiendom sal verkoop word aan die hoogste bieder en die verkoping sal onderworpe wees aan Artikel 66 van die Landdroshofwet No. 32 van 1944.

2. Die Koper sal verantwoordelik wees vir betaling aan die Eiser van rente teen 15 % per jaar op die vonnisskuld vanaf die datum van verkoop tot datum van registrasie van transport.

3. Die koopprys sal as volg betaalbaar wees:

(a) 10 % (tien persent) daarvan onmiddellik na ondertekening van die verkoopsvoorwaardes; en

(b) die balans van die koopprys binne 14 (veertien) dae, in kontant, of verseker deur 'n bank- of Bougenootskapwaarborg; sodanige betaling en/of waarborg moet verskaf word aan die Geregsbode te Vanderbijlpark.

4. Die voorwaardes van verkoop wat uitgelees sal word deur die Geregsbode onmiddellik voor die Geregte Verkoop, sal by sy kantoor ter insae lê.

5. Die eiendom sal verkoop word onderhewig aan enige bestaande huurkontrak.

Geteken te Vanderbijlpark hierdie 11de dag van Mei 1984.

D. Schoeman, vir Snijman Smullen & Theo Rood, Fam Ealesgebou, Eric Louwstraat, Vanderbijlpark.

Case 2893/1984

IN THE SUPREME COURT OF SOUTH AFRICA
(Transvaal Provincial Division)In the matter between **South African Permanent Building Society**, Plaintiff, and **Alta Rens**, Defendant

Pursuant to a judgment of the above Court and Writ of Execution, dated the 12th day of April 1984, the undermentioned property will be sold in execution at 10 a.m., on Wednesday, the 27th day of June 1984, at the offices of the Deputy Sheriff, Standard General House, 215 Proes Street, Pretoria, to the highest bidder:

Portion 144, of the farm Randjesfontein 405, Registration Division J.R., Transvaal, measuring 2,4541 hectares, held by the Defendant under Deed of Transfer No. 3811/1982, dated 5th February 1982, known as 144 Riboville Road, Randjesfontein, District of Pretoria.

The following improvements are situate on the property, although in this respect nothing is guaranteed:

A dwelling house consisting of two lounges, two bedrooms, bathroom and kitchen. The house is of a very modern design.

The Conditions of Sale, which will be read immediately prior to the sale, are lying for inspection at the offices of the Deputy Sheriff, Standard General House, 215 Proes Street, Pretoria.

Signed at Pretoria, this 17th day of May 1984.

H. P. Jefferys, c/o Findley & Niemeyer, Plaintiff's Attorney, 635 Permanent Building, Paul Kruger Street, Pretoria.

Saak 25167/83

IN DIE HOOGGEREGSHOF VAN SUID-AFRIKA
(Witwatersrandse Plaaslike Afdeling)In die saak tussen **Boland Bank Beperk**, Eiser, en **Bernard Arthur James**, Verweerder

Kragtens 'n bevel van die bogenoemde Agbare Hof, en 'n Lasbrief tot Eksekusie gedateer die 8ste dag van Februarie 1984, sal die ondergelyste eiendom op die 28ste dag van Junie 1984 om 10h00 deur die Adjunk-Balju van Germiston in eksekusie verkoop word:

Een woonhuis met buitegeboue geleë te Gedeelte 1 van Gekonsolideerde Lot 673, Prinrose Dorpsgebied, Primrosestraat 7, Primrose, Germiston, te Revelas Towers 303, Crossstraat, Germiston.

1. Die eiendom sal verkoop word aan die hoogste bieder, sonder voorbehoud, en die verkoping sal onderhewig wees aan die bepalinge van die Hooggereshof Wet, No. 59 van 1959, soos gewysig, en Reëls.

2. Die koopprys sal betaalbaar wees teen 'n deposito van 10 % (tien per sentum) op die datum van verkoping en die uitstaande balans, tesame met rente daarop teen heersende Bougenootskaps-leningkoerse vanaf die datum van verkoping tot datum van betaling daarvan, sal betaal word of gewaarborg word deur middel van 'n Bank- of Bouverenigingswaarborg binne 14 (veertien) dae na datum van verkoping.

3. Die volgende verbeterings is op die eiendom aangebring, hoewel geen waarborg in die verband hiermee gegee word nie:

(a) 'n woonhuis; en

(b) buitegeboue.

Die verkoopsvoorwaardes sal voor die aanvang van die verkoping voorgelees word en sal by die kantoor van die Adjunk-Balju, ter insae lê.

Geteken te Johannesburg hierdie 9de dag van Mei 1984.

Pieters & Vennote, Prokureurs vir Eksekusieskuldeiser, Sesde Verdieping, RSA-sentrum, hoek van Jorissen- en Mellestraat, Braamfontein; Posbus 348, Randburg.

Saak 8315/84

IN DIE LANDDROSHOF VIR DIE DISTRIK VAN VANDERBIJLPARK GEHOU TE VANDERBIJLPARK

In die saak tussen **Natal Bouvereniging (Permanent)**, Eiser, en **Bjarne Nielsen**, Verweerder

Ten uitvoerlegging van die vonnis hierin toegestaan en die daaropvolgende kennisgewing van beslaglegging, gedateer 12 April 1984, sal die onderstaande eiendom verkoop word deur die Geregsbode op die 6de dag van Julie 1984, by die Landdroshofgebou, Vanderbijlpark om 10h00 vm.:

Erf 1155, geleë in die Vanderbijlpark South West 5/2 Township, Registrasie Afdeling I.Q., Transvaal wat 959 (negehonderd nege en vyftig) vierkante meter bestaan.

1. Die verkoping sal onderbewig wees aan die bepalings van die Landdroswet No. 32 van 1944, en die Reëls daaronder uitgevaardig, die voorwaardes bevat in die Akte/s van Transport, en sal verkoop word aan die hoogste bieder onderbewig aan die verkoopsvoorwaardes wat beskikbaar is by die Geregsbode, Vanderbijlpark.
2. Die koper sal aan die Geregsbode 10 % van die koopprys betaal onmiddellik na die ondertekening van die verkoopsvoorwaardes en hom ook voorsien van 'n Bank- of Bouvereniging waarborg binne een-en-twintig (21) dae vanaf die datum van die verkoop vir die balans van die koopprys.
3. Die eksekusieskuldeiser sal die verskaffing van 'n lening tot hoogstens 90 % van die koopprys van die eiendom aan 'n goedgekeurde koper, gunstig oorweeg, en reëlings moet met die Eksekusieskuldeiser getref word voor die verkoping.
4. Die straatadres van die eiendom is Verdijkstraat 28, Vanderbijlpark.
5. Die volledige verkoopsvoorwaardes kan ter insae geneem word by die kantoor van die Geregsbode gedurende kantoorure en sal ook uitgelees word voor die eiendom opgeveil word.

Gedateer te Vanderbijlpark hierdie 17de dag van Mei 1984.

A. F. Barendse, vir Barendse & Botha, Prokureurs vir Eiser, B & W-gebou, Eerste Verdieping, Van Rijnstraat, Vanderbijlpark.

Case 13007/84

IN THE MAGISTRATE'S COURT FOR THE DISTRICT OF PRETORIA HELD AT PRETORIA

In the matter between **United Building Society**, Plaintiff, and **Merwelene Van der Merwe**, Defendant

A sale in execution of the property described hereunder will be held in front of the Magistrate's Court, Pretoria, at 11h00 on 20 June 1984:

- (a) Section 19 as shown and more fully described on Sectional Plan No. 38/1978, in the building or buildings known as Cadrille, of which the floor area, according to the said sectional plan is 76 square metres in extent; and
- (b) an undivided share in the common property in the land and building or buildings as shown and more fully described on the said sectional plan, apportioned to the said section in accordance with the participation quota of the said section, held under Certificate of Registered Sectional Title No. 38/1978 (19) (Unit), dated 11 May 1978.

The following particulars are furnished but not guaranteed:

Known as Unit 19, Cadrille Flats, 281 Jacob Mare Street, Pretoria, this is a neat and well-kept duplex flat situated in a White area in a good position near city centre and next to Melrose House.

Improvements comprise:

1. Brick under concrete flatroofed duplex flat consisting of lounge, diningroom, kitchen, 1½ bedrooms and a bathroom. Construction includes "compo" ceilings, vinyl tile and carpeted floors, built-in cupboards and a hot water system.
2. Carport.

A substantial Building Society bond can be arranged for an approved purchaser.

The conditions of sale may be inspected at the office of the Messenger of the Court (Southern Area), Sentrakor Building, Pretorius Street, Pretoria.

R. du Plessis, c/o MacRobert, De Villiers & Hitge Inc., 501 United Building, 263 Andries Street, Pretoria.

Case 2790/81

IN THE MAGISTRATE'S COURT FOR THE DISTRICT OF WONDERBOOM HELD AT PRETORIA NORTH

In the matter between **United Building Society**, Plaintiff, and **Rymore Boerdery (Edms.) Bpk.**, Defendant

A sale in execution of the property described hereunder will be held in front of the Magistrate's Court, Wonderboom, at 10 a.m., on 22 June 1984:

Holding 13 Rynoue Agricultural Holdings, Registration Division J R, Transvaal, measuring 2,1414 hectare.

The following particulars are furnished but not guaranteed:

Known as 13 Row Street, Rynoue Agricultural Holdings, this plot which is situated in a White area has well developed gardens and a sufficient water supply.

Improvements comprise:

1. Face brick under iron flat roofed dwelling consisting of a lounge, diningroom, kitchen, 3 bedrooms, 2 bathrooms, a study and a laundry. Construction includes compo board and knotty pine ceilings, vinyl tile and carpeted floors, built-in cupboards and a hot water system.

2. Double garage, carport, servant's room and toilet.

A substantial Building Society bond can be arranged for an approved purchaser.

The conditions of sale may be inspected at the office of the Messenger of the Court (Wonderboom), City Hall, Pretoria North.

René du Plessis, c/o MacRobert, De Villiers & Hitge Inc., 501 United Building, 263 Andries Street, Pretoria.

Case 10049/1983

IN THE MAGISTRATE'S COURT FOR THE DISTRICT OF BOKSBURG HELD AT BOKSBURG

In the matter between **Allied Building Society**, Plaintiff, and **Johan Christiaan Kruger**, Defendant

In pursuance of a Judgment in the Court of the Magistrate, Boksburg, dated the 13th day of December 1983, and the Writ of Execution, dated the 23rd day of December 1983, the following will be sold in Execution without reserve to the Highest Bidder, on the 6th day of July 1983, at the Magistrate's Court, Boksburg, at 11.15 a.m.:

Certain Erf 249, Impala Park Township, Registration Division I.R., Transvaal, measuring 892 (eight hundred and ninety-two) square metres, held by the Mortgagor under Deed of Transfer No. T.1472/1976, dated the 20th January 1976.

Improvements:

Single storey residence of brick under iron consisting of five rooms, kitchen and bathroom, carpeted and slasto floors, herculite ceilings.

Outside: Garage, servant's quarters and w.c., situate at 28 Alloutte Street, Impala Park, Boksburg.

Terms and conditions:

1. *Terms:* The purchase price shall be paid as to 10 per centum thereof on the day of the sale and the unpaid balance within (14) fourteen days shall be paid or secured by a Bank or Building Society guarantee.

2. *Conditions of sale:* The full conditions of sale may be inspected in the Messenger's Office.

Dated at Boksburg on this the 29th day of May 1984.

D. G. Tytherleigh, for Trollip, Tytherleigh, 2b Bloem Street, Boksburg.

Saak 273/84

IN DIE LANDDROSHOF VIR DIE DISTRIK VAN SOUTPANSBERG GEHOU TE LOUIS TRICHARDT

In die saak tussen **United Bouvereniging, Eiser, en Johannes Nicolaas Venter, Verweerder**

Kennis word hiermee gegee dat ingevolge 'n uitspraak in die Landdroshof van Soutpansberg gehou te Louis Trichardt in bogenoemde saak op 12 Maart 1984 en ter uitvoering van 'n lasbrief tot uitwinning sal die Geregsbode te Louis Trichardt, op die 15de dag van Junie 1984 om 10h00, voor die Landdroskantore, Munnikstraat, Louis Trichardt, verkoop:

Sekere Erf 2022, Louis Trichardt dorpsgebied, Uitbreiding 2, Registrasie Afdeling LS, Transvaal, groot 1 868 vierkante meter, gehou kragtens Akte van Transport No. 4839/1979, gedateer 23 Februarie 1979.

Bestaande uit een gepleisterde baksteenhuus met sinkdak, motorhuis met afdak, 4 slaapkamers, 2 woonkamers, kombuis/eetkamer, 2 badkamers met ekstra toilet, studeerkamer en toegebooue stoep.

Die Koper moet 'n deposito van 10 % van die koopprys, geregsbode fooi en agterstallige belasting betaal op die dag van die verkoping, die balans betaalbaar teen transport en verseker te word deur 'n waarborg van 'n bank of bouvereniging wat deur die Eiser se prokureur goedgekeur is, die waarborg moet aan die Geregsbode binne 14 dae na datum van die verkoping verstrekk word.

Gemelde Eiendom sal verkoop word op die voorwaardes wat deur die Geregsbode ten tye van die verkoping uitgelees sal word, welke voorwaardes nagegaan kan word by die kantoor van die Geregsbode te Louis Trichardt.

Gedateer te Pretoria op hede die 30ste dag van Mei 1984.

C. G. Stolp, vir Solomon & Nicolson Ing., Eiser se Prokureurs, Tweede Verdieping, N.B.S.-gebou, Pretoriusstraat, Pretoria.

KAAP • CAPE

Case 5441/84

IN THE MAGISTRATE'S COURT FOR THE DISTRICT OF PORT ELIZABETH HELD AT TODD CHAMBERS, TODD STREET, PORT ELIZABETH

Between **Federated Timbers, Execution Creditor, and Gary Lester Felkers, Execution Debtor**

Pursuant to a warrant of execution issued upon a judgment of the above Honourable Court, dated 20th March 1984, a public auction sale in execution of the following immovable property will be held at the front entrance of the New Law Courts, North End, Port Elizabeth, at 2.15 p.m., on Friday, 29th June 1984:

Erf 3036, Gelvandale, in extent 630 square metres, and known as 40 Martin Street, Gelvandale, Port Elizabeth.

It has been reported that the property has been improved by the erection thereon of a brick residence but nothing is guaranteed in this respect.

The material conditions of sale are that the auctioneer's commission and 10 % of the purchase price will be payable on the date of sale, that the sale will be voetstoots and that the proceeds of the sale will be sufficient to satisfy the claim(s) of existing mortgagee(s). The full conditions of sale may be inspected at the office of the Messenger of the Court, Port Elizabeth North.

Dated at Port Elizabeth this 8th May 1984.

Aronson Abramowitz & Company, Execution Creditor's Attorneys, 17th Floor, Brister House, 201 Main Street, Port Elizabeth.

Case 12177/83

IN THE MAGISTRATE'S COURT FOR THE DISTRICT OF BELLVILLE HELD AT BELLVILLE

In the matter between **South African Permanent Building Society, Plaintiff, and Edward Richard Arendse, Defendant**

In the above matter a sale will be held on Wednesday, 27 June 1984 at 12.15 p.m., at the site of 20 Concordia Crescent, Ravensmead, being:

Certain piece of redeemed quitrent land situate in the Municipality of Parow, Cape Division, being Erf 12571, Parow, measuring 287 m².

Conditions of sale:

1. The sale is subject to the terms and conditions of the Magistrate's Court Act, No. 32 of 1944, the property being sold voetstoots and as it stands and subject to the conditions of the existing Title Deed.

2. One-tenth of the purchase price shall be paid immediately after the property is declared to be sold and the balance of the purchase price together with interest thereon at the rate of sixteen comma two five per centum (16,25 %) per annum is to be paid against registration of transfer, which shall be given and taken forthwith after the sale.

3. This property is reserved for the use of members of the Coloured Group.

4. The following improvements are on the property (although nothing in this respect is guaranteed):

A single storey dwelling under an asbestos roof comprising of three rooms, bathroom and single carport.

5. The complete Conditions of Sale will be read out at the time of the sale and may be inspected prior thereto at the offices of the Messenger of the Court, Bellville, and at the offices of the undersigned.

Minde Schapiro & Smith, Attorneys for Plaintiff, 49 Durban Road, Bellville.

Case 8227/83

IN THE MAGISTRATE'S COURT FOR THE DISTRICT OF EAST LONDON HELD AT EAST LONDON

In the matter between **S A Permanent Building Society, Plaintiff, and Joseph Johannes Bezuidenhout, Defendant**

In pursuance of a Judgment of the above Honourable Court and a Writ of Execution, dated 20th March 1984, the following property will be sold on Friday, 22 June 1984 at 10.00 a.m. in the forenoon, in the Main Foyer of the Magistrate's Court, Lower Buffalo Street, East London, to the highest bidder:

Erf 544, East London, Municipality and Division of East London, measuring 2 204 square metres (known as 6 Klein Street, Dawn, East London).

Conditions of sale:

1. The Purchaser shall pay 10 % (ten per centum) of the purchase price on the date of sale and the unpaid balance together with interest is to be secured by a satisfactory Bank or Building Society Guarantee to be furnished to the Plaintiff's Attorneys within 14 (fourteen) days of the sale.

2. The property shall be sold "voetstoots" and shall be subject to the terms and rules of the Magistrate's Court Act and also subject to the provisions of the Title Deed.

3 The full conditions of sale may be inspected at the offices of the Plaintiff's Attorneys and these will be read out by the Auctioneer immediately before the sale.

4. The following information is furnished, but not guaranteed:

The dwelling is of brick plastered construction under a Canadian pattern, asbestos roof, floors to living rooms have wall to wall carpets, with tiles to kitchen and bathroom. There are three bedrooms, lounge/dining room, kitchen and bathroom. The outbuildings which are attached to the dwelling under the main roof, is of similar construction and consists of a single garage and servants room.

Dated at East London this 9th day of May 1984.

Bate Chubb & Dickson Inc., Plaintiff's Attorneys, 42 Terminus Street, East London.

Case 2743/83

IN THE SUPREME COURT OF SOUTH AFRICA
(South Eastern Cape Local Division)

In the matter between **South African Permanent Building Society**, Plaintiff, and **Walter David Doubell**, First Defendant, **Wyndham Slabbert**, Second Defendant

In pursuance of a Judgment of the above Court, dated 22nd November 1983, and an attachment in execution on the 12th December 1983, the following property will be sold in front of the New Law Courts, Main Street, Port Elizabeth, by public auction on Friday, 22nd June 1984, at 2.15 p.m.:

Remainder of Erf 2362, North End in the Municipality of the City of Port Elizabeth, Division of Port Elizabeth, measuring four hundred and ninety five (495) square metres, situate at 62 Middle Street, North End, Port Elizabeth.

While nothing is guaranteed, it is understood that on the property is a single storey, brick dwelling, consisting of four rooms, bathroom, five outside rooms plus toilet.

A substantial Building Society bond can be arranged for an approved purchaser.

The Conditions of Sale will be read immediately prior to the sale and may be inspected at the Deputy Sheriff's Office, Porters Building, 629 Main Street, Port Elizabeth.

Terms: 10 %, and Deputy Sheriff's charges of 5 % on the first R10 000,00 and 2,5 % on the balance, on the date of sale, the balance against transfer to be secured by a Bank or Building Society guarantee, to be approved of by Plaintiff's Attorneys, to be furnished to the Deputy Sheriff within twenty one (21) days from the date of the sale.

Dated at Port Elizabeth this 30th day of April 1984.

Pagden, Christian, Hanley & Parkin, Plaintiff's Attorneys, Permanent Building, 81 Main Street, Port Elizabeth.

Case 774/84

IN THE SUPREME COURT OF SOUTH AFRICA
(South Eastern Cape Local Division)

In the matter between **South African Permanent Building Society**, Plaintiff, and **Eldred Desmond Assumption**, Defendant

In pursuance of a Judgment of the above Court, dated 27th March 1984, and an attachment in execution on the 12th April 1984, the following property will be sold in front of the New Law Courts, Main Street, Port Elizabeth, by public auction on Friday, 29th June 1984 at 2.15 p.m.:

Certain piece of land situate in the Municipality of the City of Port Elizabeth, Division of Port Elizabeth, being Erf 1076, Bethelsdorp, measuring four hundred and seventy six (476) square metres, situate at 15 Blignaut Street, Bethelsdorp, Port Elizabeth.

While nothing is guaranteed, it is understood that on the property is a single storey, detached brick dwelling, consisting of five rooms and bathroom.

A substantial Building Society bond can be arranged for an approved purchaser.

The Conditions of Sale will be read immediately prior to the sale and may be inspected at the Deputy Sheriff's Office, Porters Building, 629 Main Street, Port Elizabeth.

Terms: 10 %, and Deputy Sheriff's charges of 5 % on the first R10 000,00 and 2,5 % on the balance, on the date of sale, the balance against transfer to be secured by a Bank or Building Society guarantee, to be approved of by Plaintiff's Attorneys, to be furnished to the Deputy Sheriff within twenty one (21) days from the date of the sale.

Dated at Port Elizabeth this 1st day of May 1984.

Pagden, Christian, Hanley & Parkin, Plaintiff's Attorneys, Permanent Building, 81 Main Street, Port Elizabeth.

Case 629/83

IN THE SUPREME COURT OF SOUTH AFRICA
(South Eastern Cape Local Division)

In the matter between **Alert Construction**, Plaintiff, and **Sybrand Janse van Vuuren**, Defendant

In pursuance of a judgment of the above Honourable Court, dated 29 March 1983, and a Warrant of Execution, against immovable property issued pursuant thereto, the undermentioned property will be sold in execution on the 22nd day of June 1984, at 14h15 at the front entrance New Law Courts, North End, Port Elizabeth:

1. Certain piece of land situate in the Division of Port Elizabeth, being Erf 2071, Westering, measuring 2 714 square metres, held under Deed of Transfer No. T. 7462/1980.

Nothing in regard to the properties or any buildings which may be erected thereon is guaranteed:

The conditions of sale subject to which the property will be sold will lie for inspection at the offices of the Deputy Sheriff at Porter's Building, 629 Main Street, North End, Port Elizabeth, from the date of publication of this notice.

Dated at Port Elizabeth on this 9th day of May 1984.

Goldberg & De Villiers, Plaintiff's Attorneys, 11th Floor, Santam Building, 140 Main Street, Port Elizabeth.

Case 5585/83

IN THE MAGISTRATE'S COURT FOR THE DISTRICT OF WYNBERG HELD AT WYNBERG

In the matter between S A Permanent Building Society, Judgment Creditor, and Gamat Salle Adams, Judgment Debtor

In execution of the Judgment of the Magistrate's Court of Wynberg in the above matter, a sale will be held on Wednesday, the 27th June 1984, at 12.00 noon, of the following immovable property:

Certain piece of land situate in the Local Area of Grassy Park, Cape Division, being the Remainder of Erf 1689, Grassy Park, measuring three thousand and seventy-three (3 073) square metres, held by the Defendant by Deed of Transfer No. 8657, dated the 10th May 1966, also known as corner of Rooikrans Avenue and First Road, Grassy Park, and comprising a detached single-storey house of brick construction enclosed with a Vibacrete Wall. It has 4 rooms and bathroom, wood strip floors, asbestos roof with a brick/asbestos servant's room, storeroom and toilet. Municipality supplies, water, electricity and sanitation.

Conditions of sale:

1. The sale is subject to the terms and conditions of the Magistrate's Court Act, No. 32 of 1944, the property being sold voetstoots and as it stands and subject to the conditions of the existing title deed. The highest bidder shall be the purchaser, subject to the provisions of section 66 of the above Act.

2. One-tenth ($\frac{1}{10}$ th) of the purchase price shall be paid in cash or by means of a bank-marked cheque and immediately after the property is declared to be sold to the balance of the purchase price together with interest thereon at the ruling building society rate to be paid against registration of transfer, and received within fourteen (14) days after the date of sale by a bank or building society guarantee.

3. Attention is drawn to the provisions of the Group Areas Act, No. 36 of 1966, as amended, and also the Community Development Act, No. 3 of 1966, as amended, and the onus shall be on the purchaser to obtain the necessary proof or permit enabling such purchaser to acquire the property, within fourteen (14) days of the date of sale.

And subject to further conditions which will be read out at the time of the sale and which may be inspected at the offices of the Messenger of the Court at Wynberg, and at the offices of the undermentioned Auctioneers:

Jacobs Trust, 601 Heerengracht Centre, Foreshore, 8001.

Herold Gie & Groadhead, Attorneys for Judgment Creditor, 8 Darling Street, Cape Town.

Case 8021/83

IN THE MAGISTRATE'S COURT FOR THE DISTRICT OF BELLVILLE HELD AT BELLVILLE

In the matter between Standard Building Society, Plaintiff, and Christie Johannes Saulse, Defendant

In pursuance of a Judgment in the Court of the Magistrate of Bellville, and Writ of Execution, dated 11th November 1983, the following will be sold in Execution on 20th June 1984 at 11 a.m., at 303 Eighth Avenue, Kraaifontein, to the highest bidder, the property being more fully described as:

Erf 5833, a Portion of Erf 3618, Kraaifontein, situate in the Municipality of Kraaifontein, Division of Paarl, in extent four hundred and ninety-six (496) square metres, also known as 303 Eighth Avenue, Kraaifontein.

Conditions of sale:

1. The property shall be sold without reserve and to the highest bidder and shall be subject to the terms and conditions of the Magistrate's Court Act and the Rules thereunder and of the Title Deeds in so far as these are applicable.

2. The following improvements on the property are reported but nothing is guaranteed:

A single-storey dwelling with brick walls under Canadian pattern asbestos consisting of a lounge, dining room, kitchen, 3 bedrooms, bathroom, separate toilet and a patio.

3. *Terms:* The purchase price shall be paid as to ten per cent thereof in cash upon signature of the Conditions of Sale, or otherwise as the Auctioneer or Messenger of the Court may arrange, and the unpaid balance together with interest thereon at the rate of 16,25 % per annum to date of registration of transfer, against registration of transfer, which amount is to be secured by approved banker's or Building Society guarantee to be delivered within 14 (fourteen) days of the sale.

4. *Conditions:* The full Conditions of Sale which will be read out by the Messenger of the Court, Bellville, immediately prior to the sale may be inspected in his office.

Tennant & Company, 86 St. George's Street, Cape Town.

Case 272/84

IN THE MAGISTRATE'S COURT FOR THE DISTRICT OF THE CAPE HELD AT CAPE TOWN

In the matter between S A Permanent Building Society, Judgment Creditor, and Leonard Phillips, Judgment Debtor

In execution of the Judgment of the Magistrate's Court of Cape Town in the above matter, a sale will be held on Thursday, the 28th June 1984 at 10.00 a.m., at the property of the following immovable property:

Certain Erf 112638, portion of Erf 115678, Cape Town at Salt River, situate in the City of Cape Town, Cape Division, measuring one hundred and seventeen (117) square metres, held by the Defendant by Deed of Transfer No. T 46918/1982, dated the 9th December 1984, also known as 22 Dave Street, Salt River, and comprising a single storey semi-detached dwelling of brick construction with 3 rooms and bathroom and an iron roof and enclosed with a wall. Services include electricity, water and sanitation which is supplied by the Municipality.

Conditions of sale:

1. The sale is subject to the terms and conditions of the Magistrate's Court Act, No. 32 of 1944, the property being sold voetstoots and as it stands and subject to the conditions of the existing title deed. The highest bidder shall be the purchaser, subject to the provisions of section 66 of the above Act.

2. One-tenth ($\frac{1}{10}$ th) of the purchase price shall be paid in cash or by means of a bank-marked cheque and immediately after the property is declared to be sold and the balance of the purchase price together with interest thereon at the ruling building society rate to be paid against registration of transfer, and received within fourteen (14) days after the date of sale by a bank or building society guarantee.

3. Attention is drawn to the provisions of the Group Areas Act, No. 36 of 1966, as amended, and also the Community Development Act, No. 3 of 1966, as amended, and the onus shall be on the purchaser to obtain the necessary proof or permit enabling such purchaser to acquire the property, within fourteen (14) days of the date of sale.

And subject to further conditions which will be read out at the time of the sale and which may be inspected at the offices of the Messenger of the Court at Cape Town, and at the offices of the undermentioned Auctioneers:

J. J. Hofmeyr & Son, 117 St George's Street, Cape Town.

Herold Gie & Broadhead, Attorneys for Judgment Creditor, 8 Darling Street, Cape Town.

**IN DIE HOOGGEREGSHOF VAN SUID-AFRIKA
(Noord-Kaapse Afdeling)**

In die saak tussen **Die Standard Bank van Suid-Afrika Beperk, Eiser, en Johannes Harms Basson, Verweerder**

Ter uitwinning van 'n Vonnis van die Hooggeregshof van Suid-Afrika (Noord-Kaapse Afdeling), gedateer 28 Oktober 1983 in bogemelde saak, en Lasbrief tot Beslaglegging—Onroerende Goed—uitgereik op 30 Maart 1984, sal 'n verkoping per openbare veiling gehou word deur die Adjunk-Balju van Gordonia voor die Landdroshof kantore te Kakamas, Kaapprovinsie, op die 22ste dag van Junie 1984 om 10h00, van die ondergemelde eiendom van die Verweerder op die voorwaardes wat ter insae lê by die kantore van die Adjunk-Balju, en wat deur hom gelees sal word voor die verkoping:

Sekere grond geleë in die Afdeling van Kenhardt synde die restant van Gedeelte 1 (Bynabo) van die plaas Narries 7, groot as sulks twee-en-sestig komma twee nul twee vier (62,2024) hektaar, gehou deur Johannes Harms Basson, kragtens Akte van Transport No. T. 1991, gedateer 1 Februarie 1980.

Terme:

10 % (tien persent) van die koopprys in kontant en die afslaer se gelde in kontant op die dag van die verkoping en die balans teen transport, verseker te word deur 'n goedgekeurde bank- of bouverenigingwaarborg binne veertien (14) dae vanaf datum van verkoping verskaf te word.

Gedateer te Kimberley, op hede die 15de dag van Mei 1984.

G. N. M. Croft & Kie., Permanentegou 218, Jonesstraat, Posbus 378, Kimberley.

Saak 37/84

**IN DIE LANDDROSDISTRIK PRINS ALBERT GEHOU TE PRINS ALBERT
In die saak tussen **Munisipaliteit Prins Albert, Eiser, en G. Delpont, Verweerder****

Geliewe kennis te neem dat die vaste eiendom van bogemelde Verweerder geleë te Enslinstraat, langs Van der Rosskafee, Prins Albert, synde Erf 758, groot 397 vierkante meter, per openbare veiling deur die Geregsbode, Prins Albert om 10.00 v.m., op Vrydag, 15 Junie 1984 te Erf 758, Enslinstraat, Prins Albert, verkoop sal word, teen die hoogste bod, onderhewig egter aan die verbandvoorwaardes en algemene verkoopvoorwaardes soos beskikbaar by die Afslaer.

Geteken te Prins Albert op hede die 18de dag van Mei 1984.

Markotter & Van der Walt, Eiser se Prokureurs, Kerkstraat 37, Posbus 11, Prins Albert, 6930.

Saak 35/84

**IN DIE LANDDROSDISTRIK PRINS ALBERT GEHOU TE PRINS ALBERT
In die saak tussen **Munisipaliteit Prins Albert, Eiser, en S. Delpont, Verweerder****

Geliewe kennis te neem dat die vaste eiendom van bogemelde Verweerder geleë te Enslinstraat, tussen Van der Rosskafee en die kliniek, Prins Albert, synde Erf 759, groot 397 vierkante meter, per openbare veiling deur die Geregsbode, Prins Albert om 10.00 v.m., op Vrydag, 15 Junie 1984 te Erf 759, Enslinstraat, Prins Albert, verkoop sal word, teen die hoogste bod, onderhewig egter aan die verbandvoorwaardes en algemene verkoopvoorwaardes soos beskikbaar by die Afslaer.

Geteken te Prins Albert op hede die 18de dag van Mei 1984.

Markotter & Van der Walt, Eiser se Prokureurs, Kerkstraat 37, Posbus 11, Prins Albert, 6930.

Case 029588/82

IN THE MAGISTRATE'S COURT FOR THE DISTRICT OF WYNBERG HELD AT WYNBERG

In the matter between **Draughtsman Services, Plaintiff, and D. Hendricks, Defendant**

Be pleased to take notice that pursuant to a judgment, the undermentioned immovable property will be sold in execution at the site i.e. 209 Fourth Avenue, Grassy Park, on 29th June 1984 at 12 noon:

Certain piece of land situate in the Local area of Grassy Park, Cape Division, being Erf 6177, a portion of Erf 623, Grassy Park, at Grassy Park, measuring five hundred and eighteen (518) square metres.

The property is suitable for buyers of the Coloured group and is subject to the following conditions:

The property will be sold to the highest bidder, voetstoots and without warranty of possession, the price being payable either in cash on sale or as to ten per cent (10 %) of the price in cash on sale and the balance against transfer plus interest on any unpaid balance at the rate of twelve per cent (12 %) per annum from date of sale, such balance to be secured by an approved guarantee for payment thereof within six (6) weeks of sale.

The buyer shall—

- (a) pay Auctioneers charges, costs of advertising and all other costs, charges and arrear rates, if any, necessary to enable transfer to be given;
- (b) obtain within six (6) weeks of sale, if necessary a permit under the Group Areas Act and a Certificate under the Group Areas Development Act;
- (c) insure the property against damage by fire;
- (d) be liable on cancellation in case of default for damages including wasted costs.

The full conditions of sale will be announced at the sale and may be inspected at the offices of the Messenger of the said Court or at the offices of the Auctioneers.

Dated at Cape Town this day of May 1984.

Gelb Gelb Simon & Shapiro, Plaintiff's Attorneys, French Bank Building, 4 Church Square, Cape Town.

Case 38/83

IN THE MAGISTRATE'S COURT FOR THE DISTRICT OF PIKETBERG HELD AT PIKETBERG

In the matter between **The South African Permanent Building Society, Judgement Creditor, and Desmond Andrew van Wyk, Judgement Debtor**

In execution of the Judgement of the Magistrate's Court of in the above matter, on the 22nd June 1984 at 11.00 a.m., at 1 Loop Street, Piketberg, a sale of the following immovable property, situate at the said address, namely:

Erf 1064, Piketberg, situate in the Municipality of Piketberg, Administrative District of Swartland, Mootreesburg, in extent one thousand and eighty (1 080) square metres.

The property includes a dwelling comprising single dwelling with 4 rooms, bathroom of brick construction garage.

Conditions of sale:

1. The sale is subject to the terms and conditions of the Magistrate's Court Act No. 32 of 1944 (as amended), the property being sold "voetstoots" and as it stands and subject to the conditions of the existing Title Deed. The highest bidder shall be the Purchaser, subject to the provisions of Section 66 of the above Act.

2. One tenth ($\frac{1}{10}$ th) of the purchase price shall be paid in cash or by means of a bank-marked cheque immediately after the property is declared to be sold and the balance of the purchase price, together with interest thereon at the ruling Building Society rate to be paid against registration of transfer, and secured within fourteen (14) days after the date of sale by a Bank or Building Society guarantee.

3. Attention is drawn to the provisions of the Group Areas Act, No. 36 of 1966, and also Act No. 3 of 1966. The property is situate within a proclaimed Coloured Group Area.

And subject to further conditions which may be read out at the time of the sale and which may be inspected at the offices of the Messenger of the Court, Piketberg, and at the offices of the Auctioneers, Messrs. Ford & Van Nierkerk, 156 Main Road, Plumstead.

Pincus Matz & Feinberg, Attorneys for Judgement Creditor, 66 Main Road, Claremont.

Case 2905/84

IN THE MAGISTRATE'S COURT FOR THE DISTRICT OF GOODWOOD HELD AT GOODWOOD

In the matter between **Lulenco Plant Hire (Pty) Ltd**, Plaintiff, and **H. L. van der Westhuizen**, Defendant

In execution of the Judgment of the Magistrate's Court of Goodwood in the above matter, a Sale will be held at 11 a.m., on 4th day of July 1984, on the spot, of the following immovable property:

Certain Erf 2719, situate in the Municipality of Pinelands, Cape Division, measuring 872 square metres, held under Deed of Transfer No. 10784/83, also known as 29 Daffodil Way, Pinelands, with buildings and erections thereon.

Conditions of sale:

1. The sale is subject to the terms and conditions of the Magistrate's Court Act, No. 32 of 1944 (as amended), the property being sold voetstoots and as it stands and subject to the conditions of the existing Title Deed. The highest bidder shall be the purchaser, subject to the provisions of Section 66 of the above Act.

2. One-tenth ($\frac{1}{10}$ th) of the purchase price shall be paid in cash or means of a bank-marked cheque immediately after the property is declared to be sold and the balance of the purchase price, together with interest thereon at the ruling Building Society rate to be paid against registration of transfer, and secured within fourteen (14) days after date of sale by a Bank or Building Society guarantee.

3. Attention is drawn to the provisions of the Group Areas Act, No. 36 of 1966, and also Act No. 3 of 1966. The property is situated with a proclaimed White Group Area.

And subject to the further conditions which may be read out at the time of the Sale and which may be inspected at the Offices of the Messenger of the Court, Goodwood, and at Claremart Auctioneers, 146 Victoria Street, Woodstock.

Dated at Cape Town this 21st day of May 1984.

Arthur E. Ebrahams & Gross, Plaintiff's Attorneys, Fifth Floor, Green Market Place, 54 Shortmarket Street, Cape Town.

Saak 852/83

IN DIE HOOGGEREGSHOF VAN SUID-AFRIKA

(Noord-Kaapse Afdeling)

In die saak tussen **De Boeren Ko-Op Molen Maatschappij Beperkt**, Eiser, en **D. J. Engelbrecht**, (handelend as Oases Kafce), Verweerder

Ingevolge 'n uitspraak van bogenoemde Hof en Laasbrief tot Eksekusie, gedateer 22 November 1983, sal die hierondervermelde eiendom geregtelik verkoop word op Vrydag, 6 Julie 1984 om 11h00, te die kantore van die Adjunk-Balju, Victoria-Wes, met 'n reserweprys van R14 322,05:

Eiendomsgrond geleë in die Munisipale gebied en afdeling van Victoria-Wes, Erf 822, Victoria-Wes, groot 1 274 vierkante meter, gehou kragtens Akte van Transport T51173/81, gedateer 17 November 1981, geleë te Landboustraat 1, Victoria-Wes.

'n Aansienlike Bouverenigingverband kan gereël word vir 'n goedgekeurde koper.

Die verkoopsvoorwaardes wat onmiddellik voor die verkoping gelees sal word, lê ter insae te die kantoor van die Adjunk-Balju, Kerkstraat 84, Victoria-Wes. Die gesegde verkoopsvoorwaardes bevat onder andere die volgende voorwaardes:

(a) Die koper moet 'n deposito van tien persent van die koopprys kontant op die dag van die verkoping betaal, die balans betaalbaar teen transport en verserke te word deur 'n waarborg van 'n Bank- of Bougenootskap wat deur die Eiser se prokureurs goedgekeur is, die waarborg aan die Adjunk-Balju binne 14 dae na die datum van die verkoping verstrek te word;

(b) Die Koper moet afslaersgelde op die dag van die verkoping betaal.

Kallie Engelbrecht, vir MacRobert, De Villiers & Hitge Inc., Unitedgebou 501, Andriesstraat 263, Pretoria.

NATAL

Case 978/84

IN THE MAGISTRATE'S COURT FOR THE DISTRICT OF DURBAN HELD AT DURBAN

In the matter between **South African Permanent Building Society**, Execution Creditor, and **Pirithpal**, Execution Debtor

In pursuance of a Judgment in the Court of the Magistrate of Durban, dated 10th February 1984 and a Writ of Execution issued thereafter, the immovable property listed hereunder will be sold in execution on the 5th day of July 1984, at 10h00, in front of the Magistrate's Court, Durban, to the highest bidder:

Subdivision 1 of E of Lot J3 of the farm Brickfield 806, situate in the City and County of Durban, Province of Natal, in extent four hundred and sixty four (464) square metres. Group Area Indian.

Postal address:

60 Mallinson Road, Sydenham, Durban.

Improvements: (but nothing is guaranteed in respect thereof):

Brick dwelling under Asbestos Roof comprising of 2 bedrooms, lounge, kitchen, bathroom, toilet and verandah. Zoned Special Residential.

1. The sale shall be subject to the Magistrate's Court Act, No. 32 of 1977 (as amended) and the Rules made thereunder.

2. No bid will be accepted by or on behalf of a person who is not a member of the Indian Group and the purchaser (other than the Execution Creditor) shall pay a deposit of 10 % of the purchase price or R500,00 whichever is the greater, in cash at the time of the sale.

3. The balance of the purchase price is payable against transfer to be secured by a Bank or Building Society guarantee approved by the Execution Creditor's attorneys and to be furnished within fourteen (14) days after the date of the sale.

4. The Purchaser shall be liable for the payment of interest at the rate of 19.75 % per annum to the Execution Creditor from date of sale to date of registration of transfer.

5. Transfer shall be effected by the Attorneys for the Execution Creditor and the purchaser shall pay all transfer costs including arrear and current rates, sewerage connection fees (if any), taxes and other charges necessary to effect transfer on request by the said Attorneys.

6. The full conditions of sale may be inspected at the offices of the Messenger of the Court, 1st Floor, 17/19 Mona Road, Durban, and interested parties are asked to contact the Execution Creditor who may be prepared to grant loan facilities to an approved purchaser.

Dated at Durban this 11th day of May 1984.

Clemmans & Johnston Incorporated, Execution Creditor's Attorneys, Suite 201 Permanent Building, 343 Smith Street, Durban.

Case 3718/83

IN THE MAGISTRATE'S COURT FOR THE DISTRICT OF LOWER TUGELA HELD AT STANGER

In the matter between **Inderpal R. Ramdhane**, Execution Creditor, and **Badreepersad**, Execution Debtor

In pursuance of a Judgment granted on the 6th March 1984, in the Magistrate's Court, at Stanger, and under a Writ of Execution issued thereafter, the immovable property listed under will be sold in execution on Friday, the 29th day of June 1984 at 10.00 a.m., at the front entrance to the Magistrate's Court Building, Stanger, to the highest bidder according to the conditions of Sale which will be read out by the Messenger of the Court, Stanger, at the time of the sale:

A $\frac{9}{10}$ th share in and to Sub 19 (of 13) of Lot 34, No. 2616, situate in the County of Victoria, Province of Natal, in extent 2,0234 hectares, including the sugar cane quota attaching thereto.

Residential address:

Near Singpat's Garage, Nonoti, Lower Tugela District.

Improvements:

Brick and tile dwelling with 3 bedrooms, lounge cum dining room, kitchen, bathroom, prayer room, scullery, toilet, single garage adjoining main building.

Material conditions:

1. The Sale shall be subject to the terms and conditions of the Magistrate's Court Act and the Rules made thereunder.
2. The Property shall be sold to the Highest Bidder at the Sale.
3. The Purchaser shall pay 10 % of the purchase price immediately the sale is concluded, and the balance upon transfer of the Property into his name, to be secured by a Bank or Building Society guarantee delivered to the Messenger of the Court within seven (7) days of the date of Sale.
4. The attention of all prospective purchasers is directed to the provisions of the Group Areas Act. The property is owned by a member of the Indian Group.
5. Should the Purchaser fail to carry out any of the Conditions of Sale, the 10 % deposit referred to above will be forfeited. The full conditions may be inspected at the offices of the Messenger of the Court, 22 Jackson Street, Stanger, Natal, in the Lower Tugela District.

Dated at Stanger, this 11th day of May 1984.

Laurie C. Smith, de Broglio Inc., 22 Jackson Street, P.O. Box 46, Stanger.

Case 136/84

IN THE MAGISTRATE'S COURT FOR THE DISTRICT OF LOWER TUGELA HELD AT STANGER

In the matter between **Mrs D. L. King**, **Giyanswar Sing**, **Mrs Sivltri**, **Miss I. K. Bodasing**, **Lower Tugela Investments (Pty) Ltd**, and **Father J. Stevens**, Execution Creditors, and **Basgor Singh A. K. A. Sunny Singh**, Execution Debtor

In pursuance of a Judgment granted on the 19th March 1984 in the Magistrate's Court, at Stanger, and under a Writ of Execution issued thereafter, the immovable properties, listed under will be sold in execution on Friday, the 29th day of June 1984 at 10.00 a.m., at the front entrance to the Magistrate's Court Building, Stanger, to the highest bidder according to the conditions of Sale which will be read out by the Messenger of the Court, Stanger, at the time of the sale:

1. Subdivision 9 of Lot 56, No. 7033, situate in the County of Victoria, Province of Natal, in extent 4,0469 hectares.
2. Subdivision 13 of Lot 56, No. 7033, situate in the County of Victoria, Province of Natal, in extent 16,4770 hectares, together with the sugar cane quotas attaching thereto.

Residential address:

Doornkloof, Upper Tongaat, in the Lower Tugela District.

Improvements:

Both properties are vacant land.

Material conditions:

1. The Sale shall be subject to the terms and conditions of the Magistrate's Court Act and the Rules made thereunder.
2. The Properties shall be sold to the Highest Bidder at the Sale.
3. The Purchaser shall pay 10 % of the purchase price immediately after the sale is concluded, and the balance upon transfer of the properties into his name, to be secured by a Bank or Building Society guarantee delivered to the Messenger of the Court within seven (7) days of the date of Sale.
4. The attention of all prospective purchasers is directed to the provisions of the Group Areas Act. The Properties are owned by a member of the Indian Group.
5. Should the Purchaser fail to carry out any of the Conditions of Sale, the 10 % deposit referred to above will be forfeited. The full conditions may be inspected at the offices of the Messenger of the Court, 22 Jackson Street, Stanger, Natal, in the Lower Tugela District.

Dated at Stanger, this 11th day of May 1984.

Laurie C. Smith, de Broglio Inc., Execution Creditor's Attorneys, 22 Jackson Street, P.O. Box 46, Stanger.

Case 1877/83

IN THE MAGISTRATE'S COURT FOR THE DISTRICT OF VRYHEID HELD AT VRYHEID

In the matter between **Standard Building Society**, Plaintiff, and **N. B. Albertyn**, Defendant

In pursuance of a Judgment in the Court of the Magistrate, Vryheid, and a Warrant of Execution, dated 21st February 1984, the following property will be sold in execution on the 22nd June 1984, in front of the Magistrate's Court, Vryheid, at 11h00, to the highest bidder:

Sub 6 (of 5) Erf 117, Vryheid, Natal, in extent 250 sq. metres.

Sub 2 of Erf 263, Vryheid, Natal, in extent 1 903 sq. metres.

Conditions of sale:

1. The property shall be sold without reserve and to the highest bidder and shall be subject to the terms and conditions of the Magistrate's Court Act and the Rules made thereunder, and of the title deeds, in so far as these are applicable.

2. The following improvements on the property have been reported, but nothing guaranteed:

A dwelling house with usual outbuildings.

3. *Terms:* The Purchase Price shall be paid as to ten per centum (10 %) thereof on the signing of the Conditions of Sale, and the unpaid balance together with interest thereon at the rate stipulated in the First Mortgage Bond registered against the property to date of payment, within fourteen (14) days, to be paid or secured by an approved Bank or Building Society guarantee.

4. *Conditions:* The full conditions of sale, which will be read by the Messenger of the Court, Vryheid, immediately prior to the sale, may be inspected at his office and at the office of Uys & Partners, First Floor, Minks Building, 129 Landdrost Street, Vryheid.

Dated at Vryheid this 23rd day of May 1984.

Uys & Partners, 129 Landdrost Street, P.O. Box 231, Vryheid, 3100.

Case 4028/83

IN THE MAGISTRATE'S COURT FOR THE DISTRICT OF LADYSMITH HELD AT KLIP RIVER

In the matter between **Blaikie-Johnstone (Ladysmith) (Pty) Ltd**, Plaintiff, and **G. L. Coetzee**, Defendant

In Pursuance of a Judgment granted in the above Honourable Court, dated 19th January 1984, and a Warrant of Execution, the undermentioned property will be sold in execution on Thursday, the 21st day of June 1984 at 09h00, at 5 Poort Road, Ladysmith:

Lot 1957, Ladysmith Township, situate in the Borough of Ladysmith, County of Klip River, Province of Natal, in extent one thousand four hundred and seventy nine (1 479) square metres.

Material conditions:

1. The property shall be sold without reserve to the highest bidder subject to the terms and conditions of the Magistrate's Court's Act and the rules made thereunder and the terms and conditions of the Group Areas Act and Group Areas Development Act.

2. The purchaser shall pay 10 % of the purchase price upon conclusion of the sale in cash and shall guarantee the balance within 14 days.

3. The property is deemed to be sold voetstoots.

The full conditions may be inspected at the Offices of the Messenger of the Court, 5 Poort Road, Ladysmith.

Christopher Walton & Tatham, 133 Murchison Street, P.O. Box 126, Ladysmith.

Case 18843/83

IN THE MAGISTRATE'S COURT FOR THE DISTRICT OF DURBAN HELD AT DURBAN

In the matter between **La Marne (Proprietary) Limited**, Plaintiff, and **I. S. Nortje**, Defendant

In pursuance of a Judgment in the Court of the Magistrate of Durban, dated 19th August 1983, and a Writ of Execution, dated 2nd November 1983, the following property will be sold in execution on the 6th day of July 1984 at 10 a.m., at the front entrance to the Magistrate's Court Building, Chancery Lane, Pinetown, to the highest bidder:

Sub 3 of Lot 3520, Pinetown Township, situate in the Borough of Pinetown and in the Pinetown Regional Water Services Area, County of Durban Province of Natal in extent 2 639 square metres.

Street address: 19 Belvedere Road, Cowies Hill, held by the Defendant under Deed of Transfer No. 5833/1970, dated 22nd April 1970.

Postal address: Main brick under tile dwelling consisting of 4 bedrooms, en suite, study room, large lounge and diningroom, bathroom, toilet (separate), kitchen and verandah.

Outbuildings:

Ironing room, large bedroom, servants quarters, toilet, double garage, swimming pool, crazy paving all around house and swimming pool.

Nothing is guaranteed in these respects.

1. The property shall be sold without reserve and to the highest bidder and shall be subject to the terms and conditions of the Magistrate's Courts Act and the Rules made thereunder and of the Title Deeds, insofar as these are applicable.

2. The purchaser shall pay ten per centum (10 %) of the purchase price in cash together with the selling commission immediately after the sale and the balance shall be paid or secured by a satisfactory Bank or Building Society guarantee, to be approved by the Plaintiff's Attorneys, to be furnished to the Court Messenger, Pinetown, within fourteen (14) days of the date of sale.

3. Attention of the prospective purchasers is directed to the provisions of the Group Areas Act.

4. Transfer shall be effected by the Attorneys for the Plaintiff and the purchaser shall pay all transfer dues, including transfer duty, current rates, taxes and other charges necessary to effect transfer upon request by the said Attorneys.

The full conditions of sale may be inspected at the office of the Messenger of the Court.

Dated at Durban this 15th day of May 1984.

Berkowitz Kinkel Cohen Inc., Plaintiff's Attorneys, 15th Floor, Durban Bay House, 333 Smith Street, Durban.

IN THE MAGISTRATE'S COURT FOR THE DISTRICT OF DURBAN HELD AT DURBAN

Between **Allied Building Society**, Plaintiff, and **Soooramoney Govender**, Defendant

In pursuance of a Judgment granted on the 30th day of January 1984 in the Court of the Magistrate, Durban, and under a Writ of Execution issued thereafter, the immovable property listed hereunder shall be sold in execution to the highest bidder on the 19th day of June 1984 at 10.00 a.m., in front of the Magistrate's Court, Chatsworth:

Lot 793, Umhlatuzana Township, situate in the City and County of Durban, Province of Natal, in extent 2 925 square metres.

Postal address: 58 31st Avenue, Umhlatuzana Township, Durban.

The property is a vacant piece of land is subject to Expropriation No. 993/1976 and Expropriation No. 422/1980, in respect of a five metre wide tunnel servitude in favour of the City Council of the City of Durban.

1. The sale shall be subject to the terms and conditions of the Magistrate's Court Act and the Rules made thereunder;
2. (a) The Purchaser shall pay a deposit of 10 % of the purchase price and the auctioneer's commission in cash immediately after the sale and the balance against transfer to be secured by a Bank or Building Society Guarantee to be furnished to the Messenger of the Court within fourteen days after the sale, to be approved by the Plaintiff's attorneys;
(b) The Purchaser shall be liable for payment of interest to the Plaintiff at the rate of 16,25 % per annum to the Plaintiff on the respective amount of the award in the Plan of Distribution from the date of sale to date of transfer;
3. Inasmuch as the Defendant is a member of the Indian Group, no bids will be accepted by or on behalf of a person who is not a member of such Group, unless such person exhibits to the auctioneer at the sale, a permit from the Minister concerned authorising him to acquire such property which is in a proclaimed Indian Area.
4. Transfer shall be effected by the attorneys for the Plaintiff and the Purchaser shall pay all transfer dues, including transfer duty, current rates and other necessary charges to effect transfer upon request by the said attorneys.

The full Conditions of Sale may be inspected at the offices of the Messenger of the Court, Chatsworth, 12 Oak Avenue, Kharwastan, Chatsworth, Durban.

Dated at Durban, this 7th day of May 1984.

Romer Robinson & Catterall, Plaintiff's Attorneys, Seventh Floor, Allied Building, Gardiner Street, Durban.

Case 6936/83

IN THE MAGISTRATE'S COURT FOR THE DISTRICT OF PINETOWN HELD AT PINETOWN

In the matter between **The Nasster Ebrahim Trust**, Execution Creditor, and **Roopram**, Execution Debtor

In pursuance of a judgment in the Court of the Magistrate of Pinetown and writ of execution, dated the 10th February 1984 and writ of execution re-issued, dated 23rd March 1984, the immovable property listed hereunder will be sold in execution on the 24th July 1984, at the front entrance to the Magistrate's Court Building, Chatsworth, at 10 a.m., to the highest bidder:

Sub 152 (of 143) of the farm Chat Nine in the City and County of Durban in extent 218 square metres.

Improvements: Semi detached block under asbestos roof dwelling comprising of 2 bedrooms, lounge, kitchen, toilet and bathroom.

Postal address: House 51, Road 502, Chatsworth, 4092.

Material conditions:

1. The sale shall be subject to the terms and conditions of the Magistrate's Act and the rules made thereunder.
2. The purchaser shall pay 10 % of the purchase price immediately after the sale and within fourteen days supply the Messenger of the Court with a Bank or Building Society guarantee for the balance of the purchase price in terms acceptable to the Messenger of the Court.
3. The attention of the prospective purchasers is directed to the provisions of the Group Areas Act.
4. The full provisions may be inspected at our offices and/or at the offices of the Court Messenger, Pinetown.

Dated at Pinetown this 21st day of May 1984.

MacRae Bath & Partners, Plaintiff's Attorneys, 101 Wearcheck House, 16 School Road, Pinetown.

Case 7236/83

IN THE MAGISTRATE'S COURT FOR THE DISTRICT OF PINETOWN HELD AT PINETOWN

In the matter between **United Building Society**, Plaintiff, and **Johannes Jonathan Viljoen**, Defendant

In pursuance of a Judgment granted on the 17th of January 1984, in the Court of the Magistrate, Pinetown, and under a Writ of Execution issued thereafter, the immovable property listed hereunder will be sold in execution on the 22nd of June 1984 at 10.00 a.m., in front of the Magistrate's Court, Pinetown, to the highest bidder:

A certain piece of land being Sub 3 of Lot 338, Berkshire Downs Township, situate in the Borough of New Germany, and in the Pinetown Regional Water Services Area, County of Durban, Province of Natal, in extent two thousand three hundred and twelve (2 312) square metres.

Postal address: 9 Bradfield Place, Berkshire Downs, Pinetown.

Improvements: Brick under tile dwelling consisting of 3 bedrooms, en suite, lounge, diningroom, toilet and bathroom, passage way, double garage with room, toilet and shower and patio.

Town planning: Zoning: Special residential.

Special privileges: Nil.

Group areas act: Group entitled to occupy: White.

Nothing is guaranteed in these respects.

Material conditions:

1. The sale shall be subject to the terms and conditions of the Magistrate's Court Act and the Rules made thereunder.
2. The purchaser shall pay a deposit of 10 % of the purchase price in cash at the time of the sale, the balance against transfer to be secured by a Bank or Building Society Guarantee to be approved by the Plaintiff's Attorneys to be furnished to the Court Messenger within fourteen (14) days after the date of sale.

3. The attention of all prospective purchasers is directed to the provisions of the Group Areas Act.
 4. If more than one property is to be sold, the properties may be purchased separately, unless this is precluded by the conditions of title or law.
- The full Conditions may be inspected at the offices of the Messenger of the Court, Pinetown, or at our offices.
- C. M. Kenton, for Browne Brodie & Co., Plaintiff's Attorneys, 301 United Building, Crompton Street, Pinetown.

Case 4491/1984

IN THE MAGISTRATE'S COURT FOR THE DISTRICT OF DURBAN HELD AT DURBAN
Between **Allied Building Society**, Plaintiff, and **Cornelius van Rooijn**, Defendant

In pursuance of a Judgment granted on the 1st day of March 1984 in the Court of the Magistrate, Durban, and under a Writ of Execution issued thereafter, the immovable property listed hereunder shall be sold in execution to the highest bidder on the 21st day of June 1984 at 10.00 a.m., in front of the Magistrate's Court, Somerset Road, Durban:

Sub 10 of Lot 1 Umbilo 2558, situate in the City and County of Durban, Province of Natal, in extent 556 square metres.

Postal address: 25 Alpha Road, Umbilo, Durban.

The property consists of a brick under tile roof dwelling, comprising of 3 bedrooms, lounge, kitchen, dining room, separate bathroom and toilet and an outbuilding with 2 servants rooms, toilet and shower;

1. The sale shall be subject to the terms and conditions of the Magistrate's Court Act and the Rules made thereunder;
2. (a) The Purchaser shall pay a deposit of 10 % of the purchase price and the auctioneer's commission in cash immediately after the sale and the balance against transfer to be secured by a Bank or Building Society Guarantee to be furnished to the Messenger of the Court within fourteen days after the sale, to be approved by the Plaintiff's attorneys;
- (b) The Purchaser shall be liable for payment of interest to the Plaintiff at the rate of 16,25 % per annum to the Plaintiff on the respective amount of the award in the Plan of Distribution from the date of sale to date of transfer;
3. Inasmuch as the Defendant is a member of the White Group, no bids will be accepted by or on behalf of a person who is not a member of such Group, unless such person exhibits to the auctioneer at the sale, a permit from the Minister concerned authorising him to acquire such property which is in a proclaimed White Area.
4. Transfer shall be effected by the attorneys for the Plaintiff and the Purchaser shall pay all transfer dues, including transfer duty, current rates and other necessary charges to effect transfer upon request by the said attorneys.

The full Conditions of Sale may be inspected at the offices of the Messenger of the Court, Durban North, First Floor, 17 Mona Road, Durban.

Dated at Durban, this 10th day of May 1984.

Romer Robinson & Catterall, Plaintiff's Attorneys, Seventh Floor, Allied Building, Gardiner Street, Durban.

ORANJE-VRYSTAAT • ORANGE FREE STATE

Saak 2061/84

IN DIE LANDDROSHOF VIR DIE DISTRIK VAN WELKOM GEHOU TE WELKOM

In die saak tussen **United Bouvereniging**, Eksekusieskuldeiser, en **Mev. B. J. van Rensburg**, Eksekusieskuldenares

Ingevolge 'n Vonnis en 'n Lasbrief vir Eksekusie, gedateer 11 April 1984 in die Landdroshof te Welkom, sal die volgende eiendom verkoop word op die 22ste Junie 1984 om 11h00, te die Hoofregeringsgebou (Landdroskantoor), Welkom:

Sekere Erf 5386, Welkom, geleë te die Dorpsgebied van Welkom, distrik Welkom.

Straatadres: Kingstraat 102, Welkom, groot 833 (agthonderd drie en dertig) vk meters.

Onderhewig aan sekere Serwitute en gehou kragtens Akte van Transport No. T10417/1980, en geregistreer op 26 Augustus 1980.

Verbeterings: Woonhuis bestaande uit:

Een enkelverdieping woonhuis met baksteenmure, staal vensters en 'n geteelde dak. Die Hoofgebou bestaan uit 'n sitkamer, eetkamer, kombuis, drie slaapkamers en badkamer met 'n aparte toilet.

Buitegeboue: Bestaan uit 'n afsonderlike motorhuis van baksteenmure en 'n staal tipe dak sowel as 'n afsonderlike bediendekamer van baksteen met 'n staal tipe dak en 'n aparte toilet.

Addisionele inligting:

- (a) *Stadsbeplanning sonering:* Spesiale Residensiële.
- (b) *Spesiale voorregte of vrystellings toegestaan ten opsigte van die eiendom:* Geen.
- (c) *Groepsgebied:* Blank.
- (d) *Geleë te:* Naby skool, Sakesentrum en Motorhawe.

Voorwaardes van verkoping:

1. Die eiendom sal voetstoots en sonder reserwe verkoop word aan die hoogste bieder onderhewig aan die bepalings van die Wet op Landdroshof No. 32 van 1944, soos gewysig, en die Reëls daarkragtens uitgevaardig.

2. Die Koopprys sal as volg betaalbaar wees:

'n Deposito van 10 % (tien persent) van die Koopprys in kontant onmiddellik na afhandeling van die veiling en die onbetaalde balans tesame met rente daarop bereken teen 16,25 % (sestien komma twee vyf persent) per jaar tot datum van registrasie van transport sal binne 14 (veertien) dae betaal word of gewaarborg word deur 'n goedgekeurde Bank- of Bougenootskapwaarborg.

3. *Voorwaardes:*

Die volle verkoopsvoorwaardes wat deur die afslaer uitgelees sal word onmiddellik voor die verkoping kan gedurende kantoorure by die kantoor van die Geregsbode, Welkom, nagesien word.

Gedateer te Welkom, hierdie 1ste dag van Mei 1984.

M. J. Rossouw, Rossouw & Vennote, Prokureurs vir Eiser, Derde Verdieping, Unitedgebou, Posbus 455, Welkom, 9460.

Saak 531/1984

IN DIE LANDDROSHOF VIR DIE DISTRIK PARYS GEHOU TE PARYS

In die saak tussen **Die Suid-Afrikaanse Permanente Bouvereniging**, Eiser, en **André Gideon Nel**, Verweerder

Ingevolge 'n uitspraak van die bogenoemde Hof en 'n lasbrief, eksekusie, gedateer 7 Mei 1984, sal die volgende onroerende eiendom wat uitwinbaar verklaar is, op Woensdag, 27 Junie 1984 om 10h00, voor die Landdroshof, Parys, in eksekusie aan die hoogste bieder, verkoop word:

Erf 210, geleë in die dorp Parys, distrik Parys, groot 1 582 (eenduisend vyfhonderd twee en tagtig) vierkante meter.

Die volgende verbeteringe is na bewering op die eiendom aangebring maar niks in hierdie verband word gewaarborg nie:

'n Drieslaapkamerwoonhuis van baksteen.

Verkoopsvoorwaardes:

1. Die eiendom sal verkoop word aan die hoogste bieder en die verkoping sal onderworpe wees aan die bepalings van Artikel 66 van die Landdroshowewet No. 32 van 1944, soos gewysig, en die regte van die Verbandhouders en ander voorkeur skuldeisers.

2. Een-tiende van die koopprys sal betaal word in kontant of by wyse van 'n bankgewaarborgde tjek op die dag van die verkoping en die balans is betaalbaar binne 14 dae vanaf die verkoping aan kontant of by wyse van 'n bankwaarborg betaalbaar vry van kommissie te Parys teen registrasie van transport in naam van die Koper.

3. Volledige verkoopsvoorwaardes wat voor die verkoping deur die Geregsbode uitgelees sal word, lê ter insae by die kantoor van die Geregsbode, Parys, en by die Eiser se prokureurs.

4. Die eiendom word verkoop onderworpe aan die terme, voorwaardes en beperkings soos neergelê in die Tite[voorwaardes daarvan en die Koper sal verantwoordelik wees vir betaling van alle transportkoste, hereregte, agterstallige belastinge, diensgelde en enige ander bykomstige onkoste.

Geteken te Parys, op hierdie 16de dag van Mei 1984.

G. P. Mandelstam, vir De Villiers & Joynt, Eiser se Prokureurs, Dolfstraat 63, Parys.

Saak 1120/84

IN DIE LANDDROSHOF VIR DIE DISTRIK VAN VIRGINIA GEHOU TE VIRGINIA

In die saak tussen **Allied Bouvereniging**, Eiser, en **Mev. G. M. Krügel**, Verweerder

Ingevolge 'n vonnis in die Landdroshof vir die distrik van Virginia en Lasbrief vir Eksekusie, gedateer die 12de dag van April 1984, sal die volgende onroerende eiendom geregtelik verkoop word aan die hoogste bieder op die 6de dag van Julie 1984, om 15h00 te Valleyrylaan 41, Virginia, naamlik:

Erf 640, geleë in die dorpsgebied van Virginia, distrik Ventersburg, groot 1 318 vierkante meter, met verbeteringe daarop bestaande uit 'n woonhuis met buitegeboue.

Die vernaamste verkoopsvoorwaardes:

(1) Die Koper moet 10 % van die koopsom in kontant op die dag van verkoping aan die Geregsbode betaal;

(2) Die balans moet verseker word deur 'n bank- of bougenootskapwaarborg betaalbaar teen oordrag wat goedgekeur moet word deur die eksekusie-skuldeiser se prokureurs en wat binne veertien (14) dae na datum van die verkoping aan die geregsbode te Virginia gelewer moet word.

Voorwaardes van verkoop sal gedurende kantoorure by die kantore van die Geregsbode, Eerste Verdieping, Herculesgebou, Bullionstraat, Virginia ter insae lê.

Grunow Grunow & Maree, Prokureurs vir Eksekusieskuldeiser, Pretiumgebou, Posbus 123, Herdenkingstraat, Virginia.

Saak 1119/84

IN DIE LANDDROSHOF VIR DIE DISTRIK VAN VIRGINIA GEHOU TE VIRGINIA

In die saak tussen **Allied Bouvereniging**, Eiser, en **Mev. G. M. Krügel**, Verweerder

Ingevolge 'n vonnis in die Landdroshof vir die distrik van Virginia en Lasbrief vir Eksekusie, gedateer die 12de dag van April 1984, sal die volgende onroerende eiendom geregtelik verkoop word aan die hoogste bieder op die 22ste dag van Junie 1984, om 15h00 te Tulbachstraat 45, Virginia, naamlik:

Erf 2118, geleë in die dorpsgebied van Virginia, distrik Ventersburg, groot 1 002 vierkante meter, met verbeteringe daarop bestaande uit 'n woonhuis met buitegeboue.

Die vernaamste verkoopsvoorwaardes:

(1) Die Koper moet 10 % van die koopsom in kontant op die dag van verkoping aan die Geregsbode betaal;

(2) Die balans moet verseker word deur 'n bank- of bougenootskapwaarborg betaalbaar teen oordrag wat goedgekeur moet word deur die eksekusie-skuldeiser se prokureurs en wat binne veertien (14) dae na datum van die verkoping aan die geregsbode te Virginia gelewer moet word.

Voorwaardes van verkoop sal gedurende kantoorure by die kantore van die Geregsbode, Eerste Verdieping, Herculesgebou, Bullionstraat, Virginia ter insae lê.

Grunow Grunow & Maree, Prokureurs vir Eksekusieskuldeiser, Pretiumgebou, Posbus 123, Herdenkingstraat, Virginia.

Saak 690/1984

IN DIE HOOGGEREGSHOF VAN SUID-AFRIKA

(Oranje-Vrystaatse Provinsiale Afdeling)

In die saak tussen **J. J. Pieterse**, Eiser, en **G. H. Wurth**, Verweerder

Uit kragte van 'n Vonnis van die Hooggeregshof van Suid-Afrika (OVS Provinsiale Afdeling) en kragtens 'n Lasbrief tot Uitwinning, gedateer die 7de dag van Mei 1984, sal die volgende eiendom per publieke veiling vir kontant op Vrydag, die 22ste dag van Junie 1984 om 10h00 voormiddag, te die President Brandstraatingang, Hooggeregshof van Suid-Afrika, Bloemfontein, aan die hoogste bieder verkoop word, naamlik:

Sekere Erf 18137 (Bloemfontein Uitbreiding 121) geleë in die Stad en Distrik Bloemfontein, en beter bekend as Bokmakieriestraat 17, Fauna, Bloemfontein, Oranje-Vrystaat, groot 874 vierkante meter, gehou kragtens Transportakte No. T5172/1983, bestaande uit onder andere 'n ruim 3-slaapkamerwoning met studeerkamer, volle dubbel geriewe, dubbele motorhuis, houtplafonne, kombuis met aparte opwas, sit- en eetkamer ens.

Die verkoopsvoorwaardes is ter insae by die kantore van die Adjunk Balju, Posbus 237, Trustfonteingebou, St Andrewstraat, Bloemfontein, en/of Symington & De Kok, Tweede Verdieping, NBS-gebou, hoek van Elizabeth- en Wes-Burgerstraat, Bloemfontein, Oranje-Vrystaat, gedurende kantoor-ure.

P. A. C. Jacobs, vir Symington & De Kok, Tweede Verdieping, NBS-gebou, Elizabethstraat, Bloemfontein.

OPENBARE VEILINGS, VERKOPE EN TENDERS PUBLIC AUCTIONS, SALES AND TENDERS

TRANSVAAL

RENT-A-ROOF AFSLAERS

In opdrag van die Kurator in die insolvente boedel K. V. Russel-Smith verkoop ons per openbare veiling sonder enige reserwe die ondervermelde roerende bates op Donderdag 14 Junie 1984 om 10h00 te Van's Afslaers, Voortrekkerweg 522, Gezina, Pretoria.

Apex explorer yskas, klein houttafel, hout lessenaar, 4 kantoorstoel, Sharp fotostaatmasjien, 2 grys staal liasseerkabinette, bont mat, 15 kratte voorraad bestaande uit verbande, hegpleisters en elektroniese toerusting, 14 Raaco staalkassies met plastiese laaie, los staalraam houters, Sharp personeel rekenaar sisteem PC3201 plus staander, Tedelex elektroniese telefoon antwoordmasjien, Sharp PC1211 sakrekenaar met houer, karton LED Fassunger elektroniese komponente, karton multimeter instrument 80T—150 en 80J10, "Digital" multimeter, multimeter 8060A, Sprite musketeer woonwa Reg. No. DDG378T (1978).

Verkoopvoorwaardes.—Streng kontant of bankgewaarborgde tjek.

Vir verdere besonderhede skakel mnr. N. Vlok by Tel: 55-2059.

Rent-A-Roof Afslaers, Kamer 90, Salisburyhuis, Andriesstraat, Pretoria.

PILGRIMS REST DEVELOPMENT CO. (PTY) LIMITED, FORMERLY TRADING AS BRIANCOR MOTOR SPARES (IN LIQUIDATION), MASTERS REF No: T18/84

Duly instructed by the Liquidators in the above estate, we will sell by public auction on Friday 8th June 1984 at 10.00 a.m. at Aucor House, 31 Height Street, Doornfontein, Johannesburg.

As follows: Quantities of motor car spares, accessories, additives, lubricants, polishes and tools.

Terms.—Cash or bank guaranteed cheques only.

View.—Thursday 7th June 1984 from 9.30 a.m. to 4.30 p.m.

For further particulars, please contact the auctioneers.—Aucor (Pty) Limited, Aucor House, 31 Height Street, Doornfontein, Johannesburg. Tel: 724-5221. Telex: 450060.

PLASE TE KOOP

Op las van die Land- en Landboubank van Suid-Afrika sal die adjunk-balju Tzaneen op 29 Junie 1984 om 10h00 voor die Landdroskantoor te Tzaneen die ondergemelde eiendom/me by publieke veiling verkoop:

Die resterende gedeelte van Gedeelte 1 van die plaas Bergendal 489 Registrasie Afdeling L.T. Transvaal, groot 88,3827 hektaar.

Soos beskryf in Akte van Transport no. T43430/1976 geregistreer op 3 Desember 1976 in naam van Abraham Kuyper Smit (gebore 10 April 1920).

Die ligging van hierdie eiendom/me is soos volg:

16 km noordwes van Tzaneen, 9 km vanaf Polisiestasie.

Geboue en verbeterings wat beweer word om op die eiendom/me te bestaan is:

Woonhuis, buitekoelkamer, pakstoor met pakkamers, Bergstome, sementkanale, sementdam en 2 tenks.

Voornemende kopers se aandag word daarop gevestig dat daar geen verpligting op die Landbank rus om bakens of grense ten opsigte van die eiendom uit te wys nie.

Geen versekering kan gegee word dat die gemelde geboue en verbeterings wel bestaan, of dat enige daarvan vry van 'n retensiereg of huurkoop-ooreenkoms is, of dat 'n aangrensende eienaar geen belang of kontribusie-eis ten opsigte van 'n grensheining het nie.

Die eiendom/me word voetstoots verkoop soos dit staan, onderworpe aan alle serwitute en voorwaardes in die titelakte/s vermeld.

Die Voorwaardes van betaling van die koopsom is soos volg:

Een-vyfde van die koopsom tesame met alle kostes in verband met die verkoping insluitende advertensiekoste asook enige belastinge en afslaerskommissie teen 2½%, moet by toeslaan van die bot in kontant of per bank gewaarborgde tjek betaal word.

Die saldo van die koopsom, plus 12% rente daarop vanaf die datum van die verkoping tot datum van betaling, is binne 3 maande na die datum van die verkoping aan die Landbank betaalbaar.

Dit staan die koper vry om meer as die voorgeskrewe een-vyfde van die koopsom by toeslaan van die bot te betaal, en hy kan die saldo koopprys dadelik of te enige tyd voor verstryking van drie maande na die datum van die verkoping betaal.

Die koper is aanspreeklik vir die betaling van hereregte, transportkoste, belastinge, heffings, boedelregte en regeringslaste (as daar is) en enige ander gelde wat nodig mag wees om transport in sy naam te registreer. Die bedrae ten opsigte hiervan moet betaal word sodra die Landbank dit versoek.

Die Landbank behou hom die reg voor om enige eiendom wat te koop aangebied word te enige tyd van die verkoping te onttrek.

CONNIE J. VAN DER MERWE & CO—SALES

Public auction of fixed property (Luso Club) Tuesday 5th June 1984 at 11 a.m. on the spot Luso Club—Buffeldoorn Rd.

Duly instructed thereto by the Joint Liquidators, we will sell the Luso Club formerly known as the Leon Lewis Country Club, situated opposite Doornkruijn by public auction.

Fixed property:

Plot RE 377 situated in Buffeldoorn Rd, Klerksdorp. Measuring ± 11 hectar.

Improvements:

(a) Clubhouse consisting of a hall, kitchen and ablution block. Measuring ± 420 sq meter.

(b) Stable for 18 horses. Measuring ± 160 sq meter.

(c) Two houses for farm labourers.

(d) Borehole equipped with plenty water.

Auctioneers note.—This property is situated on a tarmac road adjacent to Flamwood and is ideally suited for township development. The state will be subject to approval by the Joint Liquidators. Inspection of the property may take place at any time. Condition of sale can be perused at the offices of the Auctioneer. For further information contact the Joint Liquidators, L. T. Herdan, Lurie & Co. Tel: 27418 or the Auctioneers. Tel: 24133.

TRAKMAN'S AUCTION SALES

Instructed thereto by The Liquidator of **Joe Moe (Pty) Ltd (In Liquidation) Master's Ref. T2055/83 t/a Speed Machines** the assets will now be sold at our mart 5 1st Street, New Doornfontein, Johannesburg on Tuesday 26th June, 1984 at 10.00 a.m.

Terms.—Cash. Phone 614-7135.

Trakman's Auctioneers (Pty) Ltd, Box 66267, Broadway, 2020.

QUALITY INVESTMENTS (PTY) LIMITED (IN LIQUIDATION) MASTER'S REF T36/84**AUCTION OF EXCELLENT INDUSTRIAL PROPERTY**

In Springs, being Stands, 17 & 18 New Era, Springs 17 and 18 Bell Road, New Era (South Main Reef Road, Springs).

Duly instructed by the Liquidators, **Rand Realty (Pty) Ltd**, in conjunction with Barnett Sales, will sell the above property by public auction, completely without reserve at 11.00 a.m. on Thursday, June 14, 1984 on the spot 17 Bell Road, New Era.

Area of Stand: $\pm 4\ 000\ m^2$ Zoned: special Industrial Improvements: $\pm 3\ 000\ m^2$ of Factories/Warehouses/Storerooms/Shops constructed from brick, plastered, with steel columns and saw-tooth roof, comprising 8 bays. Portion is let on a short term basis.

Potential gross annual income $\pm R150\ 000$.

Replacement value in excess of R1 Million.

Terms.—10% cash or bank guaranteed cheque on date of sale, balance by way of banker's guarantee within forty-five days.

Rand Realty (Pty) Limited, P.O. Box 1305, Johannesburg. Tel: 834-7484.

MANNIE AUCTIONEERING COMPANY

Insolvent estate **Jacobus Wynand Louw de Villiers No. T.968/84**.

Duly instructed by the Joint Provisional Trustee in the above matter we will sell by public auction on the spot, 5 Ernest Street, Kenleaf Extension, Brakpan, on Friday, 15th June, 1984, at 11 a.m. the following:

A large modern residence with pool and sauna—Kenleaf Extension, Brakpan.

Certain Stand No. 19 situate 5 Ernest Street, Kenleaf Extension, Brakpan, measuring approximately 1487 square metres upon which is erected a large modern residence and other improvements.

Terms.—10% deposit on signature of the Conditions of Sale and the balance within 21 days from date of confirmation.

Bond available to an approved purchaser.

For further particulars and viewing apply to the auctioneers.—Mannie Auctioneering Company, Auctioneers, Appraisers, Stock Liquidators and General Agents, 53 Troye Street (corner Pritchard Street), P.O. Box 9211, Johannesburg, 2000. Telephone: (011) 29-9617.

KAAP • CAPE**OPENBARE VEILING**

In die insolvente boedel van **Theunis Frederick Jacobus Swart Meester verwysing K.23/84**.

In opdrag van die Kurator in bogemelde boedel sal die navermelde goedere per openbare veiling verkoop word deur Mnr Van Niekerk Afslaaers (Eiendoms) Beperk, De Kockstraat 22, Posbus 284, Vryburg, op 12 Junie 1984 te die plaas "Content" in die distrik van Vryburg, te wete:

Voertuie, trekkers en implemente:

1978 model Mercedes Benz 240D, 1980 model Isuzi LAW, 2 1978 International Trekkers 844S, 2 Soilmaster Ploëë, 2 L M Stropers, grondbone plukker, 2 10 ton sleepwaens, 2 Vetsak Tilters, Soilmaster eenrigtingploeg, ontlaaiwa en 3 L M Planters.

Lewendehawe:

8 Koeie, 6 kalwers, 5 hans-kalwers en 2 verse.

Verkoopvoorwaardes.—Ter insae by die afslaaers te bogemelde adres of by Kurator te S.A. Permanentgebou, Derde Verdieping, Jonesstraat, Kimberley.

Terme.—Voetstoots teen kontant of gewaarborgde tjek.

NATAL

Duly instructed by the Provisional Liquidator of **Valiant Furniture Manufacturers (Pty) Ltd (In Liquidation) Masters Ref No. N175/84** we are selling at 133 Sirdar Road, Clairwood on Tuesday 26th June at 10.30 a.m.

Stock in trade, vehicles and machinery and we will also sell at 66 Pine Road, Clairwood on Tuesday 28th June at 10.30 a.m., immovable property and machinery as a whole subject to fourteen days confirmation also certain stock in trade and machinery.

Terms.—Cash.

For further details kindly contact the auctioneers.—Aucor (Pty) Ltd, 55 Alexandra Street, Durban. Tel: 317048.

ORANJE-VRYSTAAT • ORANGE FREE STATE**KENNISGEWING**

Geliewe kennis te neem dat die ondergetekende in sy hoedanigheid as Kurator in die insolvente boedel van **P. G. du Toit No. B59/83** van voorneme is binne ses (6) weke na datum van hierdie kennisgewing die bates wat oënskynlik aan mev L. F. du Toit behoort te gelde te maak. Mev du Toit se skuldeisers van waarde word versoek om hulle vorderings volgens die voorskrifte van Artikel 21 (3) by die ondergemelde te bewys.

Kurator—Insolvente Boedel, P. G. du Toit, Posbus 760, Bloemfontein.

NAAMSVERANDERING • CHANGE OF NAME**WET OP VREEMDELINGE, 1937**

Die onderstaande kennisgewings van voorneme om by die Staatspresident aansoek te doen om 'n ander van aan te neem, word ingevolge artikel 9 van Wet 1 van 1937 vir algemene inligting gepubliseer. Enigeen wat daarteen beswaar het dat die genoemde van aangeneem word, moet sy/haar beswaar met vermelding van redes daarvan so gou moontlik skriftelik by die Landdros genoem in die betrokke kennisgewing, indien.

Die inligting word, waar van toepassing, verstrekk in die volgorde: (1) Applikant(e) se volle name en van, en of minderjarige(s); (2) woonadres; (3) besigheid of beroep; (4) indien 'n aansoek ten opsigte van kinders onder 10 jaar, die naam (name); (5) die van wat aangeneem word; (6) die redes daarvoor; (7) die naam (name) voorheen gedra indien anders as onder (1) of (4), respektiewelik; (8) die name van vrou en kinders indien by die aansoek ingesluit; (9) bygestaan, indien so, deur; besware in te dien by die Landdros te.

THE ALIENS ACT, 1937

The undermentioned notices of intention to apply to the State President to assume a different surname are published in terms of section 9 of Act 1 of 1937. Any person who objects to the assumption of the said surname should lodge his/her objection, in writing, stating full reasons therefor, to the Magistrate mentioned in the relevant notice.

The information, where applicable, is given in the following order: (1) Full names and surname of applicant(s), and whether minor(s); (2) residential address; (3) business carried on, or occupation; (4) if an application in respect of children under 10 years, the name(s); (5) the surname to be assumed; (6) the reasons therefor; (7) the name(s) previously borne, if other than under (1) or (4), respectively; (8) the names of wife and children, if included in the application; (9) assisted, if so, by; objections to be lodged with the Magistrate of.

TRANSVAAL**THE ALIENS ACT, 1937****NOTICE OF INTENTION OF CHANGE OF SURNAME**

I, **Ismail Bulbulia**, residing at 31a Princess Avenue, Benoni, and employed as shop assistant, intend applying to the Minister of Internal Affairs for authority under section 9 of the Aliens Act, 1937, to assume the surname **Mahomed** for the reasons that I have always been known as **Mohamed** and so was my family. I previously bore the name **Bulbulia**. I intend also applying for authority to change the surname of my wife **Jubeldá** to **Mahomed**.

Any person who objects to our assumption of the said surname of **Mahomed** should as soon as may be lodge his objection, in writing, with a statement of his reasons therefor, with the Magistrate of Benoni.—J. Bulbulia, 22/5/84.

30-8

KAAP • CAPE**THE ALIENS ACT, 1937****NOTICE OF INTENTION OF CHANGE OF SURNAME**

I, **Milly Kasslem**, residing at 76 Blomvlei Road, Hanover Park, Lansdowne, 7764 and employed as Plumber, intend applying to the Minister of Internal Affairs for authority under section 9 of the Aliens Act, 1937, to assume the surname **Harris** for the reason that I was brought up as **Harris**. I previously bore the name **Nell Harris**. I intend also applying for authority to change the surname of my wife **Beverley Booysen** and minor child **Chesley**.

Any person who objects to our assumption of the said surname of **Harris** should as soon as may be lodge his objection, in writing, with a statement of his reasons therefor, with the Magistrate of Athlone.—Neil Harris, 28 May 1984.

8-15

THE ALIENS ACT, 1937**NOTICE OF INTENTION OF CHANGE OF SURNAME**

I, **Selwynne Crow**, residing at 32 27th Avenue, Elsie's River, Cape, and employed as clerk at the Department of Internal Affairs, 17 Roeland Street, Cape Town, intend applying to the Minister of Internal Affairs for authority under section 9 of the Aliens Act, 1937, to assume the surname **Crowe** for the reasons that the surname of Crow is a source of embarrassment to me. I previously bore the name **Crow**.

Any person who objects to my/our assumption of the said surname of **Crowe** should as soon as may be lodge his objection, in writing, with a statement of his reasons therefor, with the Magistrate of the District of Wynberg.—S. Crow, 22 May 1984.

8-15

DIE WET OP VREEMDELINGE, 1937**KENNISGEWING VAN VOORGENOME VANSVERANDERING**

Ek, **Harold Samuel Oliphant**, woonagtig te Meerhofstraat 15, Tafelsig, Mitchell's Plein wat werksaam is as opsiener te Pringle Transport, Epping is voornemens om by die Minister van Binnelandse Aangeleenthede aansoek te doen om magtiging kragtens artikel 9 van die Wet op Vreemdelinge, 1937, om die van **Oliver** aan te naam om die volgende redes: ek is sedert kinderjare en nog steeds alom bekend as **Oliver**; by my werkplek en vir belastingsaangeleenthede is ek bekend as **Oliver** en verder dat die van **Oliphant** vreemd is vir my. Ek het voorheen die naam gedra van **Oliphant**. Ek is voornemens om ook aansoek te doen om magtiging om die van van my eggenote **Hendrietta Petronella Oliphant**, gebore Gedult en minderjarige kinders **Karen**, **Moulca** en **Marlene Oliphant** te verander in **Oliver**.

Enigeen wat daarteen beswaar het dat ek bovermelde van **Oliver** aanneem, moet sy beswaar met vermelding van redes daarvoor, so gou moontlik skriftelik by die Landdros van Wynberg indien.—Harold Samuel Oliphant, 27/4/84.

8-15

DIE WET OP VREEMDELINGE, 1937**KENNISGEWING VAN VOORGENOME VANSVERANDERING**

Ek, **Manuel Mhuslanga**, woonagtig te 16a Athburg Walk, Hanover Park, Lansdowne wat werksaam is as binnemuur versierder is voornemens om by die Minister van Binnelandse Aangeleenthede aansoek te doen om magtiging kragtens artikel 9 van die Wet op Vreemdelinge, 1937, om die van **Nelson** aan te neem om die volgende redes; Die van **Mhuslanga** klink na 'n Bantoe van en my kollegas openbaar 'n minagende gevoel teenoor die van. Die van **Nelson** was my moeder se nooiensvan. Ek het voorheen die naam gedra van **Mhuslanga**. Ek is voornemens om ook aansoek te doen om magtiging om die van van my eggenote **Kathrina Jaftha** te verander in **Nelson**.

Enigeen wat daarteen beswaar het dat ek bovermelde van **Nelson** aanneem, moet sy beswaar, met vermelding van redes daarvoor, so gou moontlik skriftelik by die Landdros van Wynberg indien.—Manuel Mhuslanga, 2/11/83.

8-15

NATAL

THE ALIENS ACT, 1937

NOTICE OF INTENTION OF CHANGE OF SURNAME

I, **Johannes Mahlangu**, NIN 4784504 residing at Ntendeka Breary farm, employed by Metal Fabrications, P.O. Box 3811, Alberton, intends to apply to the Minister of Internal Affairs for authority under section 9 of the Aliens Act, 1937, to assume the surname **Zulu** for the reason that it is my father's surname. I previously bore the surname **Mahlangu**.

Any person who objects to my assumption of the said surname of **Zulu** should as soon as may be possible lodge his/her objections in writing with the reason therefore with the Magistrate Madadeni.

8-15

THE ALIENS ACT, 1937

NOTICE OF INTENTION OF CHANGE OF SURNAME

I, **Mahanand Ramtahal**, residing at 76 Emam Road, Raisethorpe, Pietermaritzburg, 3201, and employed as Laboratory Technician, University of Natal, P.O. Box 375, Pietermaritzburg, 3200, intend applying to the Minister of Internal Affairs for authority under section 9 of the Aliens Act, 1937, to assume the surname **Ram**, for the reason that all my brothers, Dr Sewbarath Ram, Rajilth Ram and Sathyapal Ram has been registered under the surname Ram, my junior and matric certificate results bear the surname of Ram and my father's business ran as Ram's Florist. I previously bore the name **Mahanand Ramtahal**.

Any person who objects to my assumption of the said surname of **Ram** should as soon as may be lodge his objection, in writing, with a statement of his reasons therefor, with the Magistrate of Pietermaritzburg.—M. Ramtahal, 19/5/1984.

8-15

THE ALIENS ACT, 1937

NOTICE OF INTENTION OF CHANGE OF SURNAME

I, **Karoline Michelle Alder**, a minor child residing at 36 Wildebees Street, Empangeni, intend applying to the Minister of Internal Affairs for authority under section 9 of the Aliens Act, 1937, to assume the surname of **Eisenstein** for the reason that my mother who is my legal guardian has remarried and I wish to assume the married surname **Eisenstein**. I previously bore the names **Karoline Michelle Alder**. I am being assisted in this application by my mother **Ise Michaela Eisenstein**.

Any person who objects to my assumption of the said surname of **Eisenstein** should as soon as may be lodge his objection, in writing, with a statement of his reasons therefor, with the Magistrate of Empangeni.—I. M. Eisenstein.

30-8

THE ALIENS ACT, 1937

NOTICE OF INTENTION OF CHANGE OF SURNAME

I, **Ise Michaela Eisenstein**, residing at 36 Wildebees Street, Empangeni, and employed as nursing sister, intend applying to the Minister of Internal Affairs for authority under section 9 of the Aliens Act, 1937, for my minor son **Michael Antony Alder** to assume the surname **Eisenstein** for the reason that I am his mother and legal guardian. I have remarried and I wish him to assume my married name **Eisenstein**. He previously bore the names **Michael Anthony Alder**.

Any person who objects to my assumption of the said surname of **Eisenstein** should as soon as may be lodge his objection, in writing, with a statement of his reasons therefor, with the Magistrate of Empangeni.—I. M. Eisenstein.

30-8

SLAGTERSKENNISGEWINGS • BUTCHERS' NOTICES

RAAD VAN BEHEER OOR DIE VEE- EN VLEISNYWERHEDE

Enige persoon wat beswaar het teen die oprigting, oordrag of verskuiwing van die vermeldde besigheid of die kansellasië van 'n registrasie kan sy beswaar indien in die vorm van 'n eedsverklaring, in drievoud, by die Raad se kantoor soos in die kennisgewing aangedui en binne die tydperk soos vermeld.

Die inligting word, waar van toepassing, verstrekk in die volgorde: (1) Dorpsgebied of distrik, afdeling, county; (2) applikant; (3) aard van aansoek (nuwe registrasie, oordrag, verskuiwing) en aard van besigheid; (4) besonderhede van perseel of plek (beskrywing, nommer, ligging en/of adres); (5) kansellasië van 'n registrasie (die perseel, indien anders as voorgaande, of wat laat vaar word vir verskuiwing) en/of nagesoek deur wie (volle naam); (6) besware aan en tydperk waarbinne.

LIVESTOCK AND MEAT INDUSTRIES CONTROL BOARD

Any person who has any objection against the establishment, transfer or removal of the business mentioned or the cancellation of a registration, may lodge such objection in the form of an affidavit, in triplicate, with the Board's office as indicated and within the period stated.

The information, where applicable, is given in the following order: (1) Township or district, division, county; (2) applicant; (3) kind of application (new registration, transfer, removal) and kind of business; (4) details of premises or place (description, number, situation and/or address); (5) cancellation of a registration (the premises, if other than the preceding, or quitted for removal) and/or by whom (full name); (6) objections to, and period within which.

TRANSVAAL

Boksburg. (2) Francois Jacobus Joubert. (3) Oordrag van eiendomsreg, kleinhandelslagter. (4) Mainstraat 7, Witfield, Boksburg. (5) Coenraad Jacobus Beukes Scholtz. (6) Takbestuurder, Posbus 4357, Johannesburg, 2000, 14 dae.

Phalaborwa. (2) Johan Strauss Schoeman en Andries Johannes Burger. (3) Nuwe aansoek, groothandelslagter. (4) Leydstraat 10, Phalaborwa. (5)—. (6) Hoofbestuurder, Posbus 40051, Arcadia, 0007, 30 dae.

Odi. (2) Sello Solomon Tau. (3) New application, retail butcher. (4) Portion 2b, 249 Klipgat, District of Odi. (5)—. (6) General Manager, P.O. Box 40051, Arcadia, 0007, 30 days.

Lichtenburg. (2) Jacobus Gerhardus Johannes Pretorius. (3) Oordrag van eiendomsreg, kleinhandelslagter. (4) Mellvillestraat 47, Lichtenburg. (5) Andries Beyers Plasie (Eiendoms) Beperk. (6) Hoofbestuurder, Posbus 40051, Arcadia, 0007, 14 dae.

- Pretoria.** (2) Hendrik Daniel Sassenberg. (3) Oordrag van eiendomsreg, kleinhandelslagter. (4) Voortrekkerweg 364, Gezina, Pretoria. (5) Francois C. R. Bodenstern. (6) Hoofbestuurder, Posbus 40051, Arcadia, 0007, 14 dae.
- Boksburg.** (2) Panayiotis Koukouves. (3) Transfer of ownership, retail butcher. (4) 192 Leeuwpoort Street, Boksburg South. (5) Frederick Johannes Hattingh. (6) Branch Manager, P.O. Box 4357, Johannesburg, 2000, 14 days.
- Vereeniging.** (2) Rahab Molefi. (3) Transfer of ownership, retail butcher. (4) Stand 1506, Togo Road, Evaton Township, District of Vereeniging. (5) John Kabode Molefi. (6) Branch Manager, P.O. Box 4357, Johannesburg, 2000, 14 days.
- Dalpark, Brakpan.** (2) Willem Hendrik Jansen van Vuuren. (3) Oordrag van eiendomsreg, kleinhandelslagter. (4) Winkel No. 4, Standplaas 922, Dalpark, Brakpan, hoek van Hendrik Potgieter- en Kareestraat, Dalpark, Brakpan. (5) Anthony Zackey en Filipe Manual da Silva. (6) Takbestuurder, Posbus 4357, Johannesburg, 2000, 14 dae.
- Dalpark, Brakpan.** (2) Anthony Zackey en Filipe Manual da Silva. (3) Oordrag van eiendomsreg, kleinhandelslagter. (4) Winkel No. 4, Standplaas 922, Dalpark, Brakpan, hoek van Hendrik Potgieter- en Kareestraat, Dalpark, Brakpan. (5) Wessel Green. (6) Takbestuurder, Posbus 4357, Johannesburg, 2000, 14 dae.
- Davel.** (2) Petrus Hendrik Kruger. (3) Verskuiwing van perseel, kleinhandelslagter. (4) Erf 385, Ermeloweg, Davel. (5) Erf 296, Newstraat, Davel. (6) Hoofbestuurder, Posbus 40051, Arcadia, 0007, 14 dae.
- Standerton.** (2) Standerton Varsprodukte (Eiendoms) Beperk. (3) Verskuiwing van perseel, kleinhandelslagter. (4) Erf 70, Uitbreiding 4, Standerton, hoek van Hartbeeslaan en Langebaanstraat, Standerton. (5) Erf 302, Kroghstraat 15, Standerton. (6) Hoofbestuurder, Posbus 40051, Arcadia, 0007, 14 dae.
- Middelburg.** (2) Gert Daniël Luus. (3) Oordrag van eiendomsreg, kleinhandelslagter. (4) Gedeelte 1, Erf 1590, Strelitziastraat 4, Kanonkop, Middelburg. (5)—. (6) Hoofbestuurder, Posbus 40051, Arcadia, 0007, 14 dae.
- Lichtenburg.** (2) Cape Hide and Skins, C. J. L. Greyling. (3) Nuwe aansoek, oordrag van eiendomsreg. (4) Plaas Houthaakdoring, distrik Lichtenburg. (5)—. (6) Hoofbestuurder, Posbus 40051, Arcadia, 0007, 30 dae.
- Thabazimbi.** (2) Cape Hide and Skins, C. J. L. Greyling. (3) Nuwe aansoek, oordrag van eiendomsreg. (4) Plaas Nooitgedact, distrik Thabazimbi. (5)—. (6) Hoofbestuurder, Posbus 40051, Arcadia, 0007, 30 dae.
- Wesselsbron.** (2) Cape Hide and Skins, C. J. L. Greyling. (3) Nuwe aansoek, oordrag van eiendomsreg. (4) Wesselsbron Slagplaas. (5)—. (6) Hoofbestuurder, Posbus 40051, Arcadia, 0007, 30 dae.

KAAP • CAPE

- Port Elizabeth.** (2) Joseph Leonard Clemans. (3) Oordrag van eiendomsreg, kleinhandelslagter. (4) Westbourneweg 55, Port Elizabeth. (5) Wessel Johannes Coleske. (6) Takbestuurder, Posbus 3100, Noordeinde, 14 dae.
- Oos-Londen.** (2) Francisco Eustaquio Figueira de Quintal. (3) Transfer of ownership, retail butcher. (4) Erf 14820, 19 Park Avenue, North End, East London. (5) Sams Foods (Pty) Limited. (6) Branch Manager, P.O. Box 3026, Cambridge, 5206, 14 days.
- Wynberg.** (2) Servus Butcheries (Proprietary) Limited. (3) New application, retail butcher. (4) Woolworths Store, 38 Main Road, Wynberg, Cape Town, Erf 66550, Wynberg. (5)—. (6) Branch Manager, P.O. Box 96, Maitland, 7405, 30 days.

NATAL

- Enseleni.** (2) Giles Ntuli. (3) New application, retail butcher. (4) Nhlanzini Reserve 4, District of Enseleni, under chief M. Mbuyazi, P.O. Box 10571, Meerence, Richards Bay. (5)—. (6) General Manager, P.O. Box 40051, Arcadia, 0007, 30 days.
- Howick.** (2) Humberto Rodrigues Coelho and Gideon Johannes Swart, trading as Savemore Supermarket and Butchery. (3) Transfer of ownership, retail butcher. (4) Shops 15 and 16, Lions River Shopping Centre, Somme Street, Howick. (5) S. W. Knowles (Proprietary) Limited. (6) General Manager, P.O. Box 40051, Arcadia, 14 days.
- Bulwer.** (2) Michael Patrick Mullane. (3) New application, retail butcher. (4) Bulwer Street, Lot 95, Bulwer. (5)—. (6) General Manager, P.O. Box 40051, Arcadia, 30 days.
- Isipingo.** (2) Wholesome Meats Distributors (Pty) Ltd. (3) New application, retail butcher, wholesale butcher, restricted to offal. (4) Shop 8, 1-5 Jeffells Road, Isipingo. (5)—. (6) Branch Manager, P.O. Box 2246, Durban, 30 days.
- Durban North.** (2) Terence Ackroyd Bell, Colin Ackroyd Bell, Derek Charles Jupp, Forry Marriot Road (Pty) Ltd. (3) Transfer of ownership, retail butcher. (4) Ellis Park Butchery, 31 Romsey Grove, Durban North. (5) Mladen Tomic. (6) Branch Manager, P.O. Box 10876, Marine Parade, 14 days.

ORANJE-VRYSTAAT • ORANGE FREE STATE

- Lindley.** (2) Viola Henriëtte Müller, née Müller. (3) Oordrag van eiendomsreg, kleinhandelslagter. (4) Die resterende gedeelte van Erf 2, geleë in die dorp Lindley ook bekend as George Lyonstraat 6, Lindley. (5) Johan George Steytler. (6) Hoofbestuurder, Posbus 40051, Arcadia, 0007, 14 dae.

ALGEMEEN • GENERAL

KAAP • CAPE

MUNISIPALITEIT KAAPSTAD

1984-06-08

WYSIGING VAN DIE REGULASIES TEN AANSIEN VAN DIE BEHEER OOR DIE STRAND EN DIE SEE WAT BINNE DIE REGSGEBIED VAN DIE MUNISIPALITEIT KAAPSTAD GELEË IS OF DAARAAN GRENS

Die Munisipaliteit Kaapstad het ingevolge artikel 10 (1) van die Strandwet, 1935 (Wet 21 van 1935), saamgelees met die voorgestelde wysiging van die Regulasies insake die Beheer oor die Strand en die See wat binne die regsgebied van die Munisipaliteit Kaapstad geleë is of daaraan grens soos gepubliseer op bladsy 56 in *Staatskoerant* 7607 van 1981-06-05 en met die goedkeuring van die Uitvoerende Komitee van die provinsie die Kaap die Goeie Hoop, genoemde regulasies gewysig deur die skraping van artikel 18 en die vervanging daarvan deur die volgende:

“18. HONDE

(a) Niemand mag toelaat of duld dat enige hond wat aan hom behoort of onder sy beheer is—

(i) enige pawiljoen, ingeslote baaiplek, swermdam of badhokkie binnegaan of daar bly nie;

(ii) in 'n baaigebied waar honde toegelaat word, ergenis aan persone veroorsaak of 'n oorlas is nie;

(iii) enige baaigebied binnegaan of daar bly nie ná die Raad kragtens besluit sodanige baaigebied omskryf het as 'n gebied waarin geen honde toegelaat word nie en kennis van sodanige omskrywing in die pers gegee is en 'n geskikte waarskuwingsbord of -borde in sodanige baaigebied opgerig is.

(b) Enige werknemer van die Raad kan, as 'n hond aangetref word in enige pawiljoen, ingeslote baaiplek, swermdam of badhokkie of in enige gebied waarin geen honde toegelaat word nie, of indien 'n hond in 'n baaigebied waar honde toegelaat word, ergenis veroorsaak aan persone of 'n oorlas is, beslag lê op sodanige hond en met hom handel ooreenkomstig die bepalinge van Artikel 5 van die Raad se Verordening insake die Beheer van Honde, ongeag of hy onder beheer is van sy eienaar of enige ander persoon wat sodanige hond vergesel.”

CAPE TOWN MUNICIPALITY

1984-06-08

AMENDMENT TO THE REGULATIONS IN REGARD TO THE CONTROL OF THE SEA-SHORE AND SEA SITUATED WITHIN OR ADJOINING THE AREA OF JURISDICTION OF THE CAPE TOWN MUNICIPALITY

The Cape Town Municipality has, in terms of section 10 (1) of the Sea-Shore Act, 1935 (Act 21 of 1935), read with the proposed amendment to the Regulations relating to the Control of the Sea-Shore and the Sea situated within or adjoining the area of jurisdiction of the Municipal Council of Cape Town as published on page 56 in *Government Gazette* 7607 of 1981-06-05, and with the approval of the Executive Committee of the Province of the Cape of Good Hope, amended the said regulations by the deletion of section 18 and the substitution thereof of the following:

"18. DOGS

(a) No person shall cause or suffer any dog belonging to him or in his charge—

(i) to enter or remain in any pavilion, bathing enclosure, pool or cubicle;

(ii) while in a bathing area where dogs are permitted, to cause annoyance to any person or to be a nuisance;

(iii) to enter or remain in any bathing area after the Council has by resolution defined such bathing area as an area in which no dogs are permitted and notice has been given in the press of the area so defined and a suitable sign or signs erected at such bathing area.

(b) Any employee of the Council may, if a dog be found in any pavilion, bathing enclosure, pool, cubicle or an area in which no dogs are permitted or if a dog in any bathing area where dogs are permitted causes annoyance to any person or is a nuisance, seize such dog and deal with it in accordance with the provisions of Section 5 of the Council's Dog Control By-Law whether or not it is in the charge of or accompanying its owner or any other person."

AANSOEKE OM REGISTRASIE VAN HANDELSMERKE IN SUIDWES-AFRIKA

(Aansoeke aangeneem ingevolge Wet 48 van 1973)

Enigiemand wat beswaar het teen enige van die onderstaande handelsmerke kan, binne die voorgeskrewe tydperk op vorm SM 6, vervat in die Tweede Bylae van die Handelsmerke-regulasies in Suidwes-Afrika, 1973, Kennisgewing van Beswaar indien. Die voorgeskrewe tydperk is twee maande na die datum van advertensie. Hierdie tydperk kan op aansoek deur die Registrateur verleng word.

Formele beswaar moet nie ingedien word voordat die applikant om registrasie per brief van die beswaar in kennis gestel is nie, ten einde hom in die geleentheid te stel om sy aansoek terug te trek voordat onkoste in verband met die opstel van 'n Kennisgewing van Beswaar aangegaan word. By gebreke van so 'n kennisgewing aan die applikant, kan koste teen die beswaarmaker uitgewys word.

"B" voor die nommer dui aan Deel B van die Handelsmerkregister.

REGISTRATEUR VAN HANDELSMERKE VIR SUIDWES-AFRIKA

APPLICATIONS FOR REGISTRATION OF TRADE MARKS IN SOUTH WEST AFRICA

(Applications accepted in terms of Act 48 of 1973)

Any person who has grounds for objection to any of the following trade marks may, within the prescribed time, lodge Notice of Opposition on form SM 6 contained in the Second Schedule to the Trade Marks Rules in South West Africa, 1973. The prescribed time is two months after the date of advertisement. This period may on application be extended by the Registrar.

Formal opposition should not be lodged until after notice has been given by letter to the applicant for registration so as to afford him an opportunity of withdrawing his application before the expense of preparing the Notice of Opposition is incurred. Failing such notice to the applicant an opponent may not succeed in obtaining an order for costs.

"B" preceding the number indicates Part B of the Trade Mark Register.

REGISTRAR OF TRADE MARKS FOR SOUTH WEST AFRICA

CLASS 8

83/1232 (SWA) in Class 8; hand tools and instruments; cutlery, forks and spoons; side arms; in the name of CLICKS STORES HOLDINGS (PROPRIETARY) LIMITED, a South African Company of 261 Victoria Road, Salt River, Cape Province, Republic of South Africa. Address for Service: MESSRS. ADAMS & ADAMS, Masada Building, Paul Kruger Street, PRETORIA.

SAFEWAY

Applicants admit that registration of this trade mark shall not debar other persons from the bona fide descriptive use in the ordinary course of trade of the word SAFE.

Associated with 83/1234 (SWA).

FILED: 30 NOVEMBER 1983.

CLASS 11

83/1234 (SWA) in Class 11; installations for lighting, heating, steam generating, cooking, refrigerating, drying, ventilating, water supply and sanitary purposes; in the name of CLICKS STORES HOLDINGS (PROPRIETARY) LIMITED, a South African Company of 261 Victoria Road, Salt River, Cape Province, Republic of South Africa. Address for Service: MESSRS. ADAMS & ADAMS, Masada Building, Paul Kruger Street, PRETORIA.

SAFEWAY

Applicants admit that registration of this trade mark shall not debar other persons from the bona fide descriptive use in the ordinary course of trade of the word SAFE.

Associated with 83/1235 (SWA).

FILED: 30 NOVEMBER 1983.

CLASS 5

84/0081 (SWA) in Class 5; pharmaceutical preparations; in the name of A. H. ROBINS COMPANY, INCORPORATED, a corporation organised under the laws of the State of Virginia of 1407 Cummings Drive, Richmond, Virginia 23220, United States of America. Address for Service: MESSRS. ADAMS & ADAMS, Masada Building, Paul Kruger Street, PRETORIA.

ROBITABS

Applicants undertake that, in use, the mark will only be applied to goods sold in tablet form.

Associated with 83/0871 (SWA).

Section 24 (1) (b) application.

FILED: 13 FEBRUARY 1984.

CLASS 34

83/1212 (SWA) in Class 34; tobacco, raw and manufactured including cigarettes, pipe tobacco, cigars, cigarillos and snuff; smokers' articles and matches; in the name of UNITED TOBACCO COMPANY LIMITED, a South African Company of Main Reef Road, Industria, Johannesburg, Transvaal Province, Republic of South Africa. Address for Service: MESSRS. ADAMS & ADAMS, Masada Building, Paul Kruger Street, PRETORIA.



FILED: 25 NOVEMBER 1983.

CLASS 19

84/0082 (SWA) in class 19: Building materials, natural and artificial stone, cement, lime, mortar, plaster and gravel; pipes of earthenware or cement; road making materials, asphalt, pitch and bitumen; portable buildings; stone monuments; chimney pots; all types of cement included in this class in the name of CEMENTOS MOLINS SOCIEDAD ANONIMA of Carretera Nacional 340, Km 329' 300 Sant Vicenc Dels Horts, Spain. Address for Service: Messrs. MacRobert, De Villiers & Hitge Inc, 601 United Building, 243 Pretorius Street, Pretoria.

ELECTROLAND

FILED: 14 February 1984.

CLASS 29

83/1070 (SWA) in class 29: Chips; in the name of IRVIN & JOHNSON LIMITED—a South African Company of Cape Town Centre, Heerengracht, Cape Town, Republic of South Africa. Address for Service: Messrs. Adams & Adams, Masada Building, Paul Kruger Street, Pretoria.

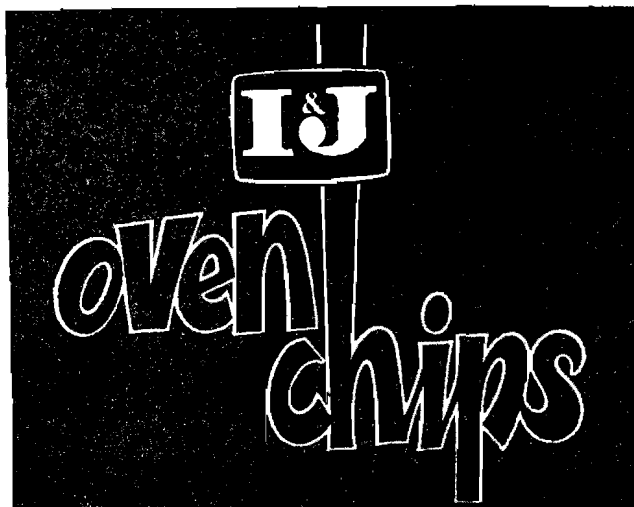

Registration of this trade mark shall give no right to the exclusive use of the letter "I", or of the letter "J", each separately and apart from the mark.

FILED: 12 October 1983.

CLASS 41

84/0080 (SWA) in Class 41; education and entertainment; in the name of THE DEVELOPMENT BANK OF SOUTHERN AFRICA—a non-statutory body established by Agreement and possessing juridical personality of West Street, Sandton, Transvaal, Republic of South Africa. Address for Service: MESSRS. ADAMS & ADAMS, Masada Building, Paul Kruger Street, PRETORIA.



Associated with 84/0077 (SWA).

FILED: 13 FEBRUARY 1984.

CLASS 36

84/0079 (SWA) in Class 36; insurance and financial; in the name of THE DEVELOPMENT BANK OF SOUTHERN AFRICA—a non-statutory body established by Agreement and possessing juridical personality of West Street, Sandton, Transvaal, Republic of South Africa. Address for Service: MESSRS. ADAMS & ADAMS, Masada Building, Paul Kruger Street, PRETORIA.



Associated with 84/0080 (SWA).

FILED: 13 FEBRUARY 1984.

CLASS 35

84/0078 (SWA) in Class 35; advertising and business; in the name of THE DEVELOPMENT BANK OF SOUTHERN AFRICA—a non-statutory body established by Agreement and possessing juridical personality of West Street, Sandton, Transvaal, Republic of South Africa. Address for Service: MESSRS. ADAMS & ADAMS, Masada Building, Paul Kruger Street, PRETORIA.



Associated with 84/0079 (SWA).

FILED: 13 FEBRUARY 1984.

CLASS 16

84/0077 (SWA) in Class 16; paper and paper articles, cardboard and cardboard articles; printed matter, newspapers and periodicals, books; book-binding material; photographs; stationery, adhesive materials (stationery); artists; materials, paint brushes; typewriters and office requisites (other than furniture); instructional and teaching material (other than apparatus); playing cards; (printers') type and cliches (stereo-type); in the name of THE DEVELOPMENT BANK OF SOUTHERN AFRICA—non-statutory body established by Agreement and possessing juridical personality of West Street, Sandton, Transvaal, Republic of South Africa. Address for Service: Messrs. ADAMS & ADAMS, Masada Building, Paul Kruger Street, PRETORIA.



Associated with 84/0078 (SWA).

FILED: 13 FEBRUARY 1984.

BOEDELWETTEKENNISGEWINGS ADMINISTRATION OF ESTATES ACTS NOTICES

Vorm/Form J 297

VERKIESING VAN EKSEKUTEURS, KURATORS EN VOOGDE

Aangesien die boedels van die persone hieronder vermeld nie verteenwoordig is nie word hierby deur Meesters van die Hooggeregshof van Suid-Afrika aan belanghebbendes kennis gegee dat byeenkomste ten opsigte van die verskillende boedels op die plekke, datums en tye vermeld, gehou sal word, met die doel om 'n persoon of persone te kies vir goedkeuring deur die onderskeie Meesters as geskik en bekwaam om deur hulle aangestel te word as eksekuteurs, kurators of voogde, na gelang van omstandighede, met aanduiding van die besonderhede in die volgorde: Boedelnommer, familie-naam en voorname van oorlede persoon, en beroep; datum van oorlye; plek, datum en tyd van byeenkoms.

In 'n plek waarin 'n kantoor van 'n Meester is, word die byeenkoms voor die Meester gehou en in ander plekke voor die Landdros.

L.W.—Items aan die linkerkant met 'n sterretjie (*) gemerk, dui aan die verkiesing van 'n voog of kurator; andersins word 'n eksekuteur gekies.

ELECTION OF EXECUTORS, CURATORS AND TUTORS

The estates of the persons mentioned below being unrepresented, interested parties are hereby given notice by Masters of the Supreme Court of South Africa, that meetings will be held in the several estates at the places, dates and times specified, for the purpose of selecting some person or persons for approval by the respective Masters, as fit and proper to be appointed by them as executors, curators and tutors, as the case may be, indicating the particulars as follows: Estate number, surname and christian names of deceased, and occupation; date of death; place, date and time of meeting.

Meetings in a place in which there is a Master's Office, will be held before the Master; elsewhere they will be held before the Magistrate.

N.B.—Items indicated by an asterisk (*) on the left-hand side denote the election of a tutor or curator; otherwise an executor is to be elected.

TRANSVAAL

- 105/55—*De la Guerra*, Hermanus William Hodges, boer. 23/12/84. Brits, 19/6/84, 10h00.
3795/76—*Master*, Arvind Bhikhabhai, director of company. 28/1/76. Johannesburg, 22/6/84, 09h00.
12696/81—*Kahn*, Bernard, self employed. 5/3/81. Johannesburg, 22/6/84, 09h00.
13125/78—*Winkle*, Stanley, area manager machinery. 5 November 1977. Pretoria, 20/6/84, 09h00.
4289/84—*Telxeira*, Manuel Simoa, shopkeeper. 31/3/84. Roodepoort, 20/6/84, 09h00.

KAAP • CAPE

- 80/111—*De Bene*, Ernest Henry, pensioner. 17/7/42. Cape Town, 12/6/84, 10.30 a.m.

Vorm/Form J 295

KURATORS EN VOOGDE: MEESTERS SE KENNISGEWINGS

Ingevolge artikel 75 van Wet 66 van 1965 word hierby kennis gegee van die aanstelling van persone as kurators of voogde deur Meesters, of van die beëindiging van aanstellings in sodanige hoedanighede.

Die inligting word verstrek in die volgorde: Nommer van saak; persoon onder kuratele, of minderjarige, en adres; naam en adres van kurator of voog; of aanstelling of beëindiging daarvan, en datum; Meester van die Hooggeregshof.

CURATORS AND TUTORS: MASTERS' NOTICES

In terms of section 75 of Act 66 of 1965 notice is hereby given of appointments of persons as curators or tutors by Masters, or of their having ceased in their respective capacity.

The information is given in the following order: Number of matter; person under curatorship, or minor, and address; name and address of curator or tutor; whether appointment or cease in capacity, and date; Master of the Supreme Court.

TRANSVAAL

- Myburg*, Johannes Frederik, Kurator, Gertina Myburgh, Mimosalaan 84, Proklamasie Heuwel, Pretoria. Aanstelling.
10809/75—*Hofman*, Herberdina Fillipina, Curator Bonis, Pieter Hofman, Geo. Isserow & T. L. Friedman, 546 Jules Street, Malvern, Johannesburg, 21 May 1984.

KAAP • CAPE

- 3415/81—*Marks*, Lowe. Curator, Raymond Mallach, c/o Buirski, Herbstein & IPP, Ninth Floor, Huguenot Chambers, 40 Queen Victoria Street, Cape Town. Cease, 26 May 1983, Cape Town.
5719/82—*Van Zyl*, Abraham Hendrik Petrus, Curator/Tutor, Raymond Mallach, c/o Buirski, Herbstein & IPP, Ninth Floor, Huguenot Chambers, 40 Queen Victoria Street, Cape Town. Cease, 9 August 1982, Cape Town.
2210/84—*Johnstone*, Hazel Maxine, born Vernon-Downey, 37 Edinburgh Court, Arthurs Road, Sea Point. Curator/Tutor, Alexander Gordon Dose, 14th Floor, Cartwright's Corner House, Adderley Street, Cape Town. Appointment, 10 May 1984, Cape Town.
3318/83—*Telle*, Maria Petronella Wilhelmina, Unit 17, Bergsig Garden Village. Curator/Tutor, Paula Lena Maria Meyer, born Telle, 21 Cedarberg Road, Durbanville Hills. Appointment, 30 June 1983, Cape Town.

OOS-KAAP • EASTERN CAPE

- 3359/81—*Molefe*, Khotso Alfred, Block 63, E2, New Brighton, Port Elizabeth. Curator/Tutor, Stephen Henry Levin, c/o East Cape Trustees (Pty) Ltd, A A House, 4 Rink Street, Port Elizabeth. Appointment, 4 November 1982, Grahamstown.
3478/80—*Cornellius*, Emmanuel, 25 Perla Street, Korsten, Port Elizabeth. Curator/Tutor, Stephen Henry Levin, c/o East Cape Trustees (Pty) Ltd, A A House, 4 Rink Street, Port Elizabeth. Appointment, 25 August 1982, Grahamstown.

NATAL

- 1758/84—**Challinor**, Anna Elizabeth, Morningside Nursing Home, 186, Innes Road, Durban. Curator, Abraham Willem Britz, 1103 Sanlam Centre, 331 West Street, Durban. Appointment, 16 May 1984, Pietermaritzburg.
 3908/76—**Moosa**, Ahmed, 11 Carden Crescent Parlock, Natal. Curator/Tutor, Ahmed Abdool Hack Mahomedy, P.O. Box 3268, Durban. Appointment, 3/4/84, Pietermaritzburg.

Vorm/Form J 193

KENNISGEWING AAN KREDITEURE IN BESTORWE BOEDELS

Alle persone wat vorderinge het teen die boedels hieronder vermeld, word hierby versoek om hul vorderinge by die betrokke eksekuteurs en binne 'n tydperk van 30 dae (of andersins soos aangedui) gereken vanaf die datum van publikasie hiervan in te lewer. Die inligting word verstrek in die volgorde: Boedelnommer, familienaam en voornaam, geboortedatum, persoonsnommer, laaste adres, datum oorlede; nagelate eggenoot(note) se name, familienaam, geboortedatum en persoonsnommer; naam en adres van eksekuteurs of gemagtigde agent, tydperk toegelaat vir lewering van vorderings indien anders as 30 dae.

NOTICE TO CREDITORS IN DECEASED ESTATES

All persons having claims against the estates mentioned below are hereby called upon to lodge their claims with the executors concerned, within 30 days (or otherwise as indicated) calculated from the date of publication hereof. The information is given in the following order: Estate number, surname and christian names, date of birth, identity number, last address, date of death; surviving spouse's names, surname, date of birth and identity number; name and address of executor or authorised agent, period allowed for lodgement of claims if other than 30 days.

TRANSVAAL

- 5059/84—**Vos**, Susara Johanna, 22/12/19, 1912220001007, 12de Laan 878, Wonderboom-Suid, Pretoria, 19 April 1984; Hermias Hendrik Vos, 22/12/19, 1808065001005. Macintosh Cross & Farquharson, Posbus 158, Pretoria.
 4076/84—**Flowerday**, Lawrence John, 11/8/15, 27A Essex Road, Burnside, Bulawayo, 5/11/84. Macintosh Cross & Farquharson, P.O. Box 158, Pretoria.
 2816/84—**Victor**, Gert Diederick, 7 Mei 1907, 075075015002, p/a Travryka Steenfabriek, Christiana, 24 Februarie 1984. Harrison, Marais & Mostert, Posbus 33, Christiana.
 2917/84—**Ochse**, Anna Susanna, previously Du Toit, born Van der Merwe, 18 March 1905, 0503180015003, widow, Bramley House, Bramley, Johannesburg, 30 January 1984. A. L. Mostert, c/o Couzyn, Hertzog & Horak Inc., P.O. Box 2242, Johannesburg.
 4382/84—**Faurie**, Wilhelmina Aletta, 26 Oktober 1936, 3610260009009, Pancroftstraat 5, Delareyville, 10 April 1984; Daniel Jacobus Faurie. Herman du Plessis & Seun, Posbus 23, Delareyville.
 4669/84—**Leonard**, Keith Walter Gordon, 1/1/16, 1601015019007, Late Harvest, Hartbeestpoort, District of Brits, 3 April 1984. Pim Goldby, P.O. Box 536, Benoni.
 4468/83—**Loubser**, Jan Petrus Daniël, 25 Januarie 1926, Darragh House 123, Wandererstraat, Johannesburg, 22 February 1983. Brandt & Oosthuizen, Posbus 599, Klerksdorp.
 4457/84—**Dippenaar**, Wessel Johannes Pieter, 30/11/06, 0611305024006, Steenbokstraat 2, Ventersdorp, 14/3/84; Catharina Margaretha Dippenaar, 6/4/13, 1304060039000. Santamtrust Bpk., Posbus 2144, Potchefstroom.
 3047/84—**Van Straaten**, Alfred, 16/1/13, 1301165039000, Duckhamstraat 16, Vanderbijlpark, 2/2/84; Susan Christina van Straaten, 12/7/16, 1607120053005. Santamtrust Bpk., Posbus 2144, Potchefstroom.
 5338/84—**Matthysen**, Andries, 26 Julie 1918, 1807265035001, Hoofweg 562, Erasmia, Pretoria, 27 April 1984; Catharina Johanna Maria Matthysen, voorheen Erasmus, gebore Meintjies, 27 Maart 1918, 1803270028000. Rein & Verster, Posbus 161, Pretoria.
 4525/84—**Mostert**, Tobias Jacobus, 9 Mei 1927, 2705095056000, George Duffstraat 76, Vanderbijlpark, 5 Februarie 1984; Hendrika Petronella Mostert, 24 Augustus 1927, 2708240003000. Sentrale Eksekuteurskamer Bpk., Posbus 84, Meyerton.
 878/84—**Rogers**, Johanna Maria Magdalena, 17/6/36, 3606170012000, Firrescent 5, Libanon, Westonaria, 13/1/84. Truter Crous Wiggill & Vos, Posbus 134, Westonaria.
 4630/84—**De Beer**, Johannes Diederik Pretorius, 6 Augustus 1915, 1508065014004, Sheldonstraat 119, Dominionville, 10 April 1984; Anna Jacoba de Beer, 25 Januarie 1921, 2101250005000. Volkskastrust Bpk., Posbus 970, Klerksdorp.
 4091/84—**Lötter**, Gertruida Elizabeth, 23 December 1905, 0512230014007, Presidentstraat 31a, Bloemhof, 22 Februarie 1984. Volkskastrust Bpk., Posbus 970, Klerksdorp.
 4499/84—**Volschenk**, Susanna Elizabeth, 26 Oktober 1925, 2510260064007, Kerkstraat, Amalia, 11 Februarie 1984; Philippus Johannes Volschenk, 25 Junie 1923, 2306255034000. Volkskastrust Bpk., Posbus 970, Klerksdorp.
 4640/84—**Engelbrecht**, Jurie Hendrik, 22/2/09, 0902225007001, Zeerusttehuis vir Bejaardes, 8/2/84; Martha Maria Engelbrecht, 28/12/13, 1312280005008. Volkskastrust Bpk., Posbus 970, Klerksdorp.
 4704/84—**Smit**, Willem Jacobus, 12/5/18, 1805125020009, Syferfontein, distrik Klerksdorp, 4 April 1984; Anna Maria Smit, 4/6/23, 2306040042003. Volkskastrust Bpk., Posbus 970, Klerksdorp.
 1948/84—**Niemann**, Hester Johanna Elizabeth, 20/7/17, 1707200053006, Christiaanstraat 854, Hercules, Pretoria, 23/11/82; Jan Sebastian Niemann, 21/9/05, 0511215030004. Vogel, Von Reiche & Van Oordt, Posbus 28742, Sunnyside.
 4292/83—**Downing**, Matthew William, 3 March 1937, 3703035092101, 23 Alouette Road, Impala Park, Boksburg, 4 February 1983. Slonowitz Dobie Smith & Myburgh Inc., P.O. Box 1882, Benoni.
 4010/84—**Spies**, Lodewyk Petrus, 17 September 1908, 0809175025000, Houtkopweg 59, Duncanville, Vereeniging, 25 Februarie 1984. De Klerk, Vermaak & Vennote Ing., Posbus 338, Vereeniging.
 960/84—**Crafford**, Hermanus Johannes, 11/2/67, 6702115072006, Marijistraat 152, Wonderboom-uitbreiding 2, 10 Januarie 1984. Couzyn, Hertzog & Horak, Posbus 3454, Pretoria.
 4735/84—**Ferreira**, Arthur Lopes, 24 January 1911, 1101245036103, 15 Rheims Road, Delville, Germiston, 28 March 1984; Albertina dos Santos Ferreira, 12 August 1912, 1208120069107. Wright, Rose-Innes, Louw & Wise, P.O. Box 123, Germiston.
 4618/84—**Whiting**, Mildred Eileen, 25 August 1904, 0408250015000, 7 Ambush Street, Kensington, Johannesburg, 28 March 1984. Wright, Rose-Innes, Louw & Wise, P.O. Box 123, Germiston.
 2420/84—**Buitendag**, Martha Magdalena Elizabeth, 29/3/1898, 357884393W, Robinson Hospital, Randfontein, 1/10/83. J. B. Hugo & Cronje, Posbus 115, Krugersdorp.
 1011/84—**Webb**, Helena Maria, voorheen Pienaar, gebore Buys, 19 Februarie 1901, 0102190003008, Huis Hoëveld, Rooseveltpark, Johannesburg, 26 Desember 1983. Marinus & Van der Spuy, Posbus 149, Pretoria.
 5073/84—**Van Wyk**, Petrus Johannes, 2 Junie 1921, 2106025014005, Plaas Rozenenthal, distrik Messina, 2 Mei 1984; Hendrina Maria van Wyk, 20 Julie 1940, 4007200049006. Jack Klaff, Posbus 1, Messina.

- 4080/84—**Van Heerden**, Jan Albert, 22/8/21, 2108225024008, Plot 220, Robsonweg, Hillside, Randfontein, 18/3/84. Truter Crous Wiggill & Vos, Posbus 134, Westonaria.
- 4226/84—**Groenewald**, Barendina Carolina, gebore Theron, 30 Januarie 1949, 4901300019006, St Albanstraat 102, Mayfair, Johannesburg, 6 Maart 1984. Boland Bank Bpk., Posbus 950, Pretoria.
- 16484/81—**Nicholas**, Susanna Magrietha, 23/2/31, 3102230018005, Plot 312, De Deur, 22 Mei 1981. Van Wyk De Vries, Posbus 5892, Johannesburg.
- 15252/83—**Arlow**, Wesselina Magdalena Arlow, 7/10/20, 2010070024002, 9 Pretorius Street, Geduld, Springs, 12 August 1983; Jan Johannes Arlow, 16/8/17, 1708165031003. Trollip, Joubert, Cowling & JANEKE, 125a Kingsway Avenue, Brakpan.
- 4401/84—**Kloppers**, Johannes Jacobus, 7/2/07, 0702075020009, Aristonweg 23, Selcourt, Springs, 4 April 1984. Ivan Davies Theunissen & Vennote, Posbus 16, Springs.
- 11866/83—**Nortje**, Ronald Ross, 15 Mei 1927, 2705155033006, Plot 163, Versterstraat, Puffontein, 8 Augustus 1983; Hendrietta Cornelia Nortje, voorheen Van der Walt, gebore Swanepoel, 24 April 1933, 3304240012008. Volkskastrust Bpk., Posbus 61488, Marshalltown.
- 4362/84—**Bosman**, Jan Christoffel, 9 Februarie 1914, 1402095006000, Foyelelaan 9, Crosby, Johannesburg, 17 Maart 1984; Catharina Maria Francina Cecillia Bosman, 3 Julie 1920, 2007030029006. Volkskastrust Bpk., Posbus 61488, Marshalltown.
- 3631/84—**Körner**, Frederick Petrus Jacobus, 23 November 1904, 0411235027009, San Franciscowoonstelle 205, Parklane, Parktown, 3 Maart 1984; Nellie Margaretha, gebore Van Heerden, 4 Desember 1905, 0512040027009. Volkskastrust Bpk., Posbus 61488, Marshalltown.
- 4390/84—**Grobler**, Willem Daniel, 14 April 1911, 1104145015003, Buffelspoort, Pk. Atlanta, 6/3/84; Rachel Sophia Elizabeth Grobler, 23 Februarie 1914, 1402230039007. Volkskastrust Bpk., Posbus 61488, Marshalltown.
- 4634/84—**Cassell**, Edward, 7 Mei 1936, 3605075044001, Derde Laan 50, Northmead, Benoni, 14 Maart 1984; Maria Magdalena Cassell, 19 Maart 1941, 4103190039006. Volkskastrust Bpk., Posbus 61488, Marshalltown.
- 3961/84—**Nagel**, Jacobus Stephanus Johannes, 17 Januarie 1936, 3601175034000, Lupinlaan 26, Primrose, Germiston, 16 Februarie 1984; Elsie Petronella Nagel, voorheen Geyer, gebore Nel, 25 November 1944, 4411250030009. Volkskastrust Bpk., Posbus 61488, Marshalltown.
- 3965/84—**Rossouw**, Abraham Gabriel, 12/2/27, 2702125043009, St Brideslaan, 31 Mayfair-Wes, Johannesburg, 14 Maart 1984; Gezina Johanna Rossouw, 18 Augustus 1928, 2808180079000. Volkskastrust Bpk., Posbus 61488, Marshalltown.
- 4628/84—**Böhmner**, Katherine Betty Charlotte Irmgard, 26 Julie 1900, 0007260002006, Maraisstraat 220, Brooklyn, Pretoria, 28 Februarie 1984. Volkskastrust Bpk., Posbus 1730, Pretoria.
- 7711/83—**Jacobs**, Anna Maria, 3 November 1912, 1211030051009, Lusthof, distrik Pretoria, 13 Januarie 1983. Volkskastrust Bpk., Posbus 1730, Pretoria.
- 7722/83—**Jacobs**, Cornelius Frederik, 7 September 1910, 1009075014001, Lusthof, distrik Pretoria, 1 Mei 1979; Anna Maria Jacobs, 3 November 1912, 1211030051009. Volkskastrust Bpk., Posbus 1730, Pretoria.
- 4591/84—**Van der Merwe**, Johanna Getruida, 6 Augustus 1904, Ceres, distrik Potgietersrus, 25 Januarie 1984. Volkskastrust Bpk., Posbus 1730, Pretoria.
- 3279/84—**Muller**, Matthys Johannes Uys, 28/3/23, 2303285051005, Daphnelaan 161, Mountain View, Pretoria, 16/12/83. Stegmanns, Posbus 344, Pretoria.
- 5080/84—**Bestbler**, Cornelis Johannes Alphonsus, 27/1/03, 0301275001008, Plot 172, Haakdoornboom, Pretoria, 17/4/84. Willem du Toit & Vennote, Posbus 29605, Sunnyside.
- 2687/84—**Boshoff**, Evert Philip, 26 Februarie 1913, 1302265023001, Elrinahof 1, Edwardstraat, Vereeniging, 27 Januarie 1984; Cornelia Jacoba Sacharia Boshoff. A. S. Scholtz & Scholtz, Posbus 1078, Alberton.
- 4675/84—**Malan**, Catharina Elizabeth, 21 Januarie 1900, 0001210001002, 21ste Laan 926, Rietfontein, Pretoria, 23 Maart 1984. Standardtrust Bpk., Posbus 1248, Bloemfontein.
- 11838/83—**Day**, John, 9/11/05, 0511095018004, Salvation Army, Simmondsstraat, Johannesburg, 4/8/83. Standardtrust Bpk., Posbus 1248, Bloemfontein.
- 2888/84—**Cockayne**, Eric Stanley, 18 April 1921, 2104185042106, Flat 1008, Maluti, Princes Avenue, Benoni, 1 August 1983. Hoffmann & Louis Stein, 45 Bedford Avenue, Benoni.
- 5648/84—**Venter**, Johannes Hendrikus, 6/11/17, 1711165009003, Gembokweg 76, Monumentpark, Pretoria, 4/5/84; Catharina Maria Venter, gebore Strauss, 27/4/13, 13042700360022. P. J. Dietrichsen, Herbert Bakerstraat 72, Groenkloof.
- 2533/84—**Mitchell**, Lida, 21/10/1893, 9310210005009, 45 Athlone Avenue, Sandringham, Johannesburg, 14 February 1984. Sylvia Oversby-Gerald Kalk, 6 Newlyn Centre, 40 Newport Avenue, Glenashley.
- 509/84—**Van den Berg**, Anna Johanna Catharina, 4 August 1893, 324888849W, Sunstraat 62, Sunnyridge, Germiston, 5 Januarie 1984. Schumann V. d. Heever & Slabbert, Posbus 67, Kempton Park.
- 15858/83—**Nunes**, Louis Jardine, 17 January 1961, 6101175138007, 363 Betty Street, Kloofsig, Pretoria, 21 July 1981. V. Borcherds & Ferreira, P.O. Box 186, Vanderbijlpark.
- 4780/84—**Jacobson**, Samson, 9 January 1912, 1201095021009, 360 Eastwood Street, Arcadia, Pretoria, 9 February 1984. Waks & Brady, P.O. Box 1861, Klerksdorp.
- 1092/84—**Cawood**, Cecil Albert Edward, 15 February 1903, 0302155008006, 4 Blyde Street, Stilfontein, 28 December 1983. T. Grobler & Co., P.O. Box 304, Klerksdorp.
- 3695/84—**Nelson**, Gert Zachariah, 31 Desember 1899, 334798017C, Kortstraat 4, Alabama, Klerksdorp, 3 September 1983; Kathrina Nelson, gebore De Koker, 5 April 1906, 334753043C. Waks & Brady, Posbus 1861, Klerksdorp.
- 13138/83—**Van Dyk**, Joseph Daniël, 13 November 1918, 1811135028008, Southsideweg 12, Blyvooruitsig, 15 Augustus 1983. Volkskastrust Bpk., Posbus 970, Klerksdorp.
- 4603/82—**Richards**, Michael Frederik, 20 Maart 1919, 1903205022001, Schoemanstraat 119, Potgietersrus, 28 Maart 1982. Lategan Espag & Geldenhuys, Posbus 387, Pietersburg.
- 4028/84—**Gerber**, Hester Johanna Hendrina, voorheen Baard, voorheen Koegelenberg, gebore Smit, 5/1/49, 4901050034003, Fochville, 11/3/84. Santamtrust Bpk., Posbus 2144, Potchefstroom.
- 2658/84—**Masango**, Petrus John, 1 January 1906, 109587411, 132 Zuma Section, Natalspruit, 30 January 1984. Stupel & Berman, P.O. Box 436, Germiston.
- 4420/84—**Müller**, Michael Arnoldus, 2 Junie 1909, 0906025007004, Georgestraat 4, Schweizer-Reneke, 23 Februarie 1984. Volkskastrust Bpk., Posbus 970, Klerksdorp.
- 5079/84—**Bouwer**, Hendrina Jacomina, gebore Lombard, 3 April 1909, 0904030009008, Ons Eie Woonstelle, Makwassie, 21 April 1984. Taljaard, Nieuwoudt & Van Tonder, Posbus 287, Wolmaransstad.
- 4368/84—**Van Wyk**, Carolina Wilhelmina, 28/4/28, 2804280039002, Plot Goedgenoeg, distrik Orkney, 19/2/84; Nicholaas Wilhelmus van Wyk, 7/5/34, 3405075058006. Santamtrust Bpk., Posbus 2144, Potchefstroom.
- 4358/84—**Van Wyk**, Nicholaas Wilhelmus, 7/5/34, 3405075058006, Plot Goedgenoeg, distrik Orkney, 19/2/84; Carolina Wilhelmina van Wyk, 28/4/28, 2804280039002. Santamtrust Bpk., Posbus 2144, Potchefstroom.
- 4919/84—**Stols**, Sophia Anna Margaretha, 27/9/11, 1109270041003, Sinnovillewoonstel 167, Pretoria, 25 Maart 1984. Volkskastrust Bpk., Posbus 970, Klerksdorp.
- 4214/84—**Willemsse**, Petrus Johannes, 7/9/05, 0509075038000, Gladstonelaan 19, Geduld-uitbreiding, Springs, 24/7/83. Volkskastrust Bpk., Posbus 970, Klerksdorp.
- 4668/84—**Koorzen**, Marthinus Johannes Jacobus, 9605045001002, Edith Smithouetehuis, Christiana, 21 Maart 1984. Volkskastrust Bpk., Posbus 970, Klerksdorp.

- 4115/84—**Strydom**, Aletta Catharina Wilhelmina, 25 September 1934, 356242778W, Andrew Murraylaan 4, Kookfontein, 11 Februarie 1984; David Roux Strydom, 3 Maart 1932, 32030350000. Sentrale Eksekuteurskamer Bpk., Posbus 84, Meyerfontein.
- 3639/84—**Naude**, Stephanus Jacobus, 7 Mei 1915, 1505075002003, Lambertleelaan 836, Parktown, Pretoria, 8 Maart 1984; Ella Dorothea Naude, gebore Krafft, 18 Maart 1914, 1403180003001. Du Randt & Louw, Posbus 26, Kroonstad.
- 2954/84/ASR2—**Joubert**, Josias Smuts, 24 November 1925, 2511245034008, 67 Ark Royal, corner of Petersen and Banket Streets, Hillbrow, Johannesburg, 25 Februarie 1984. C. W. Tasmer, P.O. Box 8, Kafferfontein.
- 4715/84—**Venter**, Carolina Ann, 18 Julie 1897, 464434193W, Hasivuna Plot 17, Tzaneen, 24/1/84. Rossouw & Venote, Posbus 455, Welkom.
- 3538/84—**Giesecke**, Diether Werner, 12 November 1911, 1111125016000, Die Plaas Laatsgevonden 13, Levubu, 7 Maart 1984. Coxwell & Steyn, Posbus 52, Louis Trichardt.
- 4645/84—**Gorman**, Charles Peter, 13 August 1952, 5208135036006, 154 Pretoria Road, Rynfield, Benoni, 1 April 1984. Slomowitz Dobie Smith & Myburgh Inc., P.O. Box 1882, Benoni.
- 4924/84—**Du Toit**, Anna Maria Elizabeth, voorheen Nieman, gebore Walters, 13 Oktober 1937, 3710130001002, Doornstraat 11a, Zeerust, 5 April 1984. Borman, Snyman & Barnard, Posbus 42, Potgietersrus.
- 4638/84—**Espach**, Wilhelmina Johanna, 17/8/26, 2608170018004, Perseel 142, Ivydale, 10/4/84; Hendrik Joachim Espach. Syfrets Trust Bpk., Posbus 1830, Pretoria.
- 3568/84—**Prinsloo**, Hester Dorothea, 24 Maart 1904, 0403240036000, Ons Tehuis, Soutpansbergweg, Riviera, 5 Februarie 1984. Syfrets Trust Bpk., Posbus 1830, Pretoria.
- 3122/84—**Ware**, Adelina Susana, 31/3/26, 2603310031009, 45a Kruger Avenue, Vereeniging, 10/284. Syfrets Trust Ltd, P.O. Box 1830, Pretoria.
- 3860/84—**Schoeman**, Elsje Cornelia Jacoba, 22/11/1895, 9511220001009, 33ste Laan 733, Villieria, 15/3/84; David Adolf Michael Botha Schoeman. Syfrets Trust Bpk., Posbus 1830, Pretoria.
- 1893/83—**Malleson**, Helen Rhoda, 12 March 1912, 1203120013007, Hazeldean Farm, Silverton, 9 January 1983. Savage Jooste & Adams Inc., 210 Permanent Buildings, Paul Kruger Street, Pretoria.
- 4468/84—**Jacobs**, Johanna Wilhelmina, 9 Maart 1899, 9903090016003, Vindhellaweg 11, Valhalla, Pretoria, 29 Oktober 1983. Haasbroek & Boezaart, Posbus 2205, Pretoria.
- 4859/84—**Buys**, Philippus Jacobus, 25 Junie 1917, 1706255025000, Plot 16, Phalaborwa, 26 Maart 1984; Anna Sophia Buys, 6 Oktober 1922, 2210060021006. Volkskastrust Bpk., Posbus 1730, Pretoria.
- 4032/84—**Lutschinski**, Herbert, 19 Desember 1924, 2412195013003, Wespark Mansions 5, Wespark, Pretoria, 28 Maart 1984. Couzyn Hertzog & Horak, Posbus 125, Pretoria.
- 3619/84—**Hefer**, Jacomina Hendrina, 0104230020000, Monicalaan 46, Flamwood, Klerksdorp. J. F. O. Friedrich, Posbus 3151, Pretoria.
- 4027/84—**Ferreira**, Salomo Petrus, 17 Julie 1933, 3307175062007, Koningin Wilhelminalaan 29, Lukasrand, Pretoria, 22 Februarie 1984; Hilda Florance Ferreira, gebore Donaldson, 12 Februarie 1927, 2702120010003. K. Kuyper & Kie., Posbus 175, Pretoria.
- 2414/84—**Van der Walt**, Benjamin, 30/7/33, 3307305046000, Sirkelstraat 21, Strubenvale, Springs, 1/1/84; Lorette Sussana van der Walt, 29/9/39, 3909290013001. Santamtrust Bpk., Posbus 1081, Kempton Park.
- 2742/84—**Obermeyer**, Martin Johannes, 4/2/38, 3802045055007, Vierdestraat 41, Northmead, Benoni, 12/12/83; Maria Jacoba Obermeyer, 18/8/40, 4008180037003. Santamtrust Bpk., Posbus 1081, Kempton Park.
- 3715/84—**Spies**, Daniël Jacobus Saayman, 20 Augustus 1921, 2108205015000, 11 Maart 1984; Cornelia Carolina Spies, 23 November 1924, 2411230021005. F. A. Jonker & Venote, Privaatsak X12038, Lichtenburg.
- 3640/84—**Oberholzer**, Catharina Francina, 28 Februarie 1927, 2708280049004, 7 Shirley Street, Homestead, Germiston, 4 March 1984; Evert Frederik Oberholzer, 29 September 1927, 2709295040004. Barclays National Bank Ltd, P.O. Box 2036, Johannesburg.
- 14620/83—**Greeff**, Petrus Johannes Hendrik, 15 Desember 1912, 1212155021009, 19 Arnoldi Street, Heidelberg, 31 Oktober 1983; Maria Janetta Sofia Greeff, 10 August 1923, 2308100006001. Barclays National Bank Ltd, P.O. Box 2036, Johannesburg.
- 3737/84—**Keel**, Marthina Cornelia, 14/12/44, 4412140003008, Impalapak, Boksburg, 24/2/84. Santamtrust Bpk., Posbus 602, Johannesburg.
- 12464/83—**De Bruin**, Elizabeth Francina, 28/9/1899, 331342741W, Dianastraat 13, Mayfair-Wes, Johannesburg, 5/7/83; Theunis Gert de Bruin, 4/3/05, 0503045036004. Santamtrust Bpk., Posbus 602, Johannesburg.
- Pieters**, Maria Catharina, 3/3/45, 4503030086002, La Chateauweg 25, Delville, Germiston, 18/4/84; Willem Johannes Pieters, 17/12/38, 3812175071005. Santamtrust Bpk., Posbus 1081, Kempton Park.
- 2300/84—**Swanepoel**, Pieter Gabriël, 15/11/17, 1711155016000, Charl Cilliersstraat 20, Boksburg-Noord, 30/12/83; Susanna Gesina Swanepoel, 30/7/20, 2007300022004. Santamtrust Bpk., Posbus 1081, Kempton Park.
- 2091/84—**Potgieter**, Alexander Philip, 26/10/14, 1410265039008, Windsorweg 89, Sunnyridge, 30/11/83; Catharina Elizabeth Gladys Potgieter, 27/11/19, 191127008003. Santamtrust Bpk., Posbus 1081, Kempton Park.
- 2701/84—**Coetzer**, Maria Elizabeth, gebore Roarty, 30/3/35, 3503300054004, Bothastraat 9, Brenthurst, Brakpan, 23/12/83; Johannes Hermanus Coetzer, 12/10/28, 2810125071002. Santamtrust Bpk., Posbus 1081, Kempton Park.
- 3311/84—**Birkenbach**, Andries Johannes Weens, 13 Februarie 1914, 1402135002001, Kareelaan 118, Proklamasieheuwel, Pretoria, 1 Maart 1984; Winifred Mary Birkenbach, gebore Cremen, 23 September 1925, 2509230001008. Santamtrust Bpk., Posbus 4680, Pretoria.
- 4683/84—**Van Niekerk**, Gert Petrus, 21 November 1904, 0411215001008, Die Botma-ouetehuis, Boksburg, 29 Maart 1984. Santamtrust Bpk., Posbus 4680, Pretoria.
- 4597/84—**Van Niekerk**, Renschie Maria, gebore Rose, 4 Februarie 1920, 2002040001004, Cilliersstraat 335, Lyttelton Manor, Verwoerdburg, 31 Maart 1984; Pieter Johannes van Niekerk, 23/2/20, 2002235002007. Santamtrust Bpk., Posbus 4680, Pretoria.
- 4774/84—**Engelbrecht**, Hendrina Dorothea, 18 Junie 1920, 2006180028008, Schuurmanlaan 725, Pretoria-Tuine, 12 Oktober 1983; Paul Jacobus Engelbrecht, 18 November 1921, 2111185022004. Santamtrust Bpk., Posbus 4680, Pretoria.
- 4636/84—**Dendy**, George Thamon Frederick, 6 Oktober 1928, 0610285022006, Charles Marberlystraat 27, Duiwelskloof, 20 Maart 1984; Ethel Dendy, 16 September 1913, 1309160034009. Santamtrust Bpk., Posbus 4680, Pretoria.
- 4553/84—**Biehler**, Alfred, 18/6/07, 0706185024009, 102 Parkston Drive, Blairgowrie, Randburg, 7 April 1984; Catharina Maria Biehler, 1806220030000. Syfrets Trust Ltd, P.O. Box 61058, Marshalltown.
- 3942/84—**Gosnell**, Annie Kathleen Maxwell, 5/8/1896, 960805003103, Jabula House, 10th Avenue, Rivonia, 28 Februarie 1984. Syfrets Trust Ltd, P.O. Box 61058, Marshalltown.
- 6200/84—**De Jager**, Christina, gebore Smith, 29/2/08, 0802290021004, Sunnyside Nursing Home, Kilfenorastraat 14, Lakefield, Benoni, 18/1/84. Boland Bank Bpk., Posbus 950, Pretoria.
- 2844/84—**Gerhard**, Johanna Katharina, 25 November 1908, Plot 102, Witpoort, District of Pretoria, 18 Oktober 1983. Savage, Jooste & Adams Inc., 210 Permanent Buildings, Paul Kruger Street, Pretoria.
- 734/67—**Schuler**, Walter Franz Gottfried, P.O. Box 143, Windhoek, 10 January 1965. Savage Jooste & Adams Inc., 210 Permanent Buildings, Paul Kruger Street, Pretoria.
- 596/84—**Haupt**, Fredrik John, 29 Januarie 1914, 140295025000, James Hyde Place 13, Montgomerypark, 8 Januarie 1984. E. H. Haupt, Posbus 3813, Randburg.
- 5562/83—**Speirs**, Robert Jobson Harrison, 15/4/44, 4404155084007, 1 Bethal Centre, Eeufees Street, Bethal, 16/4/83. Bisset, Boehmke & McBlain, P.O. Box 76, Cape Town.
- 2659/84—**Martin**, Albert Thomas, 29/5/12, 1205295023109, 1033 Regatta Road, Henley-on-Klip, 14/2/84. Steyn, Lyell & Marais, Posbus 83, Vereeniging.
- 4064/84—**Betts**, Lawrence Butler Bradford, 4 Augustus 1904, 0408045008005, Victorialaan 58, Vereeniging, 28 Maart 1984. Steyn, Lyell & Marais, Posbus 83, Vereeniging.

- 4801/84—**Schoeman**, Phillipus Albertus, 13/5/60, 6005135226002, Hoewe 84, Lusthof, Pyramid, 23 Maart 1984. Van Zyl, Le Roux & Hurter, Posbus 974, Pretoria.
- 5076/84—**Avelling**, David Jacobus, 26 September 1937, 3709265002009, Sewende Laan 1a, Kieserville, 31 Maart 1984. Standardtrust Bpk., Posbus 1330, Pretoria.
- 4817/84—**Bezuidenhout**, Magdalena Elizabeth Wilhelmina, 26/5/24, 2405260004006, Visagiestraat 12, Uitbreiding 8, Witbank, 15 Maart 1984; Hendrik Jacobus Bezuidenhout. Standardtrust Bpk., Posbus 1330, Pretoria.
- 12934/83—**Crampton**, Doreen Vivienne, 17 Derwent Lodge, Montagu Avenue, Harare, 6 August 1983. Standardtrust Ltd, P.O. Box 1330, Pretoria.
- 4643/84—**Funston**, Winniefred, 22 September 1909, 0909220014007, Hotel Hamsin, 675 Pretorius Street, 8 April 1984. Standardtrust Ltd, P.O. Box 1330, Pretoria.
- 5049/84—**Schutte**, Pieter Benjamin, 20/12/26, 2612205054000, Elandspruit, distrik Middelburg, 27 Maart 1984. Standardtrust Bpk., Posbus 1330, Pretoria.
- 5201/84—**Steenkamp**, Hermanus Philippus, 17 April 1899, 9904175002009, Wonderplaas, Ermelo, 6 April 1984; Anna Barbara Steenkamp. Standardtrust Ltd, P.O. Box 1330, Pretoria.
- 2492/84—**Van Tonder**, Paul Johannes, 17 Februarie 1932, 3202175014009, TPA-terrein, Brits, 15 Januarie 1984; Hester Susanna van Tonder. Standardtrust Bpk., Posbus 1330, Pretoria.
- 1923/84—**Honsal**, Karl Victor, 6/9/09, 0909065022107, 8 Cole Street, Kensington, Johannesburg, 17 January 1984; Gertrud Hedwig Honsal, 14/11/19, 1911140019107. Santamtrust Ltd, P.O. Box 602, Johannesburg.
- Price**, George Ralph Cornelius, 30 Julie 1924, 2407305010006, Georgetraat 23, Rosettenville-uitbreiding, 11 Januarie 1984; Aletta Johanna Dorothea Price, 20/1/25, 2501200018005. Santamtrust Bpk., Posbus 602, Johannesburg.
- Roux**, Rachael Johanna Jacomina, 28 Oktober 1919, Bordenweg 34, Florida-Noord, 10 November 1983. Santamtrust Bpk., Posbus 602, Johannesburg.
- 13889/83—**Kotze**, Maria Elizabeth Susanna, 25 April 1919, 1904250025006, Vierde Laan 3, Kieserville, Lichtenburg, 12 Julie 1983; Barend Christoffel Kotze, 27 Maart 1920, 2003275038000. Jan A. Lourens, Posbus 1275, Lichtenburg.
- 3835/84/ASR2—**Heymans**, Helena Elizabeth, 10/6/08, 0806100011006, Waterklooflandbouhoeve 62, Jochemstraat, Pretoria, 18/3/84. W. J. H. Pretorius, Posbus 25024, Monumentpark.
- 923/84—**Jansen van Rensburg**, Jacobus Frederik, 11 April 1908, 0804115001005, Kleinfontein, distrik Rayton, 3 Desember 1983; Elsie Maria Jansen van Rensburg, 5 November 1906, 0611050002009. Volkskastrust Bpk., Posbus 383, Pretoria.
- 3183/84—**Van der Watt**, Edwin Alfred Conroy Mariuz, 20 Mei 1915, 1505205035006, Rooielsstraat 1182, Môregloed, Pretoria, 9 Februarie 1984; Aletta Susanna van der Watt, gebore Pelsler, 2 November 1917, 1711020018009. Volkskastrust Bpk., Posbus 383, Pretoria.
- 4848/84—**Smith**, Samuel Christiaan, 9 April 1908, 0804095026006, Kerkstraat 1212, Colbyn, 1 April 1984; Debora Magritha Smith, 21 Mei 1915, 1505210056066. Volkskastrust Bpk., Posbus 383, Pretoria.
- 5406/84—**Prinsloo**, Catharina Maria, 24 September 1887, 8709240004000, Delareystraat 43a, Bronkhorstspuit, 7 April 1984. Volkskastrust Bpk., Posbus 383, Pretoria.
- 4624/84—**Alberts**, Cornelius Johannes Ignatius, 16 Desember 1904, 0412165017002, Hannystraat 964, Claremont, Pretoria, 17 Maart 1984; Jacomina Christina Alberts, 19 Desember 1910, 1012190001002. Volkskastrust Bpk., Posbus 383, Pretoria.
- 4789/84—**Steyn**, Francois Conradie, 8 Mei 1908, 0805085016006, Vyfde Laan 727, Mayville, 26 Februarie 1984. Volkskastrust Bpk., Posbus 1730, Pretoria.
- 4297/84—**Botha**, Jan Andries, 19 Julie 1915, 1506195015008, Des Fountainsingel 14, Minnebron, Brakpan, 25 Februarie 1984; Wilhelmina Mathea Johanna Botha, 19 Maart 1921, 2103190009001. Volkskastrust Bpk., Posbus 61488, Marshalltown.
- 4273/84—**Van Pletzen**, Andries Johannes Jacobus, 9 November 1912, 1211095042000, Greenhillweg 59, Greenside, Johannesburg, 11 Maart 1984; Abigaël Jacomina van Pletzen. Volkskastrust Bpk., Posbus 61488, Marshalltown.
- 4769/84—**Beukes**, Ester Magdalena, 11 Julie 1921, 2107110033009, Faraday Boulevard 159, Vanderbijlpark, 16 Maart 1984. Volkskastrust Bpk., Posbus 61488, Marshalltown.
- 1465/84—**Grobler**, Anna Dorothea, 4 Junie 1915, 1506040059002, Twomyrylaan, Wrightpark, Springs, 1/11/83. Volkskastrust Bpk., Posbus 61488, Marshalltown.
- 3003/84—**Geldenhuijs**, Andries Diederik Kruger, 24 Augustus 1939, 3908245069003, Carbonweg 120, Steelpark, Vereeniging, 8 Februarie 1984; Magdalena Maria Johanna Geldenhuijs, 1 April 1942 (Saam oorlede). Volkskastrust Bpk., Posbus 61488, Marshalltown.
- 1932/84—**De Kleyn**, Gerritjie, 6 June 1904, 0406060016002, 1 12th Street, Edenvale, Edenvale Old Age Home, 5 February 1984. Barclays National Bank Ltd, P.O. Box 2036, Johannesburg.
- 3056/84—**Trewhella**, Kathleen Eva, 23 November 1913, 1311230026007, 6 Harrowgate, Tyrwhitt Avenue, Rosebank, Johannesburg, 23 February 1984; Perry Trewhella, 9 February 1908, 0802095027008. Barclays National Bank Ltd, P.O. Box 2036, Johannesburg.
- 2822/84—**Williams**, William Fraser, 11 April 1918, 1804115010005, 31 Edwards Street, Witfield, 3 February 1984. Barclays National Bank Ltd, P.O. Box 2036, Johannesburg.
- 455/84—**Getz**, Oscar, 4/5/08, 040508, 14 Rose Road, Houghton, Johannesburg, 20/12/83. S. J. Ebedes, P.O. Box 6508, Johannesburg.
- 13961/83—**Carnell**, Reginald Charles, 9/10/1900, 0010095012000, 14 Seventh Avenue, Florida, 7/10/83. E. F. K. Tucker Nupen & Goodman Inc., P.O. Box 100, Johannesburg.
- 6536/83—**Limalia**, Assoo Bee, 14 March 1914, 800366830, 1 Chotoo Place, Malabar Hills, Isipingo, 17 November 1983. Essop-Limalia, P.O. Box 5161, Benoni South.
- 4922/84—**Sesel**, Sidney Sam, 11/1/29, 2901115043009, 108 Armadale Street, Sydenham, Johannesburg, 15/4/84. Eliasov, Wolf & Partners, P.O. Box 31740, Braamfontein.
- 15106/83—**Gobey**, Magdalena Adriana Fransina Corlina, 5 September 1904, 3356857630000, 53 Willoughby Street, Kenmare, Krugersdorp, 21 November 1983. Wackrill & Anderson, P.O. Box 961, Johannesburg.
- 5447/84—**Harris**, Violet Vergina (Virginia), 20 October 1908, 0810200036004, 11 Orlando Street, Kensington, Johannesburg. Cliffe Dekker & Todd, 108 Fox Street, Johannesburg.
- 385/84—**Belovay**, Elisabeth Alice, 22 September 1911, 1109220016008, 20 10th Avenue, Orange Grove, Johannesburg, 25 December 1983. Barclays National Bank Ltd, P.O. Box 2036, Johannesburg.
- 3591/84—**Auld**, John Leslie, 5/2/1899, 9902055001000, 22 Fiona Street, Discovery Extension 6, Roodepoort, 17/2/84. Standardtrust Ltd, P.O. Box 61452, Marshalltown.
- 3073/84—**Ferreira**, Miriam, born Le Roux, 2/4/15, 354824180, 14 Albertus Street, Extension 9, Carletonville, 1/10/83; Henning Jeremiah Ferreira, 15/7/15, 1507225010001. Standardtrust Ltd, P.O. Box 61452, Marshalltown.
- 4879/84—**Hort**, Hubert Augustine Ludwig, 30/3/1897, 9703305003006, 86 Daniel Malan Avenue, Florida Park, Florida, 19/3/84. Standardtrust Ltd, P.O. Box 61452, Marshalltown.
- 1926/84—**Irvine**, Alexander, 4 August 1947, 4708045161001, 20 St Frusquin Street, Malvern, Johannesburg, 17 January 1984. Standardtrust Ltd, P.O. Box 61452, Marshalltown.
- 3552/84—**Lawlor**, Vera Elizabeth, born Van Heerden, 16/5/30, 3005160044000, 106 Viljoen Street, Krugersdorp North, 17/1/84; Patrick Lawlor, 2/7/26, 2607025053000. Standardtrust Ltd, P.O. Box 61452, Marshalltown.
- 3580/84—**T'Hart**, Simon, 17/6/04, 0406175004006, 27 Balyard Court, Klerksdorp, 18/2/84; Ester Wilhelmina T'Hart, born Roscoe, 29/8/11, 1108290011006. Standardtrust Ltd, P.O. Box 61452, Marshalltown.
- 3497/84—**Mahomed**, Abdool Wahab, 5 January 1918, 1807055069057, 30 Kingfisher Street, Lenasia Extension 1, Lenasia, Johannesburg, 25 September 1983. Faruk Kajee, Ninth Floor, SARB House, 80 Commissioner Street, Johannesburg.
- 4680/84—**Mbata**, Mzululeki Ruben, 12/10/15, 110052391, 340 Central Western Jabavu, Soweto, 1 January 1984; Mabolani Elizabeth Mbata, V/F 1866847. R. I. Michel, P.O. Box 7602, Johannesburg.

- 4795/84—**Groome**, Gwendoline Ellen, 22/3/12, 1203220029002, 11 Japie Street, Rosettenville Extension, Johannesburg, 15 April 1984. Bowman Gilfillan Hayman Godfrey Inc., P.O. Box 1397, Johannesburg.
- 2791/84—**Strydom**, Ockert Jacobus, 23 April 1900, 0004235010008, Derde Straat 4, Krugersdorp-Noord, 13 Februarie 1984. Strydom & Kie., Posbus 11110, Brooklyn.
- 13454/82—**Van Greunen**, Coenraad Edward, 11/9/1898, 9809115012002, Plot 69, Klerksoord, Pretoria-Noord, 24/9/81. Ehlers & Vennote Ingelyf, Presidentsentrum 601, Pretoriusstraat, Pretoria.
- 4747/84—**Marais**, Daniel Christoffel, 27 Junie 1920, 2006275034002, Victoriastraat 22, Waterkloof, Pretoria, 4 April 1984. I. R. Coetzee, Theron van der Poel, Posbus 1093, Pretoria.
- 48991/84—**Maré**, Petrus Ignatius, 24 Oktober 1928, 2810245016001, Piet Retiefstraat 7, Nelspruit, 7 Maart 1984; Maria Wilhelmina Helena Maré, 10 April 1940, 4004100081007. Santamtrust Bpk., Posbus 2280, Middelburg.
- 3284/84—**Oosthuizen**, Johannes Hendrikus, 24/1/53, 5301245003006, Foskorwoonstelle, Phalaborwa, 31 Desember 1983. Santamtrust Bpk., Posbus 2280, Middelburg.
- 14937/83—**Van der Merwe**, Johanna Maria Jacoba, 20/11/16, 1611200029000, Pietersburgstraat 86a, Pietersburg, 14/6/79; Diederik Petrus Rudolph van der Merwe, 7/11/07, 0711075029001. Santamtrust Bpk., Posbus 2280, Middelburg.
- 15580/83—**Combrinck**, Janetta Wilhelmina Catharina, gebore Coomans, 27/6/23, 2306270003006, Derde Laan 98, Geduld, Springs, 24/9/83; Casper Jeremia Combrinck, 23/5/21, 2105235001000. Santamtrust Bpk., Posbus 1081, Kempton Park.
- 3513/84—**Van Staden**, Gert Johannes Benjamin, 2/3/18, 1803025028008, Plot 20, Grasland, Pk. Randfontein, 30/12/83. Santamtrust, Posbus 602, Johannesburg.
- 11652/83—**Hawkes**, Gertruida Johanna, 23/5/11, 1105230024008, Nigelweg 153, Selcourt, Springs, 9 Augustus 1983. Standardtrust, Posbus 61452, Marshalltown.
- 4869/84—**Fourie**, Isabella, 16/10/25, 2510160003006, Kylestraat 1, Glawdina, 16/3/84. Standardtrust Bpk., Posbus 61452, Marshalltown.
- 13072/83—**Van der Merwe**, Jan Hendrik, 11/6/31, 3106115026009, Wimmepegstraat 72, Raceview, Alberton, 23/9/83; Magdalena Susara Gertruida Johanna van der Merwe, 4/7/36, 3607040034000. Santamtrust Bpk., Posbus 1081, Kempton Park.
- 4857/84—**Bronkhorst**, Christine, 23/11/34, 341123002100, Fryerweg 21c, Casseldale, Springs, 20/2/84. Santamtrust Bpk., Posbus 1081, Kempton Park.
- 4187/84—**Pienaar**, Pierre Jacques, 18/10/49, 4910185074008, Vuurpyllaan 4, Verwoerdpark, Alberton, -/3/84; Gloria Pienaar, 19/11/48, 4811190079000. Santamtrust Bpk., Posbus 1081, Kempton Park.
- 3467/84—**Verhoef**, Johannes Petrus, 8 Mei 1963, 6305085165006, Derde Laan 43, Lambton, Germiston, 8 Februarie 1984. H. C. Pretorius & Kie., Posbus 3274, Kenmare, Krugersdorp.
- 4629/84—**Van den Berg**, Dirk Johannes, 14 September 1913, 1309145036004, Buitenstraat 84, Krugersdorp-Noord, Krugersdorp, 25 Maart 1984. Syfrets Trust Bpk., Posbus 61058, Marshalltown.
- 1642/84—**Williams**, Barend Michael, 5 November 1922, 2211055021001, Tonardo Park 12, Third Avenue, Georginia, Roodepoort, 14 January 1984; Anna Magrietha Williams, 24 Desember 1928, 2812240010005. Barclays National Bank Ltd, P.O. Box 2036, Johannesburg.
- 2228/84—**Nel**, Elizabeth Maria Margarieta, 22 March 1904, 043220032003, 23 Marthinus Street, Oberholzer, 11 February 1984. Barclays National Bank Ltd, P.O. Box 2036, Johannesburg.
- 7371/83—**Lombard**, Adriaan Jacobus, 10/11/31, 3111105036000, 184 Park Cres, Turffontein, 15/5/83; Myra Lombard. Standardtrust Ltd, P.O. Box 61452, Marshalltown.
- 4779/84—**Jooste**, Jacobus Francois, 14 Augustus 1921, 2108145002001, Njalastraat 62, Monumentpark, Pretoria, 8 April; Susarah Mareyna Jooste, 14 November 1928, 2811140002005. Santamtrust Bpk., Posbus 4680, Pretoria.
- 1232/84—**Labuschagne**, Willem Johannes Adrian, 15/2/56, 5602155071002, Sanguinestraat 2, Montroux, Johannesburg, 20/12/83. Barclays-Nasionale Bank Bpk., Posbus 40076, Arcadia.
- 3023/84—**Meyer**, Lewis Jacobus, 20/12/19, 1912205030005, 650 Wolhuterskop Avenue, Gezina, Pretoria, 25/2/84; Phyllis Adelaine Meyer. Barclays National Bank Ltd, P.O. Box 40076, Arcadia.
- 8472/83—**Macfarlane**, Sheila Marguerite, 9/5/02, 8 Coimbra Court, Wakefield Road, Avondale, Zimbabwe, 24/1/83. Barclays National Bank Ltd, P.O. Box 40076, Arcadia.
- 6581/83—**Bannister**, Martha Louise, 6/10/23, 2310060015006, Zwakfontein Trichardt, 19/5/83; Barend Jacobus Theunis Bannister. Barclays-Nasionale Bank Bpk., Posbus 40076, Arcadia.
- 10358/83—**Schoeman**, Evelina, 24/11/03, 0311240003005, Elandstraat, Hoedspruit, 6/8/83; Jacobus Johannes Schoeman. Barclays-Nasionale Bank Bpk., Posbus 40076, Arcadia.
- 5056/84—**Venditti**, Marisa, 7 October 1942, 4210070063103, 9 Malcolm Avenue, Southdale, Johannesburg, 7 April 1984. Lazzara & Leicher, P.O. Box 6522, Johannesburg.
- 4482/84—**Stewart**, Gerald Malcolm, 22 June 1926, 2606225004003, 28 Chapman Road, Klippoortje, Germiston, 2 April 1984. Webber Wentzel & Co., P.O. Box 61771, Marshalltown.
- 4623/84—**Ayers**, Alida Margaretha, 25/9/1895, 331191773W, Queen Alexandra Home, 80 Eighth Avenue, Orange Grove, Johannesburg, 5/4/1984. Markowitz & Jaffit, P.O. Box 7469, Johannesburg.
- 10506/76—**Govin**, Lakha, -/1/07, 800027559A, 4617 Lakspur Avenue, Lenasia Extension 3, 16 December 1975; Ratan Lakha Govin, 800027560. N. G. Patel Cachalia & Loonat, P.O. Box 25105, Ferreirastown.
- 4411/84—**Lampport**, Philip Edward, 30 April 1917, 1704305004000, 9 Seventh Avenue, Bezuidenhout Valley, Johannesburg, 31 March 1984; Marie France Irene Lampport, 1 August 1919, 1908010033002. Mrs M. F. I. Lampport, P.O. Box 1793, Johannesburg.
- 4455/84—**Crossland**, Stanley Cochrane, 29/3/17, 1703295034001, 17 Prentice Road, Greenside, 18/3/84. Bowens, P.O. Box 6434, Johannesburg.
- 2128/84/ASR3—**Chothia**, Ahmed Hassim, 12 June 1902, 0206265016058, 11 Minara Street, Azaadville, Krugersdorp, 26 December 1983. Dangor-Chunilal, 63 Avenue Road, Third Floor, Fordsburg.
- 4538/84—**Dos Santos**, Manuel Dias, 20 May 1939, 3905205034108, 72 Waterval Road, Newlands, 10 March 1984; Maria Gomes dos Santos. Barclays National Bank Ltd, P.O. Box 2036, Johannesburg.
- 4529/84—**Powell**, Barend, 7 January 1928, 2801075017003, 92 Seventh Avenue, Mellville, Johannesburg, 13 March 1984; Eleanor Diana Powell, 20 November 1929, 2911200051007. Barclays National Bank Ltd, P.O. Box 2036, Johannesburg.
- 2732/84—**Knoessen**, Christiaan Frederik, 5 February 1926, 2602055033006, Arnoldistadt, Kroondal, 12 February 1984; Emma Adriana Knoessen, 16 December 1929, 2912160031005. Barclays National Bank Ltd, P.O. Box 2036, Johannesburg.
- 2686/84—**Bach**, Marx, 11 August 1907, 0708115015008, Bodenstein Road, Wolmaransstad, 21 February 1984. Barclays National Bank Ltd, P.O. Box 2036, Johannesburg.
- 4897/84—**Makhlaku**, Tryphina Dora, -/1/1893, V/F1421122, Evaton Road, Evaton, Vereeniging, 14 March 1984. Wertheim Becker, P.O. Box 2102, Johannesburg.
- 4425/84—**Petre**, Colleen Elizabeth, 15 September 1942, 4209150060005, 21 Linden Road, Strathaven, 23 January 1984. G. B. Liebmann & Company, Third Floor, Glencairn, 73 Market Street, Johannesburg.
- 7434/83—**Barker**, Neil, 21 November 1937, 3711215005108, 21 Selwyn Hall, Dukes Avenue, Windsor Park, Randburg, 10 June 1983; Monika Christina Barker, 15/12/59, 5912150136100. Snaid & Snaid, P.O. Box 35362, Northcliff.
- 9199/83—**Grant**, James William, -/1/1879, 12 Park Lane, Timaru, New Zealand, 19 June 1969. Bowman Gilfillan Hayman Godfrey Inc., P.O. Box 1397, Johannesburg.
- 3676/84—**Le Grange**, Elsie, 6/8/10, 1008060012004, Plot 141, Zwavelpoort, District Pretoria, 6 March 1984. V. le Grange, P.O. Box 1793, Johannesburg.

- 3357/84—Melamed, Beryl, 28 September 1906, 0609280028000, 74 Taunton Place, Esselem Street, Hillbrow, 4 March 1984. Barclays National Bank Ltd, P.O. Box 2036, Johannesburg.
- 15948/83—Hofer, Gerhard Albrecht, 21 September 1922, 2109225013108, 27 St Patric Road, Hurlyvale, Edenvale, 11 November 1983; Magdalene Else Emilie Hofer, 901537774. Barclays National Bank Ltd, P.O. Box 2036, Johannesburg.
- 2611/84—Labuschagne, Jacobus Francois, 12 November 1926, 2611125014003, 3 Lake Cottage, Hamberg Road, Florida, 31 January 1984; Hester Sophia Labuschagne, 7 October 1924, 2410070023006. Barclays National Bank Ltd, P.O. Box 2036, Johannesburg.
- 13378/83/ASR3—Monsberger, Stefan, 15/8/06, 0608155026107, 31 Tregoning Street, Linksfield, 1 October 1983; M. L. Monsberger, 22/12/10. N. A. S. Monsberger, P.O. Box 16304, Doornfontein.
- 15662/83—Alexander, Nigel William Vereker, 14 September 1943, 4309145147105, 24 Buffalo Street, Wilbrow Park, Roodepoort, 7 November 1983. Barclays National Bank Ltd, P.O. Box 2036, Johannesburg.
- 2994/84—Colere, Walter Henry, 23 June 1898, 44 Ashford Road, Illovo, Johannesburg, 28 February 1984. Metboard Ltd, P.O. Box 32495, Braamfontein.

KAAP • CAPE

- 579/84—Philander, Piet Petrus Johannes, 23 November 1955, 5511235109015, Departement Natuurbewaring, Walvisbaai, 9 Oktober 1983. Andreas Vaatz, Posbus 23019, Widdhoek.
- 3235/84—Nelson, Juanita, 14/8/22, Perreirasingel 14, Kuilsrivier, 25/3/84; Jan Willem Petrus Nelson, 2/4/26, 2604025018000. Volkskustrust Bpk., Posbus 3981, Kaapstad.
- 735/84—Dippenaar, Anna Catharina Dorothea, 7/10/08, 0810070005006, Bainstraat 70, Wellington, 14/1/84. Volkskustrust Bpk., Posbus 3981, Kaapstad.
- 2954/84—Wessels, Johannes Marthinus, 22 April 1916, 1604225038007, 93 Davidson Road, George, 16 April 1984; Athene Margaret Wessels, born Combrink, 7 June 1922, 2206070051009, Raubenheimers, P.O. Box 21, George.
- 6858/83—De Wet, Jacobus Petrus, 24/2/1885, Boesmansrivier, distrik Bredasdorp, 6/8/62; Christina Magdalena de Wet, gebore De Kock. Lutrig & Seun, Posbus 21, Bredasdorp.
- 2946/84—Jackson, Cecilia Petronella, gebore Oosthuizen, 6/6/1898, 9806060001006, Huis Edwin Theron, Albertinia, 16/4/84. Boland Bank Bpk., Posbus 12, Riversdal.
- 3234/84—Mossop, Margaret Elizabeth, formerly Dommissie, born Goedhals, 13/9/1893, 9309130004001, Huis Vergenoegd, Main Street, Paarl, 2/5/84. Boland Bank Ltd, P.O. Box 236, Paarl.
- 4058/83—Liebenberg, Johan, 7/10/22, 2210075012008, Leonhof 20, Bellville, 24/5/83. Cape Trustees Bpk., Houtstraat 13, Kaapstad.
- 326/84—Jonker, Jozua Edward, 12 Augustus 1925, 2508125091017, Rose-Villa, Karooeweg 9, Crawford, 25 Desember 1983. Jan S. de Villiers & Seun, Posbus 1474, Kaapstad.
- 2655/84—Ackerman, Cornelius Petrus, 19/9/18, 1809195001006, De Hoek, Touwsrivier, 9/3/84; Helena Barendina Ackerman, 20/9/26, 2609200021000. Volkskustrust Bpk., Posbus 3981, Kaapstad.
- 3248/84—Langerman, Selwyn Maasdorp, 7 September 1904, 0409075011000, Ennerdale Nursing Home, Mowbray, 2 May 1984. Frank, Bernadt & Joffe, P.O. Box 252, Cape Town.
- 1355/84—Blumer, Wilhelm Johann Leonard, 22/10/12, 1210225037104, Rieslingstraat 19, Steynrus, Somerset-Wes, 23/1/84. Volkskustrust Bpk., Posbus 3981, Kaapstad.
- 2680/84—Marks, Mabel Irene, born Simpson, 18 November 1905, 0511180008001, Doordrift Lodge, Doordrift Road, Plumstead, 24 March 1984. Guthrie & Rushton, 102 Fish Hoek Centre, Main Road, Fish Hoek.
- 3087/84/ASR/G—Lourens, Philippus Coenraad, 21 Januarie 1941, 41012150430003, Fabriekstraat 17, Gansbaai, 31 Maart 1984; Maria Johanna Jacoba Lourens, gebore Van Zyl. Boland Bank Bpk., Posbus 34, Caledon.
- 3032/84—Esterhuysen, Lovina Elizabeth, 13/1/12, 1201130008009, Meulstraat 36, Caledon, 18/4/84. Guthrie & Theron, Posbus 17, Caledon.
- 3105/84—Kotze, Christiaan, 12 Junie 1963, 6306125074000, Langstraat 43, Vredenburg, 25 April 1984. Swemmer & Levin, Posbus 23, Vredenburg.
- 2788/84—Swiegelhaar, Abraham Cornelis, 9/3/09, 0903095024001, Standerhof 10, Voortrekkerweg, Parow, 27/2/84; Jeanette Susanna, gebore De Villiers, 28/9/16, 1609280045003. Volkskustrust Bpk., Posbus 3981, Kaapstad.
- Swart, Barend Christoffel, 20/6/16, 1606205010005, Langenhovenweg 130, Oudtshoorn, 20/4/84; Miriam Swart. Standardtrust Bpk., Posbus 765, George.
- 228/84—De Beer, Gysbert Johannes, 25/8/01, 0108255006000, Die Kruis, distrik Clanwilliam, 27/12/83; Sarah Jacomina de Beer, gebore De Waal, 11/8/1900, 026754259W. Boland Bank Bpk., Posbus 40, Vredendal.
- 1394/84—Wilsnack, Raymond Arthur, 14 Januarie 1933, 3301145065008, Parkersingel, Saldanha, 1 Januarie 1984. Swemmer & Levin, Posbus 23, Vredenburg.
- 3065/84—Boltaduros, Socrates Constantine, 25 Mei 1916, 1605255008000, Berg-en-Dal 1, Buitekringweg, Dalsig, Stellenbosch, 16 Maart 1984. Cluver & Markotter, Posbus 12, Stellenbosch.
- 2553/84—Markötter, Maria Jacoba, gebore Lochner, 12 April 1909, 0904120011005, Dorpstraat 159, Stellenbosch, 16 Maart 1984. Cluver & Markotter, Posbus 12, Stellenbosch.
- 2952/84—Steyn, Maria Johanna, 29 April 1920, 053238222W, Nuwurstehuis vir Bejaardes, Russelstraat, Worcester, 17 April 1984. Boland Bank Bpk., Posbus 32, Moorreesburg.
- 1612/84—Willemsse, Johanna Aletta (Johanna Willemsse), 2/9/28, 096757157, Fieldstraat 27, Paarl, 15 Desember 1983; Hendrik Marthinus Willemsse, 2/9/30, 3009025091016. Van der Spuy & Vennote, Posbus 218, Paarl.
- 3037/84—Maarman, Frederick William, 29/1/33, 3301295051014, Brandstraat 85, Bredasdorp, 9/4/84; Doris Naomi Maarman, gebore Moos, 3/4/41, 4104030051011. Boland Bank Bpk., Posbus 18, Bredasdorp.
- 827/84—Richards, John Lionel, 14 November 1904, 0411145018007, 29 Sunny Way, Pinelands, 23 January 1984. Walker Malherbe Godley & Field, 1505 Pleinpark, Plein Street, Cape Town.
- 3286/84—Matthee, Catharina Elizabeth, gebore Cronje, 9 September 1923, 2309090030001, Victoriastraat 104, Oudtshoorn, 19 Maart 1984; Christian Michael Mathee, 1502265035000. Santamtrust Bpk., Posbus 680, Bellville.
- Margetson, Mabel Janet, 2 July 1906, 356227956W, Panorama, Henley Road, Muizenberg, 22 April 1984. Barclays National Bank Ltd, P.O. Box 512, Cape Town.
- Salkinder, Leon, 8 April 1909, 0904085038001, 19 St Margaret Mansions, Sea Point, 17 April 1984. Barclays National Bank Ltd, P.O. Box 512, Cape Town.
- Meneses, John Louis Edward, 23 November 1909, 0911235019005, 66 Fairfield Road, Parow, 24 April 1984; Thelma Meneses. Barclays National Bank Ltd, P.O. Box 512, Cape Town.
- Smith, Graham Percival, 14 January 1901, 0101145011009, Rosedale Nursing Home, Kenilworth, 19 April 1984. Barclays National Bank Ltd, P.O. Box 512, Cape Town.
- Van Eyssen, Louis Frederick, 30 April 1922, 2204305038008, 80 Tafelberg Street, Bothasig, 23 April 1984; Elizabeth Cecelia van Eyssen, formerly Faria, born Hobbs. Barclays National Bank Ltd, P.O. Box 512, Cape Town.
- 3021/84—Marais, Nicolaas Hendrik, 3 Julie 1905, 0507035010002, Vrederus Ouetehuis, Villiersdorp, 24 Maart 1984; Anna Sophia Johanna Marais, gebore Krügel. Boland Bank Bpk., Posbus 34, Caledon.
- 1630/84—Owen, Cyril Arthur, 22/11/26, 1611265062007, 1 Garden Place, York Street, George, 24/2/84; Joyce Rosalini Owen. Standardtrust Ltd, P.O. Box 765, George.

- 2821/84—**Stanford**, Charles Evert (Everet) Athol, 29/11/18, 1811295018005, Ploverweg 42, George, 26 Maart 1984. Boland Bank Bpk., Posbus 373, George.
- 3042/84—**Reynolds**, Frances Irene Gertrude, 13 May 1903, 0305130021002, 2 Searls Terrace, Meyer Street, Mossel Bay, 3 April 1984. Boland Bank Ltd, P.O. Box 373, George.
- 3173/84—**Visagie**, Elias Jacobus, 16/9/20, 2009165051003, Sesde Laan 22, Kleinmond, 20 April 1984; Magritha Maria Visagie, gebore Fourie. Boland Bank Bpk., Posbus 34, Caledon.
- 2699/84—**Kruger**, Jacob Petrus, 25/6/27, 2706255005001, Kruger Huis, Laan Provence, Bell-Ombre, Constantia, 28/3/84. Volkskastrust Bpk., Posbus 3981, Kaapstad.
- 1772/84—**Gunter**, Hans Smal, 7/7/15, 1507075010002, Mullerstraat 15, Villiersdorp, 3/3/84; Wilhelmina Christina Gunter, 10/8/21, 2108100012003. Boland Bank Bpk., Posbus 34, Caledon.
- 2125/84—**Louw**, Jacobus Johannes, 5/10/15, 1610055004001, Koningstraat 17, Paarl, 5/3/84; Susanna Cornelia Louw, gebore Carstens, 12/9/24, 2409120029005. Boland Bank Bpk., Posbus 236, Paarl.
- 3069/84—**Francke**, Nolan John, 7/10/48, 4810075090017, Barracudastraat 2, Mosselbaai, 31/3/84; Johanna Francke, gebore Daniels, 14/10/50, 5010140063011. Boland Bank Bpk., Posbus 373, George.
- 2981/84—**Jordaan**, Gert Jacobus, 15 Februarie 1917. 1702155006000, Onverwags Williston, 11 April 1984; Anna Louisa Jordaan, gebore Beukes, 25 Oktober 1933, 3310250006004. Johannes G. Coetzee, Posbus 18, Carnarvon.
- 1120/84—**May**, Oktober, 15 Januarie 1945, 4501155085015, Haarlem, distrik Uniondale, 10 Desember 1983; Dina May, gebore Norte. G. G. Hough, Posbus 96, Uniondale.
- 3070/84—**Isaacs**, Joseph Jacob, 9/9/1918, 022833567K, Radion, 29 Lotus Road, Lansdowne, 24/4/84. D. P. de Klerk & Van Gend, Posbus 1857, Kaapstad.
- 288/84—**Collison**, William Charles, 20 August 1927, 2708205074004, 8 Talsen Mansions, Davenport Road, Vredehoek, 2 Desember 1983. A. Wagner de Villiers, 802 Protea Assurance House, 31 Adderley Street, Cape Town.
- 7676/83—**Martin**, Alexander Francis, 23 April 1906, 022279357, Almadu, Pinchurst Road, Lansdowne, 12 Oktober 1983; Magdalene Renetta Kathleen Martin, born Brindle, 24 November 1907. A. Wagner de Villiers, P.O. Box 179, Cape Town.
- 3154/84—**Ferguson**, Michael Lewis, 9/2/08, 0802095030002, Rondebosch Court 101, Main Road, Rondebosch, 29 April 1984. D. P. de Klerk & Van Gend, Posbus 1857, Kaapstad.
- 2451/84—**Sumner**, Haidee, born Burger, 22/7/09, 0907220008003, 30 San Bernardo, De Lorentz Street, Tamboerskloof, Cape Town, 4/4/84. Findlay & Tait Incorporated, 30 Hout Street, Cape Town.
- 3308/84—**Theys**, Morgasen Doorasawnii, 19 September 1927, 2709195051010, 66 Victoria Street, Somerset West, 23 April 1984. Morkel & De Villiers, P.O. Box 43, Somerset West.
- 2795/84—**Green**, Melville Graham, 2 March 1889, 8903025003002, Huis Esparanza, Donaldson Street, Strand, 27 March 1984. Rowan & Pullen, P.O. Box 85, Strand.
- 3128/84—**Jansen van Vuuren**, William Eugene, 29 Oktober 1946, 4610295021002, Adam Taslaan 111, Bothasig, 9 April 1984; Ellie Jacoba Aletta Wilhelmina Jansen van Vuuren, gebore Botha, 5103190013000. Santamtrust Bpk., Posbus 680, Bellville.
- 2866/84—**Topping**, Maria Magdalena, 13 Junie 1952, 5206130096009, 21ste Laan 62, Mosselbaai, 21 Maart 1984; Bryan David Topping, 5110255032007. Santamtrust Bpk., Posbus 680, Bellville.
- 2670/84—**Keyser**, Christian Jacobus, 11/5/09, 0905115028003, Hollandstraat 14, Kraaifontein, 5/4/84; Beatrix Susanna Margrietha Keyser, gebore Volschenk, 9/1/14, 1401090040006. Santamtrust Bpk., Posbus 680, Bellville.
- 2785/84—**Niewoudt**, Henry John Richard, 3 April 1964, 6404035120003, Meathstraat 10, Bellville, 12 April 1984. Santamtrust Bpk., Posbus 680, Bellville.
- 3244/84—**Jacobs**, Philippus Jacobus Petrus, 5/4/06, 0604055035009, Aiphen Hotel, P.O. Box 3, Constantia, 27/3/84; Anita Jacobs, formerly Bester, born Schell 28/5/17, 1705280036008. R. H. Meyeridricks, for Santamtrust Ltd, P.O. Box 4333, Cape Town.
- 3193/84—**Cloete**, Stephanus Petrus Malherbe, 16/3/1900, 0003165012000, Belle Ombrewoonstelle 12a, Gilmour Hillweg, Tamboerskloof, 9/4/84. R. H. Meyeridricks, vir Santamtrust Bpk., Posbus 4333, Kaapstad.
- Glenister**, Derrick Muirhead, 23/2/21, 2102235044007, 11 Oak Road, Glenbarrie, George, 13/5/84; Monica Elizabeth Glenister. Standardtrust Ltd, P.O. Box 765, George.
- Van Zyl**, Martha Maria Hendriina, 10/11/14, 1411100010006, Hillstraat 100, Mosselbaai, 4/5/84; Christiaan Jacobus van Zyl. Standardtrust Bpk., Posbus 765, George.
- 657/84—**Knoetze**, Matthys Johannes, 24/4/17, 1704245034000, Piet Retiefstraat 76, Parowvallei, 2/1/84. Santamtrust Bpk., Posbus 680, Bellville.
- 2920/84—**Moore**, Noel Drew, 13/2/18, 1802135012001, 15 Camdebo Avenue, Old Place, Knysna, 7 April 1984; Marguerite Helene Moore, born Lindsay, 19/2/22, 2202190010009. The Board of Executors, P.O. Box 86, Cape Town.
- 2351/84—**Sive**, Aaron, 4 January 1903, 0301045030006, A203 Emeraldine, Aliwal Road, Wynberg, 13 March 1984. The Board of Executors, P.O. Box 86, Cape Town.
- 2212/84—**Claassen**, Anna Hulda, 4/5/44, 4405040043009, 48 Woodlands Road, Woodlands Park, Wetton, 8/10/83; Harold Sydney Claassen, 9/7/37. Bisset, Boehmke & McBlain, P.O. Box 76, Cape Town.
- 3028/84—**McClean**, Frank Whipham, 17 January 1906, 331143239, 4 Uxbury, Main Road, Kenilworth, 21 March 1984. Silberbauers, P.O. Box 921, Cape Town.
- 3156/84—**Hills**, Kenneth Raymond Brydon, 23/2/22, 2302235030002, C8 Normanhurst, High Level Road, Sea Point, 28/4/84. Fairbridge, Arderne & Lawton, Fourth Floor, Main Tower, Cape Town Centre, Cape Town.
- 1135/84—**Seboa**, John Lukas, 23/5/23, 2305235052017, 15 Bamford Avenue, Crawford, Athlone, 25/7/83; Helen Sophia Seboa, born Theys. E. Moosa & Associates, P.O. Box 152, Athlone.
- 7135/83—**Dauids**, Aslam, 26/4/48, 4804265107020, Afwan, Sixth Avenue, Grassy Park, 20/8/1883; Asa Dauids, born Majal. Omar, Vassen, Sonn & Abercrombie, P.O. Box 187, Salt River.
- 3205/84—**Singer**, Marcus Louis, 30 July 1916, 1607305032006, 7 Wraysbury Gardens, Wraysbury Close, Newlands 30 April 1984; Joan Singer, born Cook. Gelb Gelb Simon & Shapiro, French Bank Building, 4 Church Square, Cape Town.
- 3155/84—**De Gruchy**, Coonstance Havergal, 11 June 1900, 901517089W, 602 Pleasant Ways, Beach Road, Sea Point, 11 April 1984. Sonnenberg Hoffmann & Galombik, 54 Shortmarket Street, Cape Town.
- 1839/84—**Thormählen**, Carl August, 3/6/18, 1806035017101, L9 Midmarweg, Groenvallei, Bellville, 5/3/84; Alida Johanna Thormählen, gebore Loubser. Syfrets Trust Bpk., Waalstraat 24, Kaapstad.
- 2736/84—**Du Toit**, Anna Margaretha Elizabeth, gebore Van Eeden, 20/4/06, 0604200026002, Huis Disa, Tulbagh, 11/4/84. Syfrets Trust Bpk., Waalstraat 24, Kaapstad.
- 2846/84—**Du Toit**, Salome, 29/12/29, 2912290020001, 12 Mossiestraat, Rawsonville, 13/4/84; Francois Petrus du Toit. Syfrets Trust Bpk., Waalstraat 24, Kaapstad.
- 8124/83—**Minnaar**, Claudia Veronica, gebore Moll, 24/9/1890, 096714647W, Huis Vergenoegd b4, Hoofstraat, Paarl, 29/9/84. Syfrets Trust Bpk., Waalstraat 24, Kaapstad.
- 3186/84—**Simpson**, John William, 27 April 1890, 9004275002007, Oakleigh Rest Home, 34 Pillans Road, Rosebank, Cape Town, 1 May 1984. Henry J. Barnett & Co., P.O. Box 2039, Cape Town.

- 2503/83—**Misplon**, James George, 31/5/11, 1105315034005, 17 Paul Kruger Street, Parow Valley, 30/3/84; Anna Margareta Johanna Misplon, formerly Tucker, born Du Toit, 1310090031008. Syfrets Trust Ltd, 24 Wale Street, Cape Town.
- 2612/84—**Hill**, Jenepher Roche, 2/1/30, 3001020555005, 67 Sandown Road, Rondebosch, 31/3/84. Syfrets Trust Ltd, 24 Wale Street, Cape Town.
- 2615/84—**Mackay**, Neil St Clair, 13/4/1886, 096715029W, Booth Memorial Hospital, Kloof Street, Gardens, 7/4/84. Syfrets Trust Ltd, 24 Wale Street, Cape Town.
- 3132/84—**Galloway**, Leonard Andrew, 11/7/08, 0807115004002, Inchcolm, King Road, Hout By, 23/4/84. Syfrets Trust Ltd, 24 Wale Street, Cape Town.
- 2712/84—**Franz**, Elizabeth Kemp, born Murray, 27/5/1894, 356211874, Murambi House, Wynberg, 12/4/84. Syfrets Trust Ltd, 24 Wale Street, Cape Town.
- 2635/84—**Windell**, Arthur William, 6/11/07, 0711065021000, 9 Aloe Street, Devil's Peak, 28/3/84; Elizabeth Maria Windell, born Visagie, 1108040039000. Syfrets Trust Ltd, 24 Wale Street, Cape Town.
- 121/67—**Byrnes**, Gilbert Carey, 28 April 1897, Avalon, Clifton Terrace, Observatory, 21 December 1966; Margaret Kays Byrnes, 23 April 1903, 075463004W. Sonnenberg Hoffmann & Galombik, 54 Shortmarket Street, Cape Town.
- 3185/84—**Penso**, Felice Fortunato, 25/1/01, 0101255013001, 51 Ocean View Drive, Green Point 28 April 1984; Maria Penso, born Isola. Syfret Godlonton-Fuller Moore Inc., P.O. Box 455, Cape Town.
- 3318/84—**Rom**, Arnold, 28/8/10, 1008285001006, 603 Twin Towers South, Beach Road, Sea Point, 4 May 1984. Gelb Gelb Simon & Shapiro, French Bank Building, 4 Church Square, Cape Town.
- 2757/84—**Rorich**, Irene Kathleen, born Van Rensburg, 21 April 1908, 0804210024001, 205 El Rio, Main Road, Sea Point, 7 April 1984. Sonnenberg Hoffmann & Galombik, 54 Shortmarket Street, Cape Town.
- 3176/84—**Hart**, Lazarus (Lawrence), 25 February 1893, 9302255008006, Ennerdale Nursing Home, Mowbray, Cape Town, 1 May 1984. Gross, Hendler & Frank, Greenmarket Place, 54 Shortmarket Street, Cape Town.
- 8505/83—**Howell**, Norman Owen, Avondster, Klein Constantia Road, Constantia. N. R. B. Douglas, P.O. Box 1743, Cape Town.
- 7795/82—**Low**, Simon Johan, 18 Karmel Street, Alabama, Klerksdorp. Buchanans Incorporated, 101 Medical Centre, Main Road, Wynberg.
- 2367/84—**Calnan**, Bernard Patrick, 18/6/06, 12 Glen Vlova Avenue, Highlands, Harare, 17/6/83. Syfrets Trust Ltd, 24 Wale Street, Cape Town.
- 429/84—**Maroon**, Isaac, 7 May 1910, 1005075030013, Dunbar Avenue, Athlone, 23 December 1983; Maud Regina Maroon, born West. Haydn Elmes & Elmes, P.O. Box 11072, Vlaeberg.
- 2979/84—**Basson**, Jurgen Kotze, 7/5/02, 0205075012000, Rock View, Yzerfontein, 11/4/84. Greenwood Poulton Trust (Edms.) Bpk., Posbus 3311, Kaapstad.
- 3124/84—**De Goede**, Edith Margaret, 2/6/10, 1006020042004, 9 Wessels Street, Napier, 7/4/84; Hendrik Nicolaas Jacobus de Goede, 14/3/08, 0803145031008. J. L. Martinson & Co., 717 Grand Parade Centre, Adderley Street, Cape Town.
- 3029/84—**Karbet**, Percy, 4/1/04, 0401065024002, 201 Curzon Place, Beach Road, Sea Point, 29 April 1984. Arthur E. Abrahams & Gross, 54 Shortmarket Street, Cape Town.
- 2962/84—**Nel**, Johannes Jacobus Lock, 24 Junie 1905, 0506245026006, Hoogstraat 8, Lutzville, 13 April 1984; Maria Susanna Aletta Catharina Nel, gebore Scheepers. E. v. d. M. Louw, Posbus 56, Loeriesfontein.
- 2094/84—**Appolis**, Simon Hermanus, 15 Oktober 1919, 1910155072019, Siriusstraat 80, Surrey Estate, Athlone, 14 Maart 1984. G. J. Roux, Marais Müller, Saambougebou 301, Kruskallaan 14, Bellville.
- 2214/84—**Lottering**, Margaretha Jacoba, voorheen Stighling, gebore Minnaar, 30 Mei 1925, 2505300011000, Van der Stelgebou 53, Durbanweg, Bellville, 17 Februarie 1984. Volkskastrust Bpk., Posbus 383, Pretoria.
- 3139/84—**Nelson**, Jacobus Johannes, 13/12/18, 1812135006002, Vaalheuwel, Springbok, 12/3/84. Standardtrust Bpk., Posbus 54, Kaapstad.
- 3276/84—**Myburgh**, Betsy Henrietta, 16 September 1917, 1709160045004, 11 Saltire Road, Crawford, 16 April 1984. Standardtrust Ltd, P.O. Box 54, Cape Town.
- 3157/84—**De Klerk**, Francois Nicolaas Jacobus, 17/6/12, 1206175043001, George and Annie Starck Homes, Bellville, 9/4/84. Standardtrust Ltd, P.O. Box 54, Cape Town.
- 3274/84—**Diedericks**, Richard James, 30/7/16, 1607305056013, 31 General Street, Athlone, 6/4/84; Olive Beatrice Diedericks, 20/12/20, 2012200060013. Standardtrust Ltd, P.O. Box 54, Cape Town.
- 3314/84—**Hermann**, Emil Henry, 11/7/84, 022877724W, 303 Protea Place, Culm Road, Plumstead, 2/5/84. Standardtrust Ltd, P.O. Box 54, Cape Town.
- 658/84—**Knörr**, Karolina, 6/2/12, 1202060048106, Walvis Bay, 2/9/83. Standardtrust Ltd, P.O. Box 54, Cape Town.
- 3179/84—**Shepherd**, Brian George, 6/7/26, 2607065015000, 10 Mulder Street, Riversdale, 14/4/84. Standardtrust Ltd, P.O. Box 54, Cape Town.
- 2819/84—**Molier**, Hendrik Jacobus, 9 Desember 1902, 0212095012002, Securityhuis 102, Hoofweg, Strand, 23 Maart 1984; Teuntje Molier. Standardtrust Bpk., Posbus 54, Kaapstad.
- 767/84/ASR/G—**Kempen**, Hanela Maria, 23 November 1929, 2911230057008, Tabankulu, Kommetjie Road, Fish Hoek, 20 January 1984. Lancaster & Co., P.O. Box 182, Clarendon.
- 417/84—**Havenga**, Andries Jakobus (Jacobus) Johannes, 11/12/24, 2412115039005, Van Zylstraat 37, De Aar, 14 Mei 1984. Elliott Maris Wilmans & Hay, Posbus 179, Kimberley.
- 338/84—**Smith**, Ernst Jacobus, 18 Mei 1934, 3405185073002, Draghoenerstasie, Marydale, 14 April 1984; Susanna Nancy Smith.—Standardtrust Bpk., Posbus 288, Kimberley.
- 389/84—**Pretorius**, Willem Albertus, 12 Februarie 1904, 0402125011005, Die Plaas Boskop, distrik Olifantshoek, 30 April 1984; Cornelia Petronella Pretorius, gebore Venter, 15 Mei 1906.—Duvenhage & Van der Merwe, Posbus 63, Kuruman.
- 373/84—**Jacobs**, Jacobus Petrus, 11 Oktober 1908, 0810115004006, Rivierstraat 13, Carnarvon, 15 April 1984; Martha Jacoba Jacobs, gebore Du Toit, 14 Augustus 1912, 1208140018001. Johannes G. Coetzee, Posbus 18, Carnarvon.
- 378/84—**Eden**, Dennis, 22 July 1934, 3407225071004, 14 Clifford Street, West End, Kimberley, 27 April 1984. Standardtrust Ltd, P.O. Box 288, Kimberley.
- 369/84—**Holtzhausen**, Cornelius Johannes, 20/1/27, 2701205065007, Skoustraat, Danielskuil, 23/2/84; Maria Holtzhausen, gebore Berange, 9/4/27, 2704090075008. Jan Fourie & Kie., Posbus 400, Postmasburg.
- 395/84—**Du Plessis**, Nicolaas Albertus, 27 Julie 1921, 2107275027002, Holput, De Aar, 27 Maart 1984. Volkskastrust Bpk., Posbus 602, Kimberley.
- 386/84—**Bosch**, Simon Christoffel, 1910-07-01, 1007015005006, Stellastraat 152, Vryburg, 1984-05-07; Anna Catharina Dorothea Bosch, gebore Flemming, 1922-10-29, 2210290045007. Frylink & Walker, Posbus 26, Vryburg.
- 334/84—**Ferreira**, Johannes Hendrik, 18 Januarie 1908, 0801185012003, Blesmanspost, distrik Barkly-Wes, 5 April 1984. G. F. Pieterse & O'Reilly, Posbus 82, Hartswater.
- 268/84—**Smith**, Alfred George, 23 Augustus 1918, 1808235014003, Duiufigstraat 11, Hartswater, 17 Februarie 1984; Anna Susanna Magdalena Smith, 23 Oktober 1913, 1310230012009.—Volkskastrust Bpk., Posbus 602, Kimberley.
- 326/84—**Joubert**, Hester Johanna, 28 Januarie 1923, 2301280031006, Hickstraat 7, Kimberley, 15 April 1984. Volkskastrust, Posbus 602, Kimberley.
- 392/84—**Barnard**, Cornelius Johannes, 14 Augustus 1920, 2008145003001, Tierkloof, distrik Vryburg, 24 Maart 1984.—Volkskastrust Bpk., Posbus 602, Kimberley.

OOS-KAAP • EASTERN CAPE

- 1038/84—**Coetzee**, Gert Johannes, 3/12/07, 0712035007004, Huis Van der Horst, Woonstel 15, Durbanstraat 71, Aliwal-Noord, 17/03/84; Anna Maria Coetzee, gebore Dreyer, 24/2/17, 1702240042002. Santamtrust Bpk, Posbus 1199, Port Elizabeth.

- 3021/83—**Clench**, Raymond Charles, 9 July 1902, 101194383W, 19 Upper Street, North End, Port Elizabeth, 11 September 1963; Martha Melia, also Emilia and Amelia Clench, born Lamb, 7 May 1907, 0705070036003. Goldberg & De Villiers, P.O. Box 1282, Port Elizabeth.
- 968/84—**Fouché**, Andrew John, 11 Oktober 1912, 1210115013009, Willem Olckersstraat 68, Despatch, 30 Maart 1984; Dennise Rafferty Fouché, gebore Van Logerenberg, 24 Mei 1919, 1905240010008. Conradie Campher & Kirsten, Hoofstraat 20, Despatch.
- 2417/83—**Rohden**, Maude Esther, born Webster 15 December 1912, 1212150054005, widow, 89B St George's Road, Southernwood, East London, 19 July 1983. Wilken en Van Rensburg Inc., Fourth Floor, Standard Bank Building, 77 Oxford Street, East London.
- 2810/84—**Ferreira**, Helena Charlotta, 23/10/16, 1610230020005, Opkoms, Joubertina, 30 Maart 1984; Willem Joubert Ferreira, 14/4/12, 1204145018005. Volkskastrust Bpk., Posbus 1493, Port Elizabeth.
- 1222/84—**Van Zyl**, Pieter Jacobus, 4 November 1906, 0611045030008, Camdenweg 27, Sunnyridge, Oos-Londen; Hester Anna Francina van Zyl, 1 Mei 1907, 0705010022006, Volkskastrust Bpk., Posbus 1493, Port Elizabeth.
- 10476/83—**Coetzee**, Henriette Louisa, gebore Scholtz, 1 Oktober 1937, 3710010032002, Prince Castle 1, Beckersstraat 102, Bellevue, Johannesburg, 13 Augustus 1983. Volkskastrust Bpk., Posbus 1493, Port Elizabeth.
- 1088/84—**Richardson**, Oliver Elton, 11/6/1896, 9606115010006, D6 Dunant Park, Red Cross Home, 15 Bognor Street, Summerstrand, Port Elizabeth, 16 April 1984. Fidelity Bank and Trust Company Ltd, 190 Main Street, Port Elizabeth.
- 885/84—**Nieuwoudt**, Michiel Nicolaas, 3307225068002, Aalwyn Rylaan 10, Uitenhage, 29/3/84. Boland Bank Bpk., Kerkstraat 1, Posbus 55, Uitenhage.
- 1083/84—**Thomas**, Daniel Stefanus, 20/6/10, 1006205028000, Uitenhageweg 27, Sydenham, Port Elizabeth, 20/3/84. Santamtrust Bpk., Posbus 1199, Port Elizabeth.
- 900/84—**Wait**, Sarah Jacomina Esther, 19 September 1915, 1509190025006, 22 Harrod Street, Kirkwood, 25 March 1984; Gert Ignatius van Rooyen Wait, 5 July 1911, 1107055002002. Canter & Delpont, P.O. Box 62, Kirkwood.
- 1046/84—**Masefield**, Mary Major, 12 September 1911, 94 Cecil Avenue, Bulawayo, Zimbabwe, 23 February 1984. Coopers & Lybrand, P.O. Box 660, East London.
- 1220/84—**Staples**, Grace, born Mountfort, 27 January 1895, 9501270004003, Damant Lodge, Southwell Road, Port Alfred, 21 April 1984. Brian Shelver & Champion, P.O. Box 76, Port Alfred.
- 1199/84—**Du Preez**, Jacomina Aletta, 10 Maart 1924, 2403100001001, Green Acres Village 210, Norwic Rylaan, Port Elizabeth, 23 April 1984. Volkskastrust Bpk., Posbus 1493, Port Elizabeth.
- Harrison**, Herbert Alexander, 15/5/08, 0805155009006, "Swallows Nest", P.O. Box 2120, Beacon Bay, East London, 12/5/84. Standardtrust Ltd, P.O. Box 996, East London.
- 1173/84—**Nieuwoudt**, Heremias Jacobus, 29 Julie 1910, 1007295002004, Inngslaan 31, Uitenhage, 25 Maart 1984; Hester Maria Nieuwoudt, gebore Swart, 12 Desember 1913, 1312122006005. Volkskastrust Bpk., Posbus 1493, Port Elizabeth.
- 1193/84—**Bence**, Jacob Carolus, 15 Maart 1917, 1703155028002, Whyteleaf Rylaan 272, Algoapark, Port Elizabeth, 26 April 1984; Anna Maria Bence, gebore Alberts. Volkskastrust Bpk., Posbus 1493, Port Elizabeth.
- 1146/84—**Snyman**, Joseph Benjamin, 24 Februarie 1910, 1002245008003, "Weltevrede", Uitenhage, 1 April 1984; Magdalena Jacoba Snyman, gebore Landman, 31 Julie 1914, 1146/84, Volkskastrust Bpk., Posbus 1493, Port Elizabeth.
- Sangster**, Margaret Alice, 20 January 1953, 5301200030002, Agassiz, Ugie, 15 April 1984. Standardtrust Ltd, P.O. Box 996, East London.
- 1111/84—**Lands**, Robert Stanley, 23 December 1918, 1812235020002, 10 Morningside Road, Morningside, East London, 20 April 1984; Ada Irene Lands, born Schmidt, 14 October 1924, old number 034843721. R. A. Allam, P.O. Box 239, East London.
- 522/84—**Kocovaos**, Olymbia, 27 Julie 1919, 1907270072007, Gibsonstraat 10, Uitenhage, 6 November 1983. Kitchings, Posbus 136, Uitenhage.
- 1021/84—**Sanan**, Cesar Francis, 31/7/08, 0807315029007, 60 Chamberlain Road, East London, 14/1/84. R. A. Allam, P.O. Box 239, East London.
- 521/84—**Hayward**, Frank Robert, 26 February 1935, 3502265011009, 5 Wedmore Road, Grahamstown, 14 February 1984. W. J. Olckers and Son, 127 High Street, Grahamstown.
- 894/84—**Jonker**, Carolina Wilhelmina Josefina, 4/12/26, 2612040026007, Sarel Cilliersstraat 41, Steytlerville, 26/2/84. Mnre. Steyn & Van der Vyver, Posbus 10, Willowmore.
- 1204/84—**Els**, Elizabeth Maria, 14 Junie 1928, Uniestraat, Somerset-Oos; Simon Petrus Els, 31 Julie 1933, 3307315025003. Volkskastrust Bpk., Posbus 1493, Port Elizabeth.
- Grobler**, Maria Louisa Cook, gebore Haarhof, 17 Oktober 1917, plaas Fairbairn, distrik Maclear, 27 April 1984. Standardtrust Bpk., Posbus 996, Oos-Londen.
- Pauls**, Sarah Johanna, born Frost, 19 January 1927, 2701190040007, 31 Bunting Crescent, Cotswold Extension, Port Elizabeth, 22 May 1984. Burman, Katz, Saks & Butler, P.O. Box 3220, Port Elizabeth.
- 974/84—**Vorster**, Jacobus Munro, 6/3/15, 1503065016000, Cullean, Thomas River, 7 February 1984; Emmarentia Aletta Vorster, 24/2/26, 2602240024001. Santamtrust Bpk., Posbus 1199, Port Elizabeth.
- 1077/84—**Finch**, George Harold, 16/3/16, 1603165054008, Woonstel 3, Echovale, Aragonweg, Port Elizabeth, 24/3/84. Santamtrust Bpk., Posbus 1199, Port Elizabeth.
- 1128/84—**Michau**, Johanna De Villiers, gebore Nortje, 9 November 1936, 3611090004004, Kollegeweg 1, Cradock, 6 April 1984. Santamtrust Bpk., Posbus 1199, Port Elizabeth.
- 1079/84—**Lemley**, John Nell, 8/3/28, 2803085029002, Alfonsostraat 21, Uitenhage, 8/4/84. Santamtrust Bpk., Posbus 1199, Port Elizabeth.
- Goldschmidt**, Alfred Kingon, 30 December 1918, 1812305009000, 58 Griffin Road, Cambridge West, East London, 22 April 1984. Standardtrust Ltd, P.O. Box 996, East London.
- 3554/83—**Chambers**, Stanislaus Eugene, 4 May 1915, 1505045031009, 20 Accacia Street, Cradock, 13 Oktober 1983; Servita Chambers, -/-/15. Miles & Moorhead, 2101 Durban Bay House, 333 Smith Street, Durban.
- 1247/84—**Spence**, Myrtle Mary, formerly Pitt, born Stone, 16 April 1902, 0204160012009, widow, 43 Papenkuils Street, Westering, Port Elizabeth, 4 May 1984. Oosthuizen, Hazell & Wilmot, P.O. Box 1125, Port Elizabeth.
- Steel**, Elspeth Catherine, 26/2/04, 0402260001001, The Manor, St George's Road, Southernwood, East London, 17/5/84. Barclays National Bank Ltd, P.O. Box 1537, East London.
- Le Roes**, Adriana Alberta, voorheen Uys, ook bekend as Uijs, gebore Veldtman, 30/10/03, 0310300025007, Keeromstraat 3, Robertson, 23/4/84. Barclays-Nasionale Bank Bpk., Posbus 1537, Oos-Londen.
- Le Roux**, Alvina Auguste Wilhelmina, born Nass, 25/8/02, 0208250002002, 17 Kommissaris Road, Sydenham, Port Elizabeth, 7/5/84. Barclays Nasionale Bank Ltd, P.O. Box 1537, East London.
- Allen**, John Henry, 8/11/05, 0511085020002, Cottage 2, Fairlands Home for the Aged, Wavell Avenue, Cambridge West, East London, 16/5/84; Mary Kate Allen, born O'Leary, also known as Kathleen Allen, 29/6/08, 0806290021104. Barclays National Bank Ltd, P.O. Box 1537, East London.
- Benneyworth**, Albert Denis, 29/8/28, 2808295018109, 31 Bonza Bay Road, Beacon Bay, East London, 5/5/84. Barclays National Bank Ltd, P.O. Box 1537, East London.
- 990/84—**Lalor**, George, 7/9/13, 1309075022008, 44 Albany Street, East London, 31 March 1984. J. A. Yazbek & Co., P.O. Box 577, East London.
- 1169/84—**Jonker**, Gabriel Jakobus, 6 Oktober 1917, 1710065039003, Uitenhageweg 23, Sydenham, Port Elizabeth, 22 April 1984; Sarah Johanna Jonker, gebore McLeod, 24 November 1918, 1811240030006. Delpont & Delpont, Posbus 3125, Port Elizabeth.
- 1212/84—**Derman**, Eunice Lilian, 13 July 1907, 0707130025000, 36 Grey Street, King William's Town, 30 April 1984. Squire Smith & Laurie, P.O. Box 511, King William's Town.
- 1150/84—**Hewson**, Stella Agnes, 6 May 1909, 0905060035003, 5 Morrison Street, Glendinningvale, Port Elizabeth, 19 April 1984. Standardtrust Ltd, P.O. Box 329, Port Elizabeth.

- 1230/84—Meier, Ernest Theodore, 20 March 1903, 0303205008004, Room 37, Manor House, St George's Road, East London, 18 April 1984. The Bax Partnership, P.O. Box 102, East London.
- 1054/84—Davies, Roger Barncastle, 6/12/35, 3512065032006, 20 Young Road, Mill Park, Port Elizabeth, 11/4/84. Syferts Trust Ltd, P.O. Box 466, Port Elizabeth.
- 1030/84—McGillewie, Henrietta Maria, born Wium, 29/12/1896, 9612290008005, The Manor Hotel, St George's Road, Southernwood, East London, 1/4/84. Syferts Trust Ltd, P.O. Box 447, East London.
- 1136/84—Owen, Henry James, 16 April 1921, 2104165046101, 62a Worraker Street, Newton Park, Port Elizabeth, 26 April 1984. Barclays Nasional Bank Ltd, P.O. Box 164, Port Elizabeth.
- 1232/84—Nell, Theunis Stefanus Johannes, 27 September 1906, 0609275020004, Petersonlaan 2, Sentraal, Port Elizabeth, 30 April 1984. Volkskastrust Bpk., Posbus 1493, Port Elizabeth.
- 1217/84—Rowland, Kingsley Norton, 29/7/02, 0207295001003, Christmasvale, P.O. Kidds Beach, East London, 14/4/84. Syferts Trust Ltd, P.O. Box 447, East London.

NATAL

- 856/84—Visagie, Johannes Petrus, 30/12/1894, 9412305004002, Schaapkopje, distrik Vryheid, 13/1/84; Anna Maria Petronella Visagie, gebore Potgieter, 14/7/01, 0107140023006. Hannah, Schoombée & Steyn, Posbus 34, Vryheid.
- 1693/83—Nxumalo, Mandlakayise Bennett, -/21, 101931007, Burford, Ladysmith, 13 November 1982. Frans Terblanche & Company, P.O. Box 331, Bergville.
- 1707/84—Wichura, Michael Alfred, 30 June 1914, 211696410W, 25 Kirstenbosch, Sandown Road, Snell Parade, Durban, 15 March 1984. S. B. de Klerk, 4 Innes Avenue, Bloemfontein.
- Wallace, Gertina Maria Elizabeth, 19/11/03, 244001002W, 18 Kruger Street, Paulpietersburg, 6/4/84. Barclays National Bank Ltd, P.O. Box 381, Pietermaritzburg.
- 2225/84—Hegy, Pauline Maxfield, 4/11/1891, USA Citizen, Orchard Lee Nursing Home, Durban, 9/2/84. Berkowitz Kirkel Cohen Inc., 15th Floor, Durban Bay House, 333 Smith Street, Durban.
- 1444/84—Kennedy, Sheelagh Gillian Elizabeth, 21 March 1942, 4203210005001, Cheshire Homes, 890 Main Road, Moseley, Queensburgh, 1 March 1984. Garlicke & Bousfield Inc., 10th Floor, Standard House, 275 Smith Street, Durban.
- 1715/83—Peycke, Marjorie, 29 March 1900, 902513772W, 171 North Ridge Road, Durban, 22 November 1975. Mooney, Ford & Partners, 15 Hermitage Street, Durban.
- 1368/84—Johns, Antonia Theresa Sandra, 22/2/26, 2602220053053, 22 Ridgcroft Drive, Longcroft, Phoenix, 17/6/83; Leslie Anthony Johns, 30 August 1930, 3008305094054. R. Manilal & Company, Suite 63, Phoenix Centre, 3341 North Coast Road, Mount Edgecombe.
- 2666/84—Stephen, Russell Duncan, 18/1/15, 1501185038003, 301 Villa Pax, Umhlanga Rocks, 10/5/84. Rand Natal Trust Co. Ltd, 26 Fenton Road, Durban.
- 2568/84—Mawrey, Stanley, 23 March 1905, 0503235035105, 51 Pomona Gardens, McMillan Road, Hillcrest, 29 April 1984. Lester Hall Ewing & Swan, P.O. Box 52, Hillcrest.
- 1194/84—Panjalama, 24/11/31, 800466901A, House 11, Road 229, Bayview, Chatsworth, 7/11/83; Rajmanikum Pillay. Krishna Pillay, House 11, Road 229, Bayview, Chatsworth.
- 1821/84—Chengiah, Siva Dass, 30/12/35, 800447741A, 55 Saffron Hill, Havenside, Chatsworth, 28/12/83; Seethamma Chengiah, 15/5/37. Nat Chellakooty & Co., P.O. Box 45213, Chatsglen.
- 753/84—Pollecoff, Fanny, 17 January 1897, Estepona, Spain, 11 January 1983. Ditz Incorporated, 50 Masonic Grove, Durban.
- 1751/84—Francis, Mario Samuel, 6 July 1925, 2507065066054, 3 The Knoll, Kenville, Durban, 10 March 1984; Govindamma, 15 August 1938, 3808150084054. Kiran Desai & Company, 60/61 CNR House, 22 Cross Street, Durban.
- 1543/84—Cerff, John Ferdinand, 17/10/13, 1310175046004, 67 Bencorrum, Prince Street, Durban, 4/3/84; Gezina Cerff, 23/1/24, 2401230082008. Garlicke & Bousfield Inc., 11th Floor, Standard House, 275 Smith Street, Durban.
- 1265/84—Glaister, Desmond John, 21/5/35, 3505215024006, Pinmore Farm, Thornville, 20/2/84. J. Leslie Smith & Co., P.O. Box 297, Pietermaritzburg.
- 1671/84—Pillay, Madurai, 2/10/45, 4510025132055, Road 7, House 597, Malagassy, Durban, 10 August 1983; Beena Pillay, 19 April 1959, 5904190027050. S. Nadasen & Company, P.O. Box 45274, Chatsglen.
- 2181/84—Shaik Abdoool Gonee, Ramjan, 13 December 1906, 0612135030056, 236 Silverglen Drive, Silverglen, 3 February 1984; Sarah Bee Shaik Abdoool Gonee, 26 January 1918, 1801260050059. Marriott & Brodie, P.O. Box 1465, Durban.
- 1747/84—Kanerva, Erik Osmo, 11 May 1917, Vaasa, Finland, 28 January 1981. E. R. Browne & Sons, 1403 Maritime House, Salmon Grove, Durban.
- 7075/83—Hodgson, Melvyn Raynor, 5 June 1934, 3406055034009, 199 Blair Atholl Road, Westville, 3 December 1983; Priscilla Kathleen Hodgson, 6 April 1941, 4104060031008. Bernstein & Gifford, P.O. Box 3999, Durban.
- 1804/84—Whittaker, Fred, 14/11/19, 1911145033004, 1601 Sanlam Park, Beach Road, Amanzimtoti, 14/3/84; Irene Whittaker, 24/9/21, 2109240023009. Browne Brodie & Co., 12th Floor, United Building, 291 Smith Street, Durban.
- 2344/84—Moxham, Kenneth Sydney, 25/5/1895, 9505255003005, Driefontein, Kokstad, 25 March 1984. Standardtrust Ltd, P.O. Box 2743, Durban.
- 2342/84—Holland, Rodney Francis John, 6/8/22, 2208065035005, 34 Clair Avenue, Manor Gardens, South Ridge Road, Durban, 13/4/84. Standardtrust Ltd, P.O. Box 2743, Durban.
- 2340/84—Elliott, Jack, 20/9/05, 0509205024003, Blue Waters Hotel, Snell Parade, Durban, 19 April 1984. Standardtrust Ltd, P.O. Box 2743, Durban.
- 2437/84—Lawson, Muriel Elizabeth, 8 March 1908, 0803080001008, Village of Happiness, Margate, 12 April 1984. Standardtrust Ltd, ABC Chambers, 66 Field Street, Durban.
- 2293/84—Norkie, John Ernest, 17/10/22, 211448554C, 83 Beaunoir Avenue, Wentworth, Durban, 16/3/84; Daisy Norkie, 23 June 1928, 007670801C. Thorpe & Hands, Suite 2522, 320 West Street, Durban.
- 7026/83—Barkath, Yunus, 3/9/38, 3809035038059, Road 1129, House 20, Chatsworth, Durban, 5/8/83; Hawa Barkath, 13/1/39, 800387890A: Farouk Vahed & Company, P.O. Box 1187, Durban.
- 2123/84—Rachmann, Audrey Irene, 17 July 1931, 3107170038004, 807 Main Road, Moseley, Escombe, 28 March 1984. N. Gerber, P.O. Box 1462, Durban.
- 2438/84—Lesage, Marie Francois Jean, 7/4/28, 2804075016108, 15 Kingston Flats, 35 Park Street, Durban, 22/4/84; Marguerite Marise Lesage, 10/6/39, 3906100001101. Standardtrust Ltd, P.O. Box 2743, Durban.
- 2062/84—Lindsay, Doreen Selina Ellen, 7/11/12, 1211070034006, Andover Nursing Home, 73 Chelmsford Road, Durban, 5 April 1984. Standardtrust Ltd, P.O. Box 2743, Durban.
- 2535/84—De Graaf, Robina Martin, 7/12/1888, 8812070005004, Villa Assumpta, Convalescent Home, 55 Tanner Road, Pietermaritzburg, 29 April 1984. Shepstone & Wylie, P.O. Box 1297, Pietermaritzburg.
- 79/84—Zulu, Miriam Adelaide, 3/2/06, 536011783, Smeroe, P.O. Edendale, 19/11/83. J. Leslie Smith & Co., P.O. Box 297, Pietermaritzburg.
- 2419/84—Dicks, George Uriah, 11 March 1941, 4103115027003, 20 Haynes Road, Bisley, Pietermaritzburg, 6 April 1984; Hester Dorathea Dicks. Standardtrust Ltd, P.O. Box 917, Pietermaritzburg.
- 2659/84—Aizlewood, John Noel Peter, 14 July 1928, 2807145037103, 3 Church Lane, Hilton, 9 April 1984. Standardtrust Ltd, P.O. Box 917, Pietermaritzburg.

- 2433/84—Wynne, William Aubrey Bryan, 23/8/35, 3508235019006, Overlyn, P.O. Box 1, Eshowe, 23/4/84. Gesina Johanna Wynne, P.O. Box 1, Eshowe.
- 2537/84—Hoosen, Ismail, 12/6/41, 4106125056052, 18 Park Street, Glencoe, 15 April 1984; Kathoon Hoosen, 12/9/45, 4509120097056. Rafiq Khan & Co., P.O. Box 692, Dundee.
- 2492/84—Mennen, Hans, 7 April 1904, 0404075029003, 8 Percy Sperryn Drive, Estcourt, 15 April 1984. Borman, Snyman & Barnard, Rentmeester Building, 63 Voortrekker Road, Potgietersrus.
- 2565/84—De Maleingreau D'Hembise, Jean Leon Octave Ghislain, 11/9/1895, 9509115006109, Lyndhurst, Estcourt, 26 April 1984. Lombard, Kitschoff & Jooste, 81b Harding Street, P.O. Box 18, Estcourt.
- 3173/70—Beachen, Sookdai, 800487136A, Main Road, Ixopo, 13 September 1968. Mason Buchan Leslie Weinberg & Co., P.O. Box 100, Pietermaritzburg.
- 2411/84—Naidoo, Mariamma, 5/9/35, 3509050089058, Third Street, Park Rynie, 7/4/84; Nyna Francis Naidoo, 23/12/27, 2712235064050. Blamey & Ferguson, 138 Scott Street, Scottburgh.
- 2427/84—Read, Harold Frederick, 30/8/15, 1508305002009, Flat 30, Scottburgh Centre, Scott Street, Scottburgh, 21/4/84; Catherine Read, née Henning, 22/6/16, 1606220022001. Blamey & Ferguson, 138 Scott Street, Scottburgh.
- 4574/83—Balie, Michael Frederick, 14/1/27, Sparksweg 389, Sydenham, Durban, 6 Julie 1983. D. P. de Klerk & Van Gend, Posbus 1857, Kaapstad.
- 2556/84—Parbathy, 1/1/21, 800305751A, 83 Belmont Road, Red Hill, Durban, 20 February 1983; Rampersad Rampiara Maharaj, 22 February 1918, 1802225038056. A. Christopher & Co., First Floor, 140 Queen Street, Durban.
- 2493/84—Minnaar, Philippina Petronella, 3 Maart 1915, 1503030017000, Sedgwicklaan 862, Hibberdene, 21 April 1984. P. R. Dreyer & Kie., Posbus 62, Estcourt.
- 2368/84—Cass, Maurice Garland, 15/10/07, 0710155004009, 12 Jooste Street, Utrecht, 18/4/84. Barclays National Bank Ltd, P.O. Box 381, Pietermaritzburg.
- 6516/83—Mallanna, Yenkia, 20/12/51, 5112205043050, 29 Bengal Road, Ladysmith, 8 October 1983; Cynthia Hilary Edith Mallanna, 21 July 1954, 5407210070019. Macaulay & Riddell, P.O. Box 107, Ladysmith.
- 2392/84—Kok, Cornelia Margrieta, 9 May 1910, 1005090025006, Flat 1, Beauvais, 56 College Road, Pietermaritzburg, 26 April 1984. Bale Greene & Morcom, P.O. Box 126, Pietermaritzburg.
- 1313/84—Fuller, Cora Lottie, 23 October 1890, Westhaven Nursing Home, District of Claridge, Pietermaritzburg, 12 February 1984. Bale Greene & Morcom, P.O. Box 126, Pietermaritzburg.
- 663/84—König, Franz Richard Ferdinand, 10 July 1906, 0607105016002, 103 Cordoba, Marine Drive, Umhlanga Rocks, 10 November 1983; Dorothy Elizabeth König, 3 April 1912, 1204030018102. Gavin Gow & Co., P.O. Box 610, Umhlanga Rocks.
- 2483/84—Vanmali, Chandrakant Thakor, 1/1/47, 800345948A, 21 35th Avenue, Umhlatuzana Township, Durban, 21/3/84. c/o Krish Govender & Company, 131/3 Goodhope Centre, 92 Queen Street, Durban.
- 2601/84—Dorrofield, Evelyn Hilda Louise, 28 January 1907, 0701280035000, 2 Hanston, 18/20 Bonieux Place, Durban, 26 April 1984. AMC de Jager, 302 Denor House, 356 Smith Street, Durban.
- 2420/84—Fielding, Margaret, 24 June 1925, 2506240050009, 7 Tivendale Road, Cowies Hill, 8 April 1984. Arthur Young & Company, P.O. Box 859, Durban.
- 826/84—Sukhdeo, Ramruthen, 12 August 1930, 3008125067058, 17 Venus Lane, Woodhurst, Chatsworth, 24 December 1983; Kamaladevi Ramruthen, 25 January 1938, 3801250056056. Raj Bodasing, M. A. Singh & Company, 177 Grey Street, Durban.
- 2476/84—Moodley, Ramalinga (Ramlinga), 15 July 1921, 800425835A, 78 Drewstead Road, Reservoir Hills, 23 October 1983; Lutchmi Moodley, 3/06/29. Seedat, Pillay & Govindasamy, Suite 1501, 15th Floor, Permanent Corner, 102 Field Street, Durban.
- 2463/84—Wulff, Jessie Winifred, 16/11/19, 1911160056005, 8 Homepark, Charles Henwood Avenue, Durban, 14/4/84. Syfretstrust Ltd, P.O. Box 135, Durban.
- 1952/84—Grange, William Robert James, 16/11/05, 0511165035102, 77 Benjamin Road, Fynnlands, Bluff, 24/3/84. Syfrets Trust Ltd, P.O. Box 135, Durban.
- 2212/84—Conrad, Stefan Henryk, 20/7/56, 5607205128009, 35 Belvedere Court, Cato Road, Durban. 30/3/84. Shepstone & Wylie, P.O. Box 205, Durban.
- 2616/84—Naidoo, Perumal (Ramsamy Perumal Naidoo), 22/06/01, 800397711A, 12 Granada Street, Shallcross, 19/8/82. Strini Bangaar, Suite 1204, Teachers Centre, 113 Albert Street.
- 3451/83—Wagget, Henry, 14/12/33, 331412780W, 7 Woodlands Drive, Durban, 26/6/83. Helman & Partners, P. O. Box 4091, Durban.
- 2595/84—Cramb, Clive Dugdale Boscawen, 20 March 1915, 1503205015003, 10 Iolanthe, 60 Halford Road, Durban, 3 April 1984. Allaway Shepstone, P.O. Box 513, Durban.
- 2621/84—Tyler, Ivy Irene, 1905-07-22, 0507220027001, 4 Ryde Place, Durban North, 1984-05-02. Syfrets Trust Ltd, P.O. Box 135, Durban.
- 2107/84—Eaton, Benjamin D'Urban, 27/7/07, 0707215023003, Golden Banana Ranch, P.O. Munster, 15/3/84. Barclays National Bank Ltd, P.O. Box 3409, Durban.
- 1836/84—Samuel, Johannes Jacobus Samuel, 2/6/10, 1006025002003, Flat 65 Sunnands, Doonside, 7/3/84; Anna Susanna Samuel, 3/8/12, 1208030017006. Barclays National Bank Ltd., P.O. Box 3409, Durban.
- 2413/84—Mackessack, Malcolm Charles, 19/1/24, 2401195049000, 71 Sealodge, Lagoon Drive, Umhlanga Rocks, 22/4/84; Elfrieda Beatrice Mackessack, 25/4/17, 1704250039001. Barclays National Bank Ltd, P.O. Box 3409, Durban.
- 2224/84—Giri, Joseph Carlo, 4/6/1891, 248029180W, Hibiscus House, Village of Happiness, Margate, 28/3/84; Dorothy Mary Giri, 248029181. Barclays National Bank Ltd, P.O. Box 3409, Durban.
- 1688/83—Van Rooyen, Helena Anna Maria, voorheen Simpson, Penderis, Havemann, gebore Rabie, 19/8/18, 1808190053004, Huis 26, Hlobane, Vryheid, 21/2/83. Santamtrust Bpk., Posbus 2174, Durban.
- 1325/84—Du Plooy, Abraham, 17/3/10, 1003175046005, 9 Allen Place, Pennington, 14/2/84; Magdalena Maria du Plooy, 23/8/16, 1608230036005. Santamtrust Bpk., Posbus 2174, Durban.
- 1324/84—Du Plooy, Anna Maria, 27/5/21, 2105270002004, 4 Murleigh, 390 Moore Road, Durban, 13/2/84; Stephen du Plooy, 12/11/21, 2111125002004. Santamtrust Bpk., Posbus 2174, Durban.
- 611/84—Van Graan, Neville Edward, 1/10/38, 3810015004004, 39 Aquilea Avenue, Saicor Village, Umkomaas, 6/1/84; Merle Dilys Avril van Graan, 1/10/38, 4804010003003. Santamtrust Bpk., Posbus 2174, Durban.
- 2625/84—Wagner, Charles Leonard, 13/12/06, 0612135004002, 1708 Sanlampark, Amanzimtoti, 23/4/84. Barclays National Bank Ltd, P.O. Box 3409, Durban.
- 1682/84—Edries, Haroun, 30 October 1936, 3610305073028, 1047 North Coast Road, Redhill, Durban, 8 March 1984; Farida Naidoo Edries, 12 March 1950, 5004120152050. Farida Naidoo Edries, P.O. Box 2041, Durban.
- 2455/84—Kemp, Wilfred William John, 6/6/13, 1306065035008, 228 Glen Road, Montclair, Durban, 14/4/84. Barclays National Bank Ltd, P.O. Box 3409, Durban.
- 1790/84—Fourie, Ernst Leopold, 22/10/48, 4810225039005, 22 Maroelamoot, Arbotteum, Richardsbay, 6/3/84; Martha Maria Fourie, 28/6/53, 5306280104007. Santamtrust Bpk., Posbus 2174, Durban.
- 2514/84—Jonck, Lodewyk Marthinus, 5/11/44, 4411055025006, 65 Shepstone Road, Ladysmith, 26/3/84; Susara Maryna Jonck, 29/10/47, 4710290074004. Santamtrust Bpk., Posbus 2174, Durban.
- 1852/84—Moorgas, Harold Eric, 18/3/33, 3303185072050, 75 Fosdale Road, Briardene, Newlands West, Durban, 11/3/84; Georgina Maureen, 18/10/36, 3610190055056. Santamtrust Ltd, P.O. Box 2174, Durban.

- 2624/84—**Woest**, William Richard, 5/2/23, 2302055011009, 11 South Street, Park Rynie, 21/4/84, Gloria Eunice Woest, born Jefferey, 28/6/23, 2306280036004. Santamtrust Ltd, P.O. Box 2174, Durban.
- 2509/84—**Blowey**, Miriam, 8/11/1893, 9811080009005, 67 Stirling Court, 163 Smith Street, Durban, 19/4/84. Barclays National Bank Ltd, P.O. Box 3409, Durban.
- 16/84—**Opperman**, Martha Elizabeth Alletta, 18 February 1956, 5602180131003, 116 Sub Nigel, Nigel, Wagon Wheels, Caravan Park, Empangeni, 3 November 1983. Barclays National Bank Ltd, P.O. Box 2036, Johannesburg.
- 5909/82—**Lund-Jackson**, Brian Geoffrey, 4 Maart 1945, 4503045047007, 6 Jacaranda Street, Empangeni, 1 Oktober 1982. Snijman, Smullen & Theo Rood, Posbus 38, Vereeniging.

ORANJE-VRYSTAAT • ORANGE FREE STATE

- 507/84—**Bender**, Stephanus Johannes, 9/8/24, 2408095009000, Parys, 20/2/84; Catharina Aletta Elizabeth Bender. Barclays-Nasionale Bank Bpk., Posbus 1714, Bloemfontein.
- 739/84—**Du Plessis**, Louisa Hendrina Maria Magdalena, gebore Van Zyl, 3/11/09, 0911030013005, Oosstraat 3, Bethulie, 29/3/84; Petrus Jacob du Plessis, 0712035008002. Barclays-Nasionale Bank Bpk., Posbus 1714, Bloemfontein.
- 919/84—**Francis**, Winifred May, 17/12/1891, 911217003002, Siesta Old Age Home, Bloemfontein, 2/5/84. Barclays-Nasionale Bank Bpk., Posbus 1714, Bloemfontein.
- 498/84—**Froneman**, Judeth Janetha, 25/2/08, 0802250014007, Siestatehuis vir Bejaardes, Bloemfontein, 9/2/84. Barclays-Nasionale Bank Bpk., Posbus 1714, Bloemfontein.
- 836/84—**Meyer**, Jacobus Johannes Oosthuizen, 15/11/04, 0411155001000, Kroonstad, 16/4/84. Barclays-Nasionale Bank Bpk., Posbus 1714, Bloemfontein.
- 963/84—**Rautenbach**, Catharina Helena, 19/7/11, 1107190013005, Van Rooylaan 10, Universitas, Bloemfontein, 6/5/84. Barclays-Nasionale Bank Bpk., Posbus 1714, Bloemfontein.
- 885/84—**Labuschagne**, Michiel Andries, 6 Augustus 1949, 4908065704002, Steyn Delpportstraat 19, Bethlehem, 14 Maart 1984. Volkskastrust Bpk., Posbus 323, Bloemfontein.
- 585/84—**Van der Walt**, Sarel David, 18 Desember 1907, 0712185022001, Van der Stelstraat 5, Welkom, 11 Februarie 1984; Ammentia Aletta Maria van der Walt, gebore Boshoff, 22 Februarie 1915, 1502220009009. Volkskastrust Bpk., Posbus 323, Bloemfontein.
- 2060/83—**Maartens**, Jan Lodewyk, 26 Mei 1918, 1805265011008, Spitskop, distrik Reddersburg, 8 September 1983. J. P. Daffue, vir Van Deventer, Daffue & Maree, Posbus 1989, Bloemfontein.
- 954/84—**Schabert**, Jacobus Nicolaas Boshoff, 9 Junie 1897, 9706095001007, Luytstraat 7, Frankfort, 26 April 1984. E. J. P. Smit, Posbus 514, Bethlehem.
- 953/84—**Kaplen**, Mary, 29 Januarie 1917, 1701290030008, Wistariawoonstelle 24, Aliwalstraat, Bloemfontein, 6 Mei 1984. E. K. Kaplen, p/a J. G. Kriek & Cloete, Posbus 299, Bloemfontein.
- 802/84—**Perez**, Giuseppe Turiddo Emilio, 19/9/14, 331214099W, 29 Exton Road, Bloemfontein, 18/4/84. L. N. Sackstein, c/o Israel & Sackstein, P.O. Box 256, Bloemfontein, 21 days.
- 339/84—**Eave**, Alan Goerge, 22 Januarie 1962, 6201225001001, St Helena Goudmyne, distrik Welkom, 29 Januarie 1984. De Wet & Van Niekerk, Posbus 630, Dundee.
- 923/84—**Kleynhans**, Louis Jacobus, 14/12/10, 1012145025007, Rietfontein, distrik Brandfort, 1 Mei 1984; Gertruida Christina Kleynhans, gebore Eager, 30 Maart 1911, 1103300034007. Hill, McHardy & Herbst, Posbus 93, Bloemfontein.
- 875/84—**Miller**, Moses, 4/9/13, 1309045012006, 504 Albany Court, Alexandra Avenue, Bloemfontein, 4 April 1984. H. J. F. Steyn, P.O. Box 819, Bloemfontein.
- 949/84—**Louw**, Pieter Jacobus, 2 Februarie 1912, 1202025016008, Swartkoppies, Jagersfontein, 16 April 1984. Naudes, Posbus 153, Bloemfontein.
- 823/84—**Botha**, Martha Maria, gebore Hugo, 4 April 1905, 0504040014004, Mooi Hawe, Bloemfontein, 4 April 1984. Hugo & Terblanche, Posbus 14, Petrusburg.
- 580/84—**De la Harpe**, Jan van Reenen, 23 Oktober 1915, 1510235018006, Casa Mia 3, President Burgerstraat, Bethlehem, 3 Maart 1984. E. G. Cooper & Seuns, Posbus 27, Bloemfontein.
- 901/84—**Botha**, Louis, 21 Junie 1920, 2006215012001, Draaihoogte, Posbus 346, Vrede, 27 April 1984; Susara Elizabeth Botha, gebore Venter, 3 Augustus 1926, 2608030016008. Theron & Neethling, Posbus 50, Memel.
- 910/84—**Fouche**, Joyce Elizabeth, 12 September 1922, 2209120005009, 50 Fisher Street, Dagbreek, Welkom, 1 April 1984. Webber & Newdigate, P.O. Box 501, Bloemfontein.
- 784/84—**Cronjé**, Albertus Stefanus, 3 Augustus 1916, 1608035013001, Uniestraat 24b, Parys, 29 Maart 1984; Carolina Augusta Martina Cronjé, gebore Jordaan, 27 Junie 1923, 2306270040008. Vorster & Coetzee, Posbus 5, Parys.
- 903/84—**Louw**, George Homo, 15 Julie 1924, 2407155020006, Express, Pk. Villiers, 22 April 1924. Van der Merwe, Claasen & Louw, Posbus 7, Frankfort.
- 748/84—**Claassen**, Johanna Elizabeth, gebore Dannhauser, 28/11/08, 0811280040007, Oorvloedfontein, Heilbron, 29 Maart 1984; Salomon Claassen, 21 Junie 1909, 0906215015007. Cornelius & Wilsnach, Posbus 205, Heilbron.
- 950/84—**Jacobs**, Daniel, 18/4/62, 6204185008002, Steynstraat, Viljoenskroon, 30/4/84. J. D. G. Oberholster, Posbus 47, Bloemhof.
- 864/84—**Roussouw**, Martha Jacoba Susanna, 16 April 1905, 0504160003001, Luciastraat 16, Riebeeckstad, Welkom. Volkskastrust Bpk., Posbus 61488, Marshalltown.
- 955/84—**Jooste**, Gerrit Hendrik, 2/2/20, 2002025011002, Parfittlaan 69, Bloemfontein, 27/4/84; Huibrecht Catharina Jooste. Standardtrust Bpk., Posbus 1248, Bloemfontein.
- 956/84—**Van der Westhuizen**, Benjamin, 22/2/12, 1202225029009, Eeufeesweg 19, Bayswater, Bloemfontein, 4/5/84; Joey Noline van der Westhuizen. Standardtrust Bpk., Posbus 1248, Bloemfontein.
- 867/84—**Theron**, Judith Margaretha, 26/11/04, 0411260015002, Matonshoek, Marquard, 16 April 1984. Standardtrust Bpk., Posbus 1248, Bloemfontein.
- 925/84—**Simes**, Mirjam, 21 Augustus 1903, 0308210011000, Bruwerstraat 63, Vrede, 14 April 1984. Standardtrust Bpk., Posbus 1248, Bloemfontein.
- 862/84—**Lombaard**, Nico Adriaan, 4/9/64, 6409045073001, Wilcocksweg 63, Bloemfontein, 23/4/84. Standardtrust Bpk., Posbus 1248, Bloemfontein.
- 924/84—**Scott**, George Pellissier, 24/11/04, 0411245009005, Rudolphgebou 1, Waterkantstraat, Odendaalsrus, 17/4/84. Standardtrust Bpk., Posbus 1248, Bloemfontein.
- 922/84—**Hugo**, Nicolaas Johannes, 27 Mei 1906, 0605275020002, Vanstadensrus, 23 April 1984. Standardtrust Bpk., Posbus 1248, Bloemfontein.
- 912/84—**Odendaal**, Christina Susanna, 14 Junie 1903, 0306140020000, Avondvrede-ouetehuis, Vrede, 13 April 1984. Standardtrust Bpk., Posbus 1248, Bloemfontein.
- 768/84—**Du Plessis**, Anna Elizabeth, 19 September 1910, 1009190001008, Kerkstraat 15, Ventersburg, 22 Maart 1984. Johan Wilhelm Sonnekus, vir Santamtrust Bpk., Posbus 2413, Bloemfontein.
- 710/84—**Crafford**, Dirk Johannes, 9 Mei 1920, 2005095015001, Derde Laan 21, Dagbreek, Hennenman, 9 Maart 1984; Victoria Judith Dorothea Crafford, 16 Oktober 1919, 1901160023006. Johan Wilhelm Sonnekus, vir Santamtrust Bpk., Posbus 2413, Bloemfontein.
- 961/84—**Hattingh**, Mathys Cornelius, 20 Februarie 1922, 2202205032006, Five Wayswoonstelle 11, Bloemfontein, 23 April 1984. Johan Wilhelm Sonnekus, vir Santamtrust Bpk., Posbus 2413, Bloemfontein.

- 600/84—**Joubert**, Gertruida Susanna, gebore Roos, 14 Julie 1906, 0607140004005, Baxterstraat 16, Bethlehem, 15 Februarie 1984; Sarel Petrus Francois Joubert, 4 Junie 1896, 960604509003, André Hugo, Posbus 153, Bethlehem.
- 270/84—**Killian**, Hendrik Johannes, 14 Julie 1952, 5207145115008, Huis 2, SA Vervoerdienste, Senekal, 22 Januarie 1984. J. A. Scorgie & Kie., Posbus 50, Marquard.
- 827/84—**Volker**, Dieter Jurgen, 22/6/55, 5506225069005, 153 Koedoe Street, Bloemfontein, 26/3/84. Barclays National Bank Ltd, P.O. Box 3409, Durban.

Vorm/Form J 187

**LIKWIDASIE- EN DISTRIBUSIEREKENINGS IN BESTORWE BOEDELS
WAT TER INSAE LÊ**

Ingevolge artikel 35 (5) van Wet 66 van 1965, word hierby kennis gegee dat duplikate van die likwidasië- en distribusierekenings (eerste en finale, *tensy anders vermeld*) in die boedels hieronder vermeld, in die kantore van die Meesters en Landdroste soos vermeld en gedurende 'n tydperk van 21 dae (of korter of langer *indien spesiaal vermeld*) vanaf gemelde datums of vanaf datum van publikasie hiervan, as dit later is, ter insae lê van alle persone wat daarby belang het.

Indien binne genoemde tydperk geen besware daarteen by die betrokke Meesters ingedien word nie, gaan die eksekuteurs oor tot die uitbetalings ingevolge gemelde rekenings.

Die inligting word soos volg verstrek: Boedelnummer, familienaam, voornaam(name), persoonsnummer, laaste adres, beskrywing van rekening as dit anders as eerste en finale is; indien oorledene in gemeenskap van goedere getroud was die nagelate eggenoot(note) se name, familienaam en persoonsnummer; tydperk van insae (indien korter of langer as 21 dae), Landdroskantoor.

**LIQUIDATION AND DISTRIBUTION ACCOUNTS IN DECEASED ESTATES
LYING FOR INSPECTION**

In terms of section 35 (5) of Act 66 of 1965, notice is hereby given that copies of the liquidation and distribution accounts (first and final, *unless otherwise stated*) in the estates specified below will be open for the inspection of all persons interested therein for a period of 21 days (or shorter or longer *if specially stated*) from the date specified or from the date of publication hereof, whichever may be the later, and at the offices of the Masters and Magistrates as stated.

Should no objection thereto be lodged with the Masters concerned during the specified period, the executors will proceed to make payments in accordance with the accounts.

The information is given in the following order: Estate number, surname, christian name(s), identity number, last address, description of account other than first and final; if deceased was married in community of property the surviving spouse's names, surname and identity number; period of inspection (if shorter or longer than 21 days), Magistrate's Office.

TRANSVAAL

By die kantoor van die Meester, PRETORIA, en ook van die landdroos van die distrik wanneer dit tussen hakies gemeld word.

At the office of the Master, PRETORIA, and also of the magistrate of the district when stated in parentheses.

- 258/84—**Van Niekerk**, Johanna, 0205010005002, Luipaardsvlei Ouetehuis, Krugersdorp (Krugersdorp).—Truter Crous Wiggill & Vos, Westonaria.
- 8511/83—**Groenewald**, Johannes Rath, 2509035007002, Pretoriuslaan 195, Lyttelton, Verwoerdburg.—Boland Bank, Pretoria.
- 796/84—**Baker**, Dorothy Alvinia, 2003170051009, 88 Sir George Grey Street, Horison, District of Roodepoort; John Henry Baker, 1810085002005 (Roodepoort).—Abrahams, Israel, Doring & Kossuth, Roodepoort.
- 15084/82—**Rautenbach**, Matheus Gerhardus, 0604145001003, Katkoomkraal, distrik Standerton (Standerton).—Van Heerden Schoeman De Ville & Boer, Standerton.
- 9856/83/6C—**Denysschen**, Magdalena Gertruida, gebore Marais, 0311200005008, Anne Court 3, Potgietersrus (Potgietersrus).—Barnard & De Klerk, Pietersburg.
- 10503/82—**Wilson**, Constance Josephine, born Nesbitt, Plot 62, Ivydale, Pietersburg (Pietersburg).—Barnard & De Klerk, Pietersburg.
- 499/84—**Lubbe**, Barend Nicolaas, 4712055017004, Plot 60, Nanescol, Vanderbijlpark; Hester Johanna Maria Lubbe, 5103060063002 (Vanderbijlpark).—Volkskastrust, Klerksdorp.
- 8298/83—**Orr**, John Anthony, 2607125042002, Brightonhof 402, Ockersestraat 31, Hillbrow, Johannesburg, Supplémentêre; Alida Johanna Carolina Orr, 3211280021007 (Johannesburg).—Volkskastrust, Marshalltown.
- 14683/82—**Heinemann**, Chris Henry, 1508265043001, Connaughtlaan 26, Geduld-uitbreiding, Springs (Springs).—Volkskastrust, Marshalltown.
- 1470/84—**Hansen**, Andries Johannes, 4104125037008, Vuurpyllaan 23, Verwoerdpark, Alberton (Alberton).—Volkskastrust, Marshalltown.
- 2608/84—**Jansen**, Christoffel Johannes, 0703125009000, Koedoelaan 7, Leeuhof, Vereeniging; Margaretha Maria Jansen, gebore De Jager, 1411230016006 (Vereeniging).—Volkskastrust, Marshalltown.
- 4422/84—**Van der Merwe**, Helena Maria, 0001280007004, Huis Hermon, General de Wetstraat, Pretoria-Noord; Jacobus Daniël van der Merwe.—Volkskastrust, Pretoria.
- 1962/84—**Swart**, Adolf Johannes, 5103035068001, Huis 1, Mica Stasie, Mica; Eva Magdalena Catharina Swart, 5610270022006 (Phalaborwa).—Volkskastrust, Pretoria.
- 1775/84—**Van Aswegen**, Johannes David, 2601255012000, Agtsestraat 16, Waterval, Rustenburg; Petronella van Aswegen, gebore Esterhuizen, 2705270032008 (Rustenburg).—Volkskastrust, Pretoria.
- 13626/83—**Lowne-Hughes**, Oscar Binstead, Boekenhoutkloofstraat 1111, Booyens, Pretoria; Margaret Elizabeth Lowne-Hughes.—Volkskastrust, Pretoria.
- 2550/84—**Van Emmenis**, Frederik Adriaan, 1307275010005, Bulkop Tolwe; Aetha Elizabetha van Emmenis (Potgietersrus).—Volkskastrust, Pretoria.
- 3634/84—**Kruger**, Sarel Jacobus, 5706075015005, SAW Woonstelle 18, Combretumweg, Phalaborwa; Anna Susanna Kruger, gebore de Villiers, 5604110045006 (Phalaborwa).—Volkskastrust, Pretoria.
- 4008/84—**Pretorius**, Maria Elizabeth, 1509090015008, Perseel 84, Welgedacht, Springs; Jan Lodewyk Pretorius, 1112225010000 (Springs).—Volkskastrust, Marshalltown.
- 14525/83—**Rossouw**, Frederik Adriaan Jacobus, 3011255028007, Ficksburgweg 14, Suid-Heuwels, Johannesburg; Jacomina Hendrina Rossouw, 3309090109002 (Johannesburg).—Volkskastrust, Marshalltown.
- 77/84—**Olivier**, Christo, 5303165164008, Cumberlandweg 247, Kensington, Johannesburg; Hester Anna Carolina Olivier, 5505120163004 (Johannesburg).—Santamtrust, Johannesburg.

- 3500/83—Smith, Willem Stephanus, 305780456, Plot 30, Kameeldrif, Pretoria; Aletta Cornelia Smith, gebore Cloete, 356127552.—Boland Bank, Pretoria.
- 12768/83—Herbst, Naomi, 27/11/17, Plot 40, Heatherdale, Pretoria; Hendrik Jacobus Herbst, 1308035013008. Boland Bank, Pretoria.
- 14264/82—Van Niekerk, Adriaan Petrus, 354851704W, wewenaar, Maherrystraat 41, Potchefstroom (Potchefstroom).—Dyason, Odendaal & Van Eeden, Pretoria.
- 14274/82—Van Niekerk, Hester Anna Sophia, 354859195W, Maherrystraat 41, Potchefstroom; Adriaan Petrus van Niekerk, sedertdien oortede (Potchefstroom).—Dyason, Odendaal & Van Eeden, Pretoria.
- 6940/83—Barkhuizen, Percy Mayor, 3503115038002, 82 Eeufees Ave, Nigel (Nigel).—G. L. Jordaan & Co., Nigel.
- 6940/83—Barkhuizen, Percy Mayor, 3503115038002, 82 Eeufees Ave, Nigel (Nigel).—G. L. Jordaan & Co., Nigel.
- 7104/82—Scriven, Johanna Petronella, 2901160016009, Plot 112, Misgund, Eikenhof (Johannesburg).—Brink, Roos & Du Toit, Ceres.
- 1874/84—Rossouw, Johannes, 1801135002004, Homanstraat 85, Klerksdorp; Jacoba Elizabeth Glodina Rossouw, gebore Janse van Rensburg, 2204170010009 (Klerksdorp).—Erasmus Jooste, Klerksdorp.
- 2254/83—Coetzer, Hendrik Belzaser Louis, 4612205140005, Wendenlaan 87, Brakpan; Delores Johanna Coetzer, gebore Pretorius, 5208245140005 (Brakpan).—Van der Merwe, J. J., Brakpan.
- 8272/83—Hart, Richard Tamplin Reuben, 1909275015007, Plot 145, Theoville, Vanderbijlpark; Ella Magrietha Hart, born Cloete, Plot 145, Theoville, Vanderbijlpark, 250311003001 (Sasolburg).—Wade & Hills, Maclear.
- 3394/80—Venter, Pieter Willems Smuts, 473465127, Vaalfontein, distrik Groblersdal; Maria Georgina Cradocia Venter, gebore Helm, 0307070025001, Aanvullende Eerste en Finale (Groblersdal).
- 750/84—Deist, Johanna Maria Jacoba, 1007300033002, Geloftestraat 21, Warmbad; Karel Christiaan Frederik Deist, 0408295021005 (Warmbad).—Mathews, Lanser & Williams, Warmbad.
- 9541/83—Brits, Hendrik Arnoldus, 3412295069003, Baden Powellstraat 43, Vanderbijlpark; Hester Philippina Brits, gebore Brits, 3709150016007 (Vanderbijlpark).—Santamtrust, Potchefstroom.
- 1970/83—Meyer, Willem Petrus, 6206095165004, Flat 2, Vierfontein, Colliery; Ghislane Fay McCormack Meyer, born Stevenson, 6210270114108 (Viljoenskroon).—Santamtrust, Potchefstroom.
- 4456/83—Botha, Theodorus Hermanus, 3006145038000, 14 Pienaar Street, Brenthurst, Brakpan; Mervian Minie Botha, 4007030023007 (Brakpan).—Manfred Jacobs & Husted, Boksburg.
- 6661/83—Grimes, Frederick R6th, 0805165026008, Maroelalaan 12, Protea Park, Rustenburg (Rustenburg).—L. P. le Roux, Rustenburg.
- 2324/84—Gouws, Johannes Jacobus, 0710165035001, Anzoestraat 22, Primrose, Germiston (Vereeniging).—Santamtrust, Potchefstroom.
- 4770/83—Harvey, Olive Pearl, 309508605W, 49 Gerrit Maritz Avenue, Dalview, Brakpan (Brakpan).—Trollip, Joubert, Cowling & Janeke, Brakpan.
- 3365/83—Prinsloo, Hermanus, Jacobus Johannes, 370956734W, 857 Commercialstraat, Pretoria-Tuine; Gertruida Anna Elizabeth Prinsloo, 1712190026004.—Savage Jooste & Adams Ing., Pretoria.
- 9009/83—Venter, Alida, 364260600, Vlaktefontein, Broedersput, distrik Vryburg; Johannes Jacobus Venter, 1809075015001, Gewysigde (Vryburg).—Volkskastrust, Klerksdorp.
- 1739/84—Du Toit, Elizabeth Catharina, 0403080013002, Harrisaan 4, Flamwood, Klerksdorp (Klerksdorp).—Volkskastrust, Klerksdorp.
- 16182/83—De Koker, Johan Frederik, 4612235103007, Joubertstraat 32, Wolmaransstad, Eerste (Wolmaransstad).—Volkskastrust, Klerksdorp.
- 543/82—Blyth, Roderick 131155039001, Clifton, Lothair (Ermelo).—W. F. Landman, Ermelo.
- 484/84—Jansen van Rensburg, Hendrik Johannes Christofel, 2112195005005, Seyfertstraat 12, Stilfontein; Frederika Katharina Clementina Jansen van Rensburg (Klerksdorp).—Ben de Wet & Kie, Klerksdorp.
- 13545/83—Joubert, Willem Nicolaas, 2510015003003, Bovenstraat 31, Sannieshof, Gewysigde (Delareyville).—Volkskastrust, Klerksdorp.
- 844/84—Kruger, Christoffel Johannes Stephanus, 1806225021004, Kopstraat 10, Zeerust; Johanna Marthina Christina Susanna Kruger, 0707150023000 (Zeerust).—Volkskastrust, Klerksdorp.
- 960/84—Crafford, Hermanus Johannes, 6702115072006, Marijastraat 152, Wonderboom, Uitbreiding 2 (Pretoria-Noord).—Couzyn, Hertzog & Horak, Pretoria.
- 2108/80—Gromer, Jacob Joseph, 1310195045002, 41 Roxana Mansions, Brakpan (Brakpan).—Trollip, Joubert, Cowling & Janeke, Brakpan.
- 2441/83—Thornton, Laurence Bertram, 0905175035005, 6 Cymmar Flats, 3 Sabie Road, Selcourt, Springs (Springs).—Campbell, Bode Brown & Stewart, Springs.
- 16226/83—Pretorius, Magdalena Martha, 1412260017005, Whalleystraat 78, Makwassie; Johannes Marthinus Christian Daniel Pretorius, 1902145020000 (Wolmaransstad).—Volkskastrust, Klerksdorp.
- 13820/82—Kruger, Christoffel Petrus Philippus, 1308135042006.—Macintosh Cross & Farquharson, Pretoria.
- 16232/81—Meyer, Jacobus Johannes, 4907015105002, Verwoerdweg 159, Klipriviersdorp, Meyerton; Anna Martha Meyer, 5003300069001 (Vereeniging).—Mills & Ahlers Ing., Vereeniging.
- 8891/83—Du Toit, Lourens Mathys, 1103315014002, Boschpoort, Belfast; Anna Johanna du Toit, gebore Brits, 1601220005007 (Belfast).—Barclays Nasionale Bank, Nelspruit.
- 3701/83—De Carls, Arturo, 1908115035100, Beryl Farm 8, Nelspruit, Second and Final (Nelspruit).—Barclays National Bank, Nelspruit.
- 8915/83—Broodryk, Pieter Willem, 4810295015000, Malelane Ruskamp Malelane; Maria Izabella Broodryk, gebore Richter, 5102170048002 (Barberton).—Barclays Nasionale Bank, Nelspruit.
- 10873/83—Pretorius, Hendrik Petrus, 2204095044000, 19 Forrester Avenue, Selection Park, Springs; Lucy Magdalin Pretorius, born Van Rooyen, 3609300037004 (Springs).—Charles Sherman, Levin & Prosser Inc., Springs.
- 1330/83—McIntyre, Sarah Margaret, 9508070002004, 95 General Hertzog Road, Three Rivers, Vereeniging (Vereeniging).—Snijman, Smullen & Theo Rood, Vereeniging.
- 8691/80—Schormann, Rudolf Ernst, 020503500800, Cromdale, distrik Nelspruit; Martha Ellen Schormann, gebore Budewitz (Nelspruit).—Macrobert de Villiers & Hitge Ing., Pretoria.
- 7104/82—Scriven, Johanna Petronella, 2901160016009, Plot 112, Misgund, Eikenhof (Johannesburg).—Brink, Roos & Du Toit, Ceres.
- 2462/84—Kruger, Maria Petronella, 1709110007007, Bovenstraat 33, Sannieshof; Roelof Johannes Martinus Kruger, 1606235015008 (Delareyville).—Volkskastrust, Klerksdorp.
- 5959/83/9C—Knox, Maria Magdalena, 070104, Kleinbergstraat 109, Sterpark, Pietersburg (Pietersburg).—P. S. Buys, Pretoria.
- 2623/70—Chod, Leon, 356157680W, 120 Alice Street, Rietondale, Pretoria, Amended.—Goldberg, Kuhn & Lancesman, Pretoria.
- 5852/83—Van Bijlon, Susanna Francina, 3511220011004, Vuurpyllaan 27, Flimieda, Klerksdorp, Aanvullende; Eben Hercules van Bijlon, 3112305017006 (Klerksdorp).—Volkskastrust, Klerksdorp.
- 6633/83—Van den Bergh, 5504125019006, Blesbokstraat 13, Ventersdorp, Aanvullende; Esther van den Bergh, 5805300118004 (Ventersdorp).—Volkskastrust, Klerksdorp.
- 9110/77—Koekemoer, Hendrik Lammert, 9611185002008, Andries Spiesstraat 6, Roosheuvel, Klerksdorp (Klerksdorp).—Erasmus Jooste, Klerksdorp.
- 13138/83—Van Dyk, Joseph Daniël, 1811135028008, Southsideweg 12, Blyvooruitsig, 30 dae (Oberholzer).—Volkskastrust, Klerksdorp.
- 3956/83—Van Ryneveld, Gustav, 0303065004002, 15 Cuckoo Street, Klerksdorp, Second (Klerksdorp).—Hatting & Hart, Klerksdorp.
- 1594/83—Barnard, Maria Johanna, voorheen Reyneke, gebore Van der Schyff, 1304020020009, weduwee, dorp Eloff, tussen Delmas en Springs (Springs).—Fleischacks, Potchefstroom.
- 9214/81—Lewis, Noel, 2006155020006, 21 Gavin Glen, Johannesburg Road, Lyndhurst, Johannesburg (Johannesburg).—Charles Sherman Levin & Prosser Inc., Springs.

- 13334/81—**Wilken**, Pieter Hendrik, Plot 2, Akasia, Pretoria-Noord (Pretoria-Noord).—W. S. Coetzee & Fourie, Pretoria.
- 1988/84—**Ferreira**, Catherine Maria, 356114716W, Princess Christian Home, Middel Street, New Muckleneuk, Pretoria.—Savage Jooste & Adams Inc., Pretoria.
- 12248/82—**Goosen**, George Petrus Moreux, 6103215028008, Winkelhaakenkelkwartiere, Winkelhaakmyn, Evander (Evander).—Van der Walt & Hugo, Pretoria.
- 2354/83—**Karsten**, Jan Louis Roseau, 356310420, Wolmaranstraat 119, Jan Niemand Park; Hermina Christina Johanna Karsten, 4201100075001.—Teichert & Kruger, Pretoria.
- 4991/83—**Van Heerden**, Martha Aletha, 1405270012008, Harvest Crescent 105, Kings Highway, Pretoria.—Brink Pfaff & Vennote, Pretoria.
- 14264/82—**Van Niekerk**, Adriaan Petrus, 354851704W, wewenaar, Maherrystraat 41, Potchefstroom (Potchefstroom).—Dyason, Odendaal & Van Eeden, Pretoria.
- 14274/82—**Van Niekerk**, Hester Anna Sophia, 354859195W, Maherrystraat 41, Potchefstroom; sedertdien oorlede Adriaan Petrus van Niekerk, 354851704W (Potchefstroom).—Dyason, Odendaal & Van Eeden, Pretoria.
- 1870/84—**Roberts**, Maud Sophia, gebore Wernich, 022633832W, Queen Wilhelminalaan 268, Nuwe Muckleneuk, Pretoria.—Santamtrust, Bellville.
- 14346/82—**Du Plessis**, Hendrika Christina, 2309210014000, Hoewe 13, Maribank, Vanderbijlpark; Carel Jacobus du Plessis, 1212205026008 (Vanderbijlpark).—Anton M. Bouwer, Parys.
- 16198/83—**Greeff**, Gabriel Pieter, 1908255007000, Rietbokstraat 6, Potgietersrus; Anna Elizabeth Greeff, gebore Jordaan, 2306020005004 (Potgietersrus).—Syfrets Trust, Pretoria.
- 7991/83—**Hartzel**, Willem Jacobus, 1209255017002, Irelandweg 1, Eldoraig, Pretoria, Tweede en Finale.—Syfrets Trust, Pretoria.
- 195/84—**Van Deemter**, Magritha Johanna, 2903120032001, Enkeldoorn 52, Sprokkelaan, Faerie Glen, Eerste.—Syfrets Trust, Pretoria.
- 1635/82—**Erasmus**, Lourens Francois, 0601035004006, Harmonie, Virginia, Tweede en Finale (Virginia).—Syfrets Trust, Pretoria.
- 1254/82/4A—**Van Essen**, Albert, 3202275045002, Tom Jenkinsrylaan 168, Rietondale, Pretoria, Tweede en Finale; Jitske van Essen, gebore Damstra.—Syfrets Trust, Pretoria.
- 15080/83—**Engelbrecht**, Christiaan Lourens, 1008205009006, Paarlstraat 7, Ventersdorp; Louisa Petronella Engelbrecht, gebore Opperman, 1702123009006 (Ventersdorp).—Gillett Van Zyl & Nell, Ventersdorp.
- 2543/83—**De Beer**, Dirk Jacobus, 3503205043003, Hendrik Potgieterstraat 94, Lichtenburg; Susara Johanna Sophia de Beer, 3312300029002 (Lichtenburg).—Jan A. Lourens, Lichtenburg.
- 11199/80—**Van Oudtshoorn**, Elsie Margaret, 331133263W, widow, Queen Alexandra Home, 80 Eighth Avenue, Orange Grove, Johannesburg (Johannesburg).—Jack Cooper, Vereeniging.
- 8271/77—**Botha**, Frederik Jacobus, 2604105045006, Hoewe 400, Rietkol Landbouhoewes, Sundra, distrik Delmas, Derde en Finale; Thelma Botha, gebore Scheepers, 3708280023008 (Delmas).—P. A. Milstein & Seun, Delmas.
- 8271/77—**Botha**, Frederik Jacobus, 2604105045006, Hoewe 400, Rietkol Landbouhoewes, Sundra, distrik Delmas, Tweede; Thelma Botha, gebore Scheepers, 3708280023008 (Delmas).—P. A. Milstein & Seun, Delmas.
- 9821/83—**Robertson**, Mary Kennedy 9705050002000, Glengarry Estates, District of Letaba (Tzaneen).—Joubert & May, Tzaneen.
- 11813/83—**Werner**, John Peter, 1703135053005, 278 Luipaard Street, Krugersdorp, Bertha Margretta Werner.—Hack Stupel & Ross, Pretoria.
- 10968/82—**Baxter**, Richard Brian, 6008175041000, 228 Apple Orchids, Walkerville, Meyerton.—MacRobert De Villiers & Hitge Ing., Pretoria.
- 12855/81—**Ruysch**, Gordon William, 5410055105007, 8 Tangelo Street, Golden, Nelspruit (Nelspruit).—Swanepoel & Dreyer, Nelspruit.
- 11981/83—**Du Plessis**, Philippus Francois, 2812185007008, Leydsstraat 262, Rustenburg; Johanna Maria Elizabeth du Plessis, 2804300008003 (Rustenburg).—Dirk Grobler, Rustenburg.
- 884/83—**Bester**, Gert Frederick Heyns, 140529501455, Inkstraat 2, Carltonville (Carltonville).—Brand Wessels & Blignault, Bethlehem.
- 415/74—**Prinsloo**, Anna Maria Marthina, 9005270001001, die plaas Syferfontein, distrik Potchefstroom, Tweede Aanvullende (Potchefstroom).—Thiel Theron & Le Grange, Potchefstroom.
- 12181/83—**Roux**, Reginald Philip, 3209135064008, 6 Bulbul Street, Stuisbult, Springs; Ellen Susara Roux (Springs).—Ivan Davies Theunissen & Partners, Springs.
- 10228/83—**Janse van Rensburg**, Johannes Jacobus, 2302095025001, Launcestonweg 44, New Redruth, Alberton; Anna Elizabeth Susanna Janse van Rensburg, 2609230020006 (Alberton).—P. W. Janse van Rensburg, Alberton.
- 1204/81—**Chatterton**, Lynn May, 5505140032007, 12 Maddison Avenue, Risville, Vereeniging (Vereeniging).—Steyn, Lyell & Marais, Vereeniging.
- 12857/83—**Van Vuuren**, Hans Jacob Wessel, 1801265009001, Brakfontein 404, Swarttruggens; Cornelia Elizabeth van Vuuren, 2708010012009 (Swarttruggens).—Van der Merwe & Jooste, Koster.
- 15622/83—**Matejka**, Ludmila, 0403240037107, widow, 7 De Wet Street, Krugersdorp North (Krugersdorp).—J. B. Hugo & Cronje, Krugersdorp.
- 8491/83—**Van Staden**, Andries Gidion Gerhardus, 9410105008009, Tweefontein, distrik Bronkhorstspuit; Louisa Maria van Staden, gebore Ferreira, 0708300012008 (Bronkhorstspuit).—Pickard, Kirstein & Maree, Delmas.
- 10500/83—**Milne**, John Angus, 1908275030008, 9 Randleigh Avenue, Dawnview, Germiston (Germiston).—Wright, Rose-Innes, Louw & Wise, Germiston.
- 123/83—**Alexander**, Wilfred Joseph, 0108195015004, 172 Rebecca Street, Pretoria West, Second and Final.—L. A. Hové, Pretoria.
- 5648/83—**Moolman**, Johannes Zacharias, 0704115013002, Die Hoewe 87, Von Wiellighlaan, Verwoerdburg.—H. P. Krogh Viljoen & De Villiers, Pretoria.
- 819/83—**Basson**, Catharina Elizabeth, 366742104W, Drukfontein, distrik Greylingstad (Balfour).—Viljoen & Meek, Heidelberg.
- 7816/82/6B—**Pretorius**, Francois Johannes, 2307025035004, Middelwater, De Wildt, Posbus 16448, Pretoria-Noord, Derde en Finale (Pretoria-Noord).—Syfrets Trust, Pretoria.
- 4683/84—**Van Niekerk**, Gert Petrus, 0411215001008, Bothma-ouetehuis, Boksborg (Boksborg).—Santamtrust, Pretoria.
- 9364/83—**Van Rensburg**, Philippus Rudolph, 2801145038005, Clifflaan 482, Waterkloofrif, Aanvullende; Fransina Frederika J. van Rensburg, 4003020035002.—Santamtrust, Pretoria.
- 2962/84—**Nel**, Barend Johannes Daniel, 2803025040000, Millslaan 314, Danville, Pretoria; Jakomina Dorothea Nel, 3008120042007.—Santamtrust, Pretoria.
- 10045/83—**Schoeman**, Anna Sophia, 0407250027007, Kaberoelaan 409, Magalieskruin, Pretoria.—Santamtrust, Pretoria.
- 11377/83—**Small**, Johannes Lodewikus, 2902015065001, Wolmaransstraat 63, Jan Niemandpark; Ellen Georgina Small, gebore Merton, 356234887W.—Santamtrust, Pretoria.
- 13935/83—**Thomson**, Olive Ivy, 3707200051008, Constantiahof 22, Pleinstraat, Pretoria.—Santamtrust, Pretoria.
- 4597/84—**Van Niekerk**, Renchie Maria, 2002040001004, Cillierslaan 335, Lyttelton Manor, Verwoerdburg; Pieter Johannes van Niekerk, 2002235002007, 30 dae.—Santamtrust, Pretoria.
- Du Plooy**, Johanna Maria, 3906170076009, Ben Swartstraat 816, Rietfontein, Pretoria, Gewysigde Eerste en Finale.—Santamtrust, Pretoria.
- 4774/84—**Engelbrecht**, Hendrina Dorothea, 2006180028008, Schuurmanslaan 725, Pretoria-Tuine; Paul Jacobus Engelbrecht, 2111185022004.—Santamtrust, Pretoria.
- 3319/84—**Coetzee**, Joseph Adriaan, 4012105001003, Elisabethstraat 221, Doringkloof, Verwoerdburg.—Santamtrust, Pretoria.
- 4636/84—**Dendy**, George Thomas Frederick, 0610285022006, Charles Maberlystraat 27, Duitwelskloof; Ethel Dendy (Tzaneen).—Santamtrust, Pretoria.
- 2528/84—**De Klerk**, Gert Jacobus, 3907265079007, Henningsstraat 66, Randgate, Randfontein; Susanna Catharina Machdalena (Magdalena) de Klerk, gebore Holtzhausen, 3807190072004 (Randfontein).—Santamtrust, Johannesburg.
- 1071/84—**Smith**, Gert Jacobus, 2510095040008, Johannesburg; Maria Magdalena Smith, 3204030047000 (Johannesburg).—Santamtrust, Johannesburg.

- 9671/83—**Ley**, Peter Johannes, 3509215012003, Roodepoort; Magrita Magdalena van der Watt Ley, gebore Van Schoor, 4201250018009 (Roodepoort).—Santamtrust, Johannesburg.
- 11134/80—**Gerber**, Frans Antonie, 2109025065001, Clarence Court 24, Clarancestraat, Troyeville, Aanvullende; Jacomina Elizabeth Adriana Gerber, 3408080048004 (Johannesburg).—Santamtrust, Johannesburg.
- 16496/82—**Green**, Nicodemus Francois, 3008045061009, Sultanstraat 11, Unigray, Johannesburg; Dorothea Maria Sophia Green, 3110150042004 (Johannesburg).—Santamtrust, Johannesburg.
- 2091/84—**Potgieter**, Alexander Philip, 1410265039008, Windsorweg 89, Sunnyridge, Germiston; Catharina Elizabeth Gladys Potgieter, gebore Cornelius, 191127008003 (Germiston).—Santamtrust, Kempton Park.
- 9630/83—**Van Buren-Schele**, Petrus Jacobus, 1904255033005, Vierde Straat 5, Greymont; Elizabeth van Buren-Schele (Johannesburg).—Santamtrust, Johannesburg.
- 373/84—**Oelofse**, Marthinus Nicolaas, 3403225037004, Sesde Straat 24, Vrededorp, Johannesburg; Maria Cornelia Oelofse, 3603270036005 (Johannesburg).—Santamtrust, Johannesburg.
- 551/84—**Du Preez**, Andries Lourens, 2307215012003, Rifle Rangeweg 259, Haddon, Johannesburg; Jacoba Johanna du Preez, 2709290012008 (Johannesburg).—Santamtrust, Johannesburg.
- 4014/84—**Du Toit**, Hendrik Johannes, 1308105026005, Holzstraat 60, Krugersdorp-Wes (Krugersdorp).—Santamtrust, Johannesburg.
- 2366/84—**Casus**, Frans, 2604235051007, 10de Laan 33, Northmead, Benoni; Rosa Casus, 2902040040003 (Benoni).—Santamtrust, Kempton Park.
- 2742/84—**Obermeyer**, Martin Johannes, 3802045055007, Vierde Straat 41, Northmead, Benoni; Maria Jacoba Obermeyer, 4008180037003 (Benoni).—Santamtrust, Kempton Park.
- 11178/83—**De Jongh**, Martha Elizabeth Jacoba, 3308040033007, Nortonstraat 17, Elsburg, Supplementêre; Jacobus Adriaan de Jongh, 3001025044004 (Germiston).—Santamtrust, Kempton Park.
- Van Jaarsveldt**, Daniel Matthys, 3901145099004, Largoweg 9, Strubenvale, Springs, Verbeterde; Elma Myna van Jaarsveldt, 4109170084003 (Springs).—Santamtrust, Kempton Park.
- 2414/84—**Van der Walt**, Benjamin, 3307305046000, Sirkelstraat 21, Strubenvale, Springs; Lorette Sussana van der Walt, gebore Otto, 3909290013001 (Springs).—Santamtrust, Kempton Park.
- 6474/82—**Enslin**, Maria Susanna, 0902120014003, Boothahoes 89, Randfontein.
- 2300/84—**Swanepoel**, Pieter Gabriël, 1711155016000, Charl Cilliersstraat 20, Boksburg-Noord; Susanna Gesina Swanepoel, 2007300022004 (Boksburg).—Santamtrust, Kempton Park.
- 11389/83—**Albertyn**, Simon Frederik, 1309285043000, 18 De Bruin Street, Witfield, Boksburg; Ester Johanna Aletta Albertyn, 1206160043008 (Boksburg).—Barclays National Bank, Johannesburg.
- 12562/83—**Du Plooy**, Johannes Petrus, 2605305036000, Central Hotel, 10th Street, Maraisburg; Magrietha Johanna Sophia du Plooy, 30 September 1925, 2509300031000 (Roodepoort).—Barclays National Bank, Johannesburg.
- De Freitas**, Silvino Fidalgo, 1303235032003, 9 Toby Lane, Rosettenville, Johannesburg; Margaret Dorothy de Freitas, 2412160030008 (Johannesburg).—Santamtrust, Johannesburg.
- 9274/83—**Barrett**, Thomas, 0709295026005, 8 Andries Bruyns Street, Horison, Roodepoort; Martha Magdalena Barrett, born Powell, 1011230019008 (Roodepoort).—Blake & Scholtz, Roodepoort.
- 9397/83—**Charalambous**, Claudine Lucy Edith, 5506200021005, 81 Second Street, Orange Grove, Johannesburg (Johannesburg).—Syfrets Trust, Marshalltown.
- 11612/78ASR1B—**Roper**, John Michael, 4010075025014, 29 Maraisburg Road, Bosmont, Johannesburg; Dorothy Miriam Roper, born Bhana (Johannesburg).—Albert C. Fleischack, Johannesburg.
- 11466/83—**Rautenbach**, Lionel Godfrey, 18 Doorn Street, Observatory, Johannesburg (Johannesburg).—Albert C. Fleischack, Johannesburg.
- 15185/83—**Hirsch**, Walter, 0912125039004, 407 Burton Court, Pretorius Street, Hillbrow, Johannesburg (Johannesburg).—Syfrets Trust, Marshalltown.
- 3537/84—**Forder**, Marjorie, 2009210001003, 208 Frances Street East, Observatory (Johannesburg).—Syfrets Trust, Marshalltown.
- 12549/83—**Van der Meulen**, Anno Max, 3010045027006, Oorwinningstraat, Graskop, Eerste (Graskop).—Standardtrust, Pretoria.
- 96/84—**Wessman**, Annie Shindehutte, 2601060014001, 212 Leyds Street, Rustenburg (Rustenburg).—Standardtrust, Pretoria.
- 5606/82—**Van der Merwe**, Hester Sophia, 1405140027004, Werkendam, Ellisras, Tweede en Finale (Ellisras).—Standardtrust, Pretoria.
- 1013/84—**Appel**, Susanna Wilhelmina Johanna, 1309120007004, Emily Hobhouse Ouetehuis, Malherbestraat 55, Capital Park, Pretoria. —Standardtrust, Pretoria.
- 560/84—**Stanton**, Kenneth George, 4008175094001, Fonteinweg 81, Silverton; Madelaine Stanton, 5005260097005.—Volkskastrust, Pretoria.
- 619/84—**Stutterheim**, Paul, 1907225002000, Gremsboklaan 51, Monumentpark, Pretoria.—Volkskastrust, Pretoria.
- 1643/84—**Windell**, Johannes Hendrik Jacobus, 1111225024003, Greenstraat 196, Mayville, Pretoria; Lena Caroline Johanna Windell, gebore Francis, 0908020016006.—Volkskastrust, Pretoria.
- 3252/84—**Van Coller**, Erasmus Albertus, 1811115011008, Lensstraat 32, Clewer; Helena Johanna van Coller, gebore Viljoen, 1404020017003 (Witbank).—Volkskastrust, Pretoria.
- 939/84—**De Villiers**, Petrus Johannes Malherbe, 3201265041005, Kentweg 277, Meyerspark, Pretoria; Merlene Johanna de Villiers, 3502120034006.—Volkskastrust, Pretoria.
- 938/84—**Vermaak**, Salomon Cornelis Johannes, 1904135010009, Kareelaan 50, Middelburg; Anna Christina Vermaak, 2511070031004 (Middelburg).—Volkskastrust, Pretoria.
- 14740/83—**Reyneke**, Jacobus Arnoldus, 5310295058000, Maroelstraat 25, Middelburg; Salomina Maria Reneke, 5710161156007 (Middelburg).—Volkskastrust, Pretoria.
- 2085/84—**Van der Merwe**, Annemarie, 4905170061002, Broadbentstraat 22, Secunda; Marthinus Stephanus van der Merwe, 4712275067003 (Hoëveldrif).—Volkskastrust, Pretoria.
- 2972/84—**Stringer**, Thomas Fallon Francis, 1104165008003, President Krugerstraat 13, Middelburg (Middelburg).—Volkskastrust, Pretoria.
- 1723/84—**Nolte**, Matys Megiel, 2011265023007, Barnettstraat, Devon; Helena Susanna Du Plessis Nolte, 2309030043007 (Nigel).—Volkskastrust, Pretoria.
- 15928/80—**Opperman**, Patricia Violet, 1403170011006, Plot 155, Rhyndfieldlandbouhoewes, Benoni.—Hack Stupel & Ross, Pretoria.
- 2741/83—**Wessels**, Hans Jacob, 9311125001000, Robertsonweg 66, Warmbad (Warmbad).—Smit, Oelofse & Vennote, Pretoria.
- 8580/82—**De Klerk**, Christina Jacoba Adriana Louw, 2103115028003, Baldogstraat 5, Dinwiddie, Germiston (Germiston).—Die Sentrale Eksekuteurskamer, Pretoria.
- 15230/83—**Faul**, Gert Jacobus, 0011065008002, Ploverstraat 55, Oos-Driefontein (Carletonville).—Die Sentrale Eksekuteurskamer, Pretoria.
- 16118/83—**Louwies**, Jacobus Cornelius, 1512165025001, Plot 11, Marabeth, Pk. Tarlton; Elena Judith Louwies, gebore Schilz (Krugersdorp).—Haasbroek en Boezaart, Pretoria.
- 2908/84—**Lombard**, Catharina Christina Wilhelmina, 360926591, Sirkelweg 5, Tzaneen (Kaapstad, Tzaneen).—Volkskastrust, Pretoria.
- 12573/83—**Viljoen**, Jan Hendrik, 1902235016009, Rietgat, Munnik, Gewysigde; Margarietha Elizabeth Viljoen, 2112230023005 (Pietersburg).—Volkskastrust, Pretoria.
- 3338/84—**Hinsbeeck**, Johann Hendrik, 0906045003009, De Wildt, Brits, Gewysigde; Karoline Sophie Lucy Hinsbeeck, 1111150003006 (Brits).—Volkskastrust, Pretoria.
- 7197/83—**Joubert**, Andries Jacobus, 1409125006009, Knowlstraat 2, Barberton (Barberton).—Volkskastrust, Pretoria.

- 2337/84—**Pelser**, Pieter Willem Marx, 1710065041009, Lindehof 4, Lindestraat 590, Wingate Park; Alida Johanna Cornelia Felser, 1907300027005.—Volkskastrust, Pretoria.
- 3050/84—**Swart**, Hendrik Johannes, 1805305017007, 31ste Laan 575, Villieria, Pretoria; Louisa Johanna Swart, 1904120018009.—Volkskastrust, Pretoria.
- 11356/83—**Kühn**, Josephus Hendrik, 1003145017003, Emily Hobhouselaan 177, Potgietersrus (Potgietersrus).—Volkskastrust, Pretoria.
- 3961/84—**Nagel**, Jacobus Stephanus Johannes, 3601175034000, Lupinlaan 26, Primrose, Germiston; Elsie Petronella Nagel, 4411250030009 (Germiston).—Volkskastrust, Marshalltown.
- 1122/84—**Venter**, Suzanne Esperanse, 009140025005, Cointinlaan 10, Bonaero Park, Kempton Park; Jan Sarel Venter, 3912175005001 (Kempton Park).—Volkskastrust, Marshalltown.
- 12337/83—**Maritz**, Willem Johannes, 3303145019001, Kenyaweg 21, Florida Heuwels, Florida (Roodepoort).—Volkskastrust, Marshalltown.
- 13593/83—**Whelan**, Robert John, 2804015025003, Pretoriusstraat 112, Heidelberg; Ria Whelan, 3205300052000.—Volkskastrust, Marshalltown.
- 6668/83—**Hartman**, Josina Wilhelmina, 1805250011005, Bishopsgate 19, 13de Straat, Victory Park, Johannesburg (Johannesburg).—Santamtrust, Johannesburg.
- 16289/82—**Pruis**, Willem Michael, 370949238W, E. C. Pienaarstraat 3, Vanderbijlpark (Vanderbijlpark).—Santamtrust, Johannesburg.
- 12320/83—**Van Heerden**, Andries Hendrik, 2310155010003, Frankfortstraat 50, Suidheuwels, Johannesburg (Johannesburg).—Santamtrust, Johannesburg.
- 1958/84—**Pininski**, Johanna Catherina, 1208250663003, Plot 22, Bush Hill, Randburg; Eugene Pininski, 1404175016008 (Randburg).—Santamtrust, Johannesburg.
- 13585/83—**Taitz**, Pheenie, 0412165005007, 102 Elfreda Mansions, 34 Hopkins Street, Yeoville, Johannesburg (Johannesburg).—Van Jaarsveld, Vickers & Rootenberg, Roodepoort.
- 11613/81/OND/3B—**Tollman**, Wally Walter, 2208115025006, 19 Rollo Street, Cyriidene, Johannesburg (Johannesburg).—A. Saloner, Johannesburg.
- 11101/78—**Bloch**, Ian Ralph, 2401315051001, 30 Montagu Square, London W1, England (Johannesburg).—Raphaely-Weiner, Johannesburg.
- 4237/83—**Tinker**, Alfred John, 0712035011006, 10 Eastwold Way, Saxonwold, Johannesburg (Johannesburg).—Spencer Steward & Co., Johannesburg.
- 11091/83—**Roestorf**, Jan Jacob, 2110235010001, 30 Anson Street, Rhodesfield, Kempton Park; Maria Sussanna Roestorf, 2212020028006 (Kempton Park).—Barclays National Bank, Johannesburg.
- 7172/83—**Van der Walt**, Phillipus Christoffel, 1903265039002, 53 Eighth Avenue, Bezuidenhouts Valley (Randburg).—Barclays National Bank, Johannesburg.
- 15911/83—**Trieb**, Dorothea Johanna, 0506150014005, The Herald, 43 Soper Road, Berea, Johannesburg (Johannesburg).—Cliffe Dekker & Todd, Johannesburg.
- 7430/83—**Birch**, Arthur Hilson, 0108075017, 27 Castle Street, Fellside (Johannesburg).—Cliffe, Dekker & Todd, Johannesburg.
- 4753/81—**Queit**, Eva, 1211030011003, 718 Coronias Hotel, O'Reilly Road, Berea, Johannesburg, Amended (Johannesburg).—R. E. Chalom, Johannesburg.
- 1804/83—**Wolfaardt**, Jacobus Johannes, 3009015025008, Elandsfontein 334, Pk. Eikenhof (Johannesburg).—De Klerk & Le Roux, Johannesburg.
- 12397/83—**Blumenthal**, Bertha, 9804210006009, Our Parents Home, Spring Road, Gardens, Johannesburg (Johannesburg).—J. Segal, Highlands North.
- 7431/82—**Bosman**, George Charles Ross, 1202275004001, Farm Hartbeesfontein, Hekpoort (Krugersdorp).—R. G. Bosman, Johannesburg.
- 10721/83—**Stevenson**, Alfred Frank, 2706095035002, 27 Berg Street, Hamburg, Roodepoort; Jacomina Margrietha Stevenson (Roodepoort).—Standardtrust, Johannesburg.
- 14009/83—**Murphy**, Thomas, 214 Leonie Street, Doornkloof, Verwoerdburg.—Standardtrust, Marshalltown.
- 21/84—**Greef**, Maria Elizabeth Stuart, 9209070008006, Farm Lucky Acres, Eikenhof, Meyerton (Meyerton).—Standardtrust, Marshalltown.
- 13135/83—**Cary**, Walter Francis, 2212305009002, 25 Bella Street, Lakefield, Benoni (Benoni).—Standardtrust, Marshalltown.
- 13134/83—**Copeman**, Winston Frederick, 15 Elprado Flats, Jim Fouche Road, Randpark Ridge (Randburg and Boksburg).—Standardtrust, Marshalltown.
- 2188/84—**Du Toit**, Vera Patricia, 2209070016006, 1 Lomond Road, Blairstown, Johannesburg; James Dewar Greig du Toit (Johannesburg).—Standardtrust, Marshalltown.
- 14101/82—**Demetriades**, Elias, 876b Tsalitjibula Avenue, Kitwe, Zambia.—Standardtrust, Marshalltown.
- 2135/84—**Engelbrecht**, Jessie Niland, 331439070W, 89 13th Street, Parkhurst (Johannesburg).—Standardtrust, Marshalltown.
- 14787/83—**Graft**, Charles, 0307075014000, 17 Milton Rise, Sovereign Street, Bedford Gardens; Cornelia Maria Johanna Ludovica Graft, 0305110007005 (Germiston).—B. M. Berry, Randburg.
- 12550/83—**Maguire**, Brian, 2202025032004, 6 Woodlands, Stewart Drive, Bellevue Central, Johannesburg; Judy Megan Maguire, 4710280038001 (Johannesburg).—Barclays National Bank, Johannesburg.
- 5640/83—**Webb**, Myrtle May, 9304040003003, spinster, 45 Lascelles Road, Medowbrook, Germiston (Germiston).—Barclays National Bank, Johannesburg.
- 14475/83—**Benedek**, Yvonne Dorothea, 3609280063004, 56 Short Street, Rosettenville Extension, Johannesburg (Johannesburg).—Barclays National Bank, Johannesburg.
- 88/84—**Tupholme**, James Railton, 9203115007008, Moria Old Age Home, Krugersdorp (Krugersdorp).—Barclays National Bank, Johannesburg.
- 13706/83—**Van Rensburg**, Hermanus Pienaar, 2205085068008, Trevisa Flats 7, Hertz Boulevard, Vanderbijlpark (Vanderbijlpark).—Barclays National Bank, Johannesburg.
- 10879/83—**Richards**, Margaret Ethel Hepburn, 0805270013008, 9 Stanmore Road, Kensington (Johannesburg).—Barclays National Bank, Johannesburg.
- 8358/81—**Raymond**, David Pugh, 3911305036100, 4 Hugo Street, Beverley Gardens, Randburg.—Westtrust, Johannesburg.
- 7185/81/OND5C—**Phoshoko**, Eldrina Mmathau. Cassim Vilakazi Singh & Co., Belle Ombre.
- 8887/83—**Shakow**, George, 331421970, 1102 Bretton Manor, corner of Edith Cavell and Kaptein Streets, Hillbrow (Johannesburg).—Morgan, Meyer-son & Scalco, Braamfontein.
- 9760/83—**Dixon**, Betty, 1712060027009, 23 Merlene Mansions, corner of Abel and Tudhope Avenue, Berea, Johannesburg (Johannesburg).—Northern Trust Co., Marshalltown.
- 15650/82—**Belostoky**, Abe.—Levitt Kirson, Johannesburg.
- 16140/82—**Schweppe**, Lily (Leah), 101292388W, 206 Interlaken, Killarney, Johannesburg (Johannesburg).—M. J. Silver Rothbart & Company, Johannesburg.
- 16656/81—**Friedman**, Oscar, 9008235002007, 28 Southerklipriviersberg Road, Hill Extension, Johannesburg (Johannesburg).—Gordon Michalson Silver & Frack, Johannesburg.
- 15678/81—**Vincent**, Yvonne Wilhelmina, 5610080024004, 18 Peter Street, Meredale (Johannesburg).—Segal & Hoffmann, Johannesburg.
- 2679/82—**Hammond**, Frederick, 0612025031107, 42 Sandown Manor, Stella Street, Sandton (Johannesburg).—The Board of Executors, Johannesburg.
- 15424/83—**Theron**, Abraham van Wyk, 2305115020001, Sixth Floor, Cape House, corner of Fox and McLaren Streets, Johannesburg (Johannesburg).—The Board of Executors, Johannesburg.
- 13912/83—**Putman**, Terry Raymond, 25 Marula Street, Vandykpark, Boksburg; Vera Marianne Putman, formerly Flower, born Otto (Boksburg).—The Board of Executors, Johannesburg.
- 11226/83—**Himmelstern**, Ida Elsie Henriette, 0501210006108, 16 Kapteijn Street, Hillbrow, Johannesburg (Johannesburg).—Barclays National Bank, Johannesburg.

- 12387/83—**Viljoen**, Abraham Carel, 0611255017000, 33 Adonisweg, Edleen, Kempton Park; Maria Stefina Viljoen, gebore Grove, 0906150010005 (Benoni).—Barclays National Bank, Johannesburg.
- 5132/83—**Pryce-Rosser**, William, 0010055017007, 51 Tyrone Avenue, Parkview, Johannesburg (Johannesburg).—H. R. McLaren, Johannesburg.
- 13883/81—**Edelman**, Celia, 2109140018000, 26 Mount Ridge, 1 Minor Street, Yeoville (Johannesburg).—Damant Bostock & Co., Johannesburg.
- 12904/83—**Howard**, formerly Itzkin, Don, formerly Daniel Dennis, 653080337, 190 Seabourne Road, Southbourne, Bournemouth (Johannesburg).—Raphaely-Weiner, Johannesburg.
- 8507/80—**Frank**, Benno (Johannesburg).—John Briodo, Johannesburg.
- 2419/83—**Idzik**, Stanislaw Jakob, 1807215038107, 286 Pasteur Road, Rembrandt Park, Johannesburg (Johannesburg).—Barclays National Bank, Johannesburg.
- 2665/83—**Suliman**, Isa, 800329378A, 12 Honeysuckle Avenue, Lenasia (Johannesburg).—H. E. Sader, Marshalltown.
- 8226/83—**Strassburg**, Margaret.—Levitt Kirson, Johannesburg.
- 12753/83—**Shaplund**, Lily Cardew, 0006240019108, 97 17th Street, Parkhurst, Johannesburg (Johannesburg).—Standardtrust, Marshalltown.
- 6416/83—**Charik**, Frederick Emanuel, 0201045015009, 175 Cortayne Avenue, Mondeor, Johannesburg (Johannesburg).—Barclays National Bank, Johannesburg.
- 8523/80—**Mallalieu**, Johanna Engelbertha Penelope (Johannesburg).—K. E. Mallalieu, Johannesburg.
- 6480/80—**Guy**, Ernest Claridge, 4832 Zambia Close, Gaborone, Botswana, First (Johannesburg).—Godfrey Rabin & Partners, Johannesburg.
- 15936/83—**Farrell**, Fredrika Jacoba Stoffelina, 2211070014007, 1 Mackenzie Road, Simmerfield, Germiston; Edward George Willian Farrell, 1412095020000 (Germiston).—Barclays National Bank, Johannesburg.
- 14498/82—**Schwab**, Fanny (Fay), 20031400224003, 60 Mejon Road, Glenhazel (Johannesburg).—Jos Wilkov, Northlands.
- 10508/82—**Girnun**, Israel, 0508205013008, 9 Aylesbury, St John Road, St Andrews (Johannesburg).—McGum, St Andrews.
- 1311/83—**Jacobs**, Elizabeth Magdalea, 1807090002004, Morgenzon, Eerste (Bethal).—Barclays-Nasionale Bank, Pretoria.
- 244/84—**Jordaan**, Nicolaas Johannes, 2910015014002, Uniestraat 87, Rustenburg; Maria Wilhelmina Jordaan, gebore Fick, 2907190029003 (Rustenburg).—Barclays-Nasionale Bank, Pretoria.
- 11698/83—**Van den Bergh**, Frederick Jacobus, 2004135013001, Biccardstraat 96, Pietersburg; Jeanette Susara van den Bergh, gebore Pienaar (Pietersburg).—Barclays-Nasionale Bank, Pretoria.
- 9088/83—**Engelbrecht**, Frederick Johannes, 4410245011009, Leipoldstraat 35, Golsig, Middelburg (Middelburg).—Barclays-Nasionale Bank, Pretoria.
- 15475/83—**Prinsloo**, Jacobus Johannes Petrus Cornelius van Heerden, 2209285030008, Anglerlaan 5, Waterval-Boven; Maria Louisa Prinsloo, gebore De Lange (Waterval-Boven).—Barclays-Nasionale Bank, Pretoria.
- 6180/83—**De Klerk**, Helena Margaretha, 0411050016004, Kromdraai, Ermelo (Ermelo).—Barclays-Nasionale Bank, Pretoria.
- 11973/83—**Miller**, Elsie Johanna Catharina, gebore French, 1510240019007, Pricestraat 48, Breyten (Ermelo).—Barclays-Nasionale Bank, Pretoria.
- 13024/83—**Vermaak**, Matthys Jacobus Botha, 0502285002007, Rusoord-ouetehuis, Lydenburg; Martha Elizabeth Vermaak, voorheen Swart (Lydenburg).—Barclays-Nasionale Bank, Pretoria.
- 15403/83—**Maritz**, Susanna Margaretha, 1911110041008, Doraglen 301, Johnstraat 116, Pretoria.—Barclays-Nasionale Bank, Arcadia.
- 10847/83—**Hoy**, Donald Daniel, 3911035027007, 145 Banket Street, Waterkloof, Pretoria.—Barclays National Bank, Arcadia.
- 5291/83—**Kleynhans**, Evert Philippus, 4206245028005, Roojwal, Pk. Koelemansrus (Potgietersrus).—Pretoria Trustee, Arcadia.
- 14968/83—**Holloway**, John Charles, 1805055037006, 694 Swemmer Street, Rietfontein, Pretoria; Gertrude Cathline Holloway.—Barclays National Bank, Arcadia.
- 139/83—**Callitz**, Paulina Johanna, 0103080011002, Bedford (Bedford).—Barclays National Bank, Pretoria.
- 15872/83—**Suter**, Jessie Mabel Agatha, born Kelly, 2102050028002, Mothwa Haven Old Age Home, 353 Booysen Street, Eloffsdal, Pretoria; Sydney Clarence Suter.—Barclays National Bank, Pretoria.
- 12989/83—**Oberholzer**, Christoffel Johannes, 0010115002007, Moerbeilaan 111, Wonderboom, Pretoria, Verbeterde Eerste.—Barclays-Nasionale Bank, Pretoria.
- 8306/83—**Rabie**, Barend Jacobus, 2410255034000, Sesde Laan 20, Thabazimbi; Hendrina Cecilia Rabie, gebore Smit (Thabazimbi).—Barclays-Nasionale Bank, Pretoria.
- 16100/83—**Bezuidenhout**, Roelof Cornelius, 0604045003000, Munnikstraat 56, Louis Trichardt (Louis Trichardt).—Barclays-Nasionale Bank, Pretoria.
- 13855/83—**Diedericks**, Gert Nicolaas, 1607165011009, Koster; Johanna Catharina Wilhelmina Diedericks, gebore Theron (Koster).—Barclays-Nasionale Bank, Pretoria.
- 6373/83—**Naude**, Jeremia Daniel, 0802255013004, Steynstraat 9, Carolina; Petronella Johanna Fredrika Naude, 0903300012007 (Carolina).—Barclays-Nasionale Bank, Pretoria.
- 8305/83—**Janse van Rensburg**, Gertruida Johanna Helena, gebore Engelbrecht, 3012100028002, Jakkalsfontein, Bronkhorstspuit; Hermanus Petrus Janse van Rensburg, 1710285002003 (Bronkhorstspuit).—Barclays-Nasionale Bank, Pretoria.
- 11705/82—**Herbst**, Willem Jacobus, 3204205015006, Munnikstraat 48, Louis Trichardt, Tweede en Finale; Hermina (Hermine) Maria Herbst, gebore Prins (Louis Trichardt).—Barclays-Nasionale Bank, Pretoria.
- 12937/83—**Erasmus**, Andries Jacobus, 2102055003002, Pleinstraat, Machadodorp (Belfast).—Barclays-Nasionale Bank, Pretoria.
- 5181/83—**Coetzee**, Ruth Eileen, 0208290013001, Ouetehuis, Zeerust (Zeerust).—Barclays-Nasionale Bank, Pretoria.
- 10895/83—**Du Toit**, Patrick Willem Johannes, 1807045032007, Plot 100, Bultfontein, Pretoria-Noord; Wilhelmina Elizabeth Johanna du Toit.—Barclays-Nasionale Bank, Arcadia.
- 14812/82—**Jurrius**, Rachele Cornelis, 2112160027000, p/a Ekonomiese Ontwikkelingskorporasie Bpk., Karel Schoemangebou, Skinnerstraat, Pretoria; Dirk Elibert Jurrius, 2410305039009.—Schumann Van den Heever & Slabbert, Kempton Park.
- 16101/83—**Coetzee**, Willem Francois, 3206165017005, Nirvanastraat 16, Witfield, Boksburg; Lea Jacoba Adriana Coetzee (Boksburg).—Standardtrust, Marshalltown.
- 2092/84—**Prinsloo**, Nicolaas Dirk, 4304125094005, Sarellaan 243, Mountain View, Pretoria; Theresa Prinsloo, 5508260100000.—Santamtrust, Pretoria.
- 537/84—**Van Blerk**, Bernardus, 5702155051002, Lievaartstraat, Proklamasie Heuwel; Hendrina Johanna van Blerk, 4802010022007.—Santamtrust, Pretoria.
- 2499/83—**Venter**, Andries Jacobus, 2103245004007, Plot 47, Jakkalsdans, Moloto, Tweede en Finale.—Standardtrust, Marshalltown.
- 11945/83—**Goosen**, Pieter Willem, 1012205029006, Sewende Laan 10, Melville, Johannesburg; Martha Aletta Goosen, 1311300048006 (Johannesburg).—Standardtrust, Marshalltown.
- 1618—**Dunn**, Martinus Gerhardus, 5510205046009, Victoria Towers 11, Sarel Celliersstraat, Alberton, Suplementêre Eerste en Finale (Alberton).—Santamtrust, Pretoria.
- 5986/83—**Harrington**, Hester Jacomina, 1303090028009, Majettegebou 7, Burnettestraat 1066, Hatfield.—Santamtrust, Pretoria.
- 975/84—**Burger**, Willem Abraham, 5602135079000, Perelstraat 70, Rayton; Christina Louisa Burger, 5912280084006 (Rayton).—Santamtrust, Pretoria.
- 3683/83—**Hattingh**, Eugene Darius, 6201255077008, Edelstaal, Kwaggaweg, Pretoria-Wes, Tweede Aanvullende Eerste en Finale.—Santamtrust, Pretoria.
- 562/84—**Otto**, Petrus Jacobus Laurens, 1101305038007, Montanawoonstelle 309, hoek van 24ste Laan en Michael Brinkstraat, Villieria; Susanna Wilhelmina Martina Otto, gebore Pieterse, 2609120063009.—Santamtrust, Pretoria.

- 358/84—**Jansen van Vuuren**, Stephanus Petrus, 2110245017004, Corellilaan 680, Les Marais, Pretoria; Elizabeth Jansen van Vuuren, gebore Schöltz, 2406090042000.—Santamtrust, Pretoria.
- 3400/84—**Van der Walt**, Nicolaas, 5204155095000, Rawsonlaan 1446, Waverley, Pretoria; Martina Cornelia van der Walt, 5809040102005.—Santamtrust, Pretoria.
- 1420/84—**Le Roux**, Charles Murray, 1404215038004, Monumentlaan 324, Verwoerdbrug; Elsie Maria le Roux, gebore Van Wyk, 1911050042008.—Santamtrust, Pretoria.
- 8718/83—**Kromberg**, Gustav Adolf, 3407025031000, Belgravestraat 33, Bryanston, Sandton, Eerste Likwidasië en Distribusie (Randburg).—Syfrets Trust, Marshalltown.
- 13337/83—**Raubenheimer**, Gertruida Isabella, 1305310004009, 27 Faunce Road, Robertsham, Johannesburg; Hilgard Petrus Raubenheimer, 1010085005005 (Johannesburg).—Barclays National Bank, Johannesburg.
- 15652/83—**Potgieter**, Willem Jacobus, 4412095024009, Derde Laan 115, Geduld, Springs; Maria Susanna Potgieter, 4208260020008 (Springs).—Santamtrust, Kempton Park.
- 13978/83—**Malan**, Johanna Maria Aletta, 2109160041007, 15de Laan 6, Newlands, Johannesburg (Johannesburg).—Syfrets Trust, Marshalltown.
- 13542/83—**Hughes**, Godfrey, 1205145030007, Kokstraat 142, Potchefstroom (Potchefstroom).—Standardtrust, Marshalltown.
- 14506/83—**Kruger**, Carel Benjamin, 5603105074005, Van der Stelstraat 45, Westonaria; Marianne Johanna Elisabet Kruger, 6110040027006 (Westonaria).—Santamtrust, Johannesburg.
- 15276/82—**Van Zyl**, Jan Johannes Jacobus Petrus, 4409095002001, Stumkestraat 9, Mindaloro, Krugersdorp (Krugersdorp).—Santamtrust, Johannesburg.
- 2494/84—**Upton**, Elsie Maria, 0810210021004, Doverstraat 7, Westdene, Johannesburg (Johannesburg).—Santamtrust, Johannesburg.
- 15286/82—**Van Zyl**, Maria Cornelia, 4610110004001, Stumkestraat 9, Mindaloro, Krugersdorp (Krugersdorp).—Santamtrust, Johannesburg.
- 9369/83—**Stopforth**, Jan Johannes Jurgens, 2903015041000, Rosamondstraat 8, Florida-uitbreiding 2; Johanna Susanna Stopforth, 4909300011002 (Roodepoort).—Santamtrust, Johannesburg.
- 5750/83—**Triegaardt**, Christina Gertruida Wilhelmina, 1203300002000, Vierde Laan 36a, Parktown-Noord, Gewysigde (Johannesburg).—Santamtrust, Johannesburg.
- 14937/83—**Van der Merwe**, Johanna Maria Jacoba, 1611200029000, Pietersburgstraat 86a, Pietersburg; Diederik Petrus Rudolph van der Merwe, 0711075029001, 30 dae (Pietersburg).—Santamtrust, Middelburg.
- 3284/84—**Oosthuizen**, Johannes Hendrikus, 5301245003006, Foskorwoonstel, Phalaborwa, 30 dae (Phalaborwa).—Santamtrust, Middelburg.
- 478/84—**Pienaar**, Nicolaas Johannes, 6212055055003, Sanlamhof 103, Witbank (Witbank).—Santamtrust, Middelburg.
- 548/84—**Du Preez**, Pieter Johann, 3509155014004, Eufeesstraat 30, Middelburg (Middelburg).—Santamtrust, Middelburg.
- 505/81—**Martin**, Ernest, 4807015016003, geskei, Plot 89, Magalies Moot, Pretoria.—De Klerk Myburgh & Van Wyk, Pretoria.
- 8678/81—**Smith**, Thomas James, 1504045011004, St Liversstraat 36, Stilfontein, Klerksdorp; Anna Sophia Smith, gebore Coetzee, 1902240035002 (Klerksdorp).—Hofmeyr Van der Merwe, Pretoria.
- 7790/82—**Kruger**, Jan Hendrik, 3009055007007, Wesstraat 460, Pretoria-Noord; Sophia Magrietha Kruger, gebore Cronje, 3009210070007 (Wonderboom).—P. A. J. Heiberg, Pretoria-Noord.
- 2971/83—**Avery**, Kenneth James, 2107055041009, Spiesstraat 13, Annlin (Wonderboom).—P. A. J. Heiberg, Pretoria-Noord.
- 8762/83—**Rossouw**, Sophia Eileen, 3104010010004, plaas Grootkop, distrik Badplaas (Carolina).—D. P. S. Badenhorst, Pretoria.
- 2118/82—**Van Heerden**, Carel Nicolaas, 0502175007009, Van Combrinkstraat 36, Carolina, Aanvullende (Bethal).—Ehlers & Vennote Ingelyf, Pretoria.
- 5040/82—**Prinsloo**, Cornelia Petronella, 403273964W, Clarkstraat 199, Brooklyn, Pretoria, Gewysigde Eerste en Finale.—Couzyn, Hertzog & Horak Ing., Pretoria.

KAAP • CAPE

By die kantoor van die Meester, KAAPSTAD, en ook van die landdros van die distrik wanneer dit tussen hakies gemeld word.

At the office of the Master, CAPE TOWN, and also of the magistrate of the district when stated in parentheses.

- 7777/83—**Coaton**, Susanna Johanna, Hooggelegenweg, Durbanville (Bellville).—Volkskastrust, Kaapstad.
- 4834/82—**Hart**, Errol Westley, 3712185018006, Marsstraat 28, Vredenburg (Vredenburg).
- 1320/84—**Vivier**, Franciscus Fredricus, 0612015015003, Danie Theronstraat 22, Beaufort-Wes; Johanna Berlina Vivier, gebore Delport, 0903010017007 (Beaufort-Wes).—John D. Crawford & Seun, Beaufort-Wes.
- 2655/84—**Ackerman**, Cornelius Petrus, 1809195001006, De Hoek, Touwsrivier; Helena Barendina Ackerman, 2609200021000, 30 dae (Worcester).—Volkskastrust, Kaapstad.
- 1355/84—**Blumer**, Wilhelm Johann Leonhard, 1210225037104, Rieslingstraat 19, Steynsrus, Somerset-Wes (Somerset-Wes).—Volkskastrust, Kaapstad.
- 7358/83—**Davidson**, James, 25 Cardiff Avenue, Belvedere, Harare, Zimbabwe.—Findlay & Tait Incorporated, Cape Town.
- 265/84—**Botha**, Judith Sarah, gebore Du Plessis, 3402230009008, Uniestraat 5b, Somerset-Oos.—M. A. Botha, Somerset-Oos.
- 8048/83—**Serfontein**, Petrus Ebenhaezer, 1802205022005, Moerasrivier, distrik Oudtshoorn (Oudtshoorn).—Volkskastrust, Kaapstad.
- 1636/84—**De Villiers**, Dirk Johannes de Jong, 2312075018009, Lyonstraat 4, Worcester; Cornelia Jacoba de Villiers, gebore Reynecke, 2510030030007 (Worcester).—Volkskastrust, Kaapstad.
- 7432/83—**Noor**, Sayed Mohamed, 3802185043029, Oosterligstraat 17, Strand; Fareda Noor, gebore Mohamed, 3608060032023 (Strand).—Murray Smith & Swanepoel, Strand.
- 6426/83—**Muller**, Helgard Petrus, 3110115004008, Dagbreek, Mosselbaai; Loma Muller, gebore Smalberger, 3807050047005 (Mosselbaai).—Volkskastrust, Kaapstad.
- 1319/84—**Swiegelaar**, Helena Johanna, gebore Van Eck, 3409200014009, Oostelikeweg 54, Oudtshoorn; Hendrik Swiegelaar, 5006025072002 (Oudtshoorn).—Volkskastrust, Kaapstad.
- 6524/83—**Christians**, Peter John, 3202185049101, Fouriestraat 12, Bellville-Suid; Yvonne Elsie Petersen, 014771535K (Bellville).—Marais Müller, Kuilsrivier.
- 1592/84—**Lourens**, Matthys Johannes, 9104175001008, Dennelaan 9, Robertson (Robertson).—Boland Bank, Montagu.
- 1048/67—**Berry**, Adolph Frederick, Grassy Park, Amended First and Final; Ethel Lilian Berry, born Ford (Wynberg).—Guthrie & Rushton, Fish Hoek.
- 5191/83—**Liebenberg**, Abraham Johannes, 9907235008007, Hoogstraat 4, Piketberg (Piketberg).—Boland Bank, Moorreesburg.
- 3507/65—**Smit**, Johannes Nicolaas, 100780742, Hoofweg, Velddrif, Gewysigde en Finale (Laaiplek).—Swemmer & Levin, Vredenburg.
- 6455/83—**Siebritz**, Daniel Nicolaas, 4710315024018, Februariestraat 50, Cloeteville, Stellenbosch; Pamela Magdalena Siebritz, gebore Rhode, 4908070094016 (Stellenbosch).—Boland Bank, Stellenbosch.
- 7469/82/6A—**Nash**, Doreen Elizabeth Margaret, gebore Wells, 1302030029002, Oxfordstraat 15, Goodwood (Bellville).—Du Plessis Fourie Basson & Veldtman.
- 4667/83—**Hannie**, Norman Stanley, 5912065047012, 7 Fountain Road, Hornlee, Knysna (Knysna).—Strydoms, Knysna.
- 3799/83—**Watson**, Patrick Campbell MacDougall, 8502035001004, Heriot, Stander Street, George (George).—Walker Malherbe Godley & Field, Cape Town.
- 4349/80/5C—**Snyman**, Martha Elizabeth, 0702130016000, Trichardstraat 25, Ceres (Ceres).—Paul H. S. van Zijl, Ceres.

- 7578/83—**Van Rensburg**, Jan Hendrik, 0709225030002, Williamstraat 56, Parow, Jacoba Lawrence van Rensburg (Bellville).—André La Cock & Kie., Kaapstad.
- 620/83—**Martin**, Frank James, 4107255063017, 93 Goodhope Street, Bellville South; Regina Magdalene Martin, born Rose, 4610020072015 (Bellville).—R. H. Stuurman & Co., Bellville South.
- 7292/83—**Lourens**, Jacoba Margaretha Petronella, gebore Hübinger, 0807310001001, Huis Esperanza, Strand (Strand).—Boland Bank, Bredasdorp.
- 1235/83—**Kirkman**, Irene Purdon, born Shone, 9 Moffat Street, Hermanus (Hermanus).—Guthrie & Theron, Hermanus.
- 8156/83—**Ollewagen**, Johannes Petrus, 1312205037003, Sunny Side-ouetehuis, Plumstead; Gertruida Elizabeth Johanna Ollewagen (Plumstead).—Boland Bank, Caledon.
- 8227/83—**Streicher**, Grace, gebore Smith, 1107260036001, Merrimanstraat 90, George; Johannes Gerhardus Streicher, 1204245049009 (George).—Boland Bank, Caledon.
- 4361/82—**Hendrikse**, Annie, born Ross, 21 Voorspoed Road, Greenhaven, Athlone, Amended First and Final (Wynberg).—Frank Bernadt & Joffe, Cape Town.
- 1216/84—**Rossouw**, David Hendrik Jeremias, 1705015004008, Louis Bothastraat 3, Huguenot (Paarl).—Boland Bank, Paarl.
- 6991/83—**Nel**, Jacobus Adriaan, 2510315032009, Cloudskraal, Nieuwoudtville; Johanna Nel, gebore Mostert, 3009080052002 (Calvinia).—Volkstrust, Kaapstad.
- 6659/83—**Paterston**, Helena Catharina, gebore Geldenhuys, 0810220023008, weduwee, Silver Oakswoonstelle D11, Hoofweg, Hermanus (Hermanus).—Boland Bank, Caledon.
- 8059/83—**Meyers**, Ellen Stuart, gebore McLeod, 1012030029007, weduwee, Kimberleystraat 143, Goodwood (Goodwood).—D. P. de Klerk & Van Gend, Kaapstad.
- 7360/83—**Gouws**, Cornelis Johannes, 9908155003002, Vrisgewaagd, Prins Albert; Mieta Gouws, gebore Alberts, 1708220020009 (Prins Albert).—Markotter & Van der Walt, Prins Albert.
- 2217/84—**Naudé**, Anna Hendrica Christina, gebore Theart, 2212040037003, Elmwoodstraat 9, Parowvallei; Andries Louis Naudé, 2401015018003 (Parow).—Santamtrust, Bellville.
- 6495/83—**Blockley**, Zilla Marion, formerly Whitfield, born Barnes, 9810200004003, 86 Pluto Road, Plumstead (Wynberg).—Barclays National Bank, Cape Town.
- 7856/83—**White**, Robert, 0409255003009, 2 Protea, Lourens Street, Somerset West (Somerset West).—Barclays National Bank, Cape Town.
- 574/83—**Maguire**, James Francis, Harare.—Barclays National Bank, Cape Town.
- 7435/83—**Ashforth**, Phyllis, 0011050011102, 61 Rotherfield Road, Plumstead (Wynberg).—Barclays National Bank, Cape Town.
- 5146/83—**Hugo**, Francois Daniel, 4803095088004, Van Zylstraat 13, Bonnievale (Swellendam).—Barclays-Nasionale Bank, Kaapstad.
- 6611/83—**Uys**, Andries Petrus, 0005235004008, Huis Zenobia du Toit, Heidelberg (Heidelberg).—Barclays-Nasionale Bank, Kaapstad.
- 6919/83—**Engelbrecht**, Renier Andries Jakobus, 1104175040004, Van Rooyenhospitaal, Garies (Garies).—Barclays-Nasionale Bank, Kaapstad.
- 6954/83—**Engelbrecht**, Johannes Petrus Smit, 3011295011005, Hoofweg 542, Nababeep; Maria Magdalena Sophia Engelbrecht, gebore Van der Westhuizen, 3003290023002 (Springbok).—Barclays-Nasionale Bank, Kaapstad.
- 5338/83—**Johnson**, Michael Charles, 3203115042001, 37 Killarney Road, Bellville (Bellville).—Barclays National Bank, Cape Town.
- 7801/83—**Bulmer**, Ella Doreen, 0309060025009, Kendrick House, Thornton (Wynberg).—Barclays National Bank, Cape Town.
- 1286/84—**Mellish**, Maria (Marie) Elizabeth, 9107270006004, Booth Memorial Hospital, Upper Orange Street, Oranjezicht.—Barclays National Bank, Cape Town.
- 1512/84—**Koen**, Petrus Johannes, 2205255015003, Wrenchweg 73, Parow; Petronella Johanna Koen, gebore Jordaan, 2210090043004 (Bellville).—Santamtrust, Bellville.
- 2692/84—**Watson**, Richard Charles, 0209235009005, 9 Komassie Road, Old Place, Knysna (Knysna).—Barclays National Bank, Port Elizabeth.
- 9119/83—**Reynolds**, Louis George von Bratt, 1205035014004, Longships Drive, Plettenberg Bay, First; Elizabeth Margaretha de Waal Reynolds, born Boonzaaier, 160310005008 (Knysna).—Barclays National Bank, Port Elizabeth.
- 6845/83—**Fourie**, Jasper Johannes, 2701055002001, Mauritiussingel 86, Glenivle, Bellville; Christina Johanna Sophia Fourie, gebore Smit, 2809040001002 (Bellville).—Santamtrust, Bellville.
- 2226/84—**Badenhorst**, Frans Hendrik Lourens Gerhardus, 1412125016002, Olmlaan 5, Worcester; Anna Gertruida Badenhorst, gebore Greeve, 0606070018001 (Worcester).—Santamtrust, Bellville.
- 2171/84—**Fick**, Jacobus Christoffel, 1109215039007, Hopkinsstraat 41, Parow; Isabella Maria Magdalena Fick, gebore Van Schalkwyk, 1608310027007 (Bellville).—Santamtrust, Bellville.
- 7680/83—**Pelston**, Edward Andrew, 4712235026016, Durrellstraat 30, Mandalay, Michels Plein; Philipina Pelston, gebore Stuart, 5112130124017 (Wynberg).—Santamtrust, Bellville.
- 7982/83—**Dreyer**, Hendrik Johannes, 4201195084009, Turnerstraat 16, Windsopark, Kraaifontein; Sofia Aletta Dreyer, gebore Kotze, 450718048009 (Bellville).—Santamtrust, Bellville.
- 7249/83—**Stofberg**, Margaretha Johanna Malan, gebore Le Roux, 0404010025009, Huis Lafras Moolman, Rawsonville (Worcester).—Boland Bank, Worcester.
- 311/84—**Vivier**, Johannes Samuel, 1508175004002, Rooiheuvel, Beaufort-Wes, Eerste; Catharina Petronella Francina Vivier, gebore Esterhuizen, 2507090019003 (Beaufort-Wes).—John D. Crawford & Seun, Beaufort-Wes.
- 4547/83/1D—**Böhmke**, Edith Margaret, 1002270015006, 1 Alvin Crescent, Somerset West; Matthias Enckhausen Böhmke, 1203065002007 (Somerset West).—Louw & Key, Somerset West.
- 7942/83—**Ochse**, Karel Hendrik, 2010255003003, Hoofweg 350, Hermanus (Hermanus).—Volkstrust, Kaapstad.
- 766/82—**Cupido**, Jacob Isaac, 096236890K, 6a Rosary Street, Paarl; Sophia Julia Cupido, born Ontong, 096738301K (Paarl).—S. G. Hoffman & Van Tonder, Paarl.
- 9040/83—**Veenstra**, Ruth Luise, 2302110056007, 7 Cross Street, Hermanus (Hermanus).—Guthrie & Theron, Hermanus.
- 6224/77—**Brauer**, Albert Carl Christiaan, 02165812W, Meulsteensvlei, Nieuwoudtville, Gewysigde Eerste en Finale Likwidasië en Distribusie (Bellville).—Kruger & Van Copenhagen, Vredendal.
- 5518/77—**Munz**, Edward George, 022304698W, 11 Bellevliet Road, Observatory; Shirley June MacDonald, formerly Munz, born Addinall.—L. Kadish & Company, Woodstock.
- 7124/83—**Simson**, Betty, 0608150024008, 302 Edin Roc, Oliver Road, Sea Point.—Prisman & Wilson, Cape Town.
- 2781/82—**Velk**, Simon Louis, 9601155010008, 401 Knightsbridge, Beach Road, Sea Point, Supplementary Second and Final.—Arthur E. Abrahma & Gross, Cape Town.
- 6875/83—**Thomson**, Cyril Ronald Johnstone, 1312215026007, 53 Dale Street, Rondebosch East, Cape Town (Wynberg).—Klossers, Cape Town.
- 8373/82—**Dawson**, William Fairbairn Roger, 53 Dyke Road, Penhill, Eerste Rivier, Amended First and Final Liquidation and Distribution (Kuils River).—Van Reenen & Partners, Bellville.
- 3497/83—**Karpakis**, Barbara Elizabeth, 2711040048001, 4 Kinbrae Court, Gilmourhill Road, Tamboerskloof.—Swanepoel, Uys & Rushton, Cape Town.
- 4004/83—**Efrolken**, Leah, Highlands House, 234 Upper Buitenkant Street, Cape Town.—Arthur E. Abrahams & Gross, Cape Town.
- 2291/84—**Pankhurst**, Sheridan Frederick, 3805265037001, Wimbledonweg 43, Edgemeed; Annette Elsabe Pankhurst, voorheen Jones, gebore Knoetze, 4908180088007 (Goodwood).—Santamtrust, Kaapstad.
- 5657/83—**Button**, David George, 4609155005006, Constantia Dale 602, Plumstead (Wynberg).—Santamtrust, Kaapstad.
- 997/84—**Theunissen**, Marthinus Wilhelmus, 1303215024008, Belladonnaaan 20, Kaapstad; Anna Magaritha Theunissen, gebore De Villiers, 1703130051004.—Santamtrust, Kaapstad.

- 1833/84—**Powell**, David Meredith Willsdon, 3109065024008, 4 Hadfield Road, Meadowridge, Bergvliet (Wynberg).—Santamtrust, Cape Town.
- 1026/84—**Tommy**, Melvyn, 4307125068010, 29 Michigan Way, Portlands, Mitchells Plain; Jaya Letchmie Tommy, born Naidoo, 4607310042054 (Wynberg).—Santamtrust, Cape Town.
- 671/84—**McOwen**, Albert Horace, 1309115002002, P.O. Box 224, Hermanus (Hermanus).—Fairbridge Arderne & Lawton, Cape Town.
- 8176/83—**Joseph**, George, 22404189, Little Key, Third Avenue, Grassy Park; Elizabeth Joseph, born January (Wynberg).—C. & A. Friedlander, Claremont.
- 2877/83—**Mervis**, Sterne, 427343769, 101 Bellevue House, Bellevue Road, Sea Point, First.—Hurwitz Lewak, Cape Town.
- 2998/83—**Visser**, Victor James, 117930886, 7 Maureen Avenue, Bellville South (Bellville).—D. J. Smit & Siebrits, Bellville.
- 8261/81—**Zbenovich**, Sholem, 15 Garfield Road, Oranjezicht, Supplementary Liquidation.—H. Tarley & Company, Cape Town.
- 7496/83—**Slabbert**, Jan Johannes de Jongh, 9809055008002, Di Santa Barbara, St John's Road, Sea Point.—Syfrets Trust, Cape Town.
- 9112/83—**McIntyre**, Charles Walter Grant, 9810215009005, 40 Garfield Road, Claremont (Wynberg).—Syfrets Trust, Cape Town.
- 7464/83—**Emmerson**, Norman, 0404165017009, 2 Ranger Road, Fish Hoek (Simon's Town).—Syfrets Trust, Cape Town.
- 7164/83—**Bruyns**, Helena Adriana, gebore Joubert, 9911130003005, Lombardstraat 6, Wellington (Wellington).—Syfrets Trust, Kaapstad.
- 8010/83—**Turner**, Petro Rita, gebore Van Niekerk, 3508290013001, Hoofstraat, Loeriesfontein (Calvinia).—Syfrets Trust, Kaapstad.
- 6596/82—**Prins**, Maria Cornelia Petronella, gebore Klue, 0206290007007, Edwartstraat 68, Oakdale, Kaapstad (Bellville).—Emile Cloete, Parow.
- 8481/83—**Phillips**, Sophia, formerly Ford, born Hendricks, 2907200019010, 9 Jordan Street, Manenberg (Wynberg).—T. J. Snitcher, Cohen & Snitcher, Cape Town.
- 4515/73—**Kalu**, Jack Birch, 800030959A, Grassy Park, Amended First and Final; Johanna Petronella Jacoba Kalu, 022683752K (Wynberg).—C & A. Friedlander, Cape Town.
- 6901/68—**Holland**, James William, 022297390M, 4 August Street, Cape Town, Third Amended; Johanna Ellen Holland, born Haylett.—Francis Thompson, Ince & Wood.
- 2533/83—**O'Neill**, George Edward Ignatius, 3705095049004, Beach Road, Mouille Point.—Abe Swersky & Associates, Cape Town.
- 398/84—**Davis**, Rose Yetta, born McCarthy, Kenilworth (Wynberg).—Pincus Matz & Feinberg, Claremont.
- 1801/83—**Casserley**, Phyllis, 014464982, 38 Sarel Cilliers Street, Parow; Charles Norman Casserley, 2103205043003 (Bellville).—Robert Macleod, Sea Point.
- 6146/82/6C—**Schnugh**, Anna Elizabeth, 1006280034006, 18 De la Haye Avenue, Kenwyn (Wynberg).—Honeyman, Van Gend & Kotze, Claremont.
- 1673/81—**Wilson**, Phyllis Margaret, 2012060013102, 3 Main Road, Green Point.—Buirski Herstein & Ipp, Cape Town.
- 544/83—**Brophy**, Patric Albert, 2405265052018, 229 Belgravia Road, Crawford; Elizabeth Marjorie Brophy, born Henry (Wynberg).—C & A Friedlander, Cape Town.
- 4330/83—**Sutherland**, Albert John Rudolph, 0702175043000, Spes Bona, First Avenue, Crawford; Iris Mary Sutherland (Wynberg).—Sonnenberg Hoffmann & Galombik, Cape Town.
- 6206/72—**Hendricks**, Achmat Sadick (Sidick), 007152431M, 10 Ayrshire Street, Crawford, Amended First and Final (Wynberg).—Balsillie Watermeyer & Cawood, Cape Town.
- 4845/83—**Grant**, Marie Lydia, 9105090008002, 23 Whitehall Court, Main Road, Rondebosch, First (Wynberg).—Dichmont & Dichmont, Cape Town.
- 6717/83—**Venier**, Natalina, 0512190033005, 3 The Mendips, High Level Road, Sea Point.—Kessel Feinstein Bloch, Cape Town.
- 4089/83—**Lawrence**, Gertude, 9 Park Road, Woodstock, Cape Town.—I. Hoberman, Cape Town.
- 3412/53—**Barnardo**, Christian, Simon's Town (Simon's Town).—Fairbridge, Arderne & Lawton, Cape Town.
- 5498/82—**Knigge**, Erich Adolf Herbert Heinrich, 1108125005009, 502 Aspley House, Main Road, Green Point, Supplementary; Emilie Knigge, 959015763W.—Dichmont & Dichmont, Cape Town.
- 8899/83—**Hughes**, Myrtle, 2209130068104, Parow (Goodwood).—Herold Gie & Broadhead, Cape Town.
- 320/84—**Butler**, Johannes Abraham, 0611035015001, 603 Cinnabar, Main Road, Muizenberg; Catharina Butler (Simon's Town).—Syfret Godlonton-Fuller Moore Inc., Cape Town.
- 2957/83/3D—**Duncan**, Mervyn James, 1301255004005, Dunrobie, Fairview Road, Constantia (Wynberg).—Honeyman, Van Gend & Kotze, Claremont.
- 1436/82—**Gabriel**, Douglas Ronald, 3110075066013, 27 Duck Road, Grassy Park; Helen Maria Gabriel (Wynberg).—Abe Swersky & Associates, Cape Town.
- 8226/83—**Pretorius**, Martinus Stephanus, 2202255010001, 6 The Grove, Leisure Isle, Knysna (George).—Syfrets Trust, Port Elizabeth.
- 1811/84—**Botha**, Christo, 3104265020005, St Paulstraat 74, George; Carolina Maria Botha, gebore Voigt, 3905120007007 (George).—Volkskastrust, Kaapstad.
- 1424/84—**Mocke**, Nicolaas Lourens, 0909015016001, Van Riebeeckstraat 58a, Barrydale; Beryl Daphney Mocke, 1709200011000 (Swellerdam).—Volkskastrust, Kaapstad.
- 1597/84—**Schreuder**, Hester, 019615729W, Agtste Laan 45, Kleinmond; Willem Adriaan van Jaarsveld Schreuder, 0605185017007 (Caledon).—Volkskastrust, Kaapstad.
- 528/84—**Le Grange**, Susanna Petronella, gebore de Ridder, 086591771W, Montaguestraat 66, Mosselbaai (Mosselbaai).—Boland Bank, George.
- 127/84—**Lotz**, Anna Sophia, gebore Muller, 2604230008002, Bosbelhof 29, Bellville; Jacobus Lodewicus Lotz, 2306115005000 (Bellville).—Santamtrust, Bellville.
- 657/84—**Knoetze**, Mathys Johannes, 1704245034000, Piet Retiefstraat 76, Parowallei (Bellville).—Santamtrust, Bellville.
- 1594/84—**Loxton**, Gen, 2402265034013, Marsweg 20, Sydneyvale, Bishop Lavis; Elizabeth Loxton, voorheen Klein, gebore Daniels, 2904260031019 (Bellville).—Santamtrust, Bellville.
- 2670/84—**Keyser**, Christian Jacobus, 0905115028003, Hollandstraat 14, Kraaifontein; Beatrix Susanna Margrietha Keyser, gebore Volschenk, 1401090040006 (Bellville).—Santamtrust, Bellville.
- 307/84—**Rademeyer**, Aletta Magdalena, gebore De Koker, 1301050025007, Huis Uitsig, Merothmanstraat, Parow (Bellville).—Santamtrust, Bellville.
- 1149/83—**Hanekom**, Wouter Johannes Theron, 9701065005005, Ons Huis, Citrusdal (Clanwilliam).—Stone & Bresler, Citrusdal.
- 8812/83—**Kriel**, Jacobus Francois Daniel, 0207125005000, Van Zylstraat 2, Robertson (Robertson).—Muller Baard & Conradie, Robertson.
- 8235/83—**Retief**, Johanna Jacomina, gebore Mocke, 0701270042008, Zerilda Steyn Ouetehuis, Pinelands, Eerste; Pieter Martinus Retief (Goodwood).—G. J. Roux van Marais Müller, Bellville.
- 1536/84—**Visser**, Johannes Petrus, 1401275019007, Sir David Bairdrylaan 44, Bloubergstrand.—Mev. F. Visser, Bloubergstrand.
- 4388/83—**Taylor**, Ronald Herrick, 2011065052107, 7 Lismore Terrace, Greenpoint, Cape Town; Agnes Cecilia Taylor, born Wigmore, 1405050041003 (Cape Town).—Bester, Cooper, Grove & Wolfaard, Cape Town.
- 4183/83—**Nieuwoudt**, Nicolaas Johannes, 0910025009002, Rooseveltstraat 8, Paarl; Hester Woutrina, gebore Du Toit, 0009020013000 (Paarl).
- 4673/83—**Nieuwoudt**, Hester Woutrina, 0009020013000, Rooseveltstraat 8, Paarl (Paarl).—Die Randse Trust Maatskappy, Marshalltown.
- 8261/83—**Leth**, Audrey Joyce, 2912050060007, 149 Lympleigh Road, Plumstead; Frederick Cyril Leih, 2402255030005 (Wynberg).—Standardtrust, Kaapstad.
- 206/84—**Kotze**, Frederik Gideon Albertus, 2205165022008, Dwarskerbos, Veldrif; Johanna Aletta Maria Kotze, 2610310052000 (Laaiplek).—Standardtrust, Kaapstad.
- 13/83—**Neumann**, Karl August Otto Alphons (Alfons) Kurt, 0109295009004, Kusweg 18, Gansbaai, Aanvullende (Hermanus en George).—Standardtrust, Kaapstad.
- 1331/84—**Lategan**, Maria Elizabeth, gebore Van Tonder, 2901240041001, Bergrivier Boulevard 121, Paarl; Alwyn Nicolaas Lategan, 2308075014006 (Paarl).—Standardtrust, Kaapstad.

- 8738/83—**Welch**, Gwendoline Maud, 990980013009, 53 Culumborg Flats, Forest Drive, Pinelands (Goodwood).—Standardtrust, Cape Town.
 8951/83—**Kampfraath**, Sophia Wilhelmina, 022406296W, Mount Villa, Copeland Road, Rondebosch (Wynberg).—Standardtrust, Cape Town.
 265/84—**Cooke**, Robert John, 8906235001005, 4 Ainsworth Crescent, Somerset West; Una Cooke (Somerset West).—Standardtrust, Cape Town.
 2282/84—**Marais**, Gert Frans, 0610255023800, Dirkie Uysstraat 5, Goodwood; Anna Margaretha Rebellina Marais (Goodwood).—Standardtrust, Kaapstad.
 8032/83—**Bowley**, May Fimette, 9804100009006, 17 Anderson Close, Tokai (Wynberg).—Standardtrust, Cape Town.
 8681/82—**Van Gass**, Yvonne Madeleine, 3002120001006, Gansfontein, Fraserburg; Nicolaas Jacobus van Gass, 2904095003001 (Fraserburg).—Standardtrust, Kaapstad.
 6397/83—**Human**, Johannes Albertyn, 4110065020003, Modder Valley, Bredasdorp (Bredasdorp).—Standardtrust, Cape Town.
 4855/83—**Wilson**, Lillian Shannon, 0109270019002, 9 Montreaux, Queen Victoria Street, Cape Town.—Standardtrust, Cape Town.
 2583/84—**Rauch**, Neville Claud Denis, 2812115045003, 89 Newton Drive, Meadowridge, Cape Town; Madeleine Mary Theresa Rauch, born Fryer, 3509400240009 (Wynberg).—Standardtrust, Cape Town.
 1484/84—**Donnelly**, Margaret Mary, 5108100102009, 106 Leeukop, Gilmourhill Road, Tamboerskloof, Cape Town.—Standardtrust, Cape Town.
 8332/83—**Goosen**, Johannes Cornelius, 0401265016006, Rhonestraat 12, Paarl; Anna Jacomina Goosen, gebore Victor, 096741227W (Paarl).—Standardtrust, Kaapstad.
 7526/82—**Johnson**, Victor George Ernest, 0511275021000, 3 Windsor Mansions, Lulworth Road, Rondebosch (Wynberg).—Standardtrust, Cape Town.
 90/84—**Belton**, Mary Kathleen, 959013421W, Glenlea Residence, Breda Street, Gardens, (Wynberg).—Standardtrust, Cape Town.
 2107/84—**Lotz**, Andre Pierre, 5604245011006, Papawerstraat 18, Blomtuin, Bellville; Hanlie Nerina Lotz, 5910090049003 (Bellville).—Standardtrust, Kaapstad.
 8366/83—**Smith**, Anna Elizabeth, 0911240011005, Voortrekkerstraat 17, Vredenburg; Jacobus Johannes Petrus Smith, 0912235026008 (Vredenburg).—Standardtrust, Kaapstad.
 2382/84—**Eaplin**, Felicité Constance, 2106090016000, 64 Jeffcoat Avenue, Bergvliet (Wynberg).—Standardtrust, Cape Town.
 4090/83—**Maddock**, Sameul Joseph Allen, 2111105038007, 30 Achilles Way, Pinelands (Goodwood).—Standardtrust, Cape Town.
 2312/84—**Smith**, Maria, 086578802K, 20 Nimbus Way, Elfindale, Heathfield; David Robert Percy Smith, 2110065084019 (Wynberg).—Standardtrust, Cape Town.
 652/83—**Davies**, Joan Hoskyn, 0912020023004, 6 Gardenia Avenue, Devils Peak.—Standardtrust, Cape Town.

NOORD-KAAP • NORTHERN CAPE

By die kantoor van die Meester, **KIMBERLEY**, en ook van die landdros van die distrik wanneer dit tussen hakies gemeld word.

At the office of the Master, **KIMBERLEY**, and also of the magistrate of the district when stated in parentheses.

- 62/84—**Scheepers**, Jacobus Lourens, 1510075034006, Ramanskolk, Kakamas; Hendrina Jacoba Magrieta (Magrietha) Scheepers, 2009110039004 (Kakamas).—Joubert Blaauw & Le Roux.
 316/84—**Van den Berg**, Stephen, 0808055001008, Herculesstraat 29, Beaconsfield, Kimberley; Susanna Johanna Petronella van den Berg, gebore Anderson, 1507110001008.—Santamtrust, Bloemfontein.
 351/84—**Botha**, Gideon Johannes, 4809295127005, Bosshoffsingel 21, Vryburg; Lorraine Botha, gebore Kapp (Vryburg).—Santamtrust, Bloemfontein.
 358/82—**Van Zyl**, Antonette, 3412180012001, Damfontein, De Aar (De Aar).—Johan M. Swiegers & Kie, De Aar.
 68/84—**De Wit**, Matthys Jacobus, 1309225014006, Presidentstraat 1, Parkheuvel, Hopetown; Alida Johanna Petronella de Wit (Hopetown).—Elliott Maris Wilmans & Hay, Kimberley.
 821/83—**Myburgh**, Willem Albertus, 9204115001009, Osbornestraat 23, Kimberley.—De Villiers & Bredenkamp, Griekwastad.
 205/84—**Bothomley**, Clifford Tildesley, 0105275003009, 32 Synagogue Street, Kimberley.—Standardtrust, Kimberley.
 1003/83—**Kruger**, Johannes Petrus Cornelius, 2003235036003, Huis 69, Lohathla (Postmasburg).—Viljoen & De Beer, Postmasburg.
 1203/83—**Jansen van Vuuren**, Esias Engelbertus, 3001045005001, Leonardstraat, Danielskuil; Aletta Christina Jansen van Vuuren, 2909280008004 (Postmasburg).—Standardtrust, Kimberley.
 1002/83—**Jansen**, Victor Gerald, 4012245103016, 17 Carnation Avenue, Kimberley; Eileen Rose Jansen, 4409170087018.—Syfrets Trust & Executor, Kimberley.
 915/82—**Nel**, Gert Johannes, 3708225013007, Perseel 6 I 11, Hartswater (Hartswater).—Harrison, Marais & Mostert, Christiana.
 1206/83—**Rykheer**, Cecilia, 1304230040003, Schroder, Pk. Kakamas; Daniel Antonius Rykheer, 1801305002008 (Kakamas).—J. A. Loubser, Kakamas.
 889/83—**Van der Walt**, Jacobus Lukas, 1207235025004, Middeldag, Strydenburg (Hopetown).—Standardtrust, Kimberley.
 17/83—**Geyser**, Hendrik Johannes, 3805075049006, Halestraat 11, Pomfret; Hester Maria Geyser, gebore Le Roux, 4306230096007 (Vryburg).—Du Plessis Viviers & Kie., Vryburg.
 84/84—**Hyman**, Rachel Petronella, 0011150019005, Lentehofwoonstelle 6, Upington (Upington).—Lange Joubert Carr & Blaauw, Upington.
 821/83—**Myburgh**, Willem Albertus, 9204115001009, Osbornestraat 23, Kimberley.—De Villiers & Bredenkamp, Griekwastad.
 798/83—**Smith**, Cornelius Johannes, 9105175002003, Wiidspan, Postmasburg (Postmasburg).—Volkskastrust, Kimberley.
 817/83—**Van der Walt**, Jacobus Andries, Rooslaan 42, Kuruman; Douwina, Gertbrecht Susanna van der Walt (Kuruman).—Jordaan & Van Tonder.

OOS-KAAP • EASTERN CAPE

By die kantoor van die Meester, **GRAHAMSTAD**, en ook van die landdros van die distrik wanneer dit tussen hakies gemeld word.

At the office of the Master, **GRAHAMSTOWN**, and also of the magistrate of the district when stated in parentheses.

- 1610/83—**Nell**, Dinah Johanna Wilhelmina, gebore Hay, Crosstraat 27, Uitenhage (Uitenhage).—Marais Müller, Bellville.
 1842/83—**Miller**, Isabel Ellen, born Smith, 967013403, widow, 16 Towpath, Redhouse, Port Elizabeth (Port Elizabeth).—Oosthuizen, Hazell & Wilmot, Port Elizabeth.
 486/84—**Janse van Rensburg**, Johannes, 1304155001006, Mackaystraat 56, Sentraal, Port Elizabeth; Catherina Elizabeth Johanna Magrietha Janse van Rensburg, gebore Welgemoed 3201170003009 (Port Elizabeth).—Harding Pretorius & Kie., Port Elizabeth.
 2585/83—**Pitt**, Kenneth Owen, 1012075009005, 3 Poplar Avenue, Chiselhurst, East London; Avis Rose Pitt, formerly McKowen, born Wood, 1711200036003 (East London).—Wakefield Houzet & Burmeister, East London.
 1809/62—**Du Preez**, Johanna Maria, Vincentweg 103, Oos-Londen, Gewysigde (Oos-Londen).—Volkskastrust, Port Elizabeth.
 1721/83—**Lemmer**, Andrisina Delina, gebore Oelofse, 2107170079009, Honingklip, distrik Steytlerville (Steytlerville).—Standardtrust, Port Elizabeth.
 2169/84—**Van Eck**, Willem Rudolph, 1709205006005, Knysnastraat, Willowmore; Catharine Johanna van Eck, 1207170039002 (Willowmore).—Volkskastrust, Port Elizabeth.
 906/84—**Van Huyssteen**, Nicolaan Cornelius, 3304095061001, Bramptonlaan 13, Rowallan Park, Port Elizabeth; Emmerentia Wilhelmina van Huyssteen, 8302060052004 (Port Elizabeth).—Volkskastrust, Port Elizabeth.
 702/83/2A—**Leverment**, Joseph Barney, 1107315034019, 10 Adam Street, Queenstown; Mary Connell Leverment, 1408130038015 (Queenstown).—Theodore Vorster, Fort Beaufort.
 180/84—**Davis**, Johanna Aletta, 3203300044002, Francisstraat 58, Somerset-Oos; Frederik Willem Davis, 24030150605006 (Somerset-Oos).—Scott, Stegmann & Farr, Somerset-Oos.

- 676/84—**Irmscher**, Mavis Lilian Martha, 190329008006, 12 Gerita Mansions, 62 St George's Road, East London; Ronald Oscar Irmscher.—Standardtrust, East London.
- 3592/83/2A—**King**, Alice Albertine, 100199284W, 9 Netley Road, Perridgevale, Port Elizabeth (Port Elizabeth).—Hutton & Horn, Port Elizabeth.
- 3857/81—**Purdon**, Ronald Austin, 1401115010000, Springfield, District of Bathurst, Amended First and Final.—Dold & Stone, Grahamstown.
- 2500/83—**Botcher**, Ernst Carl August, 9112135001000, Casa Mia, St Peters' Road, East London (East London).—Hutton & Cook, King William's Town.
- 714/84—**Puttergill**, Henry William, 0802275023009, 4 Chambers Crescent, Gonubie; Elizabeth Blanche Puttergill, born McClelland (East London).—Standardtrust, East London.
- 3514/82—**Brooker**, Arthur Sydney, 1603085053007, Laubscher Parktehuis, Walmer, Port Elizabeth; Ruth Jean Brooker, gebore McKay (Port Elizabeth).—P. C. van Staden Venter & Kie., Port Elizabeth.
- 1976/83/2A—**Brown**, Maisie, 0911090021005, 4 Bryson Street, King William's Town (King William's Town).—Hutton & Cook, King William's Town.
- 2062/83—**Naude**, Jacob Johannes, 2706085051001, 26 Curtis Road, Amalinda, East London; Johanna Maria Naude, born Shaw, 2906100055009 (East London).—R. A. Allam, East London.
- 3308/83/2C—**Penrith**, Bernard Braithwaite, 3411155023001, 5 Bibury Avenue, Linkside, Port Elizabeth; Elgene Elizabeth Penrith, 3501120027002 (Port Elizabeth).—Pagden, Christian, Hanley & Parkin, Port Elizabeth.
- 1451/83—**Stanford**, Elizabeth Monica Hazel, born Kennett, 4 Highbury Terrace, East London, Supplementary (East London).—Drake Flemmer Orsmond & Vermaak, East London.
- 21/84—**Strydom**, Joyce, gebore Chamberlain, Bartonweg 3, Cotswold, Port Elizabeth (Port Elizabeth).—Volkskastrust, Port Elizabeth.
- 3657/83—**Bosch**, Johannes Christiaan, 3612025017004, Langebergweg 15, Queenstown; Lynette Bosch, gebore Marais, 4011220016003 (Queenstown).—Volkskastrust, Port Elizabeth.
- 4/84—**Coetzee**, Lionel, 6303275217018, 20a Reynecke Street, Gelvandale, Port Elizabeth (Port Elizabeth).—Eugene Peffer & Company, Port Elizabeth.
- 816/84—**Malherbe**, Anna Salomina, 5712240037007 (Murraysburg).—Volkskastrust, Port Elizabeth.
- 3249/83—**Landman**, Alexander, 1012115019006, Rhu Allen, Posbus 37, Hankey; Martha Jacoba Magdalena Landman, 055307088WL (Hankey).—Volkskastrust, Port Elizabeth.
- 3615/83—**De Beer**, Anna Sophia, gebore Du Randt, 0308010023007, Dirk Postma-ouetehuis 15, President Swartweg, Burgersdorp (Burgersdorp).—Barclays-Nasionale Bank, Oos-Londen.
- 353/81/1A—**Franks**, Aubrey Louis, 2301175062019, 14 Inxu Street, Ugie (Maclear).—Wade & Hills, Maclear.
- 1122/83—**Greyvenstein**, Johannes Diederick, 1205095020008, Erin, Dordrecht; Cecilia Johanna Jacobus Greyvenstein, gebore Schoeman, 1301100016006 (Dordrecht).—Barclays-Nasionale Bank, Oos-Londen.
- 189/84—**Pringle**, William, 1304105046002, 79 15th Avenue, Gonubie (East London).—Barclays National Bank, East London.
- 266/83—**Van Rooyen**, Martha Helena, gebore Sauer, 0105020015001, Nerinahof, Dordrecht (Dordrecht).—Barclays-Nasionale Bank, Oos-Londen.
- 314/84—**De Kock**, Alice Birrel, born Watson, 0509090013004, Stirling Lodge, Epsom Road, Stirling, East London (East London).—Santamtrust, Cape Town.
- 357/84—**Blandford**, Horace Samuel, 2011135033004, 142 Fordyce Road, Walmer, Port Elizabeth; Eunice Mary Blandford, 2502140030001 (Port Elizabeth).—A. W. Pudney & Son, Port Elizabeth.
- 974/84—**Vorster**, Jacobus Munro, 1503065016000, Cullean, Thomas River; Emmarentia Aletta Vorster, 2602240024001 (Cathcart).—Santamtrust, Port Elizabeth.
- 880/84—**Erasmus**, Peter William, 3210085045005, 35 Hampstead Avenue, Greenfields, East London; Maria Susanna Katrina Erasmus, born Kruger, also known as Maria Katrina Sussanna Erasmus, 3511180011002 (East London).—Santamtrust, Port Elizabeth.
- 481/84—**Myburgh**, Petrus Johannes, 5101015094007, Frankenburgstraat 13, Uitenhage; Elna Myburgh, gebore Terblanche, 5306240084000 (Uitenhage).—Santamtrust, Port Elizabeth.
- 1077/84—**Finch**, George Harold, 1603165054008, Woonstel 3, Echovale, Aragonweg, Port Elizabeth (Port Elizabeth).—Santamtrust, Port Elizabeth.
- 291/84—**Simon**, Josephine Magdalene, born Cornelissen, 4003240043018, 45 Kobus Road, Gelvanpark, Port Elizabeth (Port Elizabeth).—R. D. Simon, Port Elizabeth.
- 724/84—**Du Plessis**, Pieter Daniel, 3009275052007, Allisonstraat 12, Uitenhage; Janetta Magrieta (Jeanette Magrietha) du Plessis, gebore Deyzel, 3206230037004 (Uitenhage).—Santamtrust, Port Elizabeth.
- 969/84—**Fourie**, Reginald Philip, 3810315033000, Essenhighweg 2, Adcock Uitbreiding, Port Elizabeth; Aletta Petronella Fourie, gebore Gerber, 3805280062000 (Port Elizabeth).—Santamtrust, Port Elizabeth.
- 706/84—**Van Zyl**, Susanna Johanna Maria, 3804260026002, Emily Hobhousestraat 2, Despatch; Johannes Abram Lawrence van Zyl, 3204265040001 (Port Elizabeth).—Santamtrust, Port Elizabeth.
- 585/84—**Louw**, Hendrik Amos Albertus, 4304095078004, Kerkstraat 76, Despatch; Maria Johanna Louw, gebore Croeser, 4306100067005 (Uitenhage).—Santamtrust, Port Elizabeth.
- 497/84—**Friebe**, Bruno Alfred, 3309185091107, Poplarstraat 22, Uitenhage; Issie Stoffelina Friebe, gebore Serfontein, 4106260004008 (Uitenhage).—Santamtrust, Port Elizabeth.
- 349/84—**Nelson**, Collin, 5706245075004, Prince Alfred Park, Noordeinde, Port Elizabeth; Hester Johanna Nelson, gebore Els, 6006010232008 (Port Elizabeth).—Santamtrust, Port Elizabeth.
- 261/84—**Taljard**, Jennifer Yvonne, 4503010040003, 44 Avalon Road, Beacon Bay, East London; Cornelius Jansen Philippus Taljard, 4205245051009 (Oos-Londen).—Santamtrust, Port Elizabeth.
- 1189/84—**Taylor**, Fred Nathaniel Richard, 1504245014006, Flat 4, 96 St Pauls Road, East London (East London).—Santamtrust, Port Elizabeth.
- 840/84—**Booker**, Cecil, 3206115054009, 33 Eastbourne Road, Central, Port Elizabeth; Magdalena Catherina Booker, born Williams, 3907220041001 (Port Elizabeth).—Santamtrust, Port Elizabeth.
- 893/84—**Gericke**, Barend Jacobus, 1108275013001, Fouriestraat 12, Despatch; Magdalena Catharina Gericke, gebore Jansen van Vuuren, 1905300014007 (Uitenhage).—Santamtrust, Port Elizabeth.
- 914/82—**Farrell**, Frederick William, 0903245028001, 67 Wodehouse Street, Queenstown, Second Liquidation and Distribution; Dulcie Mavis Farrell, formerly Abbott, born Diemer, 0507050010002 (Queenstown).—Standardtrust, East London.
- 1128/84—**Michau**, Johanna de Villiers, gebore Nortje, 3611090004004, Kollegeweg 1, Cradock (Cradock).—Santamtrust, Port Elizabeth.
- 528/84—**Van der Byl**, Glynis Joyce, 5802100033004, 32 Third Street, St George's, Strand, Port Elizabeth, First (Port Elizabeth).—Santamtrust, Port Elizabeth.
- 442/84—**Souter**, Alfred Grant, 0810275020107, Aragon Hof 6, Aragonweg, Adcockvale, Port Elizabeth (Port Elizabeth).—Santamtrust, Port Elizabeth.
- 1081/84—**Naude**, Johannes Carolus, 2310115063001, Rhodesstraat 49, Mount Pleasant, Port Elizabeth; Contance Fiona Naude, gebore Crichton, 4101200040006 (Port Elizabeth).—Santamtrust, Port Elizabeth.
- 1960/83—**Le Roux**, Joseph Francois, 4411265092002, Jan Smutslaan 69, Greenfields, Oos-Londen, Suplementêre Likwidasie en Distribusie (Oos-Londen).—Standardtrust, Oos-Londen.
- 2075/83—**Robinson**, Claude, 1009105039002, 9 Kettlewell Road, Amalinda, East London; Florence Grace Robinson, born Pullin, 2211200046002 (East London).—Standardtrust, East London.

- 2488/83—**Kathan, James Sandon**, 1012015044054, 189 Mountview Drive, Malabar, Port Elizabeth; Rashal Rosie Kathan, 1011240034054 (Port Elizabeth).—Price Soni & Friedman, Port Elizabeth.
- 1114/83—**Avis, Archibald**, 1406255021006, Thornhill Farm, P.O. Hilldasia (East London).—Standardtrust, East London.
- 3040/83—**Van Zijl, Pieter Carel Moller**, born Barnard, 0306060037000, Kareedouw, Cape (Humansdorp).—Barclays National Bank, Port Elizabeth.
- 3641/83—**Vanderveken, Marc Jean Marie Adelin Ghislain**, 3402065085107, 156 Heugh Road, Walmer, Port Elizabeth (Port Elizabeth).—Barclays National Bank, Port Elizabeth.
- 2807/83—**Barnard, Catharina Albertha**, 1907090041000, Forest View, Stutterheim; Adam Johannes Barnard, 1409305014005 (Stutterheim).—Volkskastrust, Port Elizabeth.
- 3653/83/1B—**Olivier, Gabriël Johannes**, 0311285003001, Kerkstraat 22, Jansenville (Jansenville).—Volkskastrust, Port Elizabeth.
- 831/84/1C—**Lehmann, Gertruida Jacoba**, 1410110020005, Graaff-Reinet; Johann Jubilee Lehmann, 1610205022005 (Graaff-Reinet).—Volkskastrust, Port Elizabeth.
- 3304/82/2A—**Van Vuuren, Kenneth Noel**, 5412255156004, Du Preezstraat 16, Sidwell, Port Elizabeth; Joan Louisa Maria van Vuuren (Port Elizabeth).—Heyns & Prinsloo, Port Elizabeth.
- 910/84—**Terblanche, Eugene Cedric**, 6411165090005, Brockweg 36, Kensington, Port Elizabeth (Port Elizabeth).—Volkskastrust, Port Elizabeth.
- 3268/83—**Daverin, Dorothea Maria**, born Van Rooyen, 0109050005007, 8 Allen Avenue, Abbotsford, East London; Hugh Patrick Daverin (East London).—Syfrets Trust, East London.
- 895/84—**Krain, Fritz Christian**, 2011125032008, Gardiniaweg 32, Uitenhage; Joyee Yvonne Krain, gebore Properjohn, 2410280031005 (Uitenhage).—Santamtrust, Port Elizabeth.
- 2979/83—**Samuels, Johanna Christina**, 1509160074018, Stanfordweg 180, Korsten, Port Elizabeth; Johanna Christina Samuels, voorheen Jacobs, gebore Oktober, 1509160074018 (Port Elizabeth).—Santamtrust, Port Elizabeth.
- 743/84—**Gouws, Daniel Franciscus**, 0301045008002, Voortrekkerweg 6, Despatch (Uitenhage).—Santamtrust, Port Elizabeth.
- 210/81—**Clarke, Stanley Michau**, 9104255005002, Hofmeyr, Amended First and Final (Hofmeyr).—Metcalf & Co., Cradock.
- 3122/83/2A—**Roller, Edward**, 2002275040008, Windsor Hotel, Queenstown (Queenstown).—Du Randt & Louw, Kroonstad.
- 201/84/1B—**Date Chong, Moi Fook**, 2105035066047, 138 Durban Road, Korsten, Port Elizabeth; Mee Yen Date Chong, born Woon (Port Elizabeth).—Hutton & Horn, Port Elizabeth.
- 2514/83—**Odell, Dorine Clarice**, 9508030004009 (East London).—Langstaffe Bird & Company, Johannesburg.
- 3609/83—**Grahamstown, Margaret Ethel**, 2206080047005, 19 Dove Road, Greenshields Park, Walmer, Port Elizabeth; John Robert Elliott, 2306165044008 (Rodepoort).—Barclays National Bank, Johannesburg.
- 843/84—**Olivier, Daniel Du Preez**, 2803135022007, Jansenweg 49, Despatch; Edna May Olivier, gebore Knoetze, 3506230030002 (Uitenhage).—Volkskastrust, Port Elizabeth.
- 2305/83/1C—**Brown, Doreen Patricia**, 2511060028002, Erf 33, Sunrise-on-Sea, District of East London (East London).—Bate Chubb & Dickson Inc., East London.
- 3173/83—**Frost, Constance**, formerly O'Donnell, born Riley, 9502190005005, St Joseph's Hospital, Park Drive, Port Elizabeth (Port Elizabeth).—Syfrets Trust, Port Elizabeth.

NATAL

By die kantoor van die Meester, PIETERMARITZBURG, en ook van die landdros van die distrik wanneer dit tussen hakies gemeld word.
At the office of the Master, PIETERMARITZBURG, and also of the magistrate of the district when stated in parentheses.

- 6653/83—**Harper, Robert Loyal**, 1302035039006, 12 Glenallan, 121 King Edward Avenue, Pietermaritzburg. —Barclays National Bank, Pietermaritzburg.
- 796/83—**St Joseph, Neville William**, 2101145043000, 9 Eldorado Place, Pietermaritzburg, Supplementary. —Barclays National Bank, Pietermaritzburg.
- 1221/84—**Sproule, William Gosset**, 1009185043007, Weza, Kokstad (Kokstad). —Barclays National Bank, Pietermaritzburg.
- 3996/83—**Lewis, Ivor Dudley**, 2110025007001, 403 Amtoti, 20 Turner Street, Amanzimtoti, Supplementary First and Final Liquidation and Distribution (Durban). —Barclays National Bank, Durban.
- 4920/83—**Rönnebedh, Sten Gösta**, Swedish Diplomat Passport 617, 53 Outhie Street, Karori, Wellington 5, New Zealand, Supplementary First and Final (Pinetown). —Barclays National Bank, Durban.
- 2970/83—**Conradie, Jean Elizabeth**, 1902100015003, 6 Speirs Road, Ladysmith (Ladysmith). —Barclays National Bank, Pietermaritzburg.
- 7112/83—**Goble, Phyllis Dorothy**, 0006240013004, 8 Gloucester Road, Clarendon, Pietermaritzburg. —Barclays National Bank, Pietermaritzburg.
- 3675/82—**Vermaak, Gerhard Jacobus**, 0203215005000, Valley Street, Weenen (Weenen). —Barclays National Bank, Pietermaritzburg.
- 5861/83—**McDonald, Ronald Robert**, 2808255047007, 3 Duncan Grove, Pinetown (Durban). —Meuman & White, Durban.
- 6118/83—**Verbruggen, Willem**, 1403105037100, Huis 119, Village of Happiness, Margate; Antje Verbruggen, gebore Wybregt (Margate). —Van der Walt & Hugo, Pretoria.
- 1082/84—**Coulthard, Florence**, USA Passport Z3151158 (Durban). —Clemmans & Johnston Inc., Durban.
- 2203/84—**Padayachi, Muniamma**, 4209170094059, 19 Greenvale Avenue, Westcliff, Chatsworth; Munsami Padayachi, 3706205015058 (Chatsworth). —Moolla & Singh, Durban.
- 2100/84—**Ramthal, Minawathi**, 3402020066051, 35 Road 902, Chatsworth, Durban, predeceased (Chatsworth). —Moolla & Singh, Chatsworth.
- 3384/82—**Ramsamy, 800466923**, Glendale, Lower Tugela (Stanger). —Dhana Naidoo & Co., Stanger.
- 6567/83—**MacMillan, Ian Maxwell**, 1510225006003, 12 Oxford Drive, Durban North (Durban). —P. G. Johnson, Glenashley.
- 5238/83—**Millar, Eileen Bruce**, 9712110017002, 35 Howick Drive, Waterfall (Pinetown). —A. D. Millar & Kimber, Durban.
- 1022/83—**Govindsamy (Govender)**, 4611105133052, 70 Swan Road, Duff's Road Township (Durban). —Mooney, Ford & Partners, Durban.
- 6879/83—**McCallum, Fergus MacAndrew**, 0001145005003, 33 Mount Vernon Road, Hillary; Frances Nellie McCallum (Durban). —Mooney, Ford & Partners, Durban.
- 6370/82—**Marimuthu, 800462103A**, 220 Chatsworth Main Road, Umhlatuzana, Chatsworth; Pullammah, 2405150072055 (Chatsworth). —J. P. Maharaj, Durban.
- 5099/83—**Crookes, Victor Joshua Samuel**, 0008305007000, Balgowan, Natal, First Liquidation (Howick). —Deloitte Haskins & Sells, Durban.
- 933/84—**Russell, Lavinia Beryl**, 9206130004009, 63 Everton Road, Kloof, First (Pinetown). —Lester Hall Ewing & Swan, Hillcrest.
- 1282/83—**Maytham, Edith Gertrude Mary**, 97110200041 (Durban). —Hathorn & Fannin, Durban.
- 6085/83—**Juby, Cecil Vivian**, 1402105059007, 24 Willowvale Hotel, Umbilo Road, Durban (Durban). —C. C. Brunton, Durban.
- 5677/83—**Adcock, Iris Eleanor Christina**, 1006070037003, 5 Somerset, 530 Currie Road, Durban (Durban). —Clive Henry de Beer, Durban.
- 5942/83—**Carr, Myee Marjorie**, 1502210028001, 56 Kentucky Drive, Virginia, Durban North (Durban). —Chapman Dyer Inc., Durban.
- 592/84—**Adam, David Lloyd**, 0107085015009, Glamis Nursing Home, Florida Road, Durban (Durban). —Syfrets Trust, Durban.
- 1234/84—**Heyneke, Jan Christoffel**, 4109115027000, 4 Falcon Place, Cowies Hill, Pinetown; Adriana Heyneke, 4710150036002 (Pinetown). —Santamtrust, Durban.
- 1744/83—**Hopkins, Walter Crofton**, 0907155017003, 78 Pearson Road, Everton, Second and Final (Pinetown). —Lester Hall Ewing & Swan, Hillcrest.
- 1140/84—**Sewnarain, Ramchunder**, 2806255043059, 6 McLarty Road, Reservoir Hills, Durban; Leelapathee Sewnarain (Durban). —Syfrets Trust, Durban.
- 562/84—**McDonald, Helen**, 0311010017003, 60 Jameson Crescent, Durban (Durban). —Syfrets Trust, Durban.

- 6300/83—**Lloyd-Clayton**, Samson Whiteley, 0611175034002, 49 Harborth Road, New Germany; Audrey Isabel Lloyd-Clayton (Pinetown).—Palmer's Trust, Durban.
- 1993/84—**Naidu**, Nariansamy Ramanujam, 3408025093057, 316 Silver Glen Drive, Silver Glen; Ponnammal Naidu, 4106050108050 (Durban).—J. H. Nicolson Stiller & Geshen, Durban.
- 2889/83—(The Natal Law Society), **Maharaj**, Roopnarain Saibrai, 5307115129052, Flat 3, Eskay Plaza, Hulett Street, Stanger, First (Stanger).—Jay Pundit & Co., Stanger.
- 3150/83—**Dunbar**, Theodorus Olive Stewart-Ross, 2606190022006, 96 Lewis Drive, Amanzimtoti (Durban).—Louis M. Podbielski, Durban.
- 1602/62—**Timol**, Esouf Mahomed, 43 Agnes Road, Durban, Second (Durban).—Zubeda Seedat & Co., Qualbert.
- 4758/83—**Barham**, Edward Victor, 1508065065006, 49 Laurel Road, Durban; Freda Stella Barham (Durban).—Syfrets Trust, Durban.
- 6661/83—**Robertson**, Olive Annie, 0410260016002, 2 Simsley, 19 Bonieux Place, Durban (Durban).—Syfrets Trust, Durban.
- 988/84—**Hamilton**, George Augustus Daniel, 0109275005006, 75 Manhattan Court, 11 Broad Street, Durban (Durban).—Syfrets Trust, Durban.
- 766/84—**Brits**, June Clare, born Coppinger, 3606120030003, 14 Lyngarth Park, Kloof; Gert Nicolas Brits, 3205065040000 (Pinetown).—Santamtrust, Durban.
- 1749/84—**Adlem**, Jan Johannes Christoffel, 2110065013000, 40 Ruby Gailey Drive, Ladysmith; Hester Johanna Adlem, 2801070071005 (Ladysmith).—Santamtrust, Durban.
- 6690/83—**Rahamud**, 800431976A, Emona Farm, Emona, District of Inanda; Kalasi, 8003361163 (Verulam).—Estate late Rahamud, Tongaat.
- 166/84—**Edmonds**, Courtenay Walter Thomas, 9808075008000, c/o Musgrave Nursing Home, Musgrave Road, Durban (Durban).—Garlicke & Bousfield Inc., Durban.
- 7115/83—**Oelofse**, Andries Nicolaas, 6105135032002, Victorialaan 65, Newcastle, Supplementary First and Final (Newcastle).—Santamtrust, Durban.
- 6955/83—**Machin**, Hester Anna, born Swanevelder, 3601100005000, 35 Mearer Road, Ladysmith; Edward William Machin 3108075012003 (Ladysmith).—Santamtrust, Durban.
- 585/83—**Holroyd**, James Taylor, 1206015017009, 1505 Barcelona, Playfair Road, Durban, Second and Final (Durban).—Santamtrust, Durban.
- 1795/84—**Naidoo**, Coopsamy, 800459815, 16 Jawhar Place, Merebank; Rajamma Naidoo, 800319941A (Durban).—Santamtrust, Durban.
- 4853/83—**Moodley**, Soobiah, 800110688A, 47 Bombay Road, Pietermaritzburg; Kanniamah.—Mason Buchan Leslie Weinberg, Pietermaritzburg.
- 6436/82—**Deedat**, Abdul Kadir (Abdul Kadir Ismail Dedat), 2904025065054, 267 Orthmann Road, Pietermaritzburg; Zolaika Bibi Dedat.—Mason Buchan Leslie Weinberg, Pietermaritzburg.
- 6588/82—**Beachen**, Doolathee (Dowlath), 800663251, Mary Street, Ixopo (Ixopo).—Mason Buchan Leslie Weinberg, Pietermaritzburg.
- 697/84—**Fordham**, Alwyne Douglas, 0809095025007, 7 Cheltenham Drive, Widenham, Umkomaas (Scottburgh).—Barclays National Bank, Durban.
- 1060/84—**Lahana**, Stel (Stelianos), 1612015020002, Widenham Caravan Park, P.O. Box 157, Widenham, Umkomaas; Thelma Mabel Lahana, 2206140028003 (Scottburgh).—Barclays National Bank, Durban.
- 1817/84—**Buyle**, Maria Ludivica Fransiska, 1409190045106, 89 Winchelsea Avenue, Wentworth; Julianus Stephanus Buyle, 1310205040100 (Durban).—Barclays National Bank, Durban.
- 315/84—**Scrooby**, Sheila Phyllis, 2403260009000, 30 Main Street, Eshowe (Eshowe).—W. E. White, Eshowe.
- 3767/82—**Johnson**, Alan Prior, 2010145027105, 121 Saratoga, 69 Forest Drive, La Lucia, Supplementary Liquidation and Distribution (Durban).—Cox Yeats & Partners, Durban.
- 996/84—**Morton**, Nora Agnes, 9612120007003, 52 Cromwell Road, corner of Cromwell and Brand Roads, Durban (Durban).—Barclays National Bank, Durban.
- 1264/84—**Freese**, Edith May, 0208220016009, 8 Bryan Place, Durban (Durban).—Barclays National Bank, Durban.
- 2664/83—**Boojhjhawun**, Sewpersad, 800321642, Saswood Road, Glen Anil, Durban (Durban).—C. I. Vawda, Verulam.
- 4306/83—**Moodley**, Narainsamy Manikum, 1901025042050, End of Himalaya Drive, Everest Heights, Verulam; Thralthumbal Subrayan, 3007190087058 (Verulam).—C. I. Vawda, Verulam.
- 1223/84—**Barnard**, Bernard Ian, 3405185078001, 113 Catalina Drive, Hibberdene (Port Shepstone).—Santamtrust, Durban.
- 51/84—**Maharaj**, Deepnarain, 3001045110058, 16 Stockville Road, Gillitts; Banespathee Maharaj (Pinetown).—McClung Goudge & Mustard, Pinetown.
- 6427/82—**Wichmann**, Hermann Friedrich Johannes, 0709075018008, 17 Coghill Street, Dundee, First (Dundee).—R. Dunn, Dannhauser.
- 2356/83—**Carter**, Julian Auchmuty, 3205105005005, Fulton School for the Deaf, P.O. Box 5, Gillitts (Pinetown).—Graham Harrison, Pietermaritzburg.
- 3933/83—**Frederick**, Hilda Alice, San Rachel Nursing Home, Alexandra Road, Pietermaritzburg.—Randles, Davis & Wood, Pietermaritzburg.
- 405/83—**Rochat**, Kenneth Cecil, 381016502008, 16 Philpott Street, Howick, First; Wendy Agnes Rochat, born Glas (Howick).—Randles, Davis & Wood, Pietermaritzburg.
- 4028/73—**Jugdai**, 800335269A, 210 Helston Road, Allandale, Pietermaritzburg, Amended.—Randles, Davis & Wood, Pietermaritzburg.
- 598/84—**McLaurin**, Eric Graham, 3903075048001, 10 Greenfields Place, Merrivale, Supplementary (Howick).—J. Leslie Smith, Pietermaritzburg.
- 6503/83—**McGarry**, Henrietta (Martha Henrietta), 0911150023008, 23 Visagie Road, Grange, Pietermaritzburg; Ivor McGarry.—Mason Buchan Leslie Weinberg, Pietermaritzburg.
- 906/83/3C—**Anderson**, Charles Humphrey, 6108045047003, Dammanstraat 49, Glencoe (Glencoe).—Van Rensburg & Hellberg, Glencoe.
- 1390/84—**Duncan**, Mary Cicely, 9806200006006, Sunnyside Park, Private Bag 9081, Pietermaritzburg.—Nel & Stevens, Greytown.
- 2882/83—**Plevler**, Arnold Christiaan, 4205275001007, Sewendelaan 70, Ashley, Pinetown; Elsie Plevier, 4409020002001 (Pinetown).—Volkskastrust, Pietermaritzburg.
- 5447/83—**Meadows**, William Albert, 0411255017005, 919 Bream Road, Pennington (Scottburgh).—Blamey & Ferguson, Scottburgh.
- 6312/83—**Van Zijl**, Izak Petrus, 1908255025002, Hugost 16, Utrecht; Anna Magdalena Maria van Zijl, gebore Klukow, 2106040064001 (Utrecht).—A. D. Bosman, Wierdapark.
- 1493/82—**Worthington**, Derrick Yorke, 2703125078003, Lyell, Wasbank, Second and Final (Dundee).—Greenhough, McHardy & Jones, Dundee.
- 448/84—**File**, Joyce Emily, 0303240004000, 56a Francis Road, Ladysmith (Ladysmith).—E. B. Howard, Ladysmith.
- 3647/83—**Cordes**, Winifred Mary, 211458443W, widow, 2 Glenearn Road, Overport, Durban (Durban).—Goodrickes Attorneys to Executor, Durban.
- 4324/80—**Horner**, Basil Clement, 2807225026000, Elgin, Underberg, Second Supplementary (Himeville).—Masson, Harrison & De Villiers, Pietermaritzburg.
- 5763/83—**Hall**, Cova Margaret, 9611100012009, Pear Tree Cottage, Underberg, First (Himeville).—Tomlinson Francis, Pietermaritzburg.
- 844/84—**Malan**, Johan, 2803055003003, Bluffweg 1146, Fynlands (Durban).—Volkskastrust, Pietermaritzburg.
- 906/84—**Moolman**, Petrus Lafras, 1504075003004, Victoriaweg 87, Newcastle (Newcastle).—Volkskastrust, Pietermaritzburg.
- 2497/83—**Alexander**, Margaret Angus, 9804200012009, Sunnyside Park Home, Sweetwaters Road, Pietermaritzburg.—Graham Harrison, Pietermaritzburg.
- 1740/83—**Pritchard**, Heila Francis, 2301310010004, 15 Dipdale Road, Malvern; Christopher Pritchard, 1902275025001 (Durban).—Merret & Berkowitz, Durban.
- 5055/81—**Kanbodlamah**, 800323682A, 34 Finch Street, Kharwastan, Chatsworth; Vasuthevan Cuppuasawmi, 2603255074055 (Chatsworth).—Himal D. Tugh & Co., Chatsworth.
- 984/84—**Duki**, 800463765, 801 Inanda Road, Newlands, Durban (Durban).—Raj Bodasing, M. A. Singh & Co., Durban.
- 557/84—**Soobramoney**, 800304963, 2 32nd Avenue, Umhlatuzana Township, Durban; Mooniamah, 800395893 (Chatsworth).—Raj Bodasing, M. A. Singh & Company, Durban.
- 131/82—**Rudhanie**, 800416198, 44 Archary Road, Clairwood, Durban, Amended First and Final Liquidation and Distribution (Durban).—Raj Bodasing, M. A. Singh & Company, Durban.

- 3609/83/3A—**Butcher**, Ronald Ross, 0406245006001, 1 Pioneer Road, Kloof, First (Pinetown).—Arthur Young & Company, Durban.
 3795/83—**Ramnath**, Ramesh, 5711105003054, 2 Yolani Place, Havenside, Chatsworth, Durban (Chatsworth).—Krish Govender & Company, Durban.
 5775/83—**Weldschidt**, Catherine, 3608120050015, 317 Randles Road, Sydenham, Durban; Henry Phillip Weldschidt, 3109135050019 (Durban).—Monica Agulhas, Durban.
 1045/84—**Van Jaarsveld**, Adriaan, 1601065045001, 51 Finsbury Court, 91 West Street, Durban; Johanna Jacomina van Jaarsveld, 0611010020000 (Durban).—L. J. Paola, Wright & Wilkinson, Durban.
 257/84—**Potter**, Chrissie Rennie Maxwell, 2010220100125, 23 District Drive, Merrivale Heights, Merrivale (Howick).—Standardtrust, Durban.
 449/84—**Gordon**, Lilian Elizabeth May, 2708180042000, 54 Carlton Towers, Somtseu Road, Durban (Durban).—Standardtrust, Durban.
 5895/83—**Munro**, Beryl Rosamund, 1305080007000, Trade Winds, 520 Seventh Street, Port Edward (Port Shepstone).—Standardtrust, Durban.
 4864/83—**Bagiam**, 800259034A, 109 Collier Avenue, Umhlatuzana Township (Chatsworth).—Clarkson, Cowley & Cowley, Durban.
 3768/83/4D—**Naidu**, Aungaamthoo, 3308055045052; Devanamma Naidu, 3604170054056 (Durban).—R. B. Lalla & Company, Durban.
 6311/83—**Taylor**, John Milburn, 0706125025009, C2 Kingfisher Crest, Knelsby Avenue, Hillcrest (Pinetown).—Standardtrust, Durban.
 1895/84—**Glenn**, Martha Maria, 0904260008001, 1502 Coastlands, 47 West Street, Durban; Clifford Pascoe Glenn, 1108185035003 (Durban).—Standardtrust, Durban.
 1511/84—**Roberts**, Raymond George Kendle, 1507305032008, Illovo Beach (Durban).—Standardtrust, Durban.
 985/84—**Earle**, Maisie Daphne, 0306200024009, 2 Lawson Mansions, 136 McDonald Road, Glenwood, Durban (Durban).—Standardtrust, Durban.
 5515/83—**Coffey**, Andrew Clark, 0805255015002, 6 Claygate, Pinetown (Pinetown).—S. Coffey, Kloof.
 2181/83—**Livingston**, Dorcas Eunice, 246007145W, Natal Settlers Memorial Home, Hutchinson Road, Durban (Durban).—Peat, Marwick, Mitchell & Co., Durban.
 5769/83/3C—**Surjuprosad**, Bechan, 2408265071053, 7 D'Aintree Avenue, Asherville, Durban; Santhee Surjuprosad, 2912160071050 (Durban).—R. S. Nowbath & Company, Durban.
 5346/83—**Larsen**, Agnes Katrine, 211457345W, 45 Broadway, Westville (Durban).—M. Richmond & Company, Durban.
 5481/81—**Narain**, Badree, 800358844A, widower, 15 Forest Lane, Overport, Durban, Amended First and Final (Durban).—Monty Moodley & Co., Durban.
 3983/83—**De Lange**, Michael Joseph, 211424299W, 91 Ronald Road, Montclair (Durban).—Shepstone & Wylie, Durban.
 5883/83—**Dhanam**, 800299624A, widow, 29 Sanpalpur Road, Merebank, Durban (Durban).—McKenzie Rowe & Hitchcock, Durban.

ORANJE-VRYSTAAT • ORANGE FREE STATE

By die kantoor van die Meester, BLOEMFONTEIN, en ook van die landdros van die distrik wanneer dit tussen hakies gemeld word.
 At the office of the Master, BLOEMFONTEIN, and also of the magistrate of the district when stated in parentheses.

- 2547/83—**Swanepoel**, Ivan Errol Frederick, 3404165046005, 11 Leisegang Street, Brandwag, Bloemfontein, Second Supplementary.—Barclays National Bank, Bloemfontein.
 637/84—**Jordaan**, Marthinus Johannes, 1012085001008, Du Plooyensingel 3, Fichardtspark, Bloemfontein.—Barclays-Nasionale Bank, Bloemfontein.
 495/84—**Cronje**, Pieter Johannes, 1506305023009, Koppie Alleenweg 186, Welkom; Emerentia Jacomina Christina Cronje, gebore Taljaard, 3902060050006 (Welkom).—Barclays-Nasionale Bank, Bloemfontein.
 705/84—**Schefermann**, William Adolph Reginald, 1511065016003, 3 Loop Street, Ladybrand; Catharina Cornelia Hoffman Schefermann, 2308180019007 (Ladybrand).—Barclays National Bank, Bloemfontein.
 7/84—**Vorster**, Willem Karel, 3907025002000, Emmetstraat 1, Villiers; Johanna Elizabeth Vorster, gebore Delport, 4101080002001 (Villiers).—Barclays-Nasionale Bank, Bloemfontein.
 667/84—**Fourie**, Wilhelmina Christina Neethling, 030731004006, President Boshoffstraat 4, Bloemfontein.—Barclays-Nasionale Bank, Bloemfontein.
 261/83—**Hanekom**, Martha Katrina, 4803170033008, President Steynstraat, Rouxville (Rouxville).—Barclays-Nasionale Bank, Bloemfontein.
 2156/83—**Loubser**, Louis Francois Benjamin, 3105125028005, Langverwacht, Senekal.—George Frederik Wessels, Bloemfontein.
 750/82—**Buys**, Petrus Jacobus, 3411255019008, Kerkstraat 5, Smithfield; Elizabeth Maud Buys, gebore Clack, 4203120068008, 14 dae (Smithfield).—Volkskastrust, Bloemfontein.
 2296/83—**Appelgrein**, Comelia Petronella Susanna, gebore Riekert, 1404240038003, Sassar Afree-oord, Bloemfontein.—Volkskastrust, Bloemfontein.
 1597/83—**Engelbrecht**, Gerhardus, 2604125010006, Schiedam, Villiers; Felicitas Engelbrecht, gebore Luyt, 3007280010002 (Villiers).—Zietsmans, Villiers.
 480/84—**Viljoen**, Anna Susanna, 0102170012003, Najaarsrus-ouetehuis, Parys (Kroonstad).—Volkskastrust, Klerksdorp.
 2583/82—**Brown**, Alfred Arthur, 5511015053003, Smallholding 16, Kleinplase, Bloemfontein.—H. F. Steyn, Bloemfontein.
 2528/83—**Stern**, Feige Gittel, 90122000200, 32 Dersley Street, Bayswater, Bloemfontein.—H. F. Steyn, Bloemfontein.
 1/84—**Coetzee**, Willem Nicolaas, 1512205021002, Steytlerstraat 21, Parys; Andriesa Johanna Stephanie Coetzee, 2609110029002 (Parys).—Santamtrust, Potchefstroom.
 2509/83—**Britz**, Jan Johannes, 1910175035004, Lanquedocstraat 6, Bayswater, Bloemfontein; Magdalena Elizabeth Brits, gebore Jordaan, 2310110025005.—Siebert en Honey, Bloemfontein.
 704/84—**Pienaar**, Zacharias Matheus Johannes, 1912275031008, Stalsweg 7b, Bloemfontein; Christina Barendina Pienaar, gebore Van Deventer, 2003030015004.—Santamtrust, Bloemfontein.
 607/84—**Terblanché**, James Kilgour, 5212225143003, Daubeneystraat 15, Fichardtspark, Bloemfontein; Aletta Johanna Terblanché, gebore Vergottine, 5609160074004.—Santamtrust, Bloemfontein.
 501/84—**Van Zyl**, Jaco Werner, 6310075042009, Constantiastraat 8, Welkom (Welkom).—Santamtrust, Bloemfontein.
 2004/83—**Van der Merwe**, Jan Bastiaan, 1808295018001, Hein Mariewoonstelle 5, Odendaalsrus (Odendaalsrus).—Santamtrust, Bloemfontein.
 1067/83—**Pienaar**, Willem Nicolaas, 0111055005008, Uitenhaag, Allenridge; Ellie Jacoba Pienaar, 406285836W (Odendaalsrus).—Standardtrust, Bloemfontein.
 71/84—**Van Pletzen**, Magdalena Susanna, 1407130039007, Sederhof-ouetehuis, Bethlehem; Jacobus Francois van Pletzen, 0708185018007 (Bethlehem).—Standardtrust, Bloemfontein.
 848/83—**Boulogne**, Bernhard, 3807155011005, Stormlaan, Plot 17, Panty de Faide, Bainsvlei, Supplémentère.—Standardtrust, Bloemfontein.
 255/84—**Steenkamp**, Gert Johannes, 12011015009006, Corneliusstraat 7, Villiers (Villiers).—Standardtrust, Bloemfontein.
 25/84—**Etsebeth**, Josia Johannes Jacobus, 1104285018007, Louwstraat 43, Wepener; Petronella Jacoba Etsebeth, 1209040066009 (Wepener).—Standardtrust, Bloemfontein.
 336/84—**Botes**, Anna Christina, 3309020039006, Suikerbekkiestraat 12, Fauna, Bloemfontein; Willem Cornelius Botes, 2605035017007.—Santamtrust, Bloemfontein.
 129/84—**Buter**, Gezinus, 1405125058008, Mikrolaan 29, Jan Cillierspark, Welkom; Trijntje Buter, 1202070038006 (Welkom).—Santamtrust, Bloemfontein.
 410/84—**Strydom**, Johannes Petrus, 3009135039004, Du Plessisstraat 12, Kestell; Johanna Aletta Strydom, 3011010015000 (Kestell).—Santamtrust, Bloemfontein.
 13/84—**Marais**, Pieter Johannes, 4206125037001, Lanquedocstraat, Bayswater, Bloemfontein; Tersia Marais, gebore Van der Walt, 4408030030002.—Santamtrust, Bloemfontein.
 690/84—**Labuschagne**, Albertus Johannes Jacobus, 2212225044006, Charcottstraat 70, Hospitaalpark, Bloemfontein; Margaretha Wilhelmina Jacoba Labuschagne, voorheen Bezuidenhout, gebore Lombaard, 2707190035004.—Santamtrust, Bloemfontein.

- 833/84—**Van der Westhuizen**, Anna Magdalena Jacoba, 2608270022005, Davisstraat 16, Kroonstad; Adriaan Johannes van der Westhuizen, 2004125035006 (Kroonstad).—Santamtrust, Bloemfontein.
- 714/82—**Köhler**, Gerhardus Wilhelmus Jacobsz, 1512225016008, Soetveld, Frankfort (Frankfort).—Van der Merwe Claassen en Louw, Frankfort.
- 714/82—**Köhler**, Gerhardus Wilhelmus Jacobsz, 1512225016008, Soetveld, Frankfort (Frankfort).—Van der Merwe Claassen en Louw, Frankfort.
- 2554/83C—**Potgieter**, Elizabeth Wilhelmina, 2008130004006, Barry de Kokrylaan 43, Panorama, Bethlehem; Johannes Philippus Potgieter, 1206065003008 (Bethlehem).—Ludwig Diener, Bethlehem.
- 46/84—**Pretorius**, Anna Truter, gebore Pienaar, 0310170016003, Siesta-ouetehuis, Generaal Conroystraat, Bloemfontein (Bloemfontein).—Volkskas-trust, Bloemfontein.
- 219/84—**Madiehe**, Nthibe Lawrence, 1868302, 876 Swartwoongebied, Bethlehem (Bethlehem).—Meyerowitz & Moore Ingelyf, Bethlehem.
- 1644/83/B—**Lubbe**, Maria Magdalena, voorheen Meintjes, gebore van Wyk, 448398592W, Tobie Mullerstraat 37, Philippolis (Philippolis).—H. A. Meintjes, Durban.
- 829/83—**Van den Heever**, Susanna Maria, 1003310003002, Woonstel 3, Fairview Mansions, Kroonstad (Kroonstad).—Du Randt & Louw, Kroonstad.
- 348/84—**Wessels**, Christina Johanna, 0102090002001, Lydia-tehuis, Ladybrand (Ladybrand).—J. J. Kleynhans & Kie, Ladybrand.
- 383/84—**Cronje**, Nicolas, 1306055004006, Tobie Mullerstraat 39, Philippolis (Philippolis).—I. A. J. Malherbe, Philippolis.
- 2390/83—**Steenkamp**, Johannes Nicolaas Cornelius, 1002165001004, Rianastraat 1, Naudeville, Welkom; Susanna Lucia Steenkamp, 2002260059008 (Welkom).—Wessels & Smith, Welkom.
- 1645/83—**Marais**, Maria Louisa, gebore Sutherland, 6403200071009, President Losjes Huis, Bloemfontein; Pieter Adriaan Marais, 5904025083005.—J. P. Daffue, Bloemfontein.
- 994/83/B—**Botha**, David Hercules, 0901265010008, Van der Lingenstraat 77, Kroonstad (Kroonstad).—J. H. Kleynhans & Vennote, Kroonstad.
- 151/84—**Barnard**, Anna Louisa, 9410160005007, Sederhof-ouetehuis, Bethlehem (Bethlehem).—Syfrets Trust, Kimberley.
- 1705/83—**Steyn**, Petrus Jacobus, 111884315, Nathanstraat 8, Bloemfontein; Frederika Jacoba Steyn, gebore Alberts, 014478464.—J. P. Daffue, Bloemfontein.
- 94/83—**Labuschagne**, Helena Catherina Petronella, gebore Mynhardt, 476471486W, Huis Vergesig, Zastron, Aanvullende en Finale (Zastron).—Malherbe Saayman & Vermaak, Zastron.
- 519/84—**Etsebeth**, Johannes Izak, 1312205003005, Grensstraat 20, Parys; Huijbrecht Johanna Eisebeth, 1707120029003.—Volkskas-trust, Klerksdorp.
- 576/84—**Dannhauzer**, Philippa Abrama, 0409130028007, Najaarsrus, Kamer 6, Parys (Parys).—Volkskas-trust, Klerksdorp.
- 1078/83—**Mackenzie**, Donald Ellis, 0811065028003, 206 Mitreton, Kellner Street, Bloemfontein.
- 658/84—**Weideman**, Pieter Andries Christiaan, 0912095017006, Sesde Straat 74, Heilbron; Esther Magdalena Weideman, 2306200021004 (Heilbron).—Volkskas-trust, Klerksdorp.
- 2516/83—**Cantley**, Hilda Daisy, 0011210016009, Siesta Home, 5 General Conroy Street, Dan Pienaar, Bloemfontein.
- 1815/83—**Coetzee**, Johannes Petrus, 3004245021000, Brianstraat 17, Odendaalsrus (Odendaalsrus).—Volkskas-trust, Bloemfontein.
- 547/84—**Smit**, Irene Effie, born Vels, 0308110008007, 21 Botha Street, Ladybrand.—C. J. Vels Smit, c/o Barclays National Bank, Kimberley.
- 2017/83—**Grundlingh**, John James, gebore Williamson, voorheen Wasserman, 0101260003005, Wesselstraat, Verkeerdevelei, distrik Brandfort (Brandfort).—Hendrikz & De Vletter, Brandfort.
- 2691/83—**Venter**, Richard Hurtle, 0112035006009, Boshoffstraat 39, Bethlehem (Bethlehem).—Peach & Du Preez, Bethlehem.
- 792/83—**Erasmus**, Doors Willem, 1101305001005, Odendaal, distrik Steynsrus (Steynsrus).—Lange & Venter, Steynsrus.
- 792/83—**Erasmus**, Doors Willem, 1101305001005, Odendaal, distrik Steynsrus (Steynsrus).—Lange & Venter, Steynsrus.
- 2124/83—**Louw**, Christiaan Rudolph Liebenberg, 0407215008001, Louville, Hertzogville, distrik Boshof, Eerste Likwidasië en Distribusie (Hertzogville).—Naudes, Bloemfontein.

INSOLVENSIEWET- EN MAATSKAPPYWETTE-KENNISGEWINGS INSOLVENCY ACT AND COMPANIES ACTS NOTICES

Vorm/Form J 28

BOEDEL OF MAATSKAPPYE WAT VOORLOPIG GESEKWESTREER OF GELIKWIDEER IS

Ingevolge artikel 17 (4) van die Insolvensiewet, 1936, en artikel 356 (1) van die Maatskappywet, 1973, word hierby deur die Meesters van die Hooggeregshof kennis gegee dat die boedels of maatskappye hieronder vermeld voorlopig op las van genoemde Hof gesekwestreer of gelikwideer is.

Die besonderhede word verstrek in die volgorde: Nommer van boedel/maatskappy; naam en beskrywing van boedel/maatskappy; datum waarop en afdeling van hof waardeur order gemaak is en op die aansoek van.

ESTATES OR COMPANIES SEQUESTERED OR WOUND UP PROVISIONALLY

Pursuant to section 17 (4) of the Insolvency Act, 1936, and section 356 (1) of the Companies Act, 1973, notice is hereby given by the Masters of the Supreme Court that the estates or companies mentioned below have been sequestered or wound up provisionally by order of the said Court.

The particulars are given in the following order: Number of estate/company; name and description of estate/company; date upon which and division of court by which order made and upon the application of.

- T1005/84—**Riverton Properties (Pty) Ltd**, registered office at First Floor, Bankovs Centre 80, Voortrekker Road, Potgietersrus. 17 May 1984, Transvaal Provincial. Anver Essack.
- T1024/84—**Cloete**, Christiaan Stephanus, Rooielsstraat 1179, Waverley, Pretoria. 22 Mei 1984, Transvaalse Provinsiale. Engineering Contracting & Equipment Hire Services (Edms) Bpk., t/a E.C.E. Finansiering.
- T1025/84—**Grobler**, Nicolaas Johannes, woonagtig te Railwaystraat 33, Oberholzer. 18 Mei 1984. Transvaalse Provinsiale. Hermanus Richard Lemmer.
- T1026/84—**Buitendach**, Petrus Johannes, salesman in the employ of J. L. de Bruin, t/a Shalom Motors, 446 Malherbe Street, Capital Park, Pretoria and Residing at 152 Edinburgh Street, Clubview, Pretoria. 15 May 1984. Transvaal Provincial. Matthys Johannes Petrus Bosch.
- T1034/84—**Neumeyer**, Gary Wynn, an adult male who resides at 3 Antonella Court, Wellington Road, Lombardy East, Johannesburg and is employed as a motor car salesman by Eastern B.M.W. (Pty) Limited of 712 Voortrekker Road, Brakpan. 22 May 1984. Witwatersrand Local. Evan Neumeyer.
- T1035/84—**Power Bakeries (Pty) Limited**, with its registered address at First Floor, Meininger Building, 43 Voortrekker Road, Warmbaths. 15 May 1984. Transvaal Provincial. Wanda Carroll.

- T1036/84—Kerr, Jacqueline Joan and Mark Philip Asmussen, trading in partnership under "The Style of Avenues Restaurant" at 47th Avenue Parktown North, Johannesburg. 22 May 1984. Witwatersrand Local. Hedlion (Pty) Ltd.
- T1040/84—Wolpe, Herbert, who is employed by Casa Bella (Pty) Limited, Pritchard Street, Johannesburg and who resides at 20 Ridge Road, Observatory, Johannesburg. 22 May 1984. Witwatersrand Local. Bhajohn Limited.
- T1046/84—Kerr, Jacqueline Joan, an adult female divorcee of 47th Avenue, Parktown North, Johannesburg and who resides at 4 Kingsway Mansions, Kingsway, Auckland Park, Johannesburg. 22 May 1984. Witwatersrand Local. Hedlion (Pty) Limited.
- T1056/84—Asmussen, Mark Philip, an adult male of 47th Avenue, Parktown North, Johannesburg and who resides at 4 Kingsway Mansions, Kingsway, Auckland Park, Johannesburg. 22 May 1984. Witwatersrand Local. Hedlion (Pty) Ltd.
- T938/84—Grobler, M. S., van die plaas Wales, Graskop, distrik Delmas, Pelgrims. 1 Mei 1984. Transvaalse Provinsiale. Supreme Motors, Mafikeng.
- T929/84—Kwik Supply Services (Pty) Limited, t/a Viking Car Services having its registered head office at Third Floor, Palace Building, corner of Pritchard and Rissik Streets, Johannesburg. 10/5/84. Witwatersrand Local. Terme Investments and Finance Company (Pty) Limited.
- T947/84—Roux, Thomas Jacobus, woonagtig te Grimbeeck Straat 92, Potchefstroom en werksaam te W and J Engineering Industriële gebied Potchefstroom. 3 Mei 1984. Transvaalse Provinsiale. Salmon Willem Roux.
- T948/84—Steyn, Johannes Jacobus, werksaam te Signs North, Stasiestraat 741, Pretoria-Noord woonagtig te Plot 8, Winter Nest, distrik Pretoria. 17/4/84. Transvaalse Provinsiale. Gideon Cornelis Zeelie.
- T939/84—Gregos Builders Supplies (Pty) Limited, geregistreerde adres geleë te Tweede Verdieping, Sivewrightlaan 124-134, Ellispark, Johannesburg. 17 April 1984. Transvaalse Provinsiale. Lona Construction (Edms.) Bpk.
- T928/84—De Jongh's Engineering and Motor Company (Withbank) (Edms.) Beperk, met geregistreerde kantoor te Hofmeyerstraat 3b, Witbank. 1/5/84. Transvaalse Provinsiale. Ex Parte.
- T999/84—Jakarta Trading (Pty) Limited, having its registered office at c/o Goldberg, Jaffe, Joselowsky and Partners, Sixth Floor, Saambou National Building, 130 Commissioner Street, Johannesburg. 15/5/84. Witwatersrand Local. Keith William Leggett.
- T998/84—Crown Cold Storage (Pty) Limited, having its registered office at care of Goldberg, Jaffe, Joselowsky and Partners, Sixth Floor, Saambou National Building, 130 Commissioner Street, Johannesburg. 15/5/84. Witwatersrand Local. Keith William Leggett.
- T949/84—Shepstone, George Evelyn, residing at 48 Kingswood Flats, Westlake Avenue, Weavind Park, Pretoria presently employed as a car salesman at McCarthy's, corner of Proes and Andries Streets, Pretoria. 24 April 1984. Transvaal Provincial. Ivor Forbes Keene.
- T977/84—A & S Fire Engineering (Pty) Ltd, having its registered office at the farm Waterval, Old Pretoria Road, Sandton. 15 May 1984. Witwatersrand Local.
- T968/84—De Villiers, Jacobus Wynand Louw, residing at 5 Erneststraat, Kenleaf, Brakpan. 15 May 1984. Witwatersrand Local. Jacobus Alwyn van Staden.
- T970/84—Patria Sport Vervaardigers (Eiendoms) Beperk, having its registered office at Third Floor, Mayeen House, 162 President Street, Johannesburg. 15 May 1984. Witwatersrand Local.
- T978/84—Kachrilas, Panayiotis, an adult male employed by Rank Xerox as a service manager and residing at 601 Killarney Wilds, Killarney, Johannesburg. 15 May 1984. Witwatersrand Local. Susan Mary Sneddon.
- T979/84—Zobo Stores (Pty) Limited, having its registered office at c/o Mohamed Moola, 48 Crown Road, Fordsburg, Johannesburg, and carrying on business as a general dealer at 22 Sutherland Avenue, Randfontein, Transvaal. 15/5/84. Witwatersrand Local. C & C Discount Corporation (Pty) Limited.
- T980/84—Strauss, Hendrik Frederik Johannes, woonagtig te die plaas Rietkuil, Leeudoringstad. 15/5/84. Transvaalse Provinsiale. Abraham Johannes Strauss.
- T969/84—Jassat, Rashid Mohamed, an adult male residing at 25a Sutherland Avenue, Randfontein and carries on business as Jasons. 15 May 1984. Witwatersrand Local. Yousuf Mohamed Adam.
- T982/84—Busmakers (Eiendoms) Beperk, met geregistreerde kantoor te Hoogstraat 74, Middelburg. 15 Mei 1984. Transvaalse Provinsiale. Ex parte.
- T711/84—Huisvesting Beleggings (Edms.) Beperk, geregistreerde kantoor te Patryslaan 32, Monumentpark, Pretoria. 13 Maart 1984. Transvaalse Provinsiale. Ex parte.
- T911/84—Flexhou (Edms.) Beperk, (onder voorlopige geregtelike bestuur). 8 Mei 1984. Transvaalse Provinsiale. Andre Johan Hessels. N.O.
- C326/84—Smit, Pieter Willem, administratiewe kantore is geleë te Yorkstraat 55, George. 15 Mei 1984. Kaap die Goeie Hoop Provinsiale. R. Shamley & Bekker Motors (Eiendoms) Beperk, h/a George Toyota.
- C327/84—Goodlad, Peter Kenneth, Oaklands, Blanco, George. 15 Mei 1984. Kaap die Goeie Hoop Provinsiale. R. Shamley & Bekker Motors (Eiendoms) Beperk, handeldrywend as George Toyota.
- C325/84—Goodlad, P. K. & P. W. Smit, administratiewe kantore geleë te Yorkstraat 55, George. 15 Mei 1984. Kaap die Goeie Hoop Provinsiale. R. Shamley & Bekker Motors (Eiendoms) Beperk, h/a George Toyota.
- C298/84—Rainbow Garden Irrigation (Pty) Ltd, 27 Wellington Avenue, Wynberg. 15 May 1984. Cape of Good Hope Provincial. Stewarts & Lloyds Trading (Pty) Ltd.
- C227/84—Zeelie, Frederick Stephanus, p/a J. S. P. Zeelie, Buffelsdrift, Pk. Outeniqua. 15 Mei 1984. Kaap die Goeie Hoop Provinsiale. Helena Elizabeth Boshoff.
- C307/84—Knoetze, Johannes Mynhardt, p/a Mobil Oil (Edms.) Bpk., Kaapstad. 11 May 1984. Kaap die Goeie Hoop Provinsiale. Johan van Wyk.
- C331/84—Breez & Bulb Importers (Proprietary) Limited, c/o Greenwood Ironside, 22nd Floor, Trust Bank Centre, Heerengracht, Cape Town. 11 May 1984. Cape of Good Hope Provincial. Simon Kramer.
- C322/84—Kenilworth Finance and Leasing (Proprietary) Limited, registered offices, c/o Rosenzweig and Wener, Strand Towers, Strand Street, Cape Town. 10 May 1984. Cape of Good Hope Provincial. Kenilworth Finance and Leasing (Proprietary) Limited.
- C129/84—Vraagom, Patrick Jeffrey, carrying business as a Bus and Taxi Service, Don Street, Diazville, Saldana. 6 March 1984. Cape of Good Hope Provincial. A. E. Frost (Proprietary) Limited.
- N235/84—Archary, Dhanasagren, 1 Lotus Road, Durban, Isipingo Rail, Durban. 7/5/84. Durban and Coast Local. Sudha Enterprises.
- K34/84—Louw, C. F., woonagtig te Kraankuilstasie, Kraankuil. 11 Mei 1984. Noord-Kaapse. Willem Christiaan van der Nest.
- K35/84—Maddocks, Arthur, 'n blanke man van Venusweg 14, Vryburg en wat handel dryf as Arthur's Video & Film Hire, te Markstraat, Vryburg. 11 Mei 1984. Noord-Kaapse Provinsiale. Clifford Quinton Peacock.
- K36/84—Smit, Koos, woonagtig te Selouslaan 3, Rhodesdene, Kimberley. 11 Mei 1984. Noord-Kaapse Provinsiale. Jacobus Lodewikus Terblanche.
- E126/84—Maclear Chicken Farm (Proprietary) Limited, with registered office at c/o K. N. Paterson & Co., 78 Cathcart Road, Queenstown. 10 May 1984. Eastern Cape. Francis Peter Hendricks.
- E128/84—East Cape Trailer Manufacturers (Pty) Ltd, 'n maatskappy met geregistreerde kantore te p/a Frans Vermaak & Kie, Ou Mutualgebou, Dalystraat, Uitenhage. 8 Mei 1984. Suidoos-Kaapse Plaaslike. Leon van Wyk.
- E129/84—Boyd, Peter Claude Godfray, an adult male residing at 27 Thames Road, Fernglen, Port Elizabeth. 8 May 1984. South Eastern Cape Local. Uptons Furnishers (Pty) Ltd.
- N234/84—Musgrave Plumbers (Pty) Limited, Suite 19, Musgrave Centre, Musgrave Road, Durban. 10/5/84. Durban and Coast Local. Musgrave Plumbers (Pty) Limited.
- B125/84—Wesselsbron Motors (Edms.) Bpk., 'n maatskappy met beperkte aanspreeklikheid, behoortlik geregistreer ingevolge die Maatskappywette van die R.S.A., met sy geregistreerde kantoor te Eerste Verdieping, Elizabethhuis, Elizabethstraat 10-12, Welkom, en met sy hoofbesigheidsplek binne die jurisdiksie van hierdie Agbare hof, te Voortrekkerstraat 20, Wesselsbron, waar dit sake doen onder die naam Wesselsbron Toyota as 'n motorhandelaar en motorwerkswinkel. 10 Mei 1984. Oranje Vrystaatse Provinsiale. Willem Johannes Stephanus Vosloo.
- B126/84—Landman, Jurgens Johannes, woonagtig te Impalastraat 10, Odendaalsrus. 10 Mei 1984. Oranje Vrystaatse Provinsiale. Willem Petrus van der Westhuizen.

Vorm/Form J 29

EERSTE BYEENKOMSTE VAN SKULDEISERS, KONTRIBUANTE, LEDE OF SKULDBRIEFHOERS VAN GESEKWESTREERDE BOEDELS, MAATSKAPPYE IN LIKWIDASIE OF ONDER VOORLOPIGE GEREGETELIKE BESTUUR

Nademaal die boedels of maatskappye hieronder vermeld op las van die Hooggeregshof van Suid-Afrika gesekwestreer, gelikwieder of onder voorlopige geregetelike bestuur geplaas is, word hierby deur die Meesters van die Hooggeregshof ingevolge artikels 17 (4) en 40 (1) van die Insolvensiewet, 1936, artikels 119 (3), 125 (1) en 196*bis* (4) van die Maatskappywet, 1926, en artikels 356 (1), 364 (1) en 429 van die Maatskappywet, 1973, kennis gegee dat 'n eerste byeenkoms van skuldeisers, kontribuante, lede of skuldbriefhouers van genoemde boedels of maatskappye op die datums, ure en plekke hieronder vermeld vir die bewys van vorderings teen die boedels of maatskappye, die verkiesing van kurators, likwidateurs of geregetelike bestuurders, of vir die doeleindes bedoel in artikels 364 of 431 van Wet 61 van 1973, na gelang van die geval, gehou sal word.

Die besonderhede word verstrek in die volgorde: Nommer van boedel/maatskappy; naam en beskrywing van boedel/maatskappy; datum van die voorlopige en datum van die finale bevel, en afdeling van hof waardeur order gemaak is, en datum, uur en plek van byeenkoms.

In 'n plek waarin 'n kantoor van 'n Meester is, word die byeenkoms voor die Meester en op ander plekke voor die Landdros gehou.

FIRST MEETINGS OF CREDITORS, CONTRIBUTORIES, MEMBERS OR DEBENTURE-HOLDERS OF SEQUESTERED ESTATES, COMPANIES BEING WOUND UP OR PLACED UNDER PROVISIONAL JUDICIAL MANAGEMENT

The estates and companies mentioned below having been placed under sequestration, being wound up or having been placed under provisional judicial management by order of the Supreme Court of South Africa, Masters of the Supreme Court hereby give notice, pursuant to sections 17 (4) and 40 (1) of the Insolvency Act, 1936, sections 119 (3), 125 (1) and 196*bis* (4) of the Companies Act, 1926, and sections 356 (1), 364 (1) and 429 of the Companies Act, 1973, that a first meeting of creditors, contributories, members or debenture-holders of the said estates or companies will be held on the dates and at the times and places mentioned below, for proof of claims against the estates or companies, the election of trustees, liquidators or judicial managers or for the purposes referred to in sections 364 or 431 of Act 61 of 1973, as the case may be.

The particulars are given in the following order: Number of estate/company; name and description of estate/company; date of the provisional and date of the final order, and division of court by which order made, and date, hour and place of meeting.

Meetings in a place in which there is a Master's Office, will be held before the Master; elsewhere they will be held before the Magistrate.

- T1522/83—**Pot Pourri Nurseries (Pty) Ltd**, having its registered head office at First Floor, Volkskas Building, Kruger Street, Krugersdorp. 23 August 1983—13 December 1983, Witwatersrand Local. 22 June 1984, 09h30, Krugersdorp.
- T.275/84—**Hughes, Robert Henry**, an adult male, ordinarily employed at 6 Vogt Street, Crown Industrial, Johannesburg. 8 February 1984—15 May 1984, Witwatersrand Local. 20 June 1984, 09h00, Johannesburg.
- T665/84—**Fotofast George (Pty) Ltd**, having its registered office at Second Floor, Burlington House, 22 Rissik Street, Johannesburg. 27/3/84—15/5/84, Witwatersrand Local. 20 June 1984, 09h00, Johannesburg.
- T687/84—**Joooste, Peter John Robert**, 'n meederjarige sakeman, woonagtig te Barbara van Wykstraat 10, Discovery, Roodepoort. 23/3/84—8/5/84, Witwatersrandse Plaaslike. 20/6/84, 09h00, Roodepoort.
- T689/84—**Zains (Pty) Ltd**, Registered offices at 193 11th Avenue, Laudium, Pretoria. 4/4/84—1/5/84, Transvaal Provincial. 22 June 1984, 10h00, Pretoria.
- T798/84—**Mathewson, Robert Charles Alfred**, residing at 24 Rae Frankel Street, Brackenhurst, Alberton. 17/4/84—8/5/84, Witwatersrand Local. 20/6/84, 09h00, Alberton.
- T698/84—**Claassens, Dirk Johannes**, 'n boer van die plaas Doornhoek, distrik Wakkerstroom. 3/4/84—1/5/84, Transvaalse Provinsiale. 26/6/84, 10h00, Wakkerstroom.
- T467/84—**Smit, Derek**, presently residing at 319, Kings Ransom, Wolmarans Street, Joubert Park, Johannesburg. 2 March 1984—9 May 1984, Witwatersrand Local. 20 June 1984, 09h00, Johannesburg.
- T709/84—**Enslin, Hendrik Lourens Marthinus**, Strydomstraat 6, Potgietersrus, Transvaal. 13/3/84—1/5/84, Transvaalse Provinsiale. 21 Junie 1984, 10h00, Potgietersrus.
- T700/84—**Munro, Mark**, Ebenezer View Chalets, Ebenezer Dam, District Pietersburg. Transvaal. 27 March 1984—17 April 1984, Transvaal Provincial. 22 June 1984, 09h00, Pietersburg.
- T770/84—**Swart, John Benjamin**, 'n Arbeidsvoorman werksaam te p/a Mnr. Frans van Aswegen, Franet Saagmeule, Jacobsstraat, Carolina. 3/4/84—1/5/84, Transvaalse Provinsiale. 26/6/84, 14h00, Carolina.
- T769/84—**Rhodes, Patrick**, 612 Reitz Street, Sunnyside, Pretoria, Transvaal. 3/4/84—1/5/84, Transvaalse Provinsiale. 22/6/84, 10h00, Pretoria.
- T809/84—**Reeve, John** an adult male who conducts a second hand motor car sales business from his home at 5a Badenhorst Town House, Ajax Road, Brakpan. 17/4/84—8/5/84, Witwatersrand Local. 22/6/84, 10h00, Brakpan.
- T569/84—**Greyling, Francois Frederik**, woonagtig te Jutastraat 20, Vanderbijlpark en is 'n operateur by Yskor, Vanderbijlpark. 20/3/84—17/4/84, Transvaalse Provinsiale. 22 Junie 1984, 10h00, Vanderbijlpark.
- T236/84—**Elsburg Bearings and Hydraulics (Pty) Ltd**, having its registered office at c/o Voortrekker and Marais Streets, Elsburg, Germiston, Transvaal. 7/2/84—15/5/84, Witwatersrand Local. 22 June 1984, 09h30, Germiston.

- T537/84—**Crosskill**, William Bruce, 243 Clark Street, Brooklyn, Pretoria. 13/3/84—3/4/84, Transvaal Provincial. 22/6/84, 10h00, Pretoria.
- T737/84—**Inat (Pty) Ltd**, t/a Arrow Estates, having its registered office at c/o Bryan Ferreira and Company, 203 Southern Medical Centre, La Rochelle, Johannesburg. 10/4/84—15/5/84, Witwatersrand Local. 20/6/84, 09h00, Johannesburg.
- T647/84—**Klaassen**, Wynand Johannes, 'n motorwerktuigkundige werksaam te Weedons Minerals (Edms.) Bpk., Thabazimbi, 27/3/84—17/4/84, Transvaalse Provinsiale. 22 Junie 1984, 10h00, Thabazimbi.
- T638/84—**Joubert**, Kepler, werksaam te Surpa Toyota, Jan van Riebeeckstraat 204a, Middelburg, Transvaal, en woonagtig te Frewinstraat 1, Clubville, Middelburg, Transvaal. 27/3/84—17/4/84, Transvaalse Provinsiale. 20/6/84, 10h00, Middelburg, Transvaal.
- T419/84—**Hattingh**, Dewald Lambertus, woonagtig te die plaas Vissershoeck, De Wildt, Transvaal. 29/2/84—17/4/84, Transvaalse Provinsiale. 22 Junie 1984, 10h00, Pretoria.
- T779/84—**Crib Freight (Pty) Ltd**, having its registered office at suite 102 Legal and General Chambers, corner of Louis Botha Avenue, and Sixth Street, Orange Grove, Johannesburg, a varying on business as such at 104 Mackay Avenue, Blairgowrie, Randburg. 10/4/84—8/5/84, Witwatersrand Local. 20/6/84, 09h00, Randburg.
- T577/84—**Bezuidenhout**, Jan Johannes, 'n boer van die plaas Elim distrik Barberton, Transvaal. 20/3/84—17/4/84, Transvaalse Provinsiale. 22/6/84, 09h30, Barberton.
- T742/84—**Du Plessis**, Andries Johannes, who resides at 118 Langeeman Street, Randgate, Randfontein. 10 April 1984—8 May 1984, Witwatersrand Local. 21 Junie 1984, 09h00, Randfontein.
- T351/84—**Du Plooy**, Johannes Stephanus, woonagtig te Hubbardstraat 9, Ermelo. Finale bevel: 15/5/84, Transvaalse Provinsiale. 22/6/84, 09h30, Ermelo.
- T793/84—**Hoses and Hoses (Pty) Ltd**, having its registered office at 534 Cliff Lane, Waterkloof Ridge, Extension 2, Pretoria, and its principal place of business is situated at corner of Voortrekker Road and Maré Streets, Elsburg, Germiston. 17 April 1984—15 May 1984, Witwatersrand Local. 25 Junie 1984, 10h00, Pretoria.
- T753/84—**Eikeblare (Pty) Ltd**, having its registered head office at c/o G. Gambanis and Company, Seventh Floor, Plein Street, Johannesburg. 22/3/84—15/5/84, Witwatersrand Local. 20/6/84, 09h00, Johannesburg.
- C257/84—**Wittert Ceramic Industries**, p/a Arthur Anderson and Company, 12th Floor, Shell House, Riebeeck Street, Cape Town. 13 April 1984—15 May 1984, Cape of Good Hope Provincial. 22 Junie 1984, 9 a.m., Cape Town.
- C258/84—**Hamid**, Abdushakoor, t/a Family Butchery, 91 Roodebloem Road, Woodstock. 18/4/84—16/5/84, Cape of Good Hope Provincial. 22/6/84, 09h00, Cape Town.
- C236/84—**Grundling**, Cornelius Jacobus Johannes, a farmer of 16 Skaap Road, Philippi previously trading as a farmer at plot 3n6 Mogogong, Hartswater District, near Warrenton, Cape. 18/4/84—9/5/84, Cape of Good Hope Provincial. 21/6/84, 09h00, Wynberg.
- C226/84—**Bougard**, Fanie, residing at 4 Hill Street, Sarepta Kuils River. 11/4/84—9/5/84, Cape of Good Hope Provincial. 20 Junie 1984, 09h00 am., Kuils River.
- C279/84—**Heller Art and Handicraft Industries (Pty) Ltd**, trading as Ch-ien Pottery and crafts and Ashi Pottery Shop, Lakeside. 24 April 1984—15 May 1984, Cape of Good Hope Provincial. 21 Junie 1984, 9 am, Wynberg.
- C247/84—**Coetzee**, Gideon, p/a Madeliefstraat 19, Blomtuin, Bellville, Kaap. 11 April 1984—15 Mei 1984, Kaap die Goeie Hoop Provinsiale. 26/6/84, 11 vm., Bellville.
- C.230/84—**Schubert**, Hans Gunther Alfred, p/a Cloetes Brei en Naaldwerksentrum, Shoprite Winkelsentrum, Porterstraat 54a, Worcester. 4 April 1984—25 April 1984, Kaap die Goeie Hoop Provinsiale. 20/6/84, 10h00, Worcester.
- C191/84—**Coetzee**, Theunis Johannes (Junior) in diens van Handelshuis (Moorreesburg) Koöperatief Beperk te Moorreesburg, Kaapstad, Persoonsnommer: 5410225085006, Datum van geboorte: 22/10/54. 11/4/84—9/5/84, Kaap die Goeie Hoop Provinsiale. 15/6/84, 10 am., Moorreesburg.
- C242/84—**Plaza Engineering (Pty) Ltd**, registered office at Plaza Centre, corner of Beaconway and Linus Street, Beaconvale, Parow. 11 April 1984—9 May 1984, Cape of Good Hope Provincial. 12/6/84, 11h00, Bellville.
- C129/84—**Vraagom**, Patrick Jeffrey, carrying on business as a Bus and Taxi Service, at Don Street, Diazville, Saldanha, Cape. 6/3/84—15/5/84, Cape of Good Hope Provincial. 13/6/84, 10h00, Vredenburg.
- C232/84—**Naude**, Christiaan Arnoldus Jacobus, woonagtig te Cederprovolaan 13, Worcester. Identiteitsnommer.: 5109295067007, Geboortedatum: 29 September 1951. Finale bevel: 27/4/84, Kaap die Goeie Hoop Provinsiale. 20/6/84, 10h00, Worcester.
- C272/84—**Interiors Incorporated (Pty) Ltd**, registered offices at 501 Matador Centre, Strand Street, Cape Town. 19/4/83—10/5/84, Cape of Good Hope Provincial. 15/6/84, 09h00, Cape Town.
- C241/84—**Heins**, Francois Arnold Hermann, residing on a farm Verrekyker, District of Wolseley, Identity number: 5603055020008, Date of birth: 9 May 1956. 5/4/84—9/5/84, Cape of Good Hope Provincial. 20/6/84, 10.00 am., Wolseley.
- C243/84—**Cardo Holdings (Pty) Ltd**, Registered office at Plaza Centre corner of Beaconway and Linus Street, Beaconvale, Parow, Cape. 11 April 1984—9 May 1984, Cape of Good Hope Provincial. 19 Junie 1984, 11 am., Bellville.
- C190/84—**Gaybba**, Johannes Jacobus Hermanus, woonagtig te Joubertstraat 22, Ceres. Identiteitsnommer: 5505190104003, Geboortedatum: 19 Mei 1955. 19/4/84—15/5/84, Kaap die Goeie Hoop Provinsiale. 15 Junie 1984, 10h00, Ceres.
- C154/84—**De Villiers**, Jan Abraham Bernardus, woonagtig te Akhasialaan 10, Velddrift. Identiteitsnommer: 3007125056004, Geboortedatum: 12 Julie 1930. 16/3/84—18/4/84, Kaap die Goeie Hoop Provinsiale. 13/6/84, 10h00, Vredenburg.
- N191/84—**Trinity Construction (Pty) Ltd**, 4/4/84—4/5/84, Durban and Coast Local. 20/6/84, 09h00, Durban.
- N170/84—**Nepaul**, Frank, 23/3/84—4/5/84, Durban and Coast Local. 19/6/84, 09h00, Harding.
- N234/84—**Musgrave Plumbers (Pty) Ltd**, Final order: 10/5/84, Durban and Coast Local. 20/6/84, 09h00, Durban.
- N108/84—**Moosa**, Abdool Sathar, trading as Milton Demolishers. 1 July 1983—22 July 1983, Durban and Coast Local. 20/6/84, 09h00, Durban.
- B110/84—**Jacobs**, Frans Johannes, Hermanus, woonagtig te die plaas Gannahoeck, distrik Jacobsdal, OVS. 19/4/84—10/5/84, Oranje-Vrystaatse Provinsiale, 20/6/84, 10h00, Jacobsdal.
- B113/84—**Yelverton**, Ralph Henri, woonagtig te Stateway 347, Welkom. 19/4/84—10/5/84, Oranje-Vrystaatse Provinsiale, 20/6/84, 10h00, Welkom.
- B112/84—**Oosthuysen**, Jacobus Hendrikus, woonagtig te Rocco distrik, Harrismith, OVS. 19/4/84—10/5/84, Oranje-Vrystaatse Provinsiale, 20/6/84, 09h00, Harrismith.
- E95/84—**Stark**, Desmond, wie as 'n algemene handelaar sake doen te Mario's Kafee, Moselweg 49a, Uitenhage. 3 April 1984—1 Mei 1984, Suidoos-Kaapse Plaaslike. 20 Junie 1984, 10h00, Uitenhage.
- N18/84—**Eastberg Plant Hire (Pty) Ltd**, 12/1/84—4/5/84, Durban and Coast Local. 21/6/84, 10h00, Pinetown.
- B46/84—**Wagon Wheels Engineering (Edms.) Bpk.**, 'n maatskappy met beperkte aanspreeklikheid, behoorlik geregistreer volgens die Maatskappywet van R.S.A. en met hoofplek van besigheid te Industrieleweg 5, Ficksburg en met geregistreerde hoofkantoor te President Boshoffstraat 32, Bethlehem. Die Respondent Maatskappy het by eersgenoemde adres besigheid gedoen as vervaardigers en herstellers van algemene ingenieurswerk. 23 Februarie 1984—10 Mei 1984, Oranje-Vrystaatse Provinsiale, 22 Junie 1984, 09h30, Bethlehem.
- B104/84—**La Vogue Ladies Wearing Apparel (Pty) Ltd**, Respondenta a company with Ltd Liability duly incorporated according to the company laws of the R.S.A., having registered head offices at Shop 20, FVB Centre, Bloemfontein. 17 April 1984—10 May 1984, Orange Free State Provincial, 20 Junie 1984, 10h00, Bloemfontein.
- B108/84—**Combrinck**, Michael Johannes, woonagtig te Westphollstraat 35, Bloemfontein, 19/4/84—10/5/84, Oranje-Vrystaatse Provinsiale, 20/6/83, 10h00, Bloemfontein.
- B109/84—**Devenier**, Jan Stephanus, woonagtig te Shawestraat 4, Kroonstad. 19/4/84—10/5/84, Oranje-Vrystaatse Provinsiale, 20/6/84, 09h30, Kroonstad.

Vorm/Form 1

AANSTELLING VAN KURATORS EN LIKWIDATEURS EN BEWYS VAN VORDERINGS IN GESEKWESTREERDE BOEDEL OF MAATSKAPPYE IN LIKWIDASIE

Ingevolge artikels 40 (3), 56 (3) en 77 van die Insolvensiewet, 1936, artikels 129, 179 en 182 van die Maatskappywet, 1926, en artikels 339, 366, 375 (5) (b) en 402 van die Maatskappywet, 1973, word hierby kennis gegee dat die persone hieronder vermeld as kurators of likwidateurs aangestel is, na gelang van die geval, en dat persone wat enigiets aan die boedels of maatskappye verskuldig is die skulde, tensy anders vermeld, onmiddellik by genoemde kurators of likwidateurs moet betaal.

Byeenkomste van skuldeisers of kontribuante van genoemde boedels of maatskappye sal gehou word op die datums, ure en plekke hieronder vermeld vir die bewys van vorderings teen die boedels of maatskappye, vir die ontvangs van die verslae van die kurators of likwidateurs oor die sake en toestand van die boedels of maatskappye, en om opdragte aan die kurators of likwidateurs uit te reik betreffende die verkoop of opvordering van gedeeltes van die boedels of bates van die maatskappye of betreffende aangeleenthede rakende die beheer daarvan.

Die besonderhede word verstrek in die volgorde: Nommer van boedel/maatskappy; naam en beskrywing van boedel/maatskappy; naam en adres van kurator of likwidateur, en datum, uur en plek van byeenkoms en tydperk waarin skuld betaal moet word, indien dit nie onmiddellik moet geskied nie.

In 'n plek waarin 'n kantoor van 'n Meester is, word die byeenkoms voor die Meester en op ander plekke voor die Landdros gehou.

APPOINTMENT OF TRUSTEES AND LIQUIDATORS AND PROOF OF CLAIMS IN SEQUESTRATED ESTATES OR COMPANIES BEING WOUND UP

Pursuant to sections 40 (3), 56 (3) and 77 of the Insolvency Act, 1936, sections 129, 179 and 182 of the Companies Act, 1926, and sections 339, 366, 375 (5) (b) and 402 of the Companies Act, 1973, notice is hereby given that the persons mentioned below have been appointed trustees or liquidators, as the case may be, and that the persons indebted to the estates or companies are required to pay their debts to them forthwith unless otherwise indicated.

Meetings of creditors or contributories of the said estates or companies will be held on the dates and at the times and places mentioned below, for proof of claims against the estates or companies, for the purpose of receiving the trustees' or liquidators' reports as to the affairs and conditions of the estates or companies and for giving the trustees or liquidators directions concerning the sale or recovery of any parts of the estates or assets of the companies or concerning any matter relating to the administration thereof.

The particulars are given in the following order: Number of estate/company; name and description of estate/company; name and address of trustee or liquidator and date, hour and place of meeting and period within which debt must be paid, if this is not to be done forthwith.

Meetings in a place in which there is a Master's Office, will be held before the Master; elsewhere they will be held before the Magistrate.

- T242/84—**Romantos Investments (Pty) Ltd**, in liquidation; C. P. van Zyl, c/o Highveld Trust & Management Co. (Pty) Ltd, P.O. Box 10463, Johannesburg, 2000. 4/7/84, 9 a.m., Johannesburg.
- E112/84—**Corporation Building (Pty) Ltd**, in voluntary liquidation; Basil Fanarof, First Floor, Quinbrow Chambers, 15 Western Road, Port Elizabeth.
- K4/84—**Jordaan**, Johan Louis, 'n boer woonagtig te Hartbeesweg 26, Vryburg; Roelof Davel du Plessis, Posbus 760, Bloemfontein en Hendrik Gert van der Walt, Posbus 540, Bloemfontein. 25 Julie 1984, 09h00, Vryburg.
- E113/84—**Elfb House (Pty) Ltd**, in voluntary liquidation; Basil Fanarof, First Floor, Quinbrow Chambers, 15 Western Road, Port Elizabeth.
- K12/84—**Marais, A**, handeldrywende as Archies Music House & Musikland; B. B. Benade, p/a Engelsman & Benade, Posbus 609, Kimberley. 27 Junie 1984, 10.00 vm., Kimberley.
- T1566/83—**Afromat (Pty) Ltd**, in liquidation; J. G. R. Seagers (Liquidator), c/o Johannesburg Trust Co. (Pty) Ltd, P.O. Box 95177, Grant Park, 2051. 1984-06-20, 10h00, Benoni.
- B292/83—**Chris Can Do**, in likwidasie, handeldrywende as sulks te Welkom; George Frederik Wessels, p/a Symington & De Kok, Posbus 760, Bloemfontein, 9300. 20 Junie 1984, 10h00, Welkom.
- B50/84—**J & B Boerdery (Edms.) Bpk.**, handeldrywende as Model Slaghuys, Theunissen, in likwidasie; George Frederik Wessels, p/a Symington & De Kok, Posbus 760, Bloemfontein, 9300. 20 Junie 1984, Bloemfontein.
- B293/83—**Murphy**, John; F. B. Pretorius, p/a E. G. Cooper & Seuns, Cooper House, St Andrewstraat 157, Posbus 27, Bloemfontein, 9300. 20 Junie 1984, 10h00, Virginia.
- C172/84—**Sydney Residences (Pty) Ltd**, in members' voluntary liquidation. Brian Hugh Lombard, P.O. Box 4490, Cape Town.
- C674/83—**Malherbe**, Gideon, formerly trading as Malherbe Transport, 79 Mill Street, Strand, 4805045028006, 4/5/48; S. M. Gore, c/o Sanek Cape (Pty) Ltd, formerly Kaap Vaal Trust (Cape) (Pty) Ltd, Seventh Floor, Phoenix House, Burg Street, Cape Town. 27 Junie 1984, 10h00, Strand.
- C708/83—**Whitehead**, Strahmore Basil, residing at 11 Van Riebeeck Street, Montague, 2805095028007, 9/5/28; S. M. Gore, c/o Sanek Cape (Pty) Ltd, formerly Kaap Vaal Trust (Cape) (Pty) Ltd, Seventh Floor, Phoenix House, Burg Street, Cape Town. 28 Junie 1984, 10h00, Montague.
- C39/84—**Executive Business Products (Pty) Ltd**, in liquidation; S. M. Gore, c/o Sanek Cape (Pty) Ltd, formerly Kaap Vaal Trust (Cape) (Pty) Ltd, Seventh Floor, Phoenix House, Burg Street, Cape Town. 28 Junie 1984, 09h00, Wynberg.
- T1641/83—**Van Niekerk**, Adam Adriaan; J. R. Galloway, Posbus 2851, Johannesburg. 28 Junie 1984, 09h00, Randfontein.
- T73/84—**Randfontein Electrical Contractors (Pty) Ltd**, in likwidasie; B. G. S. de Wet, Posbus 2851, Johannesburg. 12 Julie 1984, 09h00, Randfontein.
- T416/84—**Teleflora S A (Pty) Ltd**, in likwidasie; B. G. S. de Wet, Posbus 2851, Johannesburg. 4 Julie 1984, 09h00, Johannesburg.
- T503/84—**J. Rankin (Pty) Ltd**, in likwidasie; B. G. S. de Wet, Posbus 2851, Johannesburg. 4 Julie 1984, 09h00, Johannesburg.
- T2072/83—**Hattingh**, R. H.; J. F. Carstens, Posbus 1990, Pretoria. 25/6/84, 10 vm., Pretoria.
- T2072/83—**Botha**, H. R.; J. F. Carstens, Posbus 1990, Pretoria. 27/6/84, 10 vm., Rustenburg.
- T1386/83—**Cargo Tanker Services (Pty) Ltd**, in likwidasie; J. F. Carstens, Posbus 1990, Pretoria. 27/6/84, 10 vm., Pretoria.
- T1817/83—**De Winter**, A. M.; J. F. Carstens, Posbus 1990, Pretoria. 29/6/84, 10 vm., Pretoria.

- T1990/83—V. d. Berg, L.; J. F. Carstens, Posbus 1990, Pretoria. 29/6/84, 10 vm.
 T1636/83—Roux, P. J.; J. F. Carstens, Posbus 1990, Pretoria. 28/6/84, 10 vm., Potgietersrus.
 T2007/83—Kaycee Furnitures Designs (Pty) Ltd, in liquidation; Manfred Holzman and Selwyn Trakman, c/o Transvaal Board of Trustees (Pty) Ltd, P.O. Box 7062, Johannesburg, 2000. 22 June 1984, 9.30 a.m., Krugersdorp.
 T1972/83—Kimber, Eunice Audrey; Mervyn I. Swartz, c/o Rand Board of Trustees, P.O. Box 308, Johannesburg, 2000. 27th June 1984, 9.00 a.m., Johannesburg.
 T535/84—Bailey, Gerald John; Mervyn I. Swartz, c/o Rand Board of Trustees, P.O. Box 308, Johannesburg, 2000. 27 June 1984, 9.00 a.m., Johannesburg.
 T1922/83—Middel Public Relation Consultants (Pty) Ltd, in liquidation. Mervyn I. Swartz, c/o Rand Board of Trustees, P.O. Box 308, Johannesburg, 2000. 27 June 1984, 9.00 a.m., Johannesburg.
 C63/84—Geluk Properties (Pty) Ltd, in voluntary liquidation; David John Rennie and Jeanette Kathleen, Läppchen, 85 St George's Street, Cape Town.
 C706/83—Oaks Court (Pty) Ltd, in voluntary liquidation; I. Jowell, P.O. Box 3147, Cape Town, 8000.
 T635/84—Spruit Boerdery (Pty) Ltd, in voluntary liquidation; Peter Joel Katzenellenbogen, P.O. Box 1370, Johannesburg.
 T1933/83—Pact Finance Company (Pty) Ltd; Norman Sifris, P.O. Box 4128, Johannesburg. 20/6/84, 09h00, Johannesburg.
 T735/84—Lekton Properties (Pty) Ltd, in voluntary liquidation; Martin B. Behr, c/o Arthur Andersen & Co., P.O. Box 3652, Johannesburg, 2000.
 T175/84—Levin, I.; Neil Bowman, P.O. Box 10527, Johannesburg. 20 June 1984, 09h00, Johannesburg.
 T1955/83—Quantum Chemicals (Pty) Ltd, in liquidation; Neil Bowman, P.O. Box 10527, Johannesburg. 20 June 1984, 09h00, Johannesburg.
 T2008/83—Louis Locke Estates (Pty) Ltd, in liquidation; Neil Bowman, P.O. Box 10527, Johannesburg. 20 June 1984, 09h00, Johannesburg.
 T78/84—Jobstream (Pty) Ltd, in liquidation; Neil Bowman, P.O. Box 10527, Johannesburg. 20 June 1984, 09h00, Johannesburg.
 T2156/83—Hamron (SA) (Pty) Ltd, in liquidation; Norman Klein, P.O. Box 10527, Johannesburg. 20 June 1984, 09h00, Johannesburg.
 T1915/83—Flinkerbell (Pty) Ltd, in liquidation; Leslie Cohen, P.O. Box 10527, Johannesburg. 20 June 1984, 09h00, Johannesburg.
 T75/84—Galaxy Printers (Pty) Ltd, in liquidation; Julius Hirshberg, P.O. Box 10527, Johannesburg. 20 June 1984, 09h00, Johannesburg.
 T174/84—Waytem (Pty) Ltd, in liquidation; Leslie Cohen, P.O. Box 10527, Johannesburg. 20 June 1984, 09h00, Johannesburg.
 T2236/83—Casba Movid (Pty) Ltd, in liquidation; Leslie Cohen, P.O. Box 10527, Johannesburg. 22 June 1984, 09h30, Germiston.
 T2216/83—Preira, C. R.; Leslie Cohen, P.O. Box 10527, Johannesburg. 22 June 1984, 09h30, Germiston.
 T1658/83—Cablecar Motor & Accessories (Pty) Ltd, in liquidation; Leslie Cohen, P.O. Box 10527, Johannesburg. 22 June 1984, 09h30, Germiston.
 T6/84—Vaal Communications (Pty) Ltd, in liquidation; Neil Bowman, P.O. Box 10527, Johannesburg. 22 June 1984, 10h00, Vereeniging.
 T1869/83—Daph Ray Structures (Pty) Ltd, in liquidation; Leslie Cohen, P.O. Box 10527, Johannesburg. 20 June 1984, 10h00, Benoni.
 C130/84—Klein River Estates Share Block (Pty) Ltd; Patrick Alan Barnett, Seventh Floor, Strand Tower, Strand Street, Cape Town, 8001.
 C814/83—Fontana (Pty) Ltd, in voluntary liquidation; Ivor Jowell, P.O. Box 3147, Cape Town, 8000.
 C778/83—Jackadele Investments (Pty) Ltd; I. Jowell, P.O. Box 3147, Cape Town, 8000.
 N386/82—Kodi, Benjamin Gerald, born on 13/2/31, Identity No. 3102135088053; D. Boodhram, 5 Dolphin Centre, corner of Escombe and Bazley Streets, P.O. Box 1456, Port Shepstone, 4240. 30 June 1984, 10h00, Port Shepstone.
 UC39432—Bowbells (Pty) Ltd, in voluntary liquidation; Stanley Howard Jones, 1000 Parkade, Strand Street, Cape Town, 8001.
 T666/84—Contract Caterers (Pty) Ltd; Noel Herbert van der Merwe, 12th Floor, Nedfin Place, 53 Simmonds Street, Johannesburg.
 T443/84—L.E.C. Massiv-Schnellbau (S. Tvl) (Pty) Ltd, in liquidation; Dr O. F. C. Herrigel, c/o Security Trust SWA (Pty) Ltd, P.O. Box 3599, Windhoek, 9000. 25 June 1984, 10.00 a.m., Pretoria.
 N511/83—Sheik, Mustapha, 37 Kadirvel Road, Northdale, Pietermaritzburg; M. J. Ensor, c/o Metboard (Natal) Ltd, P.O. Box 3912, Durban, 4000. 29 June 1984, 10h00, Pietermaritzburg.
 N432/83—Budu, Harilal, Penindale Township, Mooi River, Natal; M. J. Ensor, c/o Metboard (Natal) Ltd, P.O. Box 3912, Durban, 4000. 28 June 1984, 10h00, Mooi River.
 T2063/83—Salsim Engineering (Pty) Ltd, in liquidation; I. Bekker, c/o Deloitte Haskins & Sells Trust (Pty) Ltd, P.O. Box 4785, Johannesburg, 2000. 20 June 1984, 09h00, Johannesburg.
 N495/83—W.L. Engineering (Pty) Ltd, in liquidation; Edward Hare Moore, P.O. Box 16, Vryheid, 3100. 25 June 1983, 10h00, Vryheid.
 C237/84—N. Rutstein Investments (Pty) Ltd, in voluntary liquidation; F. H. Kilham, P.O. Box 2275, Cape Town, 8000. 21/5/84, Cape Town.
 B3/84—Vosloo, Gerhardus Petrus Johannes; H. G. van der Walt, p/a McIntyre & Van der Post, SA Permanentegebou, Maitlandstraat 45, Posbus 540, Bloemfontein. 22 Junie 1984, 10h00, Bethlehem.
 T727/84—Laas, Johannes Bernardus Wessels; J. H. van Blerk en G. F. Wessels, Posbus 1636, Pretoria, 0001. 25/6/84, 10h00, Pretoria.
 T321/83—Hartbok Beleggings (Edms.) Bpk., in likwidasie; J. H. van Blerk, Posbus 1636, Pretoria, 0001. 19/6/84, 10h00, Brits.
 C757/83—Ansell, Colin John, born on 8/9/47, Identity No. 4709085007005; C. R. S. Gooden and G. S. Walker, for Coopers & Lybrand, 10th Floor, Shell House, 9 Riebeeck Street, Cape Town. 14 June 1984, 9 a.m., Wynberg.
 T1373/83—Pumpkin Patch (Pty) Ltd; P. J. Niewoudt, P.O. Box 62016, Marshalltown, 2107. 20/6/84, 09h00, Johannesburg.
 T1470/83—K.B. Sales Company (Pty) Ltd; G. E. Taylor, P.O. Box 62016, Marshalltown, 2107. 20/6/84, 09h00, Johannesburg.
 T848/83—Builders (Pty) Ltd; Martin Ian Stein, P.O. Box 1470, Pretoria.
 T754/84—A. D. Cook & Co. Consultants (Pty) Ltd; Martin Ian Stein, P.O. Box 1470, Pretoria.

Vorm/Form 2

BYEENKOMS VAN SKULDEISERS IN GESEKWESTREERDE BOEDELS OF MAATSKAPPYE IN LIKWIDASIE

Ingevolge artikels 41 en 42 van die Insolvensiewet, 1936, artikels 179 en 182 van die Maatskappywet, 1926, en artikels 339 en 366 van die Maatskappywet, 1973, word hierby kennis gegee dat 'n byeenkoms van skuldeisers in die gesekwestreerde boedels of maatskappye in likwidasie hieronder vermeld, gehou sal word met aanduiding van die nommer van boedel/maatskappy; die naam en beskrywing van boedel/maatskappy; die datum, uur en plek van byeenkoms en die doel van byeenkoms.

In 'n plek waarin 'n kantoor van 'n Meester is, word die byeenkoms voor die Meester en in ander plekke voor die Landdros gehou.

MEETING OF CREDITORS IN SEQUESTERED ESTATES OR COMPANIES BEING WOUND UP

Pursuant to sections 41 and 42 of the Insolvency Act, 1936, sections 179 and 182 of the Companies Act, 1926, and sections 339 and 366 of the Companies Act, 1973, notice is hereby given that a meeting of creditors will be held in the sequestrated estates or companies being wound up mentioned below, indicating the number of estate/company; the name and description of estate/company; the date, hour and place of meeting and the purposes of meeting.

Meetings in a place in which there is a Master's Office, will be held before the Master; elsewhere they will be held before the Magistrate.

- C539/83—Hart, J. H. J., Identiteitsnommer 3311035026002, gebore 3/11/33, 27/6/83, 10h00, Ceres. Bewys van eise en ondervraging van getuies.
- C670/82—Matthee, Elbe. 22/6/84, 09h00, Cape Town. Proof of claims.
- C731/83—Jones, R. G. 21/6/84, 09h00, Wynberg. Proof of claims.
- K19/83—I. Scorgie Steel Enterprises (Pty) Ltd, in likwidasie. 20 Junie 1984, 10 vm., Kimberley. Verdere bewys van eise.
- B303/83—Du Plooy, Petrus Albertus, voorheen van p/a Bekker Vervoer (Edms.) Bpk., Bethlehem en tans woonagtig te Marzandahof 5, Bethlehem. 22 Junie 1984, 09h30, Bethlehem. Bewys van verdere eise.
- E45/83—Buffalo Park Townships (Pty) Ltd, in liquidation. 21 Junie 1984, 2 p.m., Port Elizabeth. Proof of debt.
- K41/83—Grobbeelaar, L. J. van Wyk. 13 Junie 1984, 10h00, Kimberley. Verdere bewys van eise.
- B26/83—Van Rooyen, Johannes Jacobus, woonagtig te Du Plessisstraat 16, Bethlehem. 15 Junie 1984, 09h30, Bethlehem. Bewys van verdere eise.
- T1569/82—Van Eeden, Abraham Johannes Lodewyk, trading as Van Eeden Staalwerke. 1984-06-20, 10h00, Potchefstroom. To prove further claims.
- B47/83—Koorts, Sarel Johannes Jacobus, wat woonagtig was te Rurhstraat 46, Sasolburg en wat handel gedryf het as Sarita's Flooring, Vanderbijlpark. 25 Junie 1984, 10h00, Sasolburg. Bewys van verdere eise.
- T2087/83—Le Roux, Johannes Hendrik 'n boer van die plaas Gedeelte 5, De Hoop, distrik Delareyville. 22 Junie 1984, 08h30, Delareyville. Bewys van verdere eise.
- B194/83—Thuynsma, Zacharias Andries, gebore 11 Oktober 1983. 20 Junie 1984, 10 vm., Hoopstad. Om verdere eise te bewys.
- B286/83—Pelser, J. P. 20 Junie 1984, Welkom. Om verdere eise te bewys.
- T480/83—Germiston Gas Installations (Pty) Ltd, in liquidation. 22 Junie 1984, 9.30 a.m., Germiston. Further proof of claims.
- C156/83—Ryalson Engineering (Pty) Ltd, in liquidation. 22 Junie 1984, 9.00 a.m., Cape Town. For proof of claims.
- C457/83—Strand Merchandise (Pty) Ltd, in liquidation. 22 Junie 1984, 09h00, Cape Town. Further proof of claims.
- C578/83—Maree, Gerhard Johannes, born 31/12/44, Identity number 4412315006000. 22 Junie 1984, 09h00, Cape Town. Proof of claims.
- C13/83—Huijzers, Frederik Johannes. 19 Junie 1984, 11 a.m., Bellville. Further proof of claims.
- C499/80—Karjiek, Osman Abdurahman. 22 Junie 1984, 9.00 a.m., Cape Town. For proof of claims.
- T1038/82—Shepherd, E. W. 22 Junie 1984, 09h00, Tzaneen. 1. Bewys van eise. 2. Ondervraging van die insolvent ingevolge artikel 65 van die Insolvensiewet No. 24 van 1936, soos gewysig.
- T493/83—Botswana Safaris (Pty) Ltd, in liquidation. 20/6/84, 9.00 a.m., Johannesburg. Proof of claims.
- T1556/83—Locke, L. H. 20/6/84, 09h00, Johannesburg. Further proof of claims.
- T1201/82—Rand Precision (Pty) Ltd, in liquidation. 25 Junie 1984, 10h00, Pretoria. Further proof of claims.
- T1583/81—Fernwest Transport (Pty) Ltd, in liquidation. 22 Junie 1984, 09h30, Krugersdorp. Further proof of claims.
- T1842/82—Lkbo de Print (Pty) Ltd, in liquidation. 20 Junie 1984, 10h00, Randburg. Further proof of claims.
- T491/83—Gunsta Construction (Pty) Ltd, in liquidation. 20 Junie 1984, 10h00, Benoni. Further proof of claims.
- T678/83—Hawken Zahn (Pty) Ltd, in liquidation. 20 Junie 1984, 10h00, Benoni. Further proof of claims.
- T1091/83—Keith, Ronald McGregor. 20 Junie 1984, 10h00, Benoni. Further proof of claims.
- T769/83—Briggs, M. 20 Junie 1984, 09h00, Johannesburg. Further proof of claims.
- T655/83—Hiscock, J. G. 20 Junie 1984, 09h00, Johannesburg. Further proof of claims.
- T1607/83—Concept Furniture Products (Pty) Ltd, in liquidation. 20 Junie 1984, 09h00, Johannesburg. Further proof of claims.
- T712/83—Steam Easy (Pty) Ltd, in liquidation. 20 Junie 1984, 09h00, Johannesburg. Further proof of claims.
- T1256/82—Bezuidenhout, Rudolf Christoffel. 15 Junie 1984, 10h00, Pretoria. Proof of further claims.
- T2058/83—Pretorius, J. A. 29/6/84, 10h00, Schweizer-Reneke. Further proof of claims.
- T2250/83—Van der Walt, K. P. 28/6/84, 10h00, Potgietersrus. Further proof of claims.
- T1901/83—Schroder, G. M. 27/6/84, 10h00, Roodepoort. Further proof of claims.
- T2234/83—Combrinck, J. F. 27/6/84, 10h00, Middelburg. Further proof of claims.
- E103/83—Harrison, Ian Dugald, formerly trading as Fridge Foods. 21 Junie 1984, 2 p.m., Port Elizabeth. Proof of debt.
- N190/83—Chadun Alloys (Pty) Ltd, in liquidation. 20 Junie 1984, 09h00, Durban. Proof of claims obtaining the directions of creditors for the purpose of holding an interrogation.
- N119/83—Jacobs, C. J. 20/6/84, 09h00, Durban. Proof of claims.
- N407/82—PSI Yachts (Pty) Ltd, in liquidation. 20/6/84, 09h00, Durban. Proof of claims.
- N476/82—Golden Age International (Pty) Ltd, in liquidation. 20 Junie 1984, 09h00, Durban. Proof of claims.
- N256/83—Terra Tanks (Pty) Ltd, in liquidation. 20/6/84. Proof of claims.
- N85/83—Keen & Hodge Construction (Pty) Ltd, in liquidation. 20/6/84, 09h00, Durban. Proof of claims.
- E175/83—Clark, D. A., who formerly traded in partnership with G. P. Ceronio and C. C. W. Pretorius under the style of M. P. Engelbrecht and Son. 21 Junie 1984, 2 p.m., Port Elizabeth. Proof of debt.
- C472/83—Wolfsohn, Hyman Isaac, a wholesale merchant residing at 6 Holmfurth Road, Sea Point, Cape, ID No. 3509225080008, date of birth 22/9/35. 29/6/84, 9.00 a.m., Cape Town. Proof of claims.
- B276/83—Landkrag Slaghuis (Edms.) Bpk., handeldrywende as Boshof Slaghuis, in likwidasie. 20 Junie 1984, 10h00, Boshof. Spesiale vergadering vir bewys van eise.
- B223/83—Krause, Christiaan Frederick. 20 Junie 1984, 10h00, Virginia. Spesiale vergadering vir bewys van eise.
- E133/83—Ehlers, Jan Hendrick. 21 Junie 1984, 2 p.m., Port Elizabeth. Proof of debt.
- B245/83—Jordaan, Jakobus Johannes, Waterkantstraat, Odendaalsrus, voorheen van die plaas Magdalena, distrik Reitz. 18 Junie 1984, 10h00, Odendaalsrus. Bewys van verdere eise.
- T2110/83—Coetzee, Christoffel Johannes, 'n boer van die plaas Broedersput, Delareyville. 22 Junie 1984, 08h30, Delareyville. Bewys van verdere eise.
- B81/83—Nabal, Deon Johan, werksaam te Carletville en woonagtig te Rushofwoonstelle 2, Waterstraat, Parys. 20 Junie 1984, 09h30, Parys. Bewys van verdere eise.
- B227/83—Douglas, F. J. 4 Julie 1984, 10 vm., Welkom. Spesiale vergadering. Bewys van verdere eis.
- B119/83—Joubert, Theodora. 21/6/84, 10h00, Bloemfontein. Verdere bewys van eise.
- N420/83—Anderson, Graham Robert. 28/6/84, 10h00, Pinetown. Verdere bewys van eise.
- N513/83—Byroo, Prakash. 29/6/84, 10h00, Pietermaritzburg. Verdere bewys van eise.
- N415/83—De Lange, Dewald Heinrich. 29/6/84, 10h00, Pietermaritzburg. Verdere bewys van eise.
- N504/83—Ellary, Govindasamy. 29/6/84, 10h00, Pietermaritzburg. Verdere bewys van eise.
- N361/83—Gopal, Raja. 29/6/84, 10h00, Pietermaritzburg. Verdere bewys van eise.
- N390/83—Hemraj, Lorraine Joan. 27/6/84, 09h00, Durban. Verdere bewys van eise.
- N438/83—Rhodes, Diana Rosemary. 27/6/84, 09h00, Durban. Verdere bewys van eise.
- N408/83—Cro-Magnon (Tvl) (Pty) Ltd, in likwidasie. 27/6/84, 09h00, Durban. Verdere bewys van eise.
- N6/84—Debretts Umhlanga (Pty) Ltd, in likwidasie. 27/6/84, 09h00, Durban. Verdere bewys van eise.
- N268/82—Sylvercrest SA (Pty) Ltd, in likwidasie. 27/6/84, 09h00, Durban. Verdere bewys van eise.
- T1127/82—Sparklen Industrial Cleaning (Pty) Ltd, in liquidation. 1984-06-22, 10h00, Vanderbijlpark. To prove further claims and interrogate witnesses.
- T21/84—De Lange, A. D. L. 29/6/84, 9 vm., Westonaria. Bewys van eise.
- T1820/83—Benade, J. T. 15/6/84, 10 vm., Pretoria. Bewys van eise.

- T1808/83—Pret Pools (Edms.) Bpk., in likwidasie. 29/6/84, 10 vm., Pretoria. Bewys van eise.
 T1703/84—Venter, G. 12/6/84, 9 vm., Tzancen. Bewys van eise.
 T1966/82—Pleterse, A. 22/6/84, 10 vm., Vanderbijlpark. Bewys van eise.
 T1514/83—Gavs of Witbank (Edms.) Bpk., in likwidasie. 22/6/84, 10 vm., Witbank. Bewys van eise.
 T1782/83—Koen, T. J. 20/6/84, 10 vm., Potchefstroom. Bewys van eise.
 T20/84—V. d. Walt, P. J. 20/6/84, 10 vm., Potchefstroom. Bewys van eise.
 T1198/83—Daziël, T. A. 20/6/84, 10 vm., Klerksdorp. Bewys van eise.
 T1206/83—Van Bljjon, B. J. 20/6/84, 10 vm., Rustenburg. Bewys van eise.
 T1296/82—Harmse, C. J. 22/6/84, 8.30 vm., Delareyville. Bewys van eise.
 T1050/83—Grobler, J. 15/6/84, 10 vm., Vereeniging. Bewys van eise.
 E108/83—Trustor Manufacturing Industries (Pty) Ltd, in liquidation, with registered office at c/o Drake, Flemmer, Orsmond & Vermaak, Fifth Floor, Natal Building, Society Building, 15 Terminus Street, East London. 22 June 1984, 10 a.m., East London. Further proof of claims.
 E124/83—Likon (Pty) Ltd, in liquidation, livestock speculators with registered office at 33 Church Street, Colesberg, C.P. 22 June 1984, 10 a.m., Colesberg. That the liquidator be hereby authorised to:
 1. Institute legal proceedings in the Supreme Court of South Africa for the recovery of a debt of R49 504,80 from Mr A. P. P. Olivier, alternatively Johina (Pty) Ltd, alternatively Mr A. P. P. Olivier & Johina (Pty) Ltd, jointly; and to
 2. Sequesterate, liquidate, investigate, compromise, or abandon any claims either in favour of or against the company. Further proof of claims.
 E208/83—Strauch, Neville, trading as Surelight Electrical, 5 Lancaster Lane, Port Alfred. 27 June 1984, 10 a.m., Port Alfred. Further proof of claims.
 T1430/82—Interlease Ltd, in likwidasie. 27 Junie 1984, 09h00, Johannesburg. Ondervraging van getuies en verdere bewys van eise.
 T2145/83—Kameith Automotive (Pty) Ltd, in likwidasie. 27 Junie 1984, 09h00, Randburg. Verdere bewys van eise.
 T978/83—Venter, P. J. Jr., handeldrywende as Lushof Ondernemings. 22/6/84, 10h00, Pretoria. Bewys van eise.

Vorm/Form 3

VERLENGING VAN TERMYN VIR INDIENING VAN LIKWIDASIE-, DISTRIBUSIE- OF KONTRIBUSIEREKENINGS IN GESEKWESTREERDE BOEDELS OF MAATSKAPPYE IN LIKWIDASIE

Ingevolge artikel 109 (1) van die Insolvensiewet, 1936, en artikel 135 (1) (c) van die Maatskappywet, 1926, word hierby kennis gegee dat kurators of likwidateurs van die gesekwestreerde boedels of maatskappye in likwidasie, na gelang van die geval, hieronder vermeld voornemens is om na afloop van 'n termyn van 14 dae vanaf die datum van publikasie hiervan, die betrokke Meesters om 'n verlenging van die termyn hieronder genoem, vir die indiening van likwidasie-, distribusie- of kontribusierekenings te versoek.

Die besonderhede word verstrek in die volgorde: Nommer van boedel/maatskappy; naam en beskrywing van boedel/maatskappy; naam en datum van aanstelling van kurator of likwidateur; datum waarop rekening ingedien moet word; termyn van verlangde verlenging en by watter Meester aansoek gedoen sal word.

EXTENSION OF TIME WITHIN WHICH TO LODGE LIQUIDATION ACCOUNTS AND PLANS OF DISTRIBUTION OR CONTRIBUTION IN SEQUESTERED ESTATES OR COMPANIES BEING WOUND UP

Pursuant to section 109 (1) of the Insolvency Act, 1936, and section 135 (1) (c) of the Companies Act, 1926, notice is hereby given that after the expiration of a period of 14 days as from the date of publication hereof, it is the intention of the trustees or liquidators, as the case may be, of the sequestered estates or companies being wound up mentioned below, to apply to the respective Masters for an extension of time, as specified below, within which to lodge liquidation accounts and plans of distribution or contribution.

The particulars are given in the following order: Number of estate/company; name and description of estate/company; name and date of appointment of trustee or liquidator; date when account due; period of extension required and to which Master application will be made.

- N292/83—Scheepers, Frederick Richard Coenraad, I.D. No. 2508315049007, born 31/8/25; Edward Hare Moore, 22 September 1983. 12 April 1984. Pietermaritzburg, three months.
 N254/83B—Vishnu, Seegobin; A. D. Wilkins, 13/9/83. 31/5/84. Pietermaritzburg, three months.
 N254/83—Seegobin, V. and Orlee R., formerly trading as Repco Construction; A. D. Wilkins, 13/9/83. 31/5/84. Pietermaritzburg, three months.
 N254/83C—Orlee, Ram; A. D. Wilkins, 13/9/83. 31/5/84. Pietermaritzburg, three months.

Vorm/Form 4

LIKWIDASIE-, DISTRIBUSIE- OF KONTRIBUSIEREKENINGS IN GESEKWESTREERDE BOEDELS OF MAATSKAPPYE IN LIKWIDASIE

Ingevolge artikel 108 (2) van die Insolvensiewet, 1936, artikel 136 (2) van die Maatskappywet, 1926, en artikel 406 (3) van die Maatskappywet, 1973, word hierby kennis gegee dat die likwidasie-, distribusie- of kontribusierekenings in die boedels of die maatskappye, na gelang van die geval hieronder vermeld, ter insae van skuldeisers of kontribuante sal lê op die kantore van die Meesters en Landdroste daarin genoem, gedurende 'n tydperk van 14 dae, of die tydperk wat daarin vermeld is, vanaf die datum hieronder vermeld of vanaf die datum van publikasie hiervan, watter datum ook al die laatste is.

Die besonderhede word verstrek in die volgorde: Nommer van boedel/maatskappy; naam en beskrywing van boedel/maatskappy; beskrywing van rekening; rekening ter insae by Meester- en Landdroskantoor, datum (indien later as publikasiedatum), tydperk (indien langer as 14 dae).

LIQUIDATION ACCOUNTS AND PLANS OF DISTRIBUTION OR CONTRIBUTION IN SEQUESTERED ESTATES OR COMPANIES BEING WOUND UP

Pursuant to section 108 (2) of the Insolvency Act, 1936, section 136 (2) of the Companies Act, 1926, and section 406 (3) of the Companies Act, 1973, notice is hereby given that the liquidation account and plans of distribution or contribution in the estates or the companies mentioned below will lie open for inspection by creditors or contributories at the offices of the Masters and the Magistrates stated therein, for a period of 14 days, or for such a period as stated therein, from the date mentioned below or from the date of publication hereof, whichever may be the later date.

The particulars are given in the following order: Number of estate/company; name and description of estate/company; description of account; account for inspection at Master's and Magistrate's Office, date (if later than date of publication hereof), period (if longer than 14 days).

- B132/82—Hoole, Leslie Douglas Boucher. Aanvullende tot die Eerste en Finale Likwidasië en Distribusie. Bloemfontein, Virginia.
 T769/82—Stellanine (Pty) Ltd, in voluntary liquidation. First and Final Liquidation and Distribution. Pretoria.
 T899/83/OND 11/b—Bris Properties (Pty) Ltd, in voluntary liquidation. Pretoria, Johannesburg.
 E68/83/2B—Invercargill Investments (Pty) Ltd, in voluntary liquidation. Supplementary Liquidation and Distribution. Grahamstown, East London.
 B170/82—Henderson, H. J.. Eerste en Finale Likwidasië en Distribusie. Bloemfontein, Virginia.
 B182/83—Carr, Neil Garth Denzill. Eerste en Finale Likwidasië en Kontribusie. Bloemfontein, Koffiefontein.
 T690/79—Diamond, Cyril Ishrol. Sixth and Final Liquidation. Pretoria, Johannesburg.
 T280/82—Volkskas Eiendoms Trust (Edms.) Bpk., in likwidasië. Eerste en Finale Likwidasië en Distribusie. Pretoria.
 T793/81—Vitamol Centre (Pty) Ltd, in liquidation. First and Final Liquidator's Liquidation and Contribution. Pretoria, Johannesburg, 8 June 1984.
 K37/83—Jacobs, Frederick Johannes, 'n boer van die plaas Vyflingspan, distrik Vryburg. Eerste Likwidasië en Distribusie. Kimberley, Vryburg.
 B220/83—A J Beleggings (Edms.) Bpk., in likwidasië, handeldrywende as Fides Engineering te Maasdorpstraat 21, Bloemfontein. Gewysigde Eerste en Finale Likwidasië en Distribusie. Bloemfontein.
 K39/83—McLachlan, J. Eerste en Finale Likwidasië en Distribusie. Kimberley, Olifantshoek.
 T1653/83—Weight Control Centres (Jhb) (Pty) Ltd. First and Final Liquidation. Pretoria, Johannesburg.
 B109/83—Randall, Johannes Christoffel. Eerste en Finale Likwidasië en Kontribusie. Bloemfontein, Odendaalsrus.
 B237/83—Jan Pienaar Boerderye (Edms.) Bpk., in members' voluntary liquidation. First and Final Liquidation. Bloemfontein.
 T1542/75—Burger, Johannes Diederick, Elandsfontein, distrik Potchefstroom. Tweede Aanvullende Likwidasië en Distribusie. Pretoria, Potchefstroom.
 B247/83—Bayswater Enterprises (Pty) Ltd, in liquidation. Second and Final Liquidation and Distribution. Bloemfontein, Viljoenskroon.
 T1472/83—Zallgerex (Pty) Ltd, in voluntary liquidation. First and Final Liquidation and Distribution. Pretoria, Johannesburg, Roodepoort.
 T596/83—Four United Tool and Die Makers (Pty) Ltd, in liquidation. First and Final Liquidation and Distribution. Pretoria, Johannesburg.
 K36/83—Dry, Gert Christiaan, 'n boer van die plaas Weltevrede, Vryburg. Eerste Likwidasië en Distribusie. Kimberley, Vryburg.
 B76/83—Schultz, Norman Teddy, Smaldeel, distrik Lindley. Eerste en Finale Likwidasië en Distribusie. Bloemfontein, Lindley.
 B171/80—Vermaak, Johannes Petrus, gebore 25 Maart 1957. Eerste Supplementêre tot die Eerste en Finale Likwidasië en Distribusie. Bloemfontein, Brandfort.
 B179/83—Van der Westhuizen, Petrus Cornelius, gebore 18 Junie 1943. Eerste en Finale Likwidasië en Distribusie. Bloemfontein.
 T258/83/OND 8B—Bousaam Diesel (Pty) Ltd, in voluntary liquidation. First and Final Liquidation and Distribution. Pretoria, Johannesburg.
 T255/83/OND 11/B—United Audio Distributors (Pty) Ltd, in voluntary liquidation. First and Final Liquidation and Distribution. Pretoria, Johannesburg.
 T1482/82/OND 2/B—Joman Properties (Pty) Ltd, in voluntary liquidation. First and Final Liquidation and Distribution. Pretoria, Johannesburg, 8 June 1984.
 N352/83/1B—Edaff (Pty) Ltd. First and Final Liquidation and Distribution. Pietermaritzburg, Durban, 8 June 1984.
 B122/83—Du Preez, Pieter Jacobus. Eerste en Finale Likwidasië en Distribusie. Bloemfontein.
 C548/82—Algray Roofing (Pty) Ltd, in liquidation. First Liquidation and Distribution. Cape Town, Durban.
 C53/77—Dalwai, Ismail. Tweede en Finale Likwidasië. Worcester.
 T178/84—Alwil Body and Coach Builders (Pty) Ltd, in liquidation. First and Final Liquidation and Distribution. Pretoria, Johannesburg.
 C221/81—Indax Africa (Pty) Ltd, in liquidation. Supplementary Second and Final Liquidation and Distribution. Cape Town.
 T1234/79/3A—Dimltri, P. R. First and Final Liquidation. Pretoria.
 C495/81/5A—Parker, Nazir Ahmed, born 29/5/47. First Liquidation and Distribution. Cape Town, Wynberg.
 T1472/79/OND/2B—Exporttrader (Pty) Ltd, in liquidation. First Liquidation and Contribution. Pretoria, Johannesburg.
 C559/80/6A—Kleynhans, Christiaan. Supplementary Liquidation and Distribution. Cape Town.
 C455/79/5A—V S U B Investments (Pty) Ltd, in voluntary liquidation. Supplementary Liquidation and Distribution. Cape Town.
 C36/83/6A—Afro Duth Construction (Pty) Ltd, in liquidation. Amended First and Final Liquidation and Distribution. Cape Town.
 C366/74—Spaarsaam Bouers (Pty) Ltd, in liquidation. Fourth and Final Liquidation and Distribution. Cape Town, Bellville.
 T1008/82—V & A Bear Investments (Pty) Ltd, in voluntary liquidation by way of members' voluntary winding-up. First and Final Liquidation and Distribution. Pretoria, Johannesburg, 14 days.
 E130/77/1A—Attwood, Bertram Cave Gordon, a building contractor who resided at 6 Brunfelsia Road, Vincent Heights, East London. Fourth Supplementary, Second and Final Liquidation and Distribution. Grahamstown, East London.
 E94/82/2B—Hill, Robin Leonard, Identity number 5904175119005, a farmer formerly of Mikia Farm, P.O. Box 28, Komga, Kwelegha, District of East London. Supplementary Second and Final Liquidation and Distribution. Grahamstown, East London.
 C626/82—Joubert, Andries Johannes, 103 Chateaux Lynn, Farmer's Folly, Lynnwood, Pretoria, Identity number 4909145008007, born 14/9/49. First and Final Liquidation, Distribution and Contribution. Cape Town.
 C440/82/4A—Paul, Trevor Blake, born 12/12/47. First Liquidation and Distribution. Cape Town, Wynberg.
 C182/83—Vortex Products (Pty) Ltd. First Liquidation and Distribution. Cape Town, 15/6/84.
 C629/81—Bester, Ronald Bertram, formerly trading as Markdown Carpets, now residing at Cesares, Bisshof Road, Hout Bay. Fourth Liquidation and Distribution. Cape Town, 15/6/84.
 C33/83—Du Plessis, Hendrik Johannes, born on 23/1/27, married out of community of property to Anika Violet Petru du Plessis, born De Villiers, formerly trading as Meubelentrum, Worcester, and residing at 27 Le Seur Street, Rawsonville. First and Final Liquidation and Distribution. Cape Town, Worcester, 15/6/84.
 C33/69—Meyer, Lily, born Ravden, married without community of property to Bertram Lester Meyer, 87 Sandown Road, Rondebosch, C.P. Second and Final Liquidation and Distribution. Cape Town.
 N267/83—Westville Two Four Seven Four (Pty) Ltd. First and Final Liquidation. Pietermaritzburg, Durban, 8 June 1984.
 N83/83/2B—Miranda Pipelines & Construction (Pty) Ltd, in liquidation. Second and Final Liquidation and Distribution. Pietermaritzburg, Durban.
 N256/83/3B—Terra Tanks (Pty) Ltd, in liquidation. First Liquidation. Pietermaritzburg, Durban.
 N366/83/3B—Buytendag, B., trading as Bluff Hobbies. First and Final Liquidation and Distribution. Pietermaritzburg, Durban.
 N105/80—Gas & Equipment Centre (Pty) Ltd, in liquidation. Fourth Liquidation and Distribution. Pietermaritzburg, Durban.

- N212/82—**Abrasive Blasting Development (Pty) Ltd**, in liquidation. Second and Final Liquidation and Distribution. Pietermaritzburg, Durban, Johannesburg.
- N20/82/1B—**J. A. Leisegang Investments (Pty) Ltd**. First and Final Liquidation and Distribution. Pietermaritzburg, Durban.
- N365/83—**Langston, G.** First and Final Liquidation and Distribution. Pietermaritzburg, Durban.
- N221/83/1B—**El Burn (Pty) Ltd**, in voluntary liquidation. First and Final Liquidation and Distribution. Pietermaritzburg, Durban.
- N321/83/1B—**Mackays Investments (Glencoe) (Pty) Ltd**, in members' voluntary liquidation. First and Final Liquidation and Distribution. Pietermaritzburg, Durban, Pinetown.
- N322/83/1B—**Lewaron Properties (Pty) Ltd**, in members' voluntary liquidation. First and Final Liquidation and Distribution. Pietermaritzburg, Durban, Pinetown.
- E22/83—**P.L.B. Furnishers (Pty) Ltd**, in liquidation, a dealer in furniture and household goods under the name and style of Phil's Furnishers, 303 Cape Road, Newton Park, Port Elizabeth. First Liquidation and Distribution. Grahamstown, Port Elizabeth.
- E163/83/1B—**Bedford Pharmacy (Pty) Ltd**, in voluntary liquidation. First and Final Liquidation and Distribution. Grahamstown, Port Elizabeth.
- B/38/83/B—**Stoomhoek Vervoer (Edms.) Bpk.**, in vrywillige likwidasië. Eerste en Finale Likwidasië, Distribusie en Kontribusie. Bloemfontein.
- C531/83—**Boston House (Strand Street) (Pty) Ltd**, in voluntary liquidation. First and Final Liquidation and Distribution. Cape Town.
- B137/83—**Du Plessis, Calvyn Pieter**. First and Final Liquidation and Distribution. Bloemfontein, Welkom.
- N475/83—**Shelaine (Pty) Ltd**, in member's voluntary winding-up. First and Final Liquidation and Distribution. Pietermaritzburg, Port Shepstone.
- T127/83—**Van Broekhuizen Beleggings (Edms.) Bpk.**, in vrywillige likwidasië deur lede. Eerste en Finale Likwidasië en Distribusie.
- N314/83—**Cool-O-Matic (Pty) Ltd**, in liquidation. First Liquidation and Distribution. Pietermaritzburg, Durban.
- N384/83—**Shraga, Alex Benjamin**, 11 Lyngarth Park, Nyala Road, Kloof, Natal. First Liquidation and Distribution. Pietermaritzburg, Pinetown.
- N398/83—**Ramdass, Vinay Rajkumar**. First Liquidation and Distribution. Pietermaritzburg, Durban.
- T785/80—**Myburg, J. P.** Amended First and Final Liquidation and Distribution. Pretoria, Vereeniging.
- C302/78—**Swartland Cement Works (Edms.) Bpk.** Sesde Likwidasië en Distribusie. Kaapstad, Malmesbury.
- N497/83—**Kolandene Properties (Pty) Ltd**, in voluntary liquidation. First Liquidation and list of amounts returnable to contributors. Pietermaritzburg, Durban.
- B13/83/C—**Hexview (Pty) Ltd**, in voluntary liquidation. First and Final Liquidation and Distribution. Bloemfontein.
- K17/83—**Noord-Kaap Petroleum Produkte (Edms.) Bpk.** Eerste en Finale Likwidasië en Distribusie. Kimberley.
- C240/83—**Lean, Jonathan Edward**. First Liquidation and Distribution. Cape Town, Simon's Town, 8 June 1984.
- T151/81—**Elite Services (Pty) Ltd**, in liquidation. First and Final Liquidation and Distribution. Pretoria, Belfast.
- C175/83/5A—**Sandleigh Estates (Pty) Ltd**, in voluntary liquidation. First and Final Liquidation, Distribution and Contribution. Cape Town.
- T847/83—**Dorset Investment Co. (Pty) Ltd**, in voluntary liquidation. First and Final Liquidation and Distribution. Pretoria, Johannesburg.
- N278/79—**O'Keefe, William Joseph Carter**, a major male of Broadacres, Howick, Natal. Seventh Liquidation and Distribution. Pietermaritzburg, Howick.
- T318/83—**Venter, M. J. S.**, handeldrywende as Venter Transport. Eerste en Finale Likwidasië en Distribusie. Pretoria.
- T2001/82—**Highveld Brake and Clutch (Edms.) Bpk.** Eerste en Finale Likwidasië en Kontribusie. Pretoria.
- T1412/82—**Pambar Holdings (Pty) Ltd**, in voluntary liquidation. Second and Final Liquidation and Distribution. Pretoria.
- 53/2227—**Julius Penn Properties (Pty) Ltd**. First Liquidation. Pretoria, Johannesburg, 8 June 1984.
- T153/83—**Parkview Norman (Pty) Ltd**, in members' voluntary winding up. First and Final Liquidation and Distribution. Pretoria, Johannesburg.
- T598/81—**Atlas Estates (Pty) Ltd**, in voluntary liquidation. Liquidators' Liquidation Distribution and Contribution. Pretoria, Johannesburg.
- N196/82—**Meyer, A. C.** First and Final Liquidation and Distribution. Pietermaritzburg, Paulpietersburg.
- N195/82—**Meyer, J. E. M. F.** First and Final Liquidation and Distribution. Pietermaritzburg, Paulpietersburg.
- T69/83—**Swanepoel, Michael Ignatius**. First and Final Liquidation and Contribution. Pretoria.
- T1058/82—**Ultra Precision Engineering and Development (Pty) Ltd**, in liquidation. Second and Final Liquidation and Distribution. Pretoria.
- C507/83/1B—**Sher & Levy Investments (Pty) Ltd**. First and Final Liquidation and Distribution. Heetengracht.
- T696/81—**Marais, J. P. A.** Second and Final Liquidation and Distribution. Pretoria, Nelspruit.
- T1076/82—**Toolreps (Pty) Ltd**, in liquidation. First and Final Liquidation and Distribution. Pretoria, Witbank.
- T1579/83—**Abdool Latieb (Pty) Ltd**. Liquidation and Distribution. Pretoria, Pietersburg.
- T1150/79—**Erasmus, L. J.** Supplementary Liquidation and Distribution. Pretoria, Pietersburg.
- T223/83—**Beukes, C.** First Liquidation and Distribution. Pretoria, Evander.
- T82/83—**MaClear Good Hope Farms (Pty) Ltd**, in voluntary liquidation. First and Final Liquidation and Distribution. Pretoria, Johannesburg.
- N431/78—**Van der Merwe, Carla Cawood**. Supplementêre Likwidasië en Verdelings. Pietermaritzburg.
- T161/80—**Graphic (Pty) Ltd**. First and Final. Pretoria, Johannesburg.
- T72/81—**Goldman's Electrical Contractors (Pty) Ltd**, in likwidasië. Derde Likwidasië en Distribusie. Pretoria, Johannesburg.
- T831/83/AND1—**Hopley, J. J.** Eerste en Finale Likwidasië. Pretoria, Rustenburg.
- T841/83—**Van den Berg, P. A.** Eerste en Finale Likwidasië en Distribusie. Pretoria, Rustenburg.
- T899/82/11B—**Filmprint (Edms.) Bpk.**, in likwidasië. Tweede en Finale Likwidasië en Distribusie. Pretoria.
- T1687/82—**Rufekor (Pty) Ltd**, in liquidation. First Liquidation and Distribution. Pretoria.

Vorm/Form 5

UITKEER VAN DIVIDENDE EN INSAMELING VAN KONTRIBUSIES IN GESEKWESTREERDE BOEDELS OF MAATSKAPPYE IN LIKWIDASIE

Nademaal die likwidasiërekenings en distribusie- of kontribusierekenings in die gesekwestreerde boedels of maatskappye in likwidasië, na gelang van die geval, hieronder vermeld op die datums daarin vermeld, bekragtig is, word hierby ingevolge artikel 113 (1) van die Insolvensiewet, 1936, artikel 139 (2) van die Maatskappywet, 1926, en artikel 409 (2) van die Maatskappywet, 1973, kennis gegee dat uitbetaling van dividende of insameling van kontribusies aan die gang is in genoemde boedels of maatskappye soos hieronder uiteengesit en dat elke kontribusiepligtige skuldeiser die bedrag deur hom verskuldig by die adres hieronder genoem aan die kurator of likwidateur moet betaal.

Die besonderhede word verstrek in die volgorde: Nommer van boedel/maatskappy; naam en beskrywing van boedel/maatskappy en rekening; datum waarop rekening bekragtig is; of 'n dividend uitgekeer of 'n kontribusie ingevorder word, of beide, en naam en adres van kurator of likwidateur.

PAYMENT OF DIVIDENDS AND COLLECTION OF CONTRIBUTIONS IN SEQUESTERED ESTATES OR COMPANIES BEING WOUND UP

The liquidation accounts and plans of distribution or contribution in the sequestered estates or companies being wound up, as the case may be, mentioned below having been confirmed on the date therein mentioned, notice is hereby given, pursuant to section 113 (1) of the Insolvency Act, 1936, section 139 (2) of the Companies Act, 1926, and section 409 (2) of the Companies Act, 1973, that dividends are in the course of payment or contributions are in the course of collection in the said estates or companies as set forth below and that every creditor liable to contribution is required to pay to the trustee or liquidator the amount for which he is liable at the address mentioned below.

The particulars are given in the following order: Number of estate/company; name and description of estate/company and account; date when account confirmed; whether a dividend is being paid or contribution being collected, or both, and name and address of trustee or liquidator.

2;hr;fe

- K43/82—**Van Heerden**, Schalk Willem, handeldrywende as OK Kafee, Kuruman. Eerste en Finale Likwidasië en Verdeling. 15 Mei 1984. 'n Preferente dividend word betaal. J. W. Wilmans, p/a Elliott Maris Wilmans & Hay, Posbus 179, Cheapside, Kimberley.
- K31/83—**Eunice Motors (Edms.) Bpk.**, in likwidasië, handeldrywende te Kuruman. Eerste en Finale Likwidasië en Verdeling. 15 Mei 1984. Slegs preferente dividende word uitgekeer. J. W. Wilman, p/a Elliott Maris Wilmans & Hay, Cheapside, Posbus 179, Kimberley.
- T1479/82—**Maritz**, Frederick Christoffel. 7/5/84. Award to secured creditor only. C. P. van Zyl, c/o Highveld Trust and Management Co. (Pty) Ltd, P.O. Box 10463, Johannesburg, 2000.
- N295/82—**Long and Fleischman Motor Investments (Pty) Ltd**, in liquidation. 18/5/84. Award to secured creditors only. S. Trakman, c/o Highveld Trust and Management Co. (Pty) Ltd, P.O. Box 10463, Johannesburg, 2000.
- N322/82—**Le Clos**, Marie Jean Claude, born on 9/2/47. 18/5/84. Dividend being paid. S. Trakman, c/o Highveld Trust and Management Co. (Pty) Ltd, P.O. Box 10463, Johannesburg, 2000.
- B176/83—**Cronje**, Cecilia Francina, 17/5/84. Preferente en konkurrente dividende word uitgekeer. Charl Jacob Venter, p/a Naudes, Posbus 153, Bloemfontein.
- B125/83—**Van Wyk**, Pieter Willem Jacobus, Identiteitsnommer 4011035015000. 16/5/84. Preferente en konkurrente dividende word uitgekeer. C. J. Venter, p/a Naudes, Posbus 153, Bloemfontein.
- T324/82—**Siebert**, Hester Johanna Elizabeth. 10 May 1984. Dividend. Johline Steyn, P.O. Box 3578, Johannesburg, 2000.
- T551/80—**De Koning**, Benjamin Ulrich, 'n ambagsman en klerk van Kockstraat 71, Potchefstroom. 29 Maart 1984. Kontribusie. C. van Gass, Posbus 523, Potchefstroom.
- C519/80—**Allval Shoes (Pty) Ltd**, in liquidation. 9/5/84. Dividends being paid. M. Terblanche, 5 Cuff Street, P.O. Box 83, Mossel Bay.
- T1180/82—**Bouwer**, Andre Bresle. 1984-05-04. Dividend. J. G. R. Seagers, c/o Johannes Trust Co. (Pty) Ltd, P.O. Box 95177, Grant Park, 2051.
- C379/83/6B—**Acklands Holdings (Pty) Ltd**. 3 May 1984. Dividend paid. Herbert Arthur Farrow, Sixth Floor, Union Castle Building, St George's Street, Cape Town.
- B62/83—**Sharleen (Edms.) Bpk.**, in vrywillige likwidasië deur lede. Eerste en Finale Likwidasië en Distribusie. 3/4/84. Dividend. A. C. Marais, Posbus 818, Bloemfontein.
- B78/83—**Meyer**, Barend Gabriel, 'n boukontraakteur van Bontelsiestraat 1, Randparkrif, Randburg, en voorheen woonagtig te Wesselsbron. 2 Mei 1984. Uitkeer dividende en kontribusie te vorder. Roelof Davel du Plessis, Posbus 760, Bloemfontein.
- B60/83—**Allimar (Edms.) Bpk.**, in vrywillige likwidasië deur lede. Eerste en Finale Likwidasië en Distribusie. 9/5/84. Dividend. A. C. Marais, Posbus 818, Bloemfontein.
- B61/83—**Middelplaas Boerdery (Edms.) Bpk.**, in vrywillige likwidasië deur lede. Eerste en Finale Likwidasië en Distribusie. 26/3/84. Dividend. A. C. Marais, Posbus 818, Bloemfontein.
- T999/82—**Delamere Properties (Pty) Ltd**. 12/4/84. Dividend paid. J. Bloom, P.O. Box 11377, Johannesburg, 2000.
- B15/83—**Nieuwoudt**, Gideon Johannes, gebore 19 Februarie 1943. 15/5/84. Kontribusie word gevorder. Charl Jacob Venter, p/a Naudes, Posbus 153, Bloemfontein.
- B172/83—**Van Schalkwyk**, Philippus Lodewickus. 9/5/84. Konkurrente en preferente dividende word uitgekeer. Charl Jacob Venter, p/a Naudes, Posbus 153, Bloemfontein.
- C335/83—**Douglas Warwick Properties (Pty) Ltd**, in voluntary liquidation. 17/5/84. A dividend is being paid. R. A. Came, P.O. Box 2275, Cape Town, 8000.
- T2055/82—**Captain Video (Pty) Ltd**. 14/5/84. Contribution. P. J. E. Meintjes, P.O. Box 3425, Johannesburg, 2000.
- T1418/81—**Van der Merwe**, J. P. S., handeldrywende as Winskoop Onderdele. 14/5/84. Dividende. P. J. E. Meintjes, Posbus 3425, Johannesburg, 2000.
- B177/83—**Hilliar**, Darrell John. 15/5/84. Dividend being paid to preferent and concurrent creditors. Francis Joseph Errol Paola, c/o Gersohn Paola & Partners, P.O. Box 101, Kroonstad, 9500.
- C621/82—**Allied Roofing (Pty) Ltd**, in liquidation. 15/5/84. Payment of dividend. C. R. S. Gooden, for Coopers & Lybrand, P.O. Box 1913, Cape Town, 8000, and A. M. Rennie, for Syfrets Trust Ltd, P.O. Box 206, Cape Town, 8000.
- C369/83—**Kromboom Bottle Store (Pty) Ltd**, in voluntary liquidation. 9 May 1984. Dividends being paid. M. A. Brey, P.O. Box 221, Cape Town, 8000.
- C600/81—**Badenhorst**, Stephanus Johannes. 1 May 1984. Concurrent awards only. Lieb Johannes Rudolf van Jaarsveld, for Sanek Cape (Pty) Ltd, formerly Kaap Vaal Trust (Cape) (Pty) Ltd, Seventh Floor, Phoenix House, 42 Burg Street, Cape Town.
- C409/82—**Coolease (Pty) Ltd**, trading as Argyle Motors, in liquidation. 8/5/84. Dividend. A. M. Rennie & D. S. Ozinsky, for Syfrets Trust Ltd, 85 St George's Street, Cape Town.
- T561/82—**Barney's Bottle Store (1979) (Pty) Ltd**, in liquidation by way of members' voluntary winding-up. 17/4/84. Dividend being paid. Isaac Emanuel Sacks, P.O. Box 17785, Hillbrow, 2038.
- C46/82/6B—**Tract Aids (Pty) Ltd**, in liquidation. 3/5/84. Dividend being paid. J. N. Bekker, c/o The Board of Executors, 4 Wale Street, Cape Town, 8001.
- C290/82/5B—**Lovelace**, Terence Sidney Walter, born on 17/2/43. 11/5/84. Contribution levied. S. Gutman, for the Board of Executors, 4 Wale Street, Cape Town, 8001.
- C391/80/1A—**Electromotive Construction Co. (Pty) Ltd**, in liquidation. 4/5/84. Dividend being paid. S. Gutman, for The Board of Executors, 4 Wale Street, Cape Town, 8001.
- C422/82/2B—**Marba Holdings (Pty) Ltd**, in liquidation. 26/4/84. Contribution levied. Mrs R. H. D. Ingram, for The Board of Executors, 4 Wale Street, Cape Town, 8001.
- C723/82/3A—**Tony Hatton Carpet Wholesalers (Pty) Ltd**, in liquidation. 7 May 1984. Dividend being paid. Cape Town.
- T441/79/OND/1A—**Caldeira Liquor Mart (Pty) Ltd**, in liquidation, formerly trading as Court Hotel. 7/5/84. Dividend being paid. John Marais, c/o The Board of Executors, 4 Wale Street, Cape Town, 8001.
- T1473/82—**Domestic Rental (Pty) Ltd**, in voluntary liquidation. 4 April 1984. Amounts returned to contributors. M. G. Wessels, c/o E. F. K. Tucker Nupen & Goodman Inc., P.O. Box 100, Johannesburg.

- N158/79—Hurst, J. W. 14 May 1984. Dividend payable. B. Rulten, P.O. Box 135, Durban, 4000.
 N40/80—Dray, Bary M. 14/5/84. Dividend being paid. B. Rulten, P.O. Box 135, Durban, 4000.
 N402/80—Ranchoddas, N. J. 18/5/84. Dividend payable. B. Rulten, P.O. Box 135, Durban, 4000.
 N85/83/3A—Keen & Hodge Construction (Pty) Ltd, in liquidation. 18/5/84. Dividend paid. J. S. Evans, c/o Natal Trust Co. (Pty) Ltd, P.O. Box 5342, Durban, 4000.
 N305/83/3A—Goldton Radiator & Heater Core Manufacturers (Pty) Ltd, in liquidation. 18/5/84. Part secured award only. R. J. Strydom, c/o Natal Trust Co. (Pty) Ltd, P.O. Box 5342, Durban, 4000.
 N445/81—Yamoyani, G. 14/5/84. Dividend payable. B. Rulten, P.O. Box 135, Durban, 4000.
 E71/75—Redfern, Noël Buxton. 14 May 1984. Award being paid. Basil Kenneth Spengler Van Zyl, c/o Syfrets Trust Ltd, 94 Main Street, Port Elizabeth, 6001.
 B69/83—Du Plooy, Christoffel Petrus Jurie, Strappstraat 18, Mōrelig, Bethlehem. 21 Mei 1984. Uitkeer dividende. George Frederik Wessels, p/a Symington & De Kok, Posbus 760, Bloemfontein, 9300.
 C196/82/6B—Coppull Investments (Pty) Ltd, 15/5/84. Paid. L. E. Norman, P.O. Box 1000, Cape Town, 8000.
 C458/83—Chelsea Gardens (Pty) Ltd, in voluntary liquidation. 9/5/84. Return of capital and surplus to contributors. J. Tocker, Monex House, 47 Strand Street, Cape Town, 8001.
 C257/83—Maudike Properties (Pty) Ltd, in voluntary liquidation. 21/5/84. Set-off of shareholders loan accounts and cash distribution. A. B. H. Margolis, P.O. Box 1450, Cape Town, 8000.
 B104/83—Weydeman, Carel Johannes, Eerste en Finale Likwidasie en Distribusie. 7/5/84. Dividend uitkeer. F. B. Pretorius, p/a E. G. Cooper & Seuns, Posbus 27, Bloemfontein, 9300.
 C454/83—S. Raciti Builders (Pty) Ltd, in voluntary liquidation. 16 May 1984. Dividends paid. P. D. Holtzhausen, P.O. Box 4609, Cape Town, 8000.
 B141/81—Ladybrand Meubels (Edms.) Bpk., in likwidasie. Derde en Finale Likwidasie. 24 Mei 1984. Dividende betaalbaar. H. J. F. Steyn, Posbus 819, Bloemfontein.
 N119/80—Estcourt Developments (Pty) Ltd, in liquidation. 18 May 1984. A dividend will be paid. R. J. Strydom, c/o Metboard (Natal) Ltd, P.O. Box 3912, Durban, 4000.
 N204/82—Mall, Moosa, formerly trading as Miriam's Boutique, Identity No. 4208075091053, date of birth, 1942-08-07. 21 May 1984. Contribution. Bodraj Ganpath Singh, P.O. Box 907, Stanger.
 T803/83—Protea Development Company (Pty) Ltd, in voluntary liquidation. 22 May 1984. Dividend being paid. G. G. F. Stoltz, P.O. Box 2128, Pretoria.
 B180/83—Jonker, Francois Hendrik. 18/5/84. Preferente en dividende word uitgekeer. Charl Jacob Venter, p/a Naudes, Posbus 153, Bloemfontein.
 C555/82—Noordien, S. 14/5/84. Dividend being paid. L. von W. Bester, P.O. Box 1867, Cape Town.
 C685/83—Chamberlain, B. W. 11/5/84. Contribution being collected. L. von W. Bester, P.O. Box 1867, Cape Town.
 T283 OND 2B—Sandown Farm Dairy Holdings (Pty) Ltd, in voluntary liquidation. 2/12/83 and 22/5/84. Dividends being paid. A. D. Roberts, P.O. Box 31731, Braamfontein, 2017.
 T313/82—Harberg Investments (Pty) Ltd, 16/5/84. Dividend. Dave Oshry, Sixth Floor, Shakespeare House, 114/116 Commissioner Street, P.O. Box 6381, Johannesburg.
 B233/81—Gouws, Abraham Jacobus, woonagtig te Groblerstraat 30, Sasolburg, en werksaam as passer en draaier te Coalbrook Collieries, Coalbrook, Oranje-Vrystaat. 15/5/84. Uitkeer dividende. Roelof Davel du Plessis, Posbus 760, Bloemfontein.
 K9/81—Le Roux, Theodorus Louis, 'n boer van die plaas Cavers, distrik Piet Plessis. 17 Mei 1984. Dividende uitkeer. R. D. du Plessis, Posbus 760, Bloemfontein.
 C465/83—Cesyl Court (Pty) Ltd, 21/5/84. Dividend being paid. F. Lichtenstein, Fifth Floor, Shell House, 9 Riebeeck Street, Cape Town, 8001.
 C85/78—National Half Price Stores (Pty) Ltd, in liquidation. 14 May 1984. Dividend being paid. David John Rennie Rael Gordon, 85 St George's Street, Cape Town. Alexander Strelitz, 4 Rink Street, Port Elizabeth.
 T185/81—Evertred (Edms.) Bpk. 10 Mei 1984. Dividende uitgekeer. Leendert Jacobus Niemand, Posbus 583, Klerksdorp, 2570.
 B274/83—Doornkraal Vlaktes (Edms.) Bpk., in vrywillige likwidasie. 14/5/84. Dividend word uitgekeer. I. B. Roets, Posbus 9, Welkom, 9460.
 T222/79—Specon Construction (Pty) Ltd, 1/11/83. Preferent award. S. Trakman, P.O. Box 62016, Marshalltown, 2107.
 T1687/83—Rhino Mansions (Pty) Ltd, members' voluntary winding-up. 17/5/84. Dividend being paid. Alex Kier, P.O. Box 5511, Johannesburg.
 T1548/72—Shaw, W. A. 8/5/83. Dividends being paid. C. G. Foot, c/o Syfrets Trustees, P.O. Box 61058, Marshalltown, 2107.
 T1504/82—Light 'n Braai (Pty) Ltd, in liquidation. 11/4/84. Dividends to secured creditors only. D. M. Meaker, c/o Syfrets Trustees (Tvl), P.O. Box 61058, Marshalltown, 2107.
 T734/82—Quiterio, L. da Silra. 10/5/84. Dividends being paid. C. R. G. Fisher, Trustee, c/o Syfrets Trust, P.O. Box 61058, Marshalltown, 2107.
 T587/81—Al Conco (Pty) Ltd, in liquidation. 17/5/84. Dividend to creditors. Neil Bowman, P.O. Box 10527, Johannesburg.
 T973/78—Stefcol Holdings (Pty) Ltd, in liquidation. 8/5/84. Secured award only. Neil Bowman, P.O. Box 10527, Johannesburg.
 T1142/81—Jageco Construction (Pty) Ltd, in liquidation. 9 May 1984. Dividends. B. T. Whitson, c/o Syfrets Trust Ltd, P.O. Box 1830, Pretoria, 0001.
 T1499/81—Dwayneamac (Pty) Ltd, in liquidation. 16 May 1984. Dividends. B. T. Whitson, P.O. Box 1830, Pretoria, 0001.
 T1188/82—Springbok Flats Garage (Pty) Ltd, in liquidation. 21 May 1984. Dividend. R. B. Prosch, P.O. Box 1830, Pretoria, 0001.
 C419/82/5B—Pan Properties Ltd, 7 May 1984. Dividend paid. I. Jowell, P.O. Box 3147, Cape Town, 8000.
 13992/81—Proctor, Beryl Pamela Gertrude. 9/5/84. Secured, Preferent and concurrent dividends are being paid. Louisa Elizabeth van der Grijp, as nominee of Nedbank Ltd, c/o Syfrets Trust Ltd, P.O. Box 61058, Marshalltown, 2107.
 T128/82—Lochner, A. 24/5/84. Contribution is being levied. P. A. Cronje, c/o Metboard (Pretoria) Ltd, P.O. Box 3127, Pretoria.
 T1313/78—Verligte Produkte (Pty) Ltd, in liquidation. 8 May 1984. Award to secured creditor and contribution being collected. Manfred Holzman, c/o Transvaal Board of Trustees (Pty) Ltd, P.O. Box 7062, Johannesburg, 2000.
 T934/78—Alpha Concrete (Pty) Ltd, in liquidation. 10 May 1984. Dividend being paid. Manfred Holzman, c/o Transvaal Board of Trustees (Pty) Ltd, P.O. Box 7062, Johannesburg, 2000.
 T1294/82—C & L Staalwerke. 23/5/84. Dividend betaalbaar. T. C. Muller, Posbus 1990, Pretoria.
 T1381/81/1B—Kotze, F. J. 11/5/84. Voorkeur en versekerde dividend betaalbaar. T. C. Muller, Posbus 1990, Pretoria.
 T1844/82—Ackermann, I. P. 14/5/84. Uitkeer van diwidende. F. G. Gay, Posbus 2851, Johannesburg.
 T2006/82—Kupritz, Marlene H. 15/5/84. Kontribusi te vorder. J. R. Galloway, Posbus 2851, Johannesburg.
 T1448/82—K B G R Investments (Pty) Ltd, in voluntary liquidation. 18 April 1984. Angus Crichton Campbell, P.O. Box 333, Springs, 1560.

Vorm/Form 6

AANSOEK OM REHABILITASIE

Ingevolge artikel 124 van die Insolvensiewet, 1936, word hierby kennis gegee dat die insolvente persone hieronder genoem om hul rehabilitasie aansoek sal doen op die datums, tye en plekke en om die redes wat daarin teenoor hulle onderskeie name aangedui is, met aanduiding van nommer van boedel; volle naam en beskrywing van insolvent (met inbegrip van sy geboortedatum en persoonsnommer) en plek van besigheid of woonplek; datum waarop boedel gesekwestreer is, en adres, betrekking of status van insolvent ten tye van daardie datum; afdeling van Hooggeregshof waarby en datum en tyd wanneer aansoek gedoen sal word; rede van aansoek.

APPLICATION FOR REHABILITATION

Pursuant to section 124 of the Insolvency Act, 1936, notice is hereby given that the insolvents mentioned below will apply for their rehabilitation on the dates, at the times and places and upon the grounds as therein set forth opposite their respective names, indicating number of estate; full name and description of insolvent (including his date of birth and identity number) and place of business or residence; date when estate sequestrated, and address, occupation or status of insolvent at the time of that date; division of Supreme Court to which and date and time on which application will be made; ground of application.

- T532/79—**Souris**, Tehdor, 29/3/40, 4003295036008, engineer at Besaans du Plessis, 275 Stevenson Road, Pretoria West. 8 May 1979, 291 Kenene Avenue, Sinoville, Pretoria. Transvaal Provincial, 24 July 1984, 10h00. In terms of section 124 (2) (a) of the Insolvency Act, No. 24 of 1936, as amended.
- B170/82—**Henderson**, Hendrik Johannes, 540302504000, woonadres: Ridderstraat 3, Fleurdal, Bloemfontein. 26 Augustus 1982, verteenwoordiger van Multifloor Fleur la Grande, Meenthuis 19, Fleurdal, Bloemfontein, O.V.S. met woonadres te Fleur de Grande, Meenthuis 19, Fleurdal, Bloemfontein, O.V.S. Oranje-Vrystaatse Provinsiale, 5 Julie 1984, 10 vm. Artikel 124 (5) alle skuldeisers betaal.
- B169/82—**Viljoen**, Francois Petrus, 5311235097009, verteenwoordiger van S.A. Mutual Assuransie Maatskappy, met woonplek te Zondereindstraat 108, Harmony, Virginia, O.V.S. 26 Augustus 1982, werksadres: Decor Flooring, Ouderlingstraat 4, Virginia, O.V.S., woonadres: Wilmarhof 3, Virginiaweg, Virginia, O.V.S. Oranje-Vrystaatse Provinsiale, 5 Julie 1984, 10 vm. Artikel 124 (5) alle skuldeisers betaal.
- T418/75—**Cooper**, Robert Mullan, 15 October 1930, 3010155001007, sales representative employed by Greatrex (Pty) Ltd, 10 Livingstone Road, Pinetown, Natal. 30 April 1975, builder of 3 Glen Street, Kenmore, Krugersdorp. Transvaal Provincial, 24 July 1984, 10h00. In terms of section 124 (2) (a) of the Insolvency Act, No. 24 of 1936, a period of four years having elapsed from date of sequestration and a period of one year having elapsed from date of confirmation of account.
- C337/79—**Zurnamer**, David Neal, 21 Januarie 1943, 4301215012004, Caledonstraat 28, George. 29 Augustus 1979, Sandweg 17, Wildernis. Kaap die Goeie Hoop Provinsiale, 2 Augustus 1984, 10h30. Artikel 124 (2) (b).
- T1045/77—**Leeferink**, Robert, 7 October 1937, builder, residential address: Rigolettohof 10, 2502 Ex Alphen A/D Rijn Holland. 21 June 1977, Final Order. 6 September 1977, 300 Daylisford Avenue, Mondeor, Johannesburg, builder trading as R. Leeferink & Sons. Witwatersrand Local, 24 July 1984, 10h00. Section 124 (2) (a) of the Insolvency Act, No. 24 of 1936.
- T95/76—**Fouche**, Stephanus Phillipus, 11/5/27, 2705115036008, konstruksie voorman, Wichtstraat 37, Brits. 20 Januarie 1976, Riefonteinweg 6a, Boksburg, laaiblad bestuurder. Transvaalse Provinsiale, 31 Julie 1984, 10.00 vm. Artikel 124 (2) (a) van die Insolvensie Wet, No. 24 van 1936, soos gewysig.
- I653/77—**Rost**, Fritz Karb, 20/7/36, 3607205003006, skilder te Komati Kragstasie, Middelburg, Tvl. 29 November 1977, skilder, Vaalbank Plote. Transvaalse Provinsiale, 24 Julie 1984, 10h00. Artikel 124 (2) (a) Wet 24 van 1936.
- T290/80—**De Jager**, Johan Diederick Ungerer, 21/7/30, 3007215019003, eiendomsagent. 1 April 1980, handelaar in hardeware, J. D. U. de Jager (Edms.) Bpk., Middelburg, Tvl. Transvaalse Provinsiale, 31/7/84, 10 vm. Artikel 124 (2) (b) Wet 24 van 1936.
- T299/79—**Viljoen**, Marius, 7 November 1947, 4711075166007, Plot 188, Highbury, Meyerton, Tvl. 13 Maart 1979, Welgelegen, distrik Potgietersrus. Transvaalse Provinsiale, 24 Julie 1984, 10h00. Kragtens artikel 124 (2) (a) van die Insolvensiewet, 1936.
- T399/79—**Jones**, Michael John David, 16 May 1936, 3605165036107, financial adviser, 40 Upper Hill Street, Port Elizabeth. 3/4/79, chicken farmer, Plot 95, Vastfontein, Pretoria. Transvaal Provincial, 31/7/84, 10 a.m. Section 124 (2) (a).
- E5/80—**Du Preez**, Hendrik Petrus Theodorus Lambertus, 11/8/45, 4508115119008, Assistant Director of Finance, East Cape Development Board. 17/1/80, 48 Tafelsberg Road, Queenstown, East Cape Administration Board. Eastern Cape, 26/7/84, 10.00 a.m. In terms of Section 124 (2) (a) of Insolvency Act No. 24 of 1936, as amended.
- C566/78—**Petersen**, Sidney Joseph, 5 May 1934, 3405055006017, practising attorney, Notary Public and Conveyancer, Petersen Centre, corner of Klipfontein and Lawrence Roads, Athlone, 40 Athlone Street, Athlone Cape. 29 August 1978, final 29 November 1978, resided at 61 First Avenue, Fairways, Wynberg, Cape and practised as an attorney, Notary Public and Conveyancer, at Petersen Centre, corner of Klipfontein and Lawrence Roads, Athlone, Cape. Cape of Good Hope Provincial, 25 July 1984, 10h30. In terms of section 124 (2) (a) of the Insolvency Act, 1936, as amended.
- C92/79—**Van Niekirk**, Charl Malan, 16 April 1923, 2304165013008, Hoofweg, Joubertina, Kaap en werksaam te Laerskool Krakeelrivier, distrik Joubertina, onderwyser. 21 Maart 1979, Hoofweg, Joubertina, Kaap, deelydse boer te Hoofweg, Joubertina, Kaap, onderwyser te Laerskool Krakeelrivier, distrik Joubertina. Kaap die Goeie Hoop Provinsiale, 25 Julie 1984, 10h30. Artikel 124 (2) (b) van Wet 24 van 1936, soos gewysig.

Vorm/Form 7

KENNISGEWING VAN KURATORS

Aangesien 'n tydperk van ses maande verloop het sedert die bekragtiging van die finale kuratorsrekenings in die boedels hieronder genoem, word hierby kennis gegee dat die kurators van genoemde boedels ingevolge artikel 155 van die Insolvensiewet, 1936, alle boeke en stukke in hulre besit wat betrekking op daardie boedels het (behalwe die wat by die Meesters ingedien moet word), ses weke na die datum hiervan sal vernietig.

Die besonderhede word verstrekk in die volgorde: Nommer van boedel; naam en beskrywing van boedel; datum van sekwestrasiebevel; afdeling van Hooggeregshof waardeur bevel gegee is; datum van bekragtiging van finale rekening, en naam en adres van kurator.

NOTICE OF TRUSTEES

Notice is hereby given that a period of six months having elapsed since the confirmation of the final trustees' accounts in the estates mentioned below, the trustees of the said estates will, pursuant to section 155 of the Insolvency Act, 1936, destroy all the books and documents in their possession relating to the said estates (except those which are required to be lodged with the Masters) after six weeks from the date of this notice.

The particulars are given in the following order: Number of estate; name and description of estate; date of sequestration order; division of the Supreme Court by which order made; date of confirmation of final account, and name and address of curator.

T1330/75—**Investments Unknown (Pty) Ltd.** 27/7/76, Witwatersrand Local. May 1978. C. R. Lansdown & M. I. Cato, c/o Syfrets Trustees Ltd, P.O. Box 61058, Marshalltown, 2107.

T1826/76—**Crescendo Enterprises (Pty) Ltd.** 7/12/77, Witwatersrand Local. 16/3/78. C. R. Lansdown, c/o Syfrets Trustees Ltd, P.O. Box 61058, Marshalltown, 2107.

- T1574/75—Ausch Landgoed (Edms.) Bpk. 9/12/75, Witwatersrand Local. 7/11/78. C. G. Foot & A. Hessels, c/o Syfrets Trustees Ltd, P.O Box 61058, Marshalltown, 2107.
- T1527/76—Northmost Building Supplies (Pty) Ltd. 19/10/76, Witwatersrand Local. 6/11/78. C. R. Lansdown, c/o Syfrets Trustees Ltd, P.O Box 61058, Marshalltown, 2107.
- T524/77—Internac. 15/3/77, Witwatersrand Local. 26/9/78. G. B. Christie, c/o Syfrets Trustees Ltd, P.O Box 61058, Marshalltown, 2107.
- T853/77—Uncle Willy's 1964 (Pty) Ltd. 10/5/77, Witwatersrand Local. 21/2/78. G. B. Christie, c/o Syfrets Trustees Ltd, P.O Box 61058, Marshalltown, 2107.
- T785/78—De Villiers, Rocco. 2/5/78, Witwatersrand Local. 27/6/83. C. R. Lansdown, c/o Syfrets Trustees Ltd, P.O Box 61058, Marshalltown, 2107.
- T1025/80—De Klerk, W. P. 9/9/80, Witwatersrand Local. 28/6/83. C. R. G. Fisher, c/o Syfrets Trustees Ltd, P.O Box 61058, Marshalltown, 2107.
- T1035/81—Watts, R. A. 25/8/81, Witwatersrand Local. 18/3/83. C. R. G. Fisher, c/o Syfrets Trustees Ltd, P.O Box 61058, Marshalltown, 2107.
- T776—Adeo (Pty) Ltd. 30/12/75, Witwatersrand Local. 20/4/78. Brian Terence Whitson, c/o Syfrets Trustees Ltd, P.O Box 61058, Marshalltown, 2107.
- N406/82—Favish, Walter. 26 October 1982, Durban and Coast Local. 15 November 1983. A. G. O'Connell, c/o The Board of Executors Natal Ltd, P.O. Box 4743, Durban, 4000.
- N361/82—Ebrahim, Faizal, who traded as Ebrahim Sports. 5 October 1982, Durban and Coast Local. 20/10/83. John Allan Bruce, c/o Metboard (Natal) Ltd, P.O. Box 3912, Durban, 4000.
- N121/77—Roux, Willem Barend Gerhardus. 4 March 1977, Durban and Coast Local. 20/10/83. John Allan Bruce, c/o Metboard (Natal) Ltd, P.O. Box 3912, Durban.

Vorm/Form 8

DATUMS VASGESTEL VIR DIE BEWYS VAN EISE DEUR SKULDEISERS

Ingevolge artikel 179 (2) van die Maatskappywet, 1926, artikel 366 (2) van die Maatskappywet, 1973, word hierby kennis gegee van die datums of termyne deur Meesters van die Hooggeregshof vasgestel tot wanneer skuldeisers van maatskappye in likwidasie hulle eise moet bewys of anders van die voordeel van 'n distribusie kragtens 'n rekening by die Meester ingedien voordat daardie eis bewys is, uitgesluit word.

Die besonderhede word verstrekk in die volgorde: Nommer van maatskappy in likwidasie; naam en beskrywing van maatskappy; datum of termyn deur Meester vasgestel; naam en adres van likwidateur.

DATES FIXED FOR CREDITORS TO PROVE CLAIMS

Pursuant to section 179 (2) of the Companies Act, 1926, section 366 (2) of the Companies Act, 1973, notice is hereby given of the dates or times fixed by Masters of the Supreme Court by which creditors of companies in liquidation are to prove their claims or otherwise be excluded from the benefit of any distribution under any account lodged with the Master before those debts are proved.

The particulars are given in the following order: Number of company in liquidation; name and description of company; date or time fixed by the Master; name and address of liquidator.

- B276/83—Landkrag Slaghuys (Edms.) Bpk., handeldrywende as Boshof Slaghuys, in likwidasie. 20 Junie 1984. F. B. Pretorius, p/a E. G. Cooper & Seuns, Cooper House, St Andrewstraat 157, Posbus 27, Bloemfontein.

Vorm/Form 9

KENNISGEWINGS VAN OORGAWA VAN 'N SKULDENAAR SE BOEDEL

Ingevolge artikel 4 (1) van die Insolvensiewet, No. 24 van 1936, soos gewysig, word hierby deur 'n versoeker kennis gegee van sy aansoek wat by die Hooggeregshof op die dag en tyd soos genoem gedoen sal word, of so spoedig daarna as wat die saak verhoor kan word, om aanname van die oorgawe van sy boedel; of van die intrekking van 'n sodanige vroeëre kennisgewing van oorgawe en na verkryging van die Meester se toestemming, ingevolge artikel 7 van die Wet.

Die inligting word, waar van toepassing, verstrekk in die volgorde: (1) Naam van aansoeker, beroep en adres, styl van vennootskap of firma, en name en adresse van vennote; (2) of 'n aansoek, die Afdeling van die Hooggeregshof en datum en tyd van aansoek, of intrekking van 'n kennisgewing van oorgawe en datum van Meester se toestemming; (3) datum vanaf wanneer sy vermoëstaat ter insae sal lê vir 14 dae, die Meester se kantoor en, indien so, die Landdros se kantoor waar dit sal lê; (4) die prokureur van die aansoeker, adres en datum.

NOTICES OF SURRENDER OF A DEBTOR'S ESTATE

In terms of section 4 (1) of the Insolvency Act, No. 24 of 1936, as amended, notice is hereby given by a petitioner of his making an application to the Supreme Court on the date and time as stated or as soon thereafter as the matter can be heard, for the acceptance of the surrender of his estate; or of the withdrawal of such notice of surrender previously made and upon having received the Master's consent, in terms of section 7 of the Act.

The information, where applicable, is given in the following order: (1) Name of petitioner, occupation and address, style of partnership or firm, and names and addresses of partners; (2) whether application, Division of Supreme Court and date and time of application, or withdrawal of notice of surrender and date of Master's consent; (3) date as from which a statement of his affairs will lie for inspection for 14 days, the Master's Office where lying and, if so, the Magistrate's Office; (4) attorney for petitioner, address and date.

- Van Nieuwenhuizen, Nicolaas Stephanus, Manibawoonstelle 214, 12de Laan, Gezina, Pretoria. (2) Aansoek, Transvaalse Provinsiale. 10 Julie 1984. (3) 11 Junie 1984. (4) Borchardt & Hansen, Applikant se Prokureur, Derde Verdieping, Pieter Neethlinggebou, Sentraalstraat, Pretoria.
- Levy, Makkie, a builder of 46 Lady May Street, Athlone. (2) Application, Cape Provincial, 3 July 1984, 10.30 o'clock in the forenoon. (3) 11 June 1984, Wynberg. (4) M. R. Khan & Associates, Attorney for Debtor, 45 Belgravia Road, Athlone.
- Moster, Hendrik Johannes, wie besigheid gedoen het onder die naam Seasprite Pools, van Humanstraat 14, Despatch. (2) Aansoek, Suid-Oos Kaapse Plaaslike, 3 Julie 1984, 10h00. (3) 11 Junie 1984, Grahamstad, Port Elizabeth en Uitenhage. (4) Fourie Van Rensburg & Kitshof, Eerste Verdieping, Emekhuis, Markstraat, Noordeinde, Port Elizabeth.

VERLORE LEWENSVERSEKERINGSPOLISSE LOST LIFE INSURANCE POLICIES

Vorm/Form VL

Artikel 64, Wet 27 van 1943

Kennisgewing geskied hiermee dat bewys van die verlies of vernietiging van die polisse hieronder vermeld, aan die versekeraars gelewer is, en enigeen wat in besit van enige van hierdie polisse is, of aanspraak maak dat hy enige belang daarin het, moet onmiddellik per aangetekende pos met die versekeraars in verbinding tree. By gebreke aan sodanige mededeling sal gewaarmerkte afskrifte van polisse (wat die enigste bewys van die kontrak sal wees) aan die eienaars uitgereik word ingevolge die regulasies gepromulgeer onder die Wet.

Die besonderhede word verstrekk in die volgende: Naam en adres van versekeraar; polissonummer, datum van polis en versekerde bedrag; lewe verseker; eienaar, indien ander as versekerde.

Section 64, Act 27 of 1943

Notice is hereby given that evidence of the loss or destruction of the policies mentioned below, has been submitted to the insurers, and any person in possession of any of these policies, or claiming to have any interest therein, should communicate immediately by registered post with the insurers. Failing any such communication, certified copies of the policies (which shall be the sole evidence of the contract) will be issued to the owners in terms of the regulations framed under the Act.

The particulars are given in the following order: Name and address of insurer; policy number, date of policy, and sum insured; life insured; owner, if other than insured.

Atlantiese en Continentale Assurance Maatskappy van Suid-Afrika Bpk., Posbus 5813, Johannesburg, 2000

511016—1/12/51, R500. Agneta Nyusela.
 050297—1/2/65, R1 000. David Duke Sebolai.
 701476—1/5/70, R500. Samuel Smile.
 708542—1/3/70, R800. Kwenene Mtambeka.
 735219—1/11/73, R1 500. Dinah Pharo Williams.
 756664—1/12/75, R1 500. Michael Manoko Manaka.
 7603105—1/6/76, R2 000. Reuben Spanik Mosathupa.
 7702204—1/4/77, R2 000. Martha Margaretha Vorster.
 7703806—1/7/77, R2 500. Jan Hendrik Swanepoel.
 7902359—1/6/79, R2 000. Agrippa Nbuyiseli Mbebe.
 7903228—1/7/79, R3 300. Gert Johannes Jacobus J. van As.
 7903956—1/9/79, R1 500. David Themba Ndaba.
 7905665—1/12/79, R1 730. Sechanotho Christian Mogale.
 8003529—1/6/80, R2 000. Maerman Kokolani Mnguni.
 8003583—1/6/80, R1 400. Mabotsana Dirty Tieane.
 8004148—1/6/80, R11 578. Louis Daniel Kotze.
 8005033—1/7/80, R1 363. Fanie Jack.
 8006167—1/9/80, R1 000. Nkwatini Alfred Dube.
 8006783—1/10/80, R1 428. Samson Nzafani Kumalo.
 8100739—1/2/81, R1 000. Tambo Mackson Mkhetho.
 8102001—1/3/81, R3 478. Jonas Mmuso Maseloa.
 8102049—1/3/81, R3 879. Johannes Wilhelmus Rossouw.
 8102191—1/4/81, R4 565. David Kgofantsoa Marumolao.
 8102964—1/5/81, R2 000. Isaac Mabelane.
 8103597—1/5/81, R1 216. Matthews Mate.
 8104716—1/6/81, R2 000. Mathaka Piet Mosweu.
 8107967—1/10/81, R1 197. Maerman Mnguni.
 8200876—1/1/82, R2 142. Mawbray Jacobs.
 8203348—1/2/82, R2 756. Albert Lebobo.
 8308317—1/8/83, R2 000. Tembisa Meleni.

Allianz Lewens Bpk., Posbus 1652, Johannesburg, 2000

24003506—1 Julie 1972, R10 027. Cornelios Francios Vermeulen.
 21000675—1 Julie 1971, R50 000. Alfred Promnick.
 21001299—1 Oktober 1971, R4 600. Cornelios Francios Vermeulen.

Guardian National Ins. Co. Ltd, P.O. Box 3329, Johannesburg, 2000

110675—1/4/61, R2 000. W. Sam Hing.
 200839—1/8/73, R1 500. C. Nagamah (Pillay).
 314317—1/4/83, R35 000. F. & G. Marty.

Legal & General Volkskas Assurance Ltd, P.O. Box 4870, Johannesburg, 2000

UL6299432—1/2/82, R17 690. Edward Claude Butler.
 AF3760683—1/5/65, R4 000. George von Backstrom.
 UL5238886—1/1/78, R9 051. Hendrik Gerhardus Badenhorst.
 AF3048634—1/6/56, R2 000. Lourens Erasmus Botha.
 AF3857885—1/7/66, R1 074. Beverly Gay Arnot Bowden.
 UL5458740—1/7/79, R7 219. Johan Frederik Coetzee.
 AF4529004—1/1/75, R9 000. Frances Anthea Hardman.

AF3911203—1/5/67, R1 128. Hedley Edward Joubert.
 AF3990848—1/6/68, R1 542. Ivan Kruger.
 AF3911914—1/5/67, R1 128. Ivan Kruger.
 AF4412532—1/11/75, R1 500. Christinah Dolly Kaynie.
 AF1102508—1/8/74, R33 000. Henry Isaac Kahn.
 UL6113039—1/11/81, R20 000. Louise Theresa Deanna Lefevre.
 UL5140173—1/5/77, R4 137. Robert McMurray.
 UL5110325—1/3/77, R9 026. Petrus Marthinus Oberholzer.
 AF0470443—1/7/52, R2 000. Raymond Peyper.
 UL5871561—1/2/81, R10 008. Raymond Pieterse.
 UL6718316—1/6/83, R60 000. Johannes Andries Steyn.
 AF0889188—1/12/65, R4 000. David Bernard Solovei.
 AF3839362—1/5/66, R5 000. David Bernard Solovei.
 AF4129615—1/7/70, R8 000. David Bernard Solovei.
 AF4468682—1/7/74, R8 264. David Bernard Solovei.
 UL5697305—1/8/80, R60 000. Lloyd Henry Smith.
 UL5801709—1/11/80, R8 975. Leon Viviers.
 AF4630950—1/7/76, R7 000. Guillaum Johannes Wild.
 AF1164565—1/11/75, R5 000. William Henry Henning.

Miss S. Hardam, Liberty Life

3756429—13/3/70, R10 000. M. Ramsamy.
 9133608—1/8/79, R10 965. L. A. du Preez.
 9352356—1/12/83, R39 000. L. E. Brown; Liberty Life Association of Africa Ltd.
 9093429—1/9/77, R12 000. G. D. Padayachee.
 7000027—26/1/73, R10 000. C. J. van der Merwe.
 4676855—17/3/67, R4 078. D. P. Riall.
 9229353—1/6/81, R13 401. G. Rajah.
 0732086—1/3/74, R7 295. Late I. C. Gibson.
 0732085—1/3/74, R14 590. Late I. C. Gibson.
 9094394—1/7/77, R17 245. W. F. Frisby; C. J. Frisby.
 9048468—1/11/75, R11 734. W. W. Kambeck.
 9143410—1/7/79, R3 530. P. J. Meyer.
 1270984—20/11/53, R6 400. R. A. Jacobson.
 7005210—7/9/73, R6 480. A. H. Phillips.
 9116007—1/5/78, R5 148. D. T. Gallinetti.
 1058587—17/9/48, R6 000. Late W. H. Alexander; C. E. W. Alexander.
 9028032—1/9/75, R16 216. Late J. C. H. Lamb.
 3762040—1/10/70, R20 000. A. R. Leca.
 2110351—23/1/70, R4 000. W. J. Powell.
 9089328—1/8/77, R29 357. J. A. Denyssen.
 5019544/600—1/3/84, R200 000. D. B. Brunette.
 3343719—27/6/42, R1 000. Late G. Ziman.
 3342528—27/6/42, R2 000. Late G. Ziman.
 3594491—23/11/56, R6 000. Late G. Ziman.
 9109429—1/3/78, R20 000. L. Segal.

Ou Mutual, Posbus 66, Kaapstad, 8000

4330774—14/11/83, R61 325. J. C. Starke.
 3320785—16/11/78, R3 167. A. Williamson.
 2372700—5/5/71, R950. A. G. Nogomba.
 2102978—5/9/67, R489,21. O. P. van Rensburg; S. J. L. van Rensburg.
 1976378—1/9/65, R2 000. J. D. Martin; M. Martin.
 2971392—16/4/76, R2 219. C. A. Welman.
 3305616—9/10/78, R3 461. C. A. Welman.
 3942743—29/3/82, R12 731. A. Z. Ncwane.
 4274801—26/9/83, R7 470. S. Guzana.
 1990996—29/11/65, R3 593. R. F. Steele.
 4360939—27/12/83, R6 031. G. J. Mavunda; M. H. Mavunda.
 1520911—18/8/59, R2 120. M. H. Hurwitz and Nedfin Bank.
 3548521—29/4/80, R10 504. J. J. Ntshangase.
 4097617—11/11/82, R5 527. L. Ackerman.
 3905177—11/1/82, R7 299. A. H. Fischer.
 3501819—27/12/79, R10 001. L. van der Walt; H. Fouche.
 3510851—28/1/80, R16 666. H. Fouche.
 3663512—8/11/80, R10 000. A. S. van der Walt; H. Fouche.
 3665691—13/11/80, R6 421. H. Fouche.
 2014413—2/5/66, R3 000. W. P. Joubert.
 2544112—24/1/73, R1 213. P. G. Walsh.
 2875949—1/8/75, R3 713. P. G. Walsh.
 2940912—2/2/76, R1 000. N. Walsh; P. G. Walsh.
 3305013—27/10/78, R1 149. T. Walsh; P. G. Walsh.
 3312808—28/10/78, R4 047. P. G. Walsh.
 2633936—28/8/73, R1 385. J. E. Mashigo; estate late/boedel wyle R. Mashigo.
 2636246—6/9/73, R1 145. H. M. Mashigo; estate late/boedel wyle R. Mashigo.
 4056028—28/8/82, R7 844. M. F. Marageni.
 3459947—2/10/79, R20 000. A. Erasmus.
 3311841—26/10/78, R3 559. L. R. de Beer; A. L. de Beer.
 4166611—19/3/83, R17 535. S. S. Ngcobo.
 4161346—12/3/83, R5 840. G. C. Vermeulen.

- 3887860—10/12/81, R3 905. I. Kakuuai.
 3722451—20/3/81, R4 021. N. N. Malgas; T. A. M. Malgas.
 1939319—26/2/65, R4 000. C. P. F. Marais Jr; estate late/boedel wyle C. P. F. Marais Sr.
 4342649—17/12/83, R9 081. K. A. Bawden.
 4341972—12/12/83, R18 026. S. Elder.
 4332637—17/11/83, R9 805. F. E. Hufkie.
 3884613—23/11/81, R6 375. T. R. Mnyameni.
 4142739—12/2/83, R4 198. D. Paiva.
 4249320—7/7/83, R6 665. N. Mabandla.
 4272156—26/8/83, R2 331. A. de Vos.
 3316955—6/11/78, R8 900. A. Faul and Trust Bank.
 3010795—16/8/76, R7 260. C. E. Janse van Rensburg.
 4374462—27/1/84, R9 428. M. Z. Hlatshwayo.
 4351146—4/2/84, R6 300. B. I. Ntuli.
 3879730—13/11/81, R6 371. P. T. Tofile.
 1432309—4/9/58, R659. J. M. F. Cornelius.
 3861850—8/10/81, R7 574. S. M. Nkalitshana.
 3615793—20/8/80, R110 000. T. C. P. Johnstone; J. T. Johnstone.
 4353946—15/12/83, R4 704. I. P. Deysel.
 3741410—27/4/81, R10 000. A. Gray.
 4171840—26/3/83, R4 870. J. Klaasens.
 3365998—16/3/79, R5 125. M. S. Eloff.
 3555633—3/5/80, R4 285. J. J. Prinsloo.
 3975845—7/6/82, R20 007. P. H. Phoofolo.
 3844945—20/6/81, R4 326. P. B. Madikizela.
 3801329—24/8/81, R4 018. C. N. Sixaxa; A. L. Tiso.
 3695547—26/1/81, R12 602. T. P. Petros.
 2648427—11/10/73, R725. J. K. Mbiko.
 4120325—23/12/82, R6 049. J. E. Gasa.
 2837598—14/4/75, R2 240. Visvanathan.
 3163527—7/10/77, R2 000. V. Naicker.
 3896629—17/12/81, R33 467. W. A. de Bruin.
 2929140—18/12/75, R16 895. C. J. Roux.
 2895902—18/9/75, R11 872. G. D. Sparg.
 3716941—1/4/81, R6 299. D. W. Evans.
 2328862—27/10/70, R5 000. C. S. J. Bergh.
 938005—3/6/53, R2 000. J. D. Green.
 1278326—28/2/57, R2 710. J. D. Green.
 4243118—28/7/83, R17 003. C. R. Fourie.
 3830561—17/8/81, R6 342. S. B. Gobrie.
 1442995—15/10/58, R220. L. Hattingh; J. H. Hattingh.
 2179351—28/10/68, R5 000. W. A. Copeman; M. J. Copeman.
 3759507—21/5/81, R8 202. G. Govender.
 2447631—24/2/72, R1 295. B. C. du P. Grobler.
 3574653—16/6/80, R17 903. S. Atkinson.
 3666826—15/11/80, R40 039. K. Ramdhani.
 3712217—2/3/81, R31 340. K. Ramdhani.
 2476531—19/6/72, R8 978. A. J. Fourie; A. L. Fourie.
 3629153—11/7/80, R17 058. S. Terblanche.
 3294181—15/9/78, R1 356. P. J. Koetepe; M. W. Koetepe.
 3894227—12/12/81, R6 058. A. K. Daweti.
 3859901—5/10/81, R6 001. M. C. Kewuti.
 3808736—8/9/81, R6 073. V. C. Vandayar.
 3896520—17/12/81, R4 668. P. R. Modipa.
 2873977—28/7/75, R988. M. J. Arnolds.
 2280922—23/4/70, R2 000. J. H. Engelbrecht Jr.
 980678—17/12/53, R1 772. H. M. Besaans; estate late/boedel wyle H. G. L. Besaans.
 2506527—29/8/72, R1 500. E. M. E. Venter.
 4339296—25/11/83, R8 321. G. Dock.
 3802037—24/8/81, R7 535. T. G. Ngcakani.
 2976007—3/5/76, R2 664. J. N. Sopena.
 3699009—5/2/81, R4 822. F. C. Jameson.
 2250614—14/11/69, R8 668. D. H. Segall; F. Segall.
 926933—9/4/53, R4 448. H. A. van der Merwe Jr; H. A. van der Merwe Sr.
 2467416—17/5/72, R2 866. A. E. M. Botes.
 2505174—23/8/72, R4 000. A. E. M. Botes.
 3020721—30/8/76, R6 002. H. M. S. Morgan.
 4177614—8/4/83, R6 623. M. Ngcebetsha.
 3784911—20/7/81, R70 000. L. H. Fisher.
 1499501—8/6/59, R2 736. A. P. Troskie.
 3375935—6/4/79, R10 960. A. P. Troskie.
 2858439—9/6/75, R2 297. I. N. Douglas.
 4041858—20/8/82, R11 157. N. Mnyanda.
 1982163—5/10/65, R4 000. F. M. Colling; H. J. M. Butler.
 1978010—13/9/65, R3 472. G. C. J. Thirion; A. M. Thirion.
 3423543—7/8/79, R11 816. A. H. C. Julies.
 3045729—15/11/76, R10 000. A. S. Reis.
 2238731—30/9/69, R2 412. A. E. Gielink.
 2778852—14/10/74, R2 000. B. B. Monkwe.

- 3211446—27/2/78, R4 407. E. N. Ndlela.
 3141823—13/6/77, R2 508. C. Kleynhans, *née* Steur.
 3217384—10/3/78, R10 000. S. S. Masipa.
 2541350—29/1/73, R7 500. O. L. Carey.
 1794427—27/12/62, R7 000. J. J. Visagie.
 4351343—27/12/83, R15 004. M. L. Ambrosius.
 4254550—5/8/83, R40 269. B. Groenewald.
 3802214—24/8/81, R9 661. T. S. Fourie.
 3148302—24/8/77, R15 270. J. A. le R. Human.
 4320509—2/12/83, R10 576. A. M. Moloole.
 4256599—8/8/83, R10 749. D. P. Diale.
 1875858—9/3/64, R1 000. E. V. Einkamerer.
 1875859—9/3/64, R1 000. E. V. Einkamerer.
 1875860—9/3/64, R1 000. E. V. Einkamerer.
 1613275—7/9/60, R1 392. H. Wittles.
 4371060—21/1/84, R13 169. M. Zulu.
 4207479—28/5/83, R5 086. O. W. Mafuna.
 2055625—30/11/66, R1 000. L. Perumal; Seethamma.
 1833545—31/7/63, R2 000. M. J. P. Carstens.
 4313123—6/2/84, R7 620. T. M. Ngubane.
 2027933—27/6/66, R2 000. D. C. Hobson.
 2836986—11/4/75, R2 000. D. C. Hobson.
 4287445—1/10/83, R6 510. K. E. Williams and Trust Bank.
 4259405—11/8/83, R2 609. O. R. Ahrendse.
 3069052—31/1/77, R8 000. G. P. Schultz.
 2593481—5/7/73, R10 000. G. G. Mbau.
 2371784—3/5/71, R1 329. D. C. Mannel; C. J. Mannel.
 4000095—22/7/82, R5 968. A. I. G. Arendse.
 3813653—7/8/81, R8 007. L. R. Maja.
 4348803—9/12/83, R8 108. R. K. Dingaan.
 4182492—18/4/83, R21 569. A. J. Koortzen.
 3806861—3/9/81, R8 012. M. P. April.
 3753250—18/5/81, R134 544. C. G. Smit.
 3258978—23/6/78, R2 910. M. J. Lourens.
 3262426—3/7/78, R2 306. J. H. G. Lourens; M. J. Lourens.
 4338008—24/11/83, R4 184. J. G. Lotter.
 3465150—25/9/79, R15 005. W. Kristensen; Midas Printers (Pty) Ltd.
 3466210—28/9/79, R12 513. M. McGurk; Midas Printers (Pty) Ltd.
 3470099—7/10/79, R15 000. T. P. H. Sorenson; Midas Printers (Pty) Ltd.
 4341637—30/12/83, R8 975. V. Mutaleni.
 4220100—18/6/83, R9 859. T. C. Mhlongo; D. C. Mhlongo.
 3277724—14/7/78, R6 207. Q. S. Moolman.
 3220174—16/3/78, R7 554. S. N. Mocwaledi.
 2421552—11/11/71, R2 557. S. J. Buitendag and Barclays Bank.
 690999—30/6/49, R1 000. A. J. du Plessis.
 4104438—22/11/82, R3 123. S. M. Baloyi.
 3374709—9/4/79, R6 231. L. I. Court.
 2898269—25/9/75, R1 000. R. B. Meyer; B. W. Meyer.

Rand Lewensversekeringsmaatskappy Bpk., Posbus 1652, Johannesburg, 2000

60088387—1 Mei 1981, R2 000. George Mbuyiselo Mapipa.

Sanlam, Posbus 1, Sanlamhof, 7532

- 631900—1/12/55, R1 000. G. T. Vermaak.
 761258—1/7/58, R2 000. J. E. Bezuidenhout.
 1284003x9—1/9/67, R2 500. J. J. Maritz.
 1307213x7—1/7/68, R2 000. J. J. v. Z. Snyman.
 1496973x7—1/7/71, R2 000. S. F. Smit.
 1647024x7—1/11/72, R1 500. L. T. P. van der Walt; A. van der Walt.
 1718751x9—1/11/72, R1 000. A. van der Walt.
 1880882x4—1/2/74, R5 707. W. B. Faure.
 3443693x1—1/7/78, R3 500. B. J. van Deventer.
 3486891x9—1/9/78, R3 368. K. A. A. Blake.
 3733362x2—1/6/80, R5 044. K. A. A. Blake.
 3890248x2—1/3/81, R3 971. C. J. Blake.
 3508964x8—1/12/78, R5 000. A. P. Coetzer.
 3524588x5—1/1/79, R5 000. A. P. Coetzer.
 3523105x9—1/1/79, R2 268. P. S. Sethunya/M. V. Sethunya.
 3906049x6—1/5/81, R3 010. S. Leibrandt.
 7295610x5—1/5/83, R10 125. G. W. Walker.
 7502458x8—1/12/83, R5 377. G. K. Smit.
 7547549x1—1/12/83, R8 825. W. A. Schoeman.
 7611653x2—1/3/84, R16 908. H. P. Wridgway.
 1370798x9—1/9/69, R4 000. M. D. Stolfi.
 1402307x1—1/11/69, R465. J. C. Kruger.
 1564686x2—1/9/72, R2 000. S. M. A. Wessels.
 1719657x7—1/5/73, R1 000. C. H. P. Volschenk.
 1738977x6—1/2/73, R1 525. C. M. E. le Roux.
 1786873x8—29/4/74, R752. M. Smuts.

1854363x7—1/4/74, R3 000. A. J. Dreyer.
 1929294x5—1/4/75, R8 000. A. J. Dreyer.
 3667178x2—1/2/80, R2 415. A. J. Dreyer.
 1911109x5—1/4/75, R3 000. E. H. Nolte; C. R. Nolte.
 3436729x2—1/2/78, R6 210. S. P. Govender.
 3438892x6—1/2/78, R5 000. A. R. Schoeman.
 7023673x2—1/1/82, R11 425. B. S. J. Muller.
 3554066x5—1/4/79, R11 111. J. F. Botha.
 7095289x0—1/7/82, R13 000. J. Schoeman.
 7324643x1—1/1/83, R10 350. J. Schoeman.
 7417008x5—1/8/83, R9 020. A. J. de Jager.
 7465832x9—1/8/83, R13 000. M. Ferreira.
 7587841x3—1/3/84, R3 886. D. J. Herman.
 7595158x2—1/1/84, R8 877. T. G. Compaan; M. E. Compaan.
 787293—1/3/59, R2 000. D. J. van Niekerk.
 1146635x6—1/11/65, R4 000. D. J. van Niekerk.
 1361846x7—1/12/69, R1 000. H. L. Vosloo.
 1806325x5—1/2/74, R1 000. C. P. Fourie.
 1828658x3—1/2/74, R1 000. J. Z. Nondala.
 3408358x4—1/10/77, R6 810. E. M. Vorster.
 3424177x8—1/12/77, R3 416. P. G. Labuschagne.
 3565099x3—1/5/79, R2 551. H. L. M. Roets.
 3628956x9—1/8/79, R31 200. H. J. Joubert; I. Friedman.
 3651800x9—1/11/79, R31 200. I. Friedman; H. J. Joubert.
 3783979x2—1/1/81, R5 000. N. Jacobs.
 3793359x5—1/1/82, R16 326. S. A. Nkosi.
 7117427x0—1/4/82, R6 686. D. M. Grove.
 7227998x7—1/2/83, R5 248. C. R. Strachan.
 7367240x4—1/6/83, R9 948. L. Lekelakala.
 7433488x9—1/11/83, R6 572. M. A. Vermeulen.
 7484155x2—1/11/83, R51 886. S. S. Gerber.
 7521673x9—1/9/83, R14 608. E. S. du Toit.
 7558120x7—1/12/83, R185 116. J. C. Smit.
 3629536x8—1/10/79, R3 770. W. S. Hibbert.
 930372x8—1/3/62, R2 000. P. L. Oosthuizen.
 1269306x5—1/2/68, R2 000. P. L. Oosthuizen.
 763599—1/7/58, R2 000. W. J. S. Erasmus.
 964530x0—1/6/62, R6 130. J. A. S. Erasmus.
 1048696x7—1/6/64, R2 000. M. Minaar/T. C. Minaar.
 1248672x6—1/1/68, R1 000. C. J. Myburgh.
 1553116x3—1/11/71, R1 003. S. F. Strydom.
 1728773x1—1/4/73, R10 000. W. C. Pieters.
 1815908x7—1/8/74, R2 000. A. Veldtsman.
 1948457x5—1/7/75, R2 500. E. M. Greeff.
 3360948x8—1/5/77, R6 970. F. M. Gonsalves.
 3366828x6—1/7/77, R7 300. J. S. Pretorius.
 3705775x9—1/5/80, R6 210. H. E. Porter.
 3747129x9—1/7/80, R7 372. J. S. Grove.
 3887271x9—1/8/81, R2 738. M. Simons.
 3995207x2—1/1/82, R3 539. M. M. Kotze.
 7062240x2—1/3/82, R45 581. J. E. Swart; Vangro South African (Pty) Ltd.
 7122639x3—1/9/82, R15 560. J. J. Carolus.
 7243715x5—1/7/82, R3 208. A. M. Swanepoel.
 7277205x6—1/8/82, R7 590. R. E. Jones.
 7085196x9—1/4/82, R16 051. S. A. Botha.
 1051777x9—1/6/64, R2 000. M. H. Diedericks.
 1228397x4—1/9/66, R4 000. P. L. Viviers.
 1357590x7—1/8/69, R1 500. B. A. de Kock.
 2980109x9—1/10/79, R1 874. T. H. v. d. Merwe.
 1914409x6—1/7/74, R2 000. J. F. Louw.
 3336489x4—1/3/77, R2 000. B. Davis.
 3346870x3—1/8/77, R3 420. A. S. Hattingh.
 3415829x5—1/7/77, R7 330. A. L. Pretorius.
 3628903x1—1/7/79, R6 680. A. M. Whitehead; Dalling & Co.
 3634886x0—1/11/79, R11 000. A. N. de Klerk.
 3733135x2—1/6/80, R16 280. J. J. Schimper.
 3857273x1—1/4/81, R9 228. W. J. J. Landman.
 3979603x2—1/9/81, R5 130. C. P. Craythorne.
 7225109x3—1/3/83, R6 278. A. R. Harman.
 7308899x9—1/1/83, R16 451. J. Bezuidenhout.
 7428186x6—1/9/83, R8 686. A. Needham.
 7478727x6—1/11/83, R19 053. M. Steyn.
 7504007x1—1/1/84, R18 300. P. I. Labuschagne.
 7565202x4—1/12/83, R10 950. M. J. S. Venter.
 7595347x1—1/4/84, R6 000. L. J. Swart.
 1829166x6—1/1/74, R8 822. N. A. Smith.
 3429837x2—1/1/78, R3 212. J. S. Genis.
 1881604x1—1/6/74, R1 231. I. H. de Jager.
 1574503x7—1/10/71, R4 000. C. L. de Wet.
 1723624x1—1/11/72, R2 100. D. E. W. Visser.

1786147x7—1/3/74, R6 676. A. T. Coetzee.
 3480515x0—1/12/78, R3 320. W. M. Morris.
 3512421x3—1/12/78, R6 810. C. J. Lessingh.
 3687839x5—1/4/80, R10 000. H. G. Froneman.
 3781957x0—1/10/80, R6 624. J. A. de Villiers.
 3816957x9—1/2/81, R31 300. H. L. Diedericks; J. H. Diedericks.
 3934437x9—1/8/81, R5 278. C. J. Pietersen.
 7056669x0—1/3/82, R5 820. H. E. Gouws.
 7011748x6—1/2/82, R25 748. L. Theron.
 7221662x5—1/4/84, R29 261. S. R. Lang.
 7223814x0—1/7/82, R10 740. T. J. P. Kruger; Gemeente van Christus.
 7291765x1—1/1/83, R5 777. J. M. Williams.
 7360712x9—1/1/83, R13 227. A. A. C. Fraser.
 7437974x4—1/12/83, R16 355. P. D. van Vuuren.
 7517402x9—1/10/83, R11 097. H. F. Botha.
 3905773x2—1/4/81, R2 920. A. Isaacs.
 1746479x3—1/7/73, R1 645. W. A. Kriege; J. I. Kemp.
 1940520x8—1/5/75, R2 570. H. J. A. Kruger.
 3257939x3—1/11/77, R6 000. H. Vorster.
 3327805x2—1/3/77, R1 000. M. J. du Plessis; A. J. F. du Plessis.
 3545538x5—1/4/79, R5 886. F. W. Stander.
 3584937x1—1/9/79, R6 517. Y. Oosthuizen.
 3646391x7—1/12/79, R1 885. C. J. Cilliers.
 3658834x1—1/12/79, R2 779. M. Kahuhuena.
 3746924x4—1/7/80, R4 504. L. L. du Plessis; D. du Plessis.
 3827717x4—1/1/81, R6 861. S. J. Marshall.
 3848474x7—1/5/81, R7 602. G. P. Niewoudt.
 3887380x8—1/6/81, R6 405. B. W. Strydom.
 7090895x9—1/4/82, R2 366. E. Thindisa.
 7106011x5—1/4/82, R4 123. T. D. Seema.
 7152013x4—1/6/82, R7 500. M. I. Grobler.
 7287960x4—1/12/82, R5 047. J. Coetser.
 7392552x1—1/5/83, R7 317. J. P. Molefe.
 7437771x4—1/11/83, R6 640. L. Barkhuizen.
 7548464x2—1/1/84, R6 469. P. N. Fouche.
 7553568x2—1/2/84, R48 600. B. P. du Plessis.
 1183862x0—1/8/66, R3 858. E. D. Theron; L. P. Theron.
 1562910x8—1/10/71, R1 500. M. M. van Jaarsveld.
 1669997x7—1/6/72, R2 580. J. D. Aucamp.
 1622965x0—1/3/72, R2 000. A. S. E. Graaff.
 1959446x4—1/4/75, R2 934. J. D. Burger.
 1976220x2—1/7/75, R3 000. T. Els.
 2993639x0—1/10/79, R3 840. C. W. Heydenrych.
 3320364x7—1/7/76, R3 000. A. J. Agenbag.
 3540322x9—1/7/79, R1 401. C. du Plessis.
 3572602x5—1/4/79, R3 500. M. J. du Preez.
 3702586x3—1/6/80, R3 520. A. J. A. Swanepoel.
 3743058x4—1/8/80, R8 000. R. B. Blakeney.
 3757311x0—1/9/80, R6 210. G. M. van Niekerk.
 3828267x9—1/5/81, R9 548. A. D. de Waal.
 7088456x4—1/11/81, R31 058. J. C. Vorster.
 7112027x3—1/3/82, R2 846. C. C. Swart.
 7189603x9—1/6/82, R7 731. S. J. Coetzee.
 7433952x4—1/1/84, R8 137. M. Venter.
 7571936x9—1/11/83, R7 027. S. A. Priestman.
 3384445x7—1/5/77, R4 000. S. Bouwer.
 632736—1/1/56, R2 000. H. Steyn en J. C. Steyn.
 1817098x5—1/11/74, R5 000. G. J. Fourie.
 425553—1/6/50, R640. J. A. Steenkamp.
 775874—1/11/58, R2 000. M. S. Rae.
 1054260x3—1/7/64, R500. H. A. Blom.
 1194406x3—1/6/66, R2 195. H. Joubert.
 1528570x3—1/8/71, R1 034. O. S. Selaolane.
 1594694x0—1/7/72, R1 000. A. R. Lee.
 1619712x1—1/12/72, R11 232. R. W. Sutherland.
 1983555x2—1/6/76, R2 000. S. J. Niemann/A. A. Niemann.
 1984592x4—1/3/75, R1 500. C. Pretorius.
 3444628x6—1/5/78, R7 540. S. J. Pretorius.
 3623776x6—1/10/79, R3 000. A. Els.
 3789691x7—1/10/80, R10 000. S. G. Orr.
 3855954x8—1/1/81, R2 498. D. J. Smit.
 3961616x4—1/8/81, R5 120. C. P. Steyn.
 7087409x4—1/3/82, R7 981. E. Senekal.
 7168273x6—1/4/83, R7 069. T. A. Ngobese.
 7262816x7—1/9/82, R13 716. M. J. Jacobs.
 7363726x6—1/3/83, R5 812. J. Z. Nondala.
 7418588x5—1/12/83, R12 947. M. D. Doubell.
 7476852x4—1/7/83, R9 030. M. S. Rautenbach.
 1062408x8—1/4/64, R6 000. F. J. H. Buitendag.

1576730x4—1/1/72, R1 645. J. W. S. Nel.
 1834518x1—1/5/74, R619. H. M. Everson.
 1834953x0—1/2/74, R4 140. D. G. A. Horne.
 1835273x2—1/9/74, R2 000. R. Bester; R. F. Bester.
 1840472x3—1/1/74, R2 000. L. v. Z. Pieters.
 3271259x8—1/5/76, R4 500. J. J. van der Merwe.
 3356537x5—1/2/80, R13 020. A. A. van Eeden.
 3439344x7—1/7/78, R2 000. I. Carstens.
 3628814x0—1/9/79, R2 591. C. A. G. Marx.
 3638313x1—1/9/79, R2 345. N. J. du Plessis.
 3695398x2—1/6/80, R13 700. G. B. van Pletzen.
 3929518x3—1/12/81, R5 706. E. J. C. M. Fourie.
 7080819x1—1/2/82, R4 000. P. S. Venter; E. A. Venter.
 7080820x9—1/2/82, R4 000. T. I. Venter; E. A. Venter.
 7106016x4—1/5/82, R7 964. S. C. Rammala.
 3919955x9—1/5/81, R10 146. E. J. Louw.
 7195466x3—1/12/82, R16 300. A. le Roux.
 7309612x5—1/1/83, R7 357. A. J. Burger.
 7309613x3—1/1/83, R7 427. A. J. Burger.

The Prudential Assurance Company of SA Ltd, P.O. Box 1097, Johannesburg

10179359—-/6/82, R54 075. Catherina Olén.
 5241414—-/6/49, R2 000. Henry Kirsch.
 13722898—-/4/84, R1 053. Max Alfred Charles Ivins.
 10164711—-/6/81, R20 000. Roger Brett Kebble.
 10152483—-/4/80, R9 103. Retief Pretorius and Melodie Waltman.
 8103654—-/8/67, R2 000. Hendrina Margaretha Venter.
 8105957—-/3/68, R2 750. Josias Johannes Pienaar.
 6958012—-/10/64, R1 000. Isak Jacobus de Bruin.
 10152536—-/4/80, R9 372. Narendra Gokul Kooverjee.
 10148920—-/11/79, R14 980. Geoffrey Hylton Thompson.
 10169822—-/11/81, R4 228. Ildiko Vizi.
 5954553—-/12/58, R10 000. Peter Raoul Blumburg.
 5941429—-/5/57, R10 000. Peter Raoul Blumburg.
 6938724—-/12/63, R2 000. James Nigel Ravenor Pinnell by Nigel Ravenor Pinnell.

The Colonial Mutual Life Assurance Society Ltd, P.O. Box 73, Cape Town, 8000

677946—1/12/53, R500. H. L. S. Smith.
 1585697(4)—1/9/75, R7 700. B. J. Kriegler.
 4541535(3)—1/12/80, R1 500. T. Thetha.
 1575713(1)—1/9/73, R3 000. C. Isaaks.
 4531522(3)—1/8/77, R5 000. C. N. van Greunen.
 4541500(7)—1/12/80, R3 940. S. Magucane.
 1544452(4)—1/2/65, R4 000. J. W. van Aardt.
 1585599(2)—1/9/75, R10 000. L. Booth.
 370300—1/3/34, R2 000. J. W. F. Short.
 4533282(2)—1/1/78, R1 500. B. M. Gumede.
 1579924(0)—1/8/74, R30 000. J. N. Russell.
 4541133(7)—1/10/80, R13 828. R. C. Coomber.
 4538364(3)—1/12/79, R4 500. A. Bokolo.
 XA209096—1 September 1982. R51 192. Francois Gerhardus Lourens Vosloo.
 OA176402—1 June 1976, R44 310. Jozsef Dicso.

Vorm/Form MVA

DERDEPARTY-ASSURANSIE-EISE OM SKADEVERGOEDING

Wet op Verpligte Motorvoertuigversekering, 1972 (Wet 56 van 1972)

THIRD PARTY INSURANCE CLAIMS FOR COMPENSATION

Compulsory Motor Vehicle Insurance Act, 1972 (Act 56 of 1972)

KENNISGEWING DEUR BEVOEGDE VERSEKERAAR VAN OOREENKOMS BEDOEL IN ARTIKEL 26 VAN DIE WET

Die bevoegde versekeraar genoem in die Bylae hiervan, gee hierby ooreenkomstig artikel 26 (4) van die Wet kennis—

(a) dat hy 'n ooreenkoms soos in artikel 26 (3) (c) bedoel, aangegaan het om 'n bedrag te betaal ten opsigte van 'n eis om skadevergoeding ooreenkomstig artikel 21 van genoemde Wet, naamlik vergoeding wat, indien genoemde versekeraar vir die betaling daarvan aanspreeklik sou gewees het, koste ten opsigte van die akkommodasie, in 'n hospitaal of verpleeginrigting, van die persoon in die Bylae hiervan genoem of ten opsigte van enige behandeling van of diens gelewer of goedere verskaf aan daardie persoon, kon insluit; en

(b) dat genoemde versekeraar nie ooreenkomstig artikel 26 (4) van die Wet verplig is nie om enige bedrag ten opsigte van sodanige koste te betaal aan enigeen wat die akkommodasie of behandeling verskaf of die diens gelewer of die goedere verskaf het en wat nie 'n skriftelike eis voor die verstryking van 'n tydperk van 60 dae na die datum van hierdie kennisgewing by bogenoemde versekeraar ingedien het nie.

Die besonderhede word verstrek in die volgorde, onder die naam en adres van die geregistreerde maatskappy; Naam van persoon/persone beseer of gedood; eisnommer; datum en plek van ongeluk; naam van hospitaal, verpleeginrigting of plek waar behandel (indien bekend).

NOTICE BY AUTHORISED INSURER OF AGREEMENT CONTEMPLATED IN SECTION 26 OF THE ACT

The authorised insurer named in the Schedule hereto, hereby gives notice in terms of section 26 (4) of the Act—

(a) that he has entered into an agreement contemplated in section 26 (3) (c) to make a payment in respect of a claim for compensation under section 21 of the said Act, which compensation could, if the said insurer were liable for payment thereof, have included costs in respect of the accommodation of the person named in the Schedule hereto in a hospital or a nursing home or of any treatment of or service rendered or goods supplied to that person; and

(b) that, in terms of section 26 (4) of the Act, the said insurer shall not be obliged to pay any amount in respect of such costs to any person who provided the accommodation or treatment or rendered the service or supplied the goods who has not lodged a claim, in writing, with the said insurer prior to the expiration of a period of 60 days after the date of this notice.

The particulars are given in the following order, under the name and address of the registered company: Name of person(s) injured or killed; claim number; date and place of accident; name of hospital, nursing home or place where treated (if known).

A.A. Mutual Insurance Association Ltd, P.O. Box 9595, Johannesburg, 2000

Mostert, P. J. Claim 2/6/71356. 13 January 1982, Roodepoort, Randfontein Road. Discovery Memorial Hospital.

General Accident Insurance Company South Africa Ltd, General Building, 110 Jorissen Street, Braamfontein, 2017

Jackson, Masiza Mtsi. Claim A/X1/90234 (K). 24/3/81, 47th Street, Elsies River, Cape. Conradie Hospital.

Protea Assurance Company Ltd, Box 7723, Johannesburg

Morrison, G. J. A. Claim 180108. 16/10/80, Edenvale. Kenridge Hospital.

Santamversekering Bpk., Posbus 653, Kaapstad, 8000

Keyzer, H. M. Eis 23/A/11028. 23 September 1980, Oberholzer. Sybrand van Niekerkhospitaal.

Eis 23/C/10372. 19 Junie 1982, Mabopane. Ga- Rankuwahospitaal.

1. Naam van die Geregistreerde maatskappy: Minister van Wet en Orde.
2. Naam van persoon beseer: Khoase; Selina Makoena.
3. Eisnommer: 22/7/5/43527R 3965/83 P3K.
4. Datum en plek van ongeluk: 26/12/81; Proteem swart woonbuurt, Sasolburg.

Plek van behandeling: Sebokeng Hospitaal.

R. H. KÖSTENS, NMS Staatsprokureur.

Werk mooi daarmee.

Ons leef  daarvan.

water is kosbaar

Use it.

Don't abuse  it.

water is for everybody

BELANGRIK!!

Plasing van tale:

Staatskoerante

1. Hiermee word bekendgemaak dat die omruil van tale in die *Staatskoerant* nie meer kwartaalliks gedoen word nie, maar dat dit jaarliks sal geskied, beginnende vanaf 1 Oktober tot 30 September, elke jaar.
2. Vir die tydperk 1 Oktober 1983 tot 30 September 1984 word Afrikaans EERSTE geplaas.
3. Hierdie reëling word in ooreenstemming gebring met dié van die Parlement waarby koerante met Wette ens. die taalvolgorde deurgaans behou vir die duur van die sitting.
4. Dit word dus van u, as adverteerder, verwag om u kopie met bogenoemde reëling te laat strook om onnodige omskakeling en stylredigering in ooreenstemming te bring.

—oOo—

IMPORTANT!!

Placing of languages:

Government Gazettes

1. Notice is hereby given that the interchange of languages in the *Government Gazette* no longer takes place quarterly, but that it will now be done annually, starting on 1 October until 30 September, every year.
2. For the period 1 October 1983 to 30 September 1984, Afrikaans is to be placed FIRST, changing annually hereafter.
3. This arrangement is to bring the *Government Gazettes* in conformity with Gazettes containing Acts of Parliament etc. where the language sequence remains constant throughout the sitting of Parliament.
4. It is therefore expected of you, the advertiser, to see that your copy is in accordance with the above-mentioned arrangement in order to avoid unnecessary style changes and editing to correspond with the correct style.

BONUS **OBLIGASIES**

MEER AS 1 400
PRYSE
ELKE MAAND



MORE THAN 1 400
PRIZES
EVERY MONTH

BONUS **BONDS**

**Spaar 'n sent en maak 'n rand —
Spaar 'n druppel en vul die dam**



Indien almal van ons besparingsbewus optree, besnoei ons nie slegs uitgawes nie maar wen ook ten opsigte van ons kosbare water- en elektrisiteitsvoorraad

Alle Proklamasies, Goewermentskennisgewings en Algemene Kennisgewings gepubliseer word vir verwysingsdoeleindes in die volgende inhoudsopgawe ingesluit wat dus 'n weeklikse indeks voorstel. Laat u self deur die Koerantnummers in die regterhandse kolom lei:

INHOUD

en weeklikse Indeks

No.		Bladsy No.	Staatskoerant No.
PROKLAMASIES			
R. 79	Wysigingswet op Voorkoming van Lugbesoedeling (21/1981): Datum van inwerking-treding van artikels 3, 4, 6 en 8	1	9242
84	Wet op Nasionale Paaië (54/1971): Verkla-ring van 'n nasionale pad: Provinsie die Kaap die Goeie Hoop	1	9247
89	Waterwet (54/1956): Umvoti-besproeiings-distrik, distrik Umvoti, Natal: Instelling.....	9	9247
90	do.: Mnyamvubu-besproeiingsdistrik, distrik Umvoti, Natal: Instelling	11	9247
91	Wysigingswet op die Wette op Vreemde-linge en Immigrasie (49/1984): Datum van inwerkingtreding	13	9247
GOEWERMEN- EN ALGEMENE KENNISGEWINGS			
Binnelandse Aangeleenthede, Departement van			
<i>Goewermentskennisgewings</i>			
1122	Wet op Publikasies (42/1974): Ongewenste publikasies of voorwerpe: Lys P84/48	1	9240
1123	do.: Publikasies of voorwerpe	1	9240
1124	do.: Vertoë kragtens artikel 24 (2) (b).....	2	9240
1125	do.: Publikasies of voorwerpe: Vertoë ten opsigte van appel	2	9240
1126	Wet op Publikasies (42/1974): Afkeuring van rolprent	13	9247
1127	do.: Ongewenste publikasies of voorwerpe: Lys P84/49	13	9247
1128	do.: Verbod op besit van ongewenste publi-kasies of voorwerpe	14	9247
1129	do.: Publikasies of voorwerpe: Vertoë ten opsigte van appel	14	9247
1140	Wet op Vreemdelinge (1/1937): Vansveran-dering: Kok in Randston	15	9247
Buitelandse Sake, Departement van			
<i>Goewermentskennisgewing</i>			
1158	Geloofsbriefoorhandiging: Dr. J. M. P. d. V. Boas	15	9247
Eerste Minister, Kantoor van die			
<i>Goewermentskennisgewing</i>			
1074	Wysigingswetsontwerp op Registrasie van Aktes (62/1984)	1	9241
Finansies, Departement van			
<i>Goewermentskennisgewings</i>			
R. 1094	Docane- en Aksynswet (91/1964): Tariefin-deling: TAR 99	1	9242
1115	Sluiting van oordragboeke	15	9247
<i>Algemene Kennisgewing</i>			
361	Voorlopige opgawe van handelstatistieke van die RSA	55	9247
Gemeenskapontwikkeling, Departement van			
<i>Goewermentskennisgewings</i>			
1149	Wet op Huurbeheer (80/1976): Van huurbe-heer onthef: Woning, motorhuis en bedien-dekamer: George	15	9247
1150	do.: do.: Wonings, motorstaanplekke en bediendekamers: Johannesburg	16	9247
1151	do.: do.: Wonings, motorhuise en bediende-kamers: Wysiging van Goewermentskennis-gewing	16	9247
1152	do.: do.: Wonings, motorstaanplekke en bediendekamers: Johannesburg	16	9247

For purposes of reference, all Proclamations, Government Notices and General Notices published are included in the following table of contents which thus forms a weekly index. Let yourself be guided by the Gazette numbers in the righthand column:

CONTENTS

and weekly Index

No.		Page No.	Gazette No.
PROCLAMATIONS			
R. 79	Atmospheric Pollution Prevention Amend-ment Act (21/1981): Date of commencement of sections 3, 4, 6 and 8	1	9242
84	National Roads Act (54/1971): Declaration of a national road: Province of the Cape of Good Hope	1	9247
89	Water Act (54/1956): Umvoti Irrigation Dis-trict, District of Umvoti, Natal: Establish-ment	9	9247
90	do.: Mnyamvubu Irrigation District, District of Umvoti, Natal: Establishment	11	9247
91	Aliens and Immigration Laws Amendment Act (49/1984): Date of commencement	13	9247
GOVERNMENT AND GENERAL NOTICES			
Agricultural, Department of			
<i>Government Notices</i>			
R. 1108	Marketing Act (59/1968): Winter, Cereal Scheme: Prices of flour, meal, semolina and self-raising flour: Amendment	19	9242
R. 1109	do.: do.: Special levy on white bread flour, brown bread meal and whole-wheat meal in stock at commercial bread bakers on 31 May 1984	22	9242
1118	Subdivision of Agricultural Land Act (70/1970): Exclusion of certain land in the Division of Outeniqua	18	9247
Community Development, Department of			
<i>Government Notices</i>			
1149	Rent Control Act (80/1976): Exempted from rent control: Dwelling, garage and servant's room: George	15	9247
1150	do.: do.: Dwellings, parking spaces and ser-vants' rooms: Johannesburg	16	9247
1151	do.: do.: Dwellings, garages and servants' rooms: Amendment of Government Notice	16	9247
1152	do.: do.: Dwellings, parking spaces and ser-vants' rooms: Johannesburg	16	9247
1153	do.: do.: Dwelling: Cape Town	17	9247
1154	do.: do.: Dwellings, garages and servants' rooms: Durban	17	9247
1155	do.: do.: Dwelling, garages and servants' rooms: Durban	17	9247
<i>General Notices</i>			
354	Community Development Act (3/1966): Determination of compensation	44	9247
362	Agrément Board of South Africa: Issuing of agrément certificate: No. 84/114	56	9247
363	do.: do.: No. 84/115	57	9247
364	do.: do.: No. 84/116	57	9247
365	do.: do.: No. 84/117	58	9247
366	do.: Acceptances of agrément certification	59	9247
367	do.: Change of certificate holder	54	9247
368	do.: Validity of certificate extended: No. 76/30	59	9247
369	do.: do.: No. 78/55	60	9247
370	do.: do.: No. 78/63	60	9247
371	do.: do.: No. 79/74	60	9247
372	do.: do.: No. 79/76	61	9247
373	do.: do.: No. 80/80	61	9247
374	do.: do.: No. 80/81	62	9247
375	do.: do.: No. 80/84	62	9247
376	do.: do.: No. 81/88	62	9247
377	do.: Change in certificate holder's list regis-tered	63	9247

No.		Bladsy No.	Staatskoerant No.	No.		Page No.	Gazette No.
1153	do.: do.: Woning: Kaapstad	17	9247	Constitutional Development and Planning, Department of			
1154	do.: do.: Wonings, motorhuise en bediende-kamers: Durban	17	9247	<i>Government Notice</i>			
1155	do.: do.: Woning, motorhuise en bediende-kamers: Durban	17	9247	1156	Statement of provincial revenue collections: 1 April 1983 to 31 March 1984.....	41	9247
Algemene Kennisgewings				Co-operation and Development, Department of			
354	Wet op Gemeenskapontwikkeling (3/1966): Bepaling van vergoeding.....	44	9247	<i>Government Notices</i>			
362	Agrément-raad van Suid-Afrika: Agrément-sertifikaat uitgereik: No. 84/114	56	9247	R. 1107	Black Local Authorities Act (102/1982): Water supply by-laws	27	9242
363	do.: do.: No. 84/115	57	9247	1134	KaNgwane Public Service Act (3/1979): KaNgwane Government: Prescribed apparatus	40	9247
364	do.: do.: No. 84/116	57	9247	1142	Townships Board, Natal: Appointment of alternate members.....	40	9247
365	do.: do.: No. 84/117	58	9247	<i>General Notice</i>			
366	do.: Aansoeke om agrément-sertifisering aanvaar	59	9247	357	Black Administration Act (38/1927): Southern Divorce Court: Sessions	63	9247
367	do.: Verandering van sertifikaathouer.....	54	9247	Environment Affairs, Department of			
368	do.: Geldigheidshouer van sertifikaat verleng: No. 76/30.....	59	9247	<i>General Notice</i>			
369	do.: do.: No. 78/55	60	9247	352	Water Act (54/1956): Titus River Irrigation Board, Division of Ceres, Cape Province: Assignment of functions, powers and duties	42	9247
370	do.: do.: No. 78/63	60	9247	Finance, Department of			
371	do.: do.: No. 79/74	60	9247	<i>Government Notices</i>			
372	do.: do.: No. 79/76	61	9247	R. 1094	Customs and Excise Act (91/1964): Tariff classification: TAR 99.....	1	9242
373	do.: do.: No. 80/80	61	9247	1115	Closing of transfer books	15	9247
374	do.: do.: No. 80/81	62	9247	<i>General Notice</i>			
375	do.: do.: No. 80/84	62	9247	361	Preliminary statement of trade statistics of the RSA	55	9247
376	do.: do.: No. 81/88	62	9247	Foreign Affairs, Department of			
377	do.: Verandering aan sertifikaathouer se lys geregistreer	63	9247	<i>Government Notice</i>			
Geondheid en Welsyn, Departement van				1158	Presentation of credentials: Dr J. M. P. d. V. Boas.....	15	9247
<i>Goewermenskennisgewings</i>				Health and Welfare, Department of			
R. 1083	Wet op die Voorkoming van Lugbesoedeling 1965: Regulasies betreffende brandstof verbruikende toestelle in wonings	5	9242	<i>Government Notices</i>			
R. 1097	Wet op Geneeshere, Tandartse en Aanvullende Gesondheidsdiensberoepse (56/1974): Die Suid-Afrikaanse Geneeskundige en Tandheelkundige Raad: Regulasies betreffende die registrasie deur geneeshere en tandartse van addisionele kwalifikasies: Wysiging.....	9	9242	R. 1083	Atmospheric Pollution Prevention Act, 1965: Regulations regarding fuel burning appliances in dwelling-houses.....	5	9242
R. 1098	do.: do.: Regulasies betreffende die kwalifikasies wat die reg op registrasie as sielkundiges verleen: Wysiging	10	9242	R. 1097	Medical Dental and Supplementary Health Service Professions Act (56/1974): The South African Medical and Dental Council: Regulations relating to the registration by medical practitioners and dentists of additional qualifications: Amendment.....	9	9242
R. 1099	do.: do.: Regulasies betreffende die verrigting van die werksaamhede van beroepsrade: Wysiging	11	9242	R. 1098	do.: do.: Regulations relating to the qualifications which entitle psychologists to registration: Amendment	10	9242
R. 1100	do.: do.: Regulasies wat die omvang van die beroep van brilopmaker omskryf	12	9242	R. 1099	do.: do.: Regulations relating to the conduct of the business of professional boards: Amendment.....	11	9242
R. 1101	do.: do.: Wysiging van die regulasies betreffende die kwalifikasies wat die reg op registrasie as sielkundige verleen.....	12	9242	R. 1100	do.: do.: Regulations defining the scope of the profession of optical dispensing	12	9242
R. 1102	do.: do.: Regulasies betreffende die voorwaardes waarop geregistreerde psigometriste hulle beroep mag beoefen: Wysiging.....	13	9242	R. 1101	do.: do.: Amendment of the regulations relating to the qualifications which entitle psychologists to registration	12	9242
R. 1103	do.: do.: Regulasies betreffende die registrasie deur optometriste van addisionele kwalifikasies: Wysiging	13	9242	R. 1102	do.: do.: Regulations relating to the conditions under which registered psychometrists may practice their profession: Amendment	13	9242
R. 1104	do.: do.: Regulasies betreffende die gebruik van sekere name slegs deur geregistreerde dieetkundiges	15	9242	R. 1103	do.: do.: Regulations relating to the registration by optometrists of additional qualifications: Amendment	13	9242
R. 1105	do.: do.: Regulasies betreffende die registrasie deur radiografiste van addisionele kwalifikasies	15	9242	R. 1104	do.: do.: Regulations relating to the use of certain names only by registered dietitians ...	15	9242
Algemene Kennisgewings				R. 1105	do.: do.: Regulations relating to the registration by radiographers of additional qualifications.....	15	9242
355	Wet op Aptekers (53/1974): Suid-Afrikaanse Aptekersraad: Persone skuldig bevind	45	9247	Justisie, Departement van			
358	Wet op die Beheer van Medisyne en Verwante Stowwe (101/1965): Registrasie van medisyne	46	9247	<i>Algemene Kennisgewing</i>			
Justisie, Departement van				359	Suid-Afrikaanse Regskommissie: Onderzoek: Termynse Waarbinne Regsgedinge teen die Staat Ingestel moet word.....	54	9247

No.	Bladsy No.	Staatskoerant No.
Landbou, Departement van		
<i>Goewermentskennisgewings</i>		
R. 1108		
Bemerkingswet (59/1968): Wintergraanskema: Pryse van meelblom, meel semolina en bruismeel: Wysiging	19	9242
R. 1109		
do.: Spesiale heffing op witbroodmeelblom, bruinbroodmeel en volkoringmeel in voorraad by kommersiële broodbakkers op 31 Mei 1984	22	9242
1118		
Wet op Onderverdeling van Landbougrond (70/1970): Uitsluiting van sekere grond in die afdeling Outeniqua	18	9247

No.	Bladsy No.	Staatskoerant No.
Mannekrag, Departement van		
<i>Goewermentskennisgewings</i>		
R. 1086		
Wet op Arbeidsverhoudinge (28/1956): Wassery-, Droogskoonmaak- en Kleurbedryf, Transvaal: Verlenging van Voorsorg- en Siektbystandfondsooreenkoms	23	9242
R. 1089		
Wet op Arbeidsverhoudinge (28/1956): Meubelnywerheid, Grens: Hernuwing van Opleidingsfondsooreenkoms	23	9242
R. 1090		
do.: Bounywerheid, Kimberley: Wysiging van Ooreenkoms vir die Elektriese Installeringseksie	23	9242
R. 1091		
do.: Kamstofekstielywerheid (Kaap): Hernuwing van Hofooreenkoms	25	9242
R. 1092		
do.: Wysiging van Hofooreenkoms	25	9242
R. 1157		
Wet op Arbeidsverhoudinge (28/1956): Vrugte-en Groente-inmaaknywerheid	1	9245

No.	Bladsy No.	Staatskoerant No.
Mineraal- en Energiesake, Departement van		
<i>Goewermentskennisgewings</i>		
1116		
Wet op Myne en Bedrywe (27/1956): Verklaring van werk in nasionale belang: Steenkoolmyne in landdrostrikte in die provinsies Transvaal, Natal en die Oranje-Vrystaat	18	9247
1144		
Wet op Mynregte (20/1967): Uitsluiting van sekere grond: Myndistrik Klerksdorp	19	9247
1145		
do.: Grond vir die afpenning van kleims oop verklaar: Myndistrik Pretoria	19	9247
1146		
do.: Uitsluiting van sekere grond: Myndistrik Oranje-Vrystaat	20	9247

No.	Bladsy No.	Staatskoerant No.
Nasionale Opvoeding, Departement van		
<i>Goewermentskennisgewing</i>		
1117		
Wet op Oorlogsgrafte en Nasionale Gedenkwaardighede (28/1956): Verklaring tot nasionale gedenkwaardigheid: Eiendom met kaffarianmuseumkompleks: King William's Town	20	9247

No.	Bladsy No.	Staatskoerant No.
Nywerheidswese en Handel, Departement van		
<i>Goewermentskennisgewings</i>		
R. 110		
Wet op Patente (57/1978): Wysiging van die regulasies	27	9242
1135		
Wet op Standaarde (30/1982): Verpligte spesifikasie: Veiligheidsbelms vir motorfietsryers	21	9247

No.	Bladsy No.	Staatskoerant No.
<i>Algemene Kennisgewing</i>		
347		
Maatskappywet (61/1973): Kennisgewings insake maatskappye	1	9243

No.	Bladsy No.	Staatskoerant No.
Omgewingsake, Departement van		
<i>Algemene Kennisgewing</i>		
352		
Waterwet (54/1956): Titusrivierbesproeiingsraad, afdeling Ceres, Kaapprovinsie: Toewysing van werksaamhede, bevoegdhede en pligte	42	9247

No.	Bladsy No.	Staatskoerant No.
Pos- en Telekommunikasiewese, Departement van		
<i>Algemene Kennisgewing</i>		
353		
Poswet (44/1958): Wysiging van die Tarieflys	42	9247

No.	Page No.	Gazette No.
<i>General Notices</i>		
355		
Pharmacy Act (53/1974): South African Pharmacy Board: Persons found guilty	45	9247
358		
Medicines and Related Substances Control Act (101/1965): Registration of medicines	46	9247

No.	Page No.	Gazette No.
Industries and Commerce, Department of		
<i>Government Notices</i>		
R. 1110		
Patents Act (57/1978): Amendment of regulations	27	9242
1135		
Standards Act (30/1982): Compulsory specification: Safety helmets for motor cyclists	21	9247

No.	Page No.	Gazette No.
<i>General Notice</i>		
347		
Companies Act (61/1973): Notices relating to companies	1	9243

No.	Page No.	Gazette No.
Internal Affairs, Department of		
<i>Government Notices</i>		
1122		
Publications Act (42/1974): Undesirable publications or objects: List P84/48	1	9240
1123		
do.: Publications or objects	1	9240
1124		
do.: Representations under section 24 (2) (b)	2	9240
1125		
do.: Publications or objects: Representations in respect of appeal	2	9240
1126		
Publications Act (42/1974): Rejection of film	13	9247
1127		
do.: Undesirable publications or objects: List P84/49	13	9247
1128		
do.: Prohibition on possession of undesirable publications or objects	14	9247
1129		
do.: Publications or objects: Representations in respect of appeal	14	9247
1140		
Aliens Act (1:1937): Change of surname: Kok to Randston	15	9247

No.	Page No.	Gazette No.
Justice, Department of		
<i>General Notice</i>		
359		
South African Law Commission: Investigation: Time Limits for the Institution of Actions against the State	54	9247

No.	Page No.	Gazette No.
Manpower, Department of		
<i>Government Notices</i>		
R. 1086		
Labour Relations Act (28/1956): Laundry, Dry Cleaning and Dyeing Trade, Transvaal: Extension of Provident and Sick Benefit Fund Agreement	23	9242
R. 1089		
Labour Relations Act (28/1956): Furniture Manufacturing Industry, Border: Renewal of Training Fund Agreement	23	9242
R. 1090		
do.: Building Industry, Kimberley: Amendment of Agreement for the Electrical Installation Section	23	9242
R. 1091		
do.: Worsted Textile Manufacturing Industry (Cape): Renewal of Main Agreement	25	9242
R. 1092		
do.: do.: Amendment of Main Agreement	25	9242
R. 1157		
Labour Relations Act (28/1956): Fruit and Vegetable Canning Industry	1	9245

No.	Page No.	Gazette No.
Mineral and Energy Affairs, Department of		
<i>Government Notices</i>		
1116		
Mines and Works Act (27/1956): Declaration of work in national interest: Coal mines in magisterial districts in the Provinces of the Transvaal, Natal and the Orange Free State	18	9247
1144		
Mining Rights Act (20/1967): Exemption of certain land: Mining District of Potchefstroom	19	9247
1145		
do.: Land declared open for the pegging of claims: Mining District of Pretoria	19	9247
1146		
do.: Exemption of certain land: Mining District of the Orange Free State	20	9247

No.	Bladsy No.	Staatskoerant No.	No.	Page No.	Gazette No.		
Samewerking en Ontwikkeling, Departement van			National Education, Department of				
<i>Goewermentskennisgewings</i>			<i>Government Notice</i>				
R. 1107	Wet op Swart Plaaslike Besture (102/1982): Watervoorsieningsverordeninge	27	9242	1117	War Graves and National Monuments Act (28/1956): Declared to be a national monument: Property with Kaffrarian Museum Complex: King William's Town	20	9247
1134	KaNgwane-wet op die Regeringsdiens (3/1979): KaNgwane Regeringsdiens: Voorgeskrewe apparaat	40	9247	Posts and Telecommunications, Department of			
1142	Dorperaad, Natal: Aanstelling van plaasvervangende lede	40	9247	<i>General Notice</i>			
<i>Algemene Kennisgewing</i>			353	Post Office Act (44/1958): Amendment of Tariff	42	9247	
357	Swart Administrasie Wet (38/1927): Suidelike Egskeidingshof: Sittings	63	9247	Prime Minister, Office of the			
Staatkundige Ontwikkeling en Beplanning, Departement van			<i>Government Notice</i>				
<i>Goewermentskennisgewing</i>			1074	Deeds Registries Amendment Act (62/1984)	1	9241	
1156	Staat van invorderings van provinsiale inkomste: 1 April 1983 tot 31 Maart 1984	41	9247	South African Transport Services			
Suid-Afrikaanse Vervoerdienste			<i>General Notice</i>				
<i>Algemene Kennisgewing</i>			360	Benefits payable from the New Railways and Harbours Superannuation Fund: The late Nico Stander	54	9247	
360	Voordele betaalbaar uit die Nuwe Spoorweg- en Hawesuperannuasiefonds: Wyle Nico Stander	54	9247	Transport, Department of			
Vervoer, Departement van			<i>Government Notice</i>				
<i>Goewermentskennisgewing</i>			R. 1093	Temporary exemption from certain overflight regulations	50	9242	
R. 1093	Tydlike vrystelling van sekere oorflug regulasies	50	9242	Official publications issued during March 1984			
Amptelike publikasies ontvang gedurende Maart 1984			65				
Belangrike aankondiging: Gewysigde sluitingstye vir wetlike en Goewermentskennisgewings			69				
WETLIKE ADVERTENSIES							
Algemene Voorwaardes en Tariewe			67				
Algemeen			117				
Besigheidskennisgewings			70				
Boedelwettekennisgewings			121				
Derdeparty-assuransie-eise			168				
Geregtelike en Openbare Verkope			91				
Handelsmerke in SWA			118				
Insolvensiewet- en Maatskappywette-kennisgewings			148				
Likwidaateurskennisgewings			83				
Maatskappykennisgewings			74				
Naamsverandering			115				
Orders van die Hof			85				
Publieke Veilings			91				
Slagterskennisgewings			116				
Tersydstellings en Afwysings van Aansoeke			113				
Verlore Lewensversekeringspolisse			162				
			Important announcement: Amended closing times for legal and Government notices				
			69				
LEGAL ADVERTISEMENTS							
General Conditions and Rates			67				
Administration of Estates Acts Notices			121				
Business Notices			70				
Butchers' Notices			116				
Change of Name			115				
Company Notices			74				
General			117				
Insolvency Acts and Companies Acts Notices			150				
Liquidators' Notices			83				
Lost Life Insurance Policies			162				
Orders of the Court			85				
Public Auctions			113				
Sales in Execution and Public Sales			91				
Supersessions and Discharge of Petitions			91				
Third Party Insurance Claims			168				
Trade Marks in SWA			118				