

REPUBLIEK
VAN
SUID-AFRIKA



REPUBLIC
OF
SOUTH AFRICA

Staatskoerant Government Gazette

Verkoopprys • Selling price
(AVB uitgesluit/GST excluded)

Plaaslik **50c** Local
Buitelands **70c** Other countries
Posvry • Post free

As 'n Nuusblad by die Poskantoor Geregistreer

Registered at the post office as a Newspaper

Vol. 268

PRETORIA, 16 OKTOBER 1987
OCTOBER 1987

No. 10987

PROKLAMASIE

van die

Staatspresident van die Republiek van Suid-Afrika

No. 153, 1987

DIE WET OP DIE VERVOERADVIESRAAD, 1987
(WET 58 VAN 1987)

Kragtens die bevoegdheid my verleen by artikel 18 van die Wet op die Vervoeradvisie, 1987 (Wet 58 van 1987), bepaal ek 15 Oktober 1987 as die datum waarop gemelde Wet in werking tree.

Gegee onder my Hand en die Seël van die Republiek van Suid-Afrika te Kaapstad, op hede die Dertigste dag van September Eenduisend Negehonderd Sewe-en-tagtig.

P. W. BOTHA,
Staatspresident.

Op las van die Staatspresident-in-Kabinet:

E. VAN DER M. LOUW,
Minister van die Kabinet.

GOEWERMENSKENNISGEWINGS

ADMINISTRASIE: VOLKSRAAD

DEPARTEMENT VAN PLAASLIKE BESTUUR,
BEHUISING EN WERKE

No. 2331

16 Oktober 1987

WET OP HUURBEHEER, 1976

VRYSTELLING VAN SEKERE WONINGS, MOTOR-
HUISE, MOTORSTAANPLEKKE EN BEDIENDE-
KAMERS VAN HUURBEHEER

Kragtens artikel 51 (g) van die Wet op Huurbeheer, 1976 (Wet 80 van 1976), verklaar ek, Abraham Adriaan Venter, Minister van Plaaslike Bestuur, Behuising en Werke hierby dat—

- (a) die wonings genoem in Bylae A, met ingang van die datum van hierdie Kennisgewing;

547—1

PROCLAMATION

by the

State President of the Republic of South Africa

No. 153, 1987

TRANSPORT ADVISORY COUNCIL ACT, 1987
(ACT 58 OF 1987)

By virtue of the powers vested in me by section 18 of the Transport Advisory Council Act, 1987 (Act 58 of 1987), I fix 15 October 1987 as the date on which the said Act shall come into operation.

Given under my Hand and the Seal of the Republic of South Africa at Cape Town on this Thirtieth day of September, One thousand Nine hundred and Eighty-seven.

P. W. BOTHA,
State President.

By Order of the State President-in-Cabinet:

E. VAN DER M. LOUW,
Minister of the Cabinet.

GOVERNMENT NOTICES

ADMINISTRATION: HOUSE OF ASSEMBLY

DEPARTMENT OF LOCAL GOVERNMENT,
HOUSING AND WORKS

No. 2331

16 October 1987

RENT CONTROL ACT, 1976

EXEMPTION OF CERTAIN DWELLINGS, GARAGES,
PARKING SPACES AND SERVANT'S ROOMS FROM
RENT CONTROL

Under section 51 (g) of the Rent Control Act, 1976 (Act 80 of 1976), I, Abraham Adriaan Venter, Minister of Local Government, Housing and Works, hereby declare that—

- (a) the dwellings mentioned in Annexure A are, as from the date of this Notice;

10987—1

- (b) die wonings genoem in Bylae B, met ingang van die datum waarop 'n bestaande huurder van so 'n woning se okkupasie wettiglik beëindig word of die datum waarop sodanige huurder se maandelikse inkomste soos omskryf in Proklamasie 32 van 25 Maart 1983, soos gewysig by Proklamasie 99 van 1 Julie 1983, en Proklamasie 24 van 20 Februarie 1987, die toepaslike inkomsteperk vermeld in die Bylae by eersgenoemde Proklamasie, soos aldus gewysig, naamlik R1 250 ten opsigte van 'n huurder wat 'n gesinshoof met afhanklikes is of R750 ten opsigte van 'n enkelopende huurder sonder afhanklikes, oorskry, welke datum ook al eerste voorval, mits die betrokke huurder op die betrokke datum nie 70 jaar of ouer is nie; en
- (c) die motorhuise, motorstaanplekke en bediendekamers geleë op enige plek op grond wat deel uitmaak van grond wat geokkupeer word deur of gebruik word in verband met die wonings in paragraaf (a) of (b) hierbo bedoel, met ingang van die toepaslike datum in die betrokke paragraaf bedoel,

van huurbeheer vrygestel is, op voorwaarde dat, behoudens die bepalinge van artikel 28 van genoemde Wet op Huurbeheer, 1976, gedurende 'n tydperk van drie kalendermaande vanaf die datum van vrystelling van die betrokke perseel van huurbeheer die verhuurder nie van die huurder mag vereis om die perseel te ontruim nie, en voorts dat gedurende 'n tydperk van twee jaar vanaf die datum van vrystelling van die betrokke perseel die huurgeld ten opsigte daarvan nie met meer as 10 % per jaar verhoog mag word nie.

A. A. VENTER,
Minister van Plaaslike Bestuur, Behuising en Werke.

- (b) the dwellings mentioned in Annexure B are, as from the date on which the occupation of an existing lessee of such a dwelling is lawfully terminated or the date on which the monthly income of such lessee, as defined in Proclamation 32 of 25 March 1983, as amended by Proclamation 99 of 1 July 1983, and Proclamation 24 of 20 February 1987, exceeds the applicable income limit stipulated in the Schedule to the first-mentioned Proclamation, as so amended, namely R1 250 in respect of a lessee who is the head of a family with dependants or R750 in respect of a single lessee without dependants, whichever date occurs first, provided the lessee in question on the applicable date is not 70 years of age or older; and
- (c) the garages, parking spaces and servants' rooms situated anywhere on land which forms part of land occupied or used in connection with the dwellings referred to in paragraph (a) or (b) above, are, as from the applicable date referred to in the relevant paragraph,

exempted from rent control, on condition that, subject to the provisions of section 28 of the said Rent Control Act, 1976, during a period of three calendar months as from the date of exemption of the relevant premises from rent control, the lessor may not require the lessee to vacate the premises, and further that during a period of two years as from the date of exemption of the relevant premises the rental in respect thereof shall not be increased by more than 10 % per annum.

A. A. VENTER,
Minister of Local Government, Housing and Works.

BYLAE A

Adres van eiendom

Ligging van eiendom

Constitution Hill 23, Port Elizabeth Sentraal	Erf 1936, Port Elizabeth Sentraal.
Constitution Hill 43, Port Elizabeth Sentraal	Erf 1993, Port Elizabeth Sentraal.
Cooperstraat 13 en 17, Port Elizabeth Sentraal	Erf 2944, Port Elizabeth Sentraal.

BYLAE B

Adres van eiendom

Ligging van eiendom

Constitution Hill 25, Port Elizabeth Sentraal	Erf 1938, Port Elizabeth Sentraal.
Constitution Hill 27, Port Elizabeth Sentraal	Erf 1939, Port Elizabeth Sentraal.
Constitution Hill 31, Port Elizabeth Sentraal	Erf 1953, Port Elizabeth Sentraal.
Constitution Hill 39, Port Elizabeth Sentraal	Erf 1977, Port Elizabeth Sentraal.
Constitution Hill 41, Port Elizabeth Sentraal	Erf 1944, Port Elizabeth Sentraal.
Cooperstraat 5, Port Elizabeth Sentraal	Erf 3146, Port Elizabeth Sentraal.
Cooperstraat 6, Port Elizabeth Sentraal	Erf 2955, Port Elizabeth Sentraal.
Cooperstraat 7, Port Elizabeth Sentraal	Erf 2945, Port Elizabeth Sentraal.
Cooperstraat 12, Port Elizabeth Sentraal	Erf 3164, Port Elizabeth Sentraal.
Cooperstraat 15, Port Elizabeth Sentraal	Erf 2944, Port Elizabeth Sentraal.
Crossstraat 2a, Port Elizabeth Sentraal	Erf 4783, Port Elizabeth Sentraal.
Crossstraat 5, Port Elizabeth Sentraal	Erf 919, Port Elizabeth Sentraal.
Cuylersingel 20, Port Elizabeth Sentraal	Erf 3675, Port Elizabeth Sentraal.
Cuylersingel 21 en 21a, Port Elizabeth Sentraal	Erf 3937, Port Elizabeth Sentraal.
Cuylersingel 22, Port Elizabeth Sentraal	Erf 3676, Port Elizabeth Sentraal.
Cuylersingel 30a en 30d, Port Elizabeth Sentraal	Erf 3679, Port Elizabeth Sentraal.
Cuylersingel 31, Port Elizabeth Sentraal	Erf 3646, Port Elizabeth Sentraal.
Cuylersingel 33, Port Elizabeth Sentraal	Erf 3645, Port Elizabeth Sentraal.
Cuylersingel 35, Port Elizabeth Sentraal	Erf 3644, Port Elizabeth Sentraal.
Cuylersingel 3, Port Elizabeth Sentraal	Erf 3926, Port Elizabeth Sentraal.
Donkinstraat 25, Port Elizabeth Sentraal	Erf 1910, Port Elizabeth Sentraal.
Cuylersingel 32, Port Elizabeth Sentraal	Erf 3541, Port Elizabeth Sentraal.
Cuylersingel 34, Port Elizabeth Sentraal	Erf 3540, Port Elizabeth Sentraal.
Cuylersingel 38, Port Elizabeth Sentraal	Erf 3538, Port Elizabeth Sentraal.
Doncasterstraat 2, Port Elizabeth Sentraal	Erf 3347, Port Elizabeth Sentraal.
Donkinstraat 27, Port Elizabeth Sentraal	Erf 1913, Port Elizabeth Sentraal.
Donkinstraat 29, Port Elizabeth Sentraal	Erf 1911, Port Elizabeth Sentraal.

Adres van eiendom

Donkinstraat 31 en 31a, Port Elizabeth Sentraal
Donkinstraat 39, Port Elizabeth Sentraal
Donkinstraat 41, Port Elizabeth Sentraal
Donkinstraat 43, Port Elizabeth Sentraal
Donkinstraat 47, Port Elizabeth Sentraal
Donkinstraat 49, Port Elizabeth Sentraal
Donkinstraat 51, Port Elizabeth Sentraal
Donkinstraat 53, Port Elizabeth Sentraal

Ligging van eiendom

Erf 1916, Port Elizabeth Sentraal.
Erf 1921, Port Elizabeth Sentraal.
Erf 1920, Port Elizabeth Sentraal.
Erf 1922, Port Elizabeth Sentraal.
Erf 1924, Port Elizabeth Sentraal.
Erf 1923, Port Elizabeth Sentraal.
Erf 1925, Port Elizabeth Sentraal.
Erf 1926, Port Elizabeth Sentraal.

ANNEXURE A

Adress of premises

23 Constitution Hill, Port Elizabeth Central
43 Constitution Hill, Port Elizabeth Central
13 and 17 Cooper Street, Port Elizabeth Central

Situation of premises

Erf 1936, Port Elizabeth Central.
Erf 1993, Port Elizabeth Central.
Erf 2944, Port Elizabeth Central.

ANNEXURE B

Adress of premises

25 Constitution Hill, Port Elizabeth Central
27 Constitution Hill, Port Elizabeth Central
31 Constitution Hill, Port Elizabeth Central
39 Constitution Hill, Port Elizabeth Central
41 Constitution Hill, Port Elizabeth Central
5 Cooper Street, Port Elizabeth Central
6 Cooper Street, Port Elizabeth Central
7 Cooper Street, Port Elizabeth Central
12 Cooper Street, Port Elizabeth Central
15 Cooper Street, Port Elizabeth Central
2a Cross Street, Port Elizabeth Central
5 Cross Street, Port Elizabeth Central
20 Cuyler Circle, Port Elizabeth Central
21 and 21a Cuyler Circle, Port Elizabeth Central
22 Cuyler Circle, Port Elizabeth Central
30a and 30d Cuyler Circle, Port Elizabeth Central
31 Cuyler Circle, Port Elizabeth Central
33 Cuyler Circle, Port Elizabeth Central
35 Cuyler Circle, Port Elizabeth Central
3 Cuyler Circle, Port Elizabeth Central
25 Donkin Street, Port Elizabeth Central
32 Cuyler Circle, Port Elizabeth Central
34 Cuyler Circle, Port Elizabeth Central
38 Cuyler Circle, Port Elizabeth Central
2 Doncaster Street, Port Elizabeth Central
27 Donkin Street, Port Elizabeth Central
29 Donkin Street, Port Elizabeth Central
31 and 31a Donkin Street, Port Elizabeth Central
39 Donkin Street, Port Elizabeth Central
41 Donkin Street, Port Elizabeth Central
43 Donkin Street, Port Elizabeth Central
47 Donkin Street, Port Elizabeth Central
49 Donkin Street, Port Elizabeth Central
51 Donkin Street, Port Elizabeth Central
53 Donkin Street, Port Elizabeth Central

Situation of premises

Erf 1938, Port Elizabeth Central.
Erf 1939, Port Elizabeth Central.
Erf 1953, Port Elizabeth Central.
Erf 1977, Port Elizabeth Central.
Erf 1944, Port Elizabeth Central.
Erf 3146, Port Elizabeth Central.
Erf 2955, Port Elizabeth Central.
Erf 2945, Port Elizabeth Central.
Erf 3164, Port Elizabeth Central.
Erf 2944, Port Elizabeth Central.
Erf 4783, Port Elizabeth Central.
Erf 919, Port Elizabeth Central.
Erf 3675, Port Elizabeth Central.
Erf 3937, Port Elizabeth Central.
Erf 3676, Port Elizabeth Central.
Erf 3679, Port Elizabeth Central.
Erf 3646, Port Elizabeth Central.
Erf 3645, Port Elizabeth Central.
Erf 3644, Port Elizabeth Central.
Erf 3926, Port Elizabeth Central.
Erf 1910, Port Elizabeth Central.
Erf 3541, Port Elizabeth Central.
Erf 3540, Port Elizabeth Central.
Erf 3538, Port Elizabeth Central.
Erf 3347, Port Elizabeth Central.
Erf 1913, Port Elizabeth Central.
Erf 1911, Port Elizabeth Central.
Erf 1916, Port Elizabeth Central.
Erf 1921, Port Elizabeth Central.
Erf 1920, Port Elizabeth Central.
Erf 1922, Port Elizabeth Central.
Erf 1924, Port Elizabeth Central.
Erf 1923, Port Elizabeth Central.
Erf 1925, Port Elizabeth Central.
Erf 1926, Port Elizabeth Central.

**DEPARTEMENT VAN PLAASLIKE BESTUUR
BEHUISING EN WERKE**

No. 2332 16 Oktober 1987

WET OP HUURBEHEER, 1976

**VRYSTELLING VAN SEKERE WONINGS, MOTOR-
HUISE, MOTORSTAANPLEKKE EN BEDIENDE-
KAMERS VAN HUURBEHEER**

Kragtens artikel 51 (g) van die Wet op Huurbeheer, 1976 (Wet 80 van 1976), verklaar ek, Abraham Adriaan Venter, Minister van Plaaslike Bestuur, Behuising en Werke hierby dat—

- (a) die wonings genoem in Bylae A, met ingang van die datum van hierdie Kennisgewing;

**DEPARTMENT OF LOCAL GOVERNMENT
HOUSING AND WORKS**

No. 2332 16 October 1987

RENT CONTROL ACT, 1976

**EXEMPTION OF CERTAIN DWELLINGS, GARAGES,
PARKING SPACES AND SERVANT'S ROOMS FROM
RENT CONTROL**

Under section 51 (g) of the Rent Control Act, 1976 (Act 80 of 1976), I, Abraham Adriaan Venter, Minister of Local Government, Housing and Works, hereby declare that—

- (a) the dwellings mentioned in Annexure A are, as from the date of this Notice;

- (b) die wonings genoem in Bylae B, met ingang van die datum waarop 'n bestaande huurder van so 'n woning se okkupasie wettiglik beëindig word of die datum waarop sodanige huurder se maandelikse inkomste soos omskryf in Proklamasie 32 van 25 Maart 1983, soos gewysig by Proklamasie 99 van 1 Julie 1983, en Proklamasie 24 van 20 Februarie 1987, die toepaslike inkomsteperk vermeld in die Bylae by eersgenoemde Proklamasie, soos aldus gewysig, naamlik R1 250 ten opsigte van 'n huurder wat 'n gesinshoof met afhanklikes is of R750 ten opsigte van 'n enkellopende huurder sonder afhanklikes, oorskry, welke datum ook al eerste voorval, mits die betrokke huurder op die betrokke datum nie 70 jaar of ouer is nie; en
- (c) die motorhuise, motorstaanplekke en bediendekamers geleë op enige plek op grond wat deel uitmaak van grond wat geokkupeer word deur of gebruik word in verband met die wonings in paragraaf (a) of (b) hierbo bedoel, met ingang van die toepaslike datum in die betrokke paragraaf bedoel,

van huurbeheer vrygestel is, op voorwaarde dat, behoudens die bepalinge van artikel 28 van genoemde Wet op Huurbeheer, 1976, gedurende 'n tydperk van drie kalendermaande vanaf die datum van vrystelling van die betrokke perseel van huurbeheer die verhuurder nie van die huurder mag vereis om die perseel te ontruim nie, en voorts dat gedurende 'n tydperk van twee jaar vanaf die datum van vrystelling van die betrokke perseel die huurgeld ten opsigte daarvan nie met meer as 10 % per jaar verhoog mag word nie.

A. A. VENTER,
Minister van Plaaslike Bestuur, Behuising en Werke.

- (b) the dwellings mentioned in Annexure B are, as from the date on which the occupation of an existing lessee of such a dwelling is lawfully terminated or the date on which the monthly income of such lessee, as defined in Proclamation 32 of 25 March 1983, as amended by Proclamation 99 of 1 July 1983, and Proclamation 24 of 20 February 1987, exceeds the applicable income limit stipulated in the Schedule to the first-mentioned Proclamation, as so amended, namely R1 250 in respect of a lessee who is the head of a family with dependants or R750 in respect of a single lessee without dependants, whichever date occurs first, provided the lessee in question on the applicable date is not 70 years of age or older; and
- (c) the garages, parking spaces and servant's rooms situated anywhere on land which forms part of land occupied or used in connection with the dwellings referred to in paragraph (a) or (b) above, are, as from the applicable date referred to in the relevant paragraph,

exempted from rent control, on condition that, subject to the provisions of section 28 of the said Rent Control Act, 1976, during a period of three calendar months as from the date of exemption of the relevant premises from rent control, the lessor may not require the lessee to vacate the premises, and further that during a period of two years as from the date of exemption of the relevant premises the rental in respect thereof shall not be increased by more than 10 % per annum.

A. A. VENTER,
Minister of Local Government, Housing and Works.

BYLAE A

Adres van eiendom

- Kemsleystraat 1, Port Elizabeth Sentraal.....
- Geraldstraat 45, Newton Park, Port Elizabeth.....
- Derde Laan 15, Newton Park, Port Elizabeth.....
- Derde Laan 32, Newton Park, Port Elizabeth.....

Ligging van eiendom

- Erf 965, Port Elizabeth Sentraal
- Erf 739, Port Elizabeth te Newton Park.
- Erf 2125, Port Elizabeth te Newton Park.
- Erf 2811, Port Elizabeth te Newton Park.

BYLAE B

Adres van eiendom

- Gordon Terrace 8 en 10, Port Elizabeth Sentraal.....
- Gordon Terrace 14 en 16, Port Elizabeth Sentraal.....
- Gordon Terrace 18 en 18A, Port Elizabeth Sentraal.....
- Gordon Terrace 20, Port Elizabeth Sentraal.....
- Gordon Terrace 28, Port Elizabeth Sentraal.....
- Gordon Terrace 36, Port Elizabeth Sentraal.....
- Gordon Terrace 38, Port Elizabeth Sentraal.....
- Gordon Terrace 44, Port Elizabeth Sentraal.....
- Gordon Terrace 46, Port Elizabeth Sentraal.....
- Glenstraat 1, Port Elizabeth Sentraal.....
- Glenstraat 2, Port Elizabeth Sentraal.....
- Glenstraat 3, Port Elizabeth Sentraal.....
- Glenstraat 4, Port Elizabeth Sentraal.....
- Glenstraat 5, Port Elizabeth Sentraal.....
- Glenstraat 6, Port Elizabeth Sentraal.....
- Glenstraat 7 en 7a, Port Elizabeth Sentraal.....
- Glenstraat 8, Port Elizabeth Sentraal.....
- Glenstraat 9, Port Elizabeth Sentraal.....
- Glenstraat 11, Port Elizabeth Sentraal.....
- Glenstraat 15, Port Elizabeth Sentraal.....
- Glenstraat 23, Port Elizabeth Sentraal.....
- Kemsleystraat 2, Port Elizabeth Sentraal.....
- Kemsleystraat 13, Port Elizabeth Sentraal.....
- Kemsleystraat 4, Port Elizabeth Sentraal.....
- Kemsleystraat 5, Port Elizabeth Sentraal.....
- Kemsleystraat 7, Port Elizabeth Sentraal.....
- Kemsleystraat 8, Port Elizabeth Sentraal.....
- Irvinestraat 86, Port Elizabeth Sentraal.....
- Irvinestraat 80, Port Elizabeth Sentraal.....

Ligging van eiendom

- Erf 4510, Port Elizabeth Sentraal.
- Erf 4776, Port Elizabeth Sentraal.
- Erf 3563, Port Elizabeth Sentraal.
- Erf 3562, Port Elizabeth Sentraal.
- Erf 3873, Port Elizabeth Sentraal.
- Erf 3550, Port Elizabeth Sentraal.
- Erf 3549, Port Elizabeth Sentraal.
- Erf 3546, Port Elizabeth Sentraal.
- Erf 3545, Port Elizabeth Sentraal.
- Erf 610, Port Elizabeth Sentraal.
- Erf 2949, Port Elizabeth Sentraal.
- Erf 512, Port Elizabeth Sentraal.
- Erf 315, Port Elizabeth Sentraal.
- Erf 868, Port Elizabeth Sentraal.
- Erf 315, Port Elizabeth Sentraal.
- Erf 514, Port Elizabeth Sentraal.
- Erf 948, Port Elizabeth Sentraal.
- Erf 515, Port Elizabeth Sentraal.
- Erf 866, Port Elizabeth Sentraal.
- Erf 519, Port Elizabeth Sentraal.
- Erf 525, Port Elizabeth Sentraal.
- Erf 978, Port Elizabeth Sentraal.
- Erf 948, Port Elizabeth Sentraal.
- Erf 977, Port Elizabeth Sentraal.
- Erf 964, Port Elizabeth Sentraal.
- Erf 963, Port Elizabeth Sentraal.
- Erf 975, Port Elizabeth Sentraal.
- Erf 507, Port Elizabeth Sentraal.
- Erf 505, Port Elizabeth Sentraal.

Adres van eiendom

Ligging van eiendom

Irvinestraat 78, Port Elizabeth Sentraal	Erf 772, Port Elizabeth Sentraal.
Irvinestraat 76, Port Elizabeth Sentraal	Erf 502, Port Elizabeth Sentraal.
Irvinestraat 75, Port Elizabeth Sentraal	Erf 639, Port Elizabeth Sentraal.
Irvinestraat 73, Port Elizabeth Sentraal	Erf 640, Port Elizabeth Sentraal.
Irvinestraat 71, Port Elizabeth Sentraal	Erf 472, Port Elizabeth Sentraal.
Irvinestraat 69, Port Elizabeth Sentraal	Erf 481, Port Elizabeth Sentraal.
Irvinestraat 62 en 64, Port Elizabeth Sentraal.....	Erf 495, Port Elizabeth Sentraal.
Irvinestraat 61, Port Elizabeth Sentraal	Erf 698, Port Elizabeth Sentraal.
Irvinestraat 60, Port Elizabeth Sentraal	Erf 494, Port Elizabeth Sentraal.
Irvinestraat 59, Port Elizabeth Sentraal	Erf 462, Port Elizabeth Sentraal.
Irvinestraat 58, Port Elizabeth Sentraal	Erf 694, Port Elizabeth Sentraal.
Irvinestraat 57, Port Elizabeth Sentraal	Erf 462, Port Elizabeth Sentraal.
Irvinestraat 56, Port Elizabeth Sentraal	Erf 492, Port Elizabeth Sentraal.
Irvinestraat 53 en 55, Port Elizabeth Sentraal.....	Erf 461, Port Elizabeth Sentraal.
Irvinestraat 48, Port Elizabeth Sentraal	Erf 489, Port Elizabeth Sentraal.
Irvinestraat 47, Port Elizabeth Sentraal	Erf 887, Port Elizabeth Sentraal.
Irvinestraat 46, Port Elizabeth Sentraal	Erf 486, Port Elizabeth Sentraal.
Moffatstraat 9, Port Elizabeth Sentraal	Erf 816, Port Elizabeth Sentraal.
Moffatstraat 7, Port Elizabeth Sentraal	Erf 814, Port Elizabeth Sentraal.
Militaryweg 38, Port Elizabeth Sentraal	Erf 3648, Port Elizabeth Sentraal.
Militaryweg 13 en 15, Port Elizabeth Sentraal	Erf 3798, Port Elizabeth Sentraal.
Militaryweg 11, Port Elizabeth Sentraal	Erf 3797, Port Elizabeth Sentraal.
Militaryweg 1, Port Elizabeth Sentraal	Erf 3792, Port Elizabeth Sentraal.
Geraldstraat 22, Newton Park, Port Elizabeth	Erf 1228, Port Elizabeth te Newton Park.
Geraldstraat 34, Newton Park, Port Elizabeth	Erf 1208, Port Elizabeth te Newton Park.
Geraldstraat 44, Newton Park, Port Elizabeth	Erf 1199, Port Elizabeth te Newton Park.
Geraldstraat 61, Newton Park, Port Elizabeth	Erf 747, Port Elizabeth te Newton Park.
Derde Laan 8, Newton Park, Port Elizabeth	Erf 2171, Port Elizabeth te Newton Park.
Derde Laan 17, Newton Park, Port Elizabeth	Erf 2102, Port Elizabeth te Newton Park.
Derde Laan 19, Newton Park, Port Elizabeth	Erf 2103, Port Elizabeth te Newton Park.
Derde Laan 28, Newton Park, Port Elizabeth	Erf 1965, Port Elizabeth te Newton Park.
Derde Laan 37, Newton Park, Port Elizabeth	Erf 1834, Port Elizabeth te Newton Park.
Derde Laan 43 en 45, Newton Park, Port Elizabeth	Erf 1517, Port Elizabeth te Newton Park.
Derde Laan 49, Newton Park, Port Elizabeth	Erf 1568, Port Elizabeth te Newton Park.
Derde Laan 51, Newton Park, Port Elizabeth	Erf 1836, Port Elizabeth te Newton Park.
Kinnersleystraat 3, Newton Park, Port Elizabeth	Erf 1125, Port Elizabeth te Newton Park.
Kinnersleystraat 13, Newton Park, Port Elizabeth	Erf 1116, Port Elizabeth te Newton Park.
Kinnersleystraat 14, Newton Park, Port Elizabeth	Erf 1151, Port Elizabeth te Newton Park.
Kinnersleystraat 40, Newton Park, Port Elizabeth	Erf 1184, Port Elizabeth te Newton Park.
Kinnersleystraat 44, Newton Park, Port Elizabeth	Erf 1188, Port Elizabeth te Newton Park.
Kinnersleystraat 45, Newton Park, Port Elizabeth	Erf 710, Port Elizabeth te Newton Park.
Kinnersleystraat 47, Newton Park, Port Elizabeth	Erf 711, Port Elizabeth te Newton Park.
Kinnersleystraat 55, Newton Park, Port Elizabeth	Erf 715, Port Elizabeth te Newton Park.
King Edwardstraat 11, Newton Park, Port Elizabeth	Erf 2168, Port Elizabeth te Newton Park.
King Edwardstraat 32, Newton Park, Port Elizabeth	Erf 2060, Port Elizabeth te Newton Park.
King Edwardstraat 39, Newton Park, Port Elizabeth	Erf 2051, Port Elizabeth te Newton Park.
King Edwardstraat 46, Newton Park, Port Elizabeth	Erf 153, Port Elizabeth te Newton Park.
King Edwardstraat 48, Newton Park, Port Elizabeth	Erf 152, Port Elizabeth te Newton Park.
King Edwardstraat 49, Newton Park, Port Elizabeth	Erf 94, Port Elizabeth te Newton Park.
King Edwardstraat 51, Newton Park, Port Elizabeth	Erf 95/96, Port Elizabeth te Newton Park.
King Edwardstraat 56, Newton Park, Port Elizabeth	Erf 133, Port Elizabeth te Newton Park.

ANNEXURE A

Address of premises

Situation of premises

1 Kemsley Street, Port Elizabeth Central	Erf 965, Port Elizabeth Central.
45 Gerald Street, Newton Park, Port Elizabeth	Erf 739, Port Elizabeth at Newton Park.
15 Third Avenue, Newton Park, Port Elizabeth	Erf 2125, Port Elizabeth at Newton Park.
32 Third Avenue, Newton Park, Port Elizabeth	Erf 2811, Port Elizabeth at Newton Park.

ANNEXURE B

Address of premises

Situation of premises

8 and 10 Gordon Terrace, Port Elizabeth Central	Erf 4510, Port Elizabeth Central.
14 and 16 Gordon Terrace, Port Elizabeth Central	Erf 4776, Port Elizabeth Central.
18 and 18A Gordon Terrace, Port Elizabeth Central	Erf 3563, Port Elizabeth Central.
20 Gordon Terrace, Port Elizabeth Central	Erf 3562, Port Elizabeth Central.
28 Gordon Terrace, Port Elizabeth Central	Erf 3873, Port Elizabeth Central.
36 Gordon Terrace, Port Elizabeth Central	Erf 3550, Port Elizabeth Central.
38 Gordon Terrace, Port Elizabeth Central	Erf 3549, Port Elizabeth Central.
44 Gordon Terrace, Port Elizabeth Central	Erf 3546, Port Elizabeth Central.
46 Gordon Terrace, Port Elizabeth Central	Erf 3545, Port Elizabeth Central.
1 Glen Street, Port Elizabeth Central	Erf 610, Port Elizabeth Central.
2 Glen Street, Port Elizabeth Central	Erf 2949, Port Elizabeth Central.

<i>Address of premises</i>	<i>Situation of premises</i>
3 Glen Street, Port Elizabeth Central	Erf 512, Port Elizabeth Central.
4 Glen Street, Port Elizabeth Central	Erf 315, Port Elizabeth Central.
5 Glen Street, Port Elizabeth Central	Erf 868, Port Elizabeth Central.
6 Glen Street, Port Elizabeth Central	Erf 315, Port Elizabeth Central.
7 and 7a Glen Street, Port Elizabeth Central	Erf 514, Port Elizabeth Central.
8 Glen Street, Port Elizabeth Central	Erf 948, Port Elizabeth Central.
9 Glen Street, Port Elizabeth Central	Erf 515, Port Elizabeth Central.
11 Glen Street, Port Elizabeth Central	Erf 866, Port Elizabeth Central.
15 Glen Street, Port Elizabeth Central	Erf 519, Port Elizabeth Central.
23 Glen Street, Port Elizabeth Central	Erf 525, Port Elizabeth Central.
23 Glen Street, Port Elizabeth Central	Erf 525, Port Elizabeth Central.
2 Kemsley Street, Port Elizabeth Central	Erf 978, Port Elizabeth Central.
13 Kemsley Street, Port Elizabeth Central	Erf 948, Port Elizabeth Central.
4 Kemsley Street, Port Elizabeth Central	Erf 977, Port Elizabeth Central.
5 Kemsley Street, Port Elizabeth Central	Erf 964, Port Elizabeth Central.
7 Kemsley Street, Port Elizabeth Central	Erf 963, Port Elizabeth Central.
8 Kemsley Street, Port Elizabeth Central	Erf 975, Port Elizabeth Central.
86 Irvine Street, Port Elizabeth Central	Erf 507, Port Elizabeth Central.
80 Irvine Street, Port Elizabeth Central	Erf 505, Port Elizabeth Central.
78 Irvine Street, Port Elizabeth Central	Erf 772, Port Elizabeth Central.
76 Irvine Street, Port Elizabeth Central	Erf 502, Port Elizabeth Central.
75 Irvine Street, Port Elizabeth Central	Erf 639, Port Elizabeth Central.
73 Irvine Street, Port Elizabeth Central	Erf 640, Port Elizabeth Central.
71 Irvine Street, Port Elizabeth Central	Erf 472, Port Elizabeth Central.
69 Irvine Street, Port Elizabeth Central	Erf 481, Port Elizabeth Central.
64 Irvine Street, Port Elizabeth Central	Erf 495, Port Elizabeth Central.
61 Irvine Street, Port Elizabeth Central	Erf 698, Port Elizabeth Central.
60 Irvine Street, Port Elizabeth Central	Erf 494, Port Elizabeth Central.
59 Irvine Street, Port Elizabeth Central	Erf 462, Port Elizabeth Central.
58 Irvine Street, Port Elizabeth Central	Erf 694, Port Elizabeth Central.
57 Irvine Street, Port Elizabeth Central	Erf 462, Port Elizabeth Central.
56 Irvine Street, Port Elizabeth Central	Erf 492, Port Elizabeth Central.
53 and 55 Irvine Street, Port Elizabeth Central	Erf 461, Port Elizabeth Central.
48 Irvine Street, Port Elizabeth Central	Erf 489, Port Elizabeth Central.
47 Irvine Street, Port Elizabeth Central	Erf 887, Port Elizabeth Central.
46 Irvine Street, Port Elizabeth Central	Erf 486, Port Elizabeth Central.
9 Moffat Street, Port Elizabeth Central	Erf 816, Port Elizabeth Central.
7 Moffat Street, Port Elizabeth Central	Erf 814, Port Elizabeth Central.
38 Military Road, Port Elizabeth Central	Erf 3648, Port Elizabeth Central.
13 and 15 Military Road, Port Elizabeth Central	Erf 3798, Port Elizabeth Central.
11 Military Road, Port Elizabeth Central	Erf 3797, Port Elizabeth Central.
1 Military Road, Port Elizabeth Central	Erf 3792, Port Elizabeth Central.
22 Gerald Street, Newton Park, Port Elizabeth	Erf 1228, Port Elizabeth at Newton Park.
34 Gerald Street, Newton Park, Port Elizabeth	Erf 1208, Port Elizabeth at Newton Park.
44 Gerald Street, Newton Park, Port Elizabeth	Erf 1199, Port Elizabeth at Newton Park.
61 Gerald Street, Newton Park, Port Elizabeth	Erf 747, Port Elizabeth at Newton Park.
8 Third Avenue, Newton Park, Port Elizabeth	Erf 2171, Port Elizabeth at Newton Park.
17 Third Avenue, Newton Park, Port Elizabeth	Erf 2102, Port Elizabeth at Newton Park.
19 Third Avenue, Newton Park, Port Elizabeth	Erf 2103, Port Elizabeth at Newton Park.
28 Third Avenue, Newton Park, Port Elizabeth	Erf 1965, Port Elizabeth at Newton Park.
37 Third Avenue, Newton Park, Port Elizabeth	Erf 1834, Port Elizabeth at Newton Park.
43 and 45 Third Avenue, Newton Park, Port Elizabeth	Erf 1517, Port Elizabeth at Newton Park.
49 Third Avenue, Newton Park, Port Elizabeth	Erf 1568, Port Elizabeth at Newton Park.
51 Third Avenue, Newton Park, Port Elizabeth	Erf 1836, Port Elizabeth at Newton Park.
3 Kinnersley Street, Newton Park, Port Elizabeth	Erf 1125, Port Elizabeth at Newton Park.
13 Kinnersley Street, Newton park, Port Elizabeth	Erf 1116, Port Elizabeth at Newton Park.
14 Kinnersley Street, Newton Park, Port Elizabeth	Erf 1151, Port Elizabeth at Newton Park.
40 Kinnersley Street, Newton Park, Port Elizabeth	Erf 1184, Port Elizabeth at Newton Park.
44 Kinnersley Street, Newton Park, Port Elizabeth	Erf 1188, Port Elizabeth at Newton Park.
45 Kinnersley Street, Newton Park, Port Elizabeth	Erf 710, Port Elizabeth at Newton Park.
47 Kinnersley Street, Newton Park, Port Elizabeth	Erf 711, Port Elizabeth at Newton Park.
55 Kinnersley Street, Newton Park, Port Elizabeth	Erf 715, Port Elizabeth at Newton Park.
11 King Edward Street, Newton Park, Port Elizabeth	Erf 2168, Port Elizabeth at Newton Park.
32 King Edward Street, Newton Park, Port Elizabeth	Erf 2060, Port Elizabeth at Newton Park.
39 King Edward Street, Newton Park, Port Elizabeth	Erf 2051, Port Elizabeth at Newton Park.
46 King Edward Street, Newton Park, Port Elizabeth	Erf 153, Port Elizabeth at Newton Park.
48 King Edward Street, Newton Park, Port Elizabeth	Erf 152, Port Elizabeth at Newton Park.
49 King Edward Street, Newton Park, Port Elizabeth	Erf 94, Port Elizabeth at Newton Park.
51 King Edward Street, Newton Park, Port Elizabeth	Erf 95/96, Port Elizabeth at Newton Park.
56 King Edward Street, Newton Park, Port Elizabeth	Erf 133, Port Elizabeth at Newton Park.

**DEPARTEMENT VAN PLAASLIKE BESTUUR,
BEHUISING EN WERKE**

No. 2333 16 Oktober 1987

WET OP HUURBEHEER, 1976

**VRYSTELLING VAN SEKERE WONINGS, MOTOR-
HUISE, MOTORSTAANPLEKKE EN BEDIENDE-
KAMERS VAN HUURBEHEER**

Kragtens artikel 51 (g) van die Wet op Huurbeheer, 1976 (Wet 80 van 1976), verklaar ek, Abraham Adriaan Venter, Minister van Plaaslike Bestuur, Behuising en Werke hierby dat—

- (a) die woning genoem in Bylae A, met ingang van die datum van hierdie Kennisgewing;
- (b) die woning genoem in Bylae B, met ingang van die datum waarop 'n bestaande huurder van so 'n woning se okkupasie wettiglik beëindig word of die datum waarop sodanige huurder se maandelikse inkomste soos omskryf in Proklamasie 32 van 25 Maart 1983, soos gewysig by Proklamasie 99 van 1 Julie 1983, en Proklamasie 24 van 20 Februarie 1987, die toepaslike inkomsteperk vermeld in die Bylae by eersgenoemde Proklamasie, soos aldus gewysig, naamlik R1 250 ten opsigte van 'n huurder wat 'n gesinshoof met afhanklikes is of R750 ten opsigte van 'n enkelopende huurder sonder afhanklikes is of R750 ten opsigte van 'n enkelopende huurder sonder afhanklikes, oorskry, welke datum ook al eerste voorval, mits die betrokke huurder op die betrokke datum nie 70 jaar of ouer is nie; en
- (c) die motorhuise, motorstaanplekke en bediendekamers geleë op enige plek op grond wat deel uitmaak van grond wat geokkupeer word deur of gebruik word in verband met die wonings in paragraaf (a) en (b) hierbo bedoel, met ingang van die toepaslike datum in die betrokke paragraaf bedoel,

van huurbeheer vrygestel is, op voorwaarde dat, behoudens die bepalings van artikel 28 van genoemde Wet op Huurbeheer, 1976, gedurende 'n tydperk van drie kalendermaande vanaf die datum van vrystelling van die betrokke perseel van huurbeheer die verhuurder nie van die huurder mag vereis om die perseel te ontruim nie, en voorts dat gedurende 'n tydperk vereis om die perseel te ontruim nie, en voorts dat gedurende 'n tydperk van twee jaar vanaf die datum van vrystelling van die betrokke perseel die huurgeld ten opsigte daarvan nie met meer as 10 % per jaar verhoog mag word nie.

A. A. VENTER,
Minister van Plaaslike Bestuur, Behuising en Werke.

**DEPARTMENT OF LOCAL GOVERNMENT,
HOUSING AND WORKS**

No. 2333 16 October 1987

RENT CONTROL ACT, 1976

**EXEMPTION OF CERTAIN DWELLINGS, GARAGES,
PARKING SPACES AND SERVANT'S ROOMS FROM
RENT CONTROL**

Under section 51 (g) of the Rent Control Act, 1976 (Act 80 of 1976), I, Abraham Adriaan Venter, Minister of Local Government, Housing and Works, hereby declare that—

- (a) the dwellings mentioned in Annexure A are, as from the date of this Notice;
- (b) the dwellings mentioned in Annexure B are, as from the date on which the occupation of an existing lessee of such a dwelling is lawfully terminated or the date on which the monthly income of such lessee, as defined in Proclamation 32 of 25 March 1983, as amended by Proclamation 99 of 1 July 1983, and Proclamation 24 of 20 February 1987, exceeds the applicable income limit stipulated in the Schedule to the first-mentioned Proclamation, as so amended, namely R1 250 in respect of a lessee who is the head of a family with dependants or R750 in respect of a single lessee without dependants, whichever date occurs first, provided the lessee in question on the applicable date is not 70 years of age or older; and
- (c) the garages, parking spaces and servant's rooms situated anywhere on land which forms part of land occupied or used in connection with the dwellings referred to in paragraph (a) or (b) above, are, as from the applicable date referred to in the relevant paragraph,

exempted from rent control, on condition that, subject to the provisions of section 28 of the said Rent Control Act, 1976, during a period of three calendar months as from the date of exemption of the relevant premises from rent control, the lessor may not require the lessee to vacate the premises, and further that during a period of two years as from the date of exemption of the relevant premises the rental in respect thereof shall not be increased by more than 10 % per annum.

A. A. VENTER,
Minister of Local Government, Housing and Works.

BYLAE A

Adres van eiendom

Sherlockstraat 44, Port Elizabeth Sentraal
St Patricksweg 11, Port Elizabeth Sentraal
St Patricksweg 12, Port Elizabeth Sentraal
St Patricksweg 13a en 15a, Port Elizabeth Sentraal
St Patricksweg 46 Port Elizabeth Sentraal
St Patricksweg 48, Port Elizabeth Sentraal
St Patricksweg 52, Port Elizabeth Sentraal
St Patricksweg 78, Port Elizabeth Sentraal
St Patricksweg 90, Port Elizabeth Sentraal
St Philipsstraat 11, Port Elizabeth Sentraal

Ligging van eiendom

Erf 621, Port Elizabeth Sentraal.
Erf 716, Port Elizabeth Sentraal.
Erf 793, Port Elizabeth Sentraal.
Erf 715, Port Elizabeth Sentraal.
Erf 651, Port Elizabeth Sentraal.
Erf 650, Port Elizabeth Sentraal.
Erf 648, Port Elizabeth Sentraal.
Erf 426, Port Elizabeth Sentraal.
Erf 428, Port Elizabeth Sentraal.
Erf 876, Port Elizabeth Sentraal.

BYLAE B

Adres van eiendom

Sherlockstraat 34, Port Elizabeth Sentraal
Sherlockstraat 35, Port Elizabeth Sentraal
Sherlockstraat 36, Port Elizabeth Sentraal
Sherlockstraat 37, Port Elizabeth Sentraal

Ligging van eiendom

Erf 626, Port Elizabeth Sentraal.
Erf 4466, Port Elizabeth Sentraal.
Erf 625, Port Elizabeth Sentraal.
Erf 5026, Port Elizabeth Sentraal.

Adres van eiendom

Sherlockstraat 38, Port Elizabeth Sentraal
 Sherlockstraat 39, Port Elizabeth Sentraal
 Sherlockstraat 55, Port Elizabeth Sentraal
 Sherlockstraat 57, Port Elizabeth Sentraal
 Sherlockstraat 59, Port Elizabeth Sentraal
 Somersetstraat 1, Port Elizabeth Sentraal
 Somersetstraat 3 en 5, Port Elizabeth Sentraal
 Somersetstraat 9, 9a en 11, Port Elizabeth Sentraal
 Somersetstraat 23, Port Elizabeth Sentraal
 St Patricksweg 14b, Port Elizabeth Sentraal
 St Patricksweg 21, Port Elizabeth Sentraal
 St Patricksweg 27, Port Elizabeth Sentraal
 St Patricksweg 36, Port Elizabeth Sentraal
 St Patricksweg 40, Port Elizabeth Sentraal
 St Patricksweg 42, Port Elizabeth Sentraal
 St Patricksweg 44, Port Elizabeth Sentraal
 St Patricksweg 74, Port Elizabeth Sentraal
 St Patricksweg 80, Port Elizabeth Sentraal
 St Patricksweg 92, Port Elizabeth Sentraal
 St Patricksweg 82, Port Elizabeth Sentraal
 St Patricksweg 88, Port Elizabeth Sentraal
 St Philipsstraat 1, Port Elizabeth Sentraal
 St Philipsstraat 6, Port Elizabeth Sentraal
 St Philipsstraat 43, 45 en 45a, Port Elizabeth Sentraal
 St Philipsstraat 47, Port Elizabeth Sentraal
 St Philipsstraat 43, Port Elizabeth Sentraal
 St Philipsstraat 39, Port Elizabeth Sentraal
 St Philipsstraat 7, Port Elizabeth Sentraal
 St Philipsstraat 8, Port Elizabeth Sentraal
 St Philipsstraat 9, Port Elizabeth Sentraal
 St Philipsstraat 12, Port Elizabeth Sentraal
 St Philipsstraat 13, Port Elizabeth Sentraal
 St Philipsstraat 16, Port Elizabeth Sentraal
 St Philipsstraat 17 en 15, Port Elizabeth Sentraal
 St Philipsstraat 19, Port Elizabeth Sentraal
 St Philipsstraat 20, Port Elizabeth Sentraal
 St Philipsstraat 21, Port Elizabeth Sentraal
 St Philipsstraat 26, Port Elizabeth Sentraal
 St Philipsstraat 37, Port Elizabeth Sentraal
 St Philipsstraat 38, Port Elizabeth Sentraal
 St Philipsstraat 42, Port Elizabeth Sentraal
 St Stephensastraat 2, Port Elizabeth Sentraal
 St Stephensastraat 3, Port Elizabeth Sentraal
 St Stephensastraat 6, Port Elizabeth Sentraal
 St Stephensastraat 8, Port Elizabeth Sentraal
 St Stephensastraat 11, Port Elizabeth Sentraal
 St Stephensastraat 13, Port Elizabeth Sentraal
 St Stephensastraat 14, Port Elizabeth Sentraal
 St Stephensastraat 15 en 15a, Port Elizabeth Sentraal

Ligging van eiendom

Erf 624, Port Elizabeth Sentraal.
 Erf 425, Port Elizabeth Sentraal.
 Erf 568, Port Elizabeth Sentraal.
 Erf 567, Port Elizabeth Sentraal.
 Erf 565, Port Elizabeth Sentraal.
 Erf 285, Port Elizabeth Sentraal.
 Erf 282, Port Elizabeth Sentraal.
 Erf 283, Port Elizabeth Sentraal.
 Erf 285, Port Elizabeth Sentraal.
 Erf 781, Port Elizabeth Sentraal.
 Erf 394, Port Elizabeth Sentraal.
 Erf 396, Port Elizabeth Sentraal.
 Erf 655, Port Elizabeth Sentraal.
 Erf 654, Port Elizabeth Sentraal.
 Erf 653, Port Elizabeth Sentraal.
 Erf 652, Port Elizabeth Sentraal.
 Erf 583, Port Elizabeth Sentraal.
 Erf 581, Port Elizabeth Sentraal.
 Erf 572, Port Elizabeth Sentraal.
 Erf 580, Port Elizabeth Sentraal.
 Erf 428, Port Elizabeth Sentraal.
 Erf 880, Port Elizabeth Sentraal.
 Erf 872, Port Elizabeth Sentraal.
 Erf 503, Port Elizabeth Sentraal.
 Erf 671, Port Elizabeth Sentraal.
 Erf 503, Port Elizabeth Sentraal.
 Erf 501, Port Elizabeth Sentraal.
 Erf 481, Port Elizabeth Sentraal.
 Erf 509, Port Elizabeth Sentraal.
 Erf 483, Port Elizabeth Sentraal.
 Erf 869, Port Elizabeth Sentraal.
 Erf 485, Port Elizabeth Sentraal.
 Erf 513, Port Elizabeth Sentraal.
 Erf 478, Port Elizabeth Sentraal.
 Erf 487, Port Elizabeth Sentraal.
 Erf 867, Port Elizabeth Sentraal.
 Erf 488, Port Elizabeth Sentraal.
 Erf 864, Port Elizabeth Sentraal.
 Erf 692, Port Elizabeth Sentraal.
 Erf 655, Port Elizabeth Sentraal.
 Erf 653, Port Elizabeth Sentraal.
 Erf 411, Port Elizabeth Sentraal.
 Erf 4972, Port Elizabeth Sentraal.
 Erf 859, Port Elizabeth Sentraal.
 Erf 413, Port Elizabeth Sentraal.
 Erf 402, Port Elizabeth Sentraal.
 Erf 678, Port Elizabeth Sentraal.
 Erf 862, Port Elizabeth Sentraal.
 Erf 457, Port Elizabeth Sentraal.

ANNEXURE A

Address of premises

44 Sherlock Street, Port Elizabeth Central
 11 St Patrick Road, Port Elizabeth Central
 12 St Patrick Road, Port Elizabeth Central
 13a and 15a St Patrick Road, Port Elizabeth Central
 46 St Patrick Road, Port Elizabeth Central
 48 St Patrick Road, Port Elizabeth Central
 52 St Patrick Road, Port Elizabeth Central
 78 St Patrick Road, Port Elizabeth Central
 90 St Patrick Road, Port Elizabeth Central
 11 St Philips Street, Port Elizabeth Central

Situation of premises

Erf 621, Port Elizabeth Central.
 Erf 716, Port Elizabeth Central.
 Erf 793, Port Elizabeth Central.
 Erf 715, Port Elizabeth Central.
 Erf 651, Port Elizabeth Central.
 Erf 650, Port Elizabeth Central.
 Erf 648, Port Elizabeth Central.
 Erf 426, Port Elizabeth Central.
 Erf 428, Port Elizabeth Central.
 Erf 876, Port Elizabeth Central.

ANNEXURE B

Address of premises

34 Sherlock Street, Port Elizabeth Central
 35 Sherlock Street, Port Elizabeth Central
 36 Sherlock Street, Port Elizabeth Central
 37 Sherlock Street, Port Elizabeth Central
 38 Sherlock Street, Port Elizabeth Central
 39 Sherlock Street, Port Elizabeth Central

Situation of premises

Erf 626, Port Elizabeth Central.
 Erf 4466, Port Elizabeth Central.
 Erf 625, Port Elizabeth Central.
 Erf 5026, Port Elizabeth Central.
 Erf 624, Port Elizabeth Central.
 Erf 425, Port Elizabeth Central.

<i>Address of premises</i>	<i>Situation of premises</i>
55 Sherlock Street, Port Elizabeth Central	Erf 568, Port Elizabeth Central.
57 Sherlock Street, Port Elizabeth Central	Erf 567, Port Elizabeth Central.
59 Sherlock Street, Port Elizabeth Central	Erf 565, Port Elizabeth Central.
1 Somerset Street, Port Elizabeth Central	Erf 285, Port Elizabeth Central.
3 and 5 Somerset Street, Port Elizabeth Central	Erf 282, Port Elizabeth Central.
9, 9a and 11, Somerset Street, Port Elizabeth Central	Erf 283, Port Elizabeth Central.
23 Somerset Street, Port Elizabeth Central	Erf 285, Port Elizabeth Central.
14b St Patricks Road, Port Elizabeth Central	Erf 781, Port Elizabeth Central.
21 St Patricks Road, Port Elizabeth Central	Erf 394, Port Elizabeth Central.
27 St Patricks Road, Port Elizabeth Central	Erf 396, Port Elizabeth Central.
36 St Patricks Road, Port Elizabeth Central	Erf 655, Port Elizabeth Central.
40 St Patricks Road, Port Elizabeth Central	Erf 654, Port Elizabeth Central.
42 St Patricks Road, Port Elizabeth Central	Erf 653, Port Elizabeth Central.
44 St Patricks Road, Port Elizabeth Central	Erf 652, Port Elizabeth Central.
74 St Patricks Road, Port Elizabeth Central	Erf 583, Port Elizabeth Central.
80 St Patricks Road, Port Elizabeth Central	Erf 581, Port Elizabeth Central.
92 St Patricks Road, Port Elizabeth Central	Erf 572, Port Elizabeth Central.
82 St Patricks Road, Port Elizabeth Central	Erf 580, Port Elizabeth Central.
88 St Patricks Road, Port Elizabeth Central	Erf 428, Port Elizabeth Central.
1 St Philips Street, Port Elizabeth Central	Erf 880, Port Elizabeth Central.
6 St Philips Street, Port Elizabeth Central	Erf 872, Port Elizabeth Central.
43, 45 and 45a St Philips Street, Port Elizabeth Central	Erf 503, Port Elizabeth Central.
47 St Philips Street, Port Elizabeth Central	Erf 671, Port Elizabeth Central.
43 St Philips Street, Port Elizabeth Central	Erf 503, Port Elizabeth Central.
39 St Philips Street, Port Elizabeth Central	Erf 501, Port Elizabeth Central.
7 St Philips Street, Port Elizabeth Central	Erf 481, Port Elizabeth Central.
8 St Philips Street, Port Elizabeth Central	Erf 509, Port Elizabeth Central.
9 St Philips Street, Port Elizabeth Central	Erf 483, Port Elizabeth Central.
12 St Philips Street, Port Elizabeth Central	Erf 869, Port Elizabeth Central.
13 St Philips Street, Port Elizabeth Central	Erf 485, Port Elizabeth Central.
16 St Philips Street, Port Elizabeth Central	Erf 513, Port Elizabeth Central.
17 and 15 St Philips Street, Port Elizabeth Central	Erf 478, Port Elizabeth Central.
19 St Philips Street, Port Elizabeth Central	Erf 487, Port Elizabeth Central.
20 St Philips Street, Port Elizabeth Central	Erf 867, Port Elizabeth Central.
21 St Philips Street, Port Elizabeth Central	Erf 488, Port Elizabeth Central.
26 St Philips Street, Port Elizabeth Central	Erf 864, Port Elizabeth Central.
37 St Philips Street, Port Elizabeth Central	Erf 692, Port Elizabeth Central.
38 St Philips Street, Port Elizabeth Central	Erf 655, Port Elizabeth Central.
42 St Philips Street, Port Elizabeth Central	Erf 653, Port Elizabeth Central.
2 St Stephens Street, Port Elizabeth Central	Erf 411, Port Elizabeth Central.
3 St Stephens Street, Port Elizabeth Central	Erf 4972, Port Elizabeth Central.
6 St Stephens Street, Port Elizabeth Central	Erf 859, Port Elizabeth Central.
8 St Stephens Street, Port Elizabeth Central	Erf 413, Port Elizabeth Central.
11 St Stephens Street, Port Elizabeth Central	Erf 402, Port Elizabeth Central.
13 St Stephens Street, Port Elizabeth Central	Erf 678, Port Elizabeth Central.
14 St Stephens Street, Port Elizabeth Central	Erf 862, Port Elizabeth Central.
15 and 15a St Stephens Street, Port Elizabeth Central	Erf 457, Port Elizabeth Central.

**DEPARTEMENT VAN PLAASLIKE BESTUUR,
BEHUISING EN WERKE**

No. 2334 **16 Oktober 1987**

WET OP HUURBEHEER, 1976

**VRYSTELLING VAN SEKERE WONINGS, MOTOR-
HUISE, MOTORSTAANPLEKKE EN BEDIENDE-
KAMERS VAN HUURBEHEER**

Kragtens artikel 51 (g) van die Wet op Huurbeheer, 1976 (Wet 80 van 1976), verklaar ek, Abraham Adriaan Venter, Minister van Plaaslike Bestuur, Behuising en Werke hierby dat—

- (a) die wonings genoem in Bylae A, met ingang van die datum van hierdie Kennisgewing;
- (b) die wonings genoem in Bylae B, met ingang van die datum waarop 'n bestaande huurder van so 'n woning se okkupasie wettiglik beëindig word of die datum waarop sodanige huurder se maandelikse inkomste soos omskryf in Proklamasie 32 van 25 Maart 1983,

**DEPARTMENT OF LOCAL GOVERNMENT,
HOUSING AND WORKS**

No. 2334 **16 October 1987**

RENT CONTROL ACT, 1976

**EXEMPTION OF CERTAIN DWELLINGS, GARAGES,
PARKING SPACES AND SERVANT'S ROOMS FROM
RENT CONTROL**

Under section 51 (g) of the Rent Control Act, 1976, (Act 80 of 1976), I, Abraham Adriaan Venter, Minister of Local Government, Housing and Works, hereby declare that—

- (a) the dwellings mentioned in Annexure A are, as from the date of this Notice;
- (b) the dwellings mentioned in Annexure B are, as from the date on which the occupation of an existing lessee of such a dwelling is lawfully terminated or the date on which the monthly income of such lessee, as defined in Proclamation 32 of 25 March 1983, as

soos gewysig by Proklamasie 99 van 1 Julie 1983, en Proklamasie 24 van 20 Februarie 1987, die toepaslike inkomsteperk vermeld in die Bylae by eersgenoemde Proklamasie, soos aldus gewysig, naamlik R1 250 ten opsigte van 'n huurder wat 'n gesinshoof met afhanklikes is of R750 ten opsigte van 'n enkellopende huurder sonder afhanklikes, oorskry, welke datum ook al eerste voorval, mits die betrokke huurder op die betrokke datum nie 70 jaar of ouer is nie; en

- (c) die motorhuise, motorstaanplekke en bediendekamers geleë op enige plek op grond wat deel uitmaak van grond wat geokkupeer word deur of gebruik word in verband met die wonings in paragraaf (a) of (b) hierbo bedoel, met ingang van die toepaslike datum in die betrokke paragraaf bedoel,

van huurbeheer vrygestel is, op voorwaarde dat, behoudens die bepalinge van artikel 28 van genoemde Wet op Huurbeheer, 1976, gedurende 'n tydperk van drie kalendermaande vanaf die datum van vrystelling van die betrokke perseel van huurbeheer die verhuurder nie van die huurder mag vereis om die perseel te ontruim nie, en voorts dat gedurende 'n tydperk van twee jaar vanaf die datum van vrystelling van die betrokke perseel die huurgeld ten opsigte daarvan nie met meer as 10 % per jaar verhoog mag word nie.

A. A. VENTER
Minister van Plaaslike Bestuur, Behuising en Werke.

amended by Proclamation 99 of 1 July 1983, and Proclamation 24 of 20 February 1987, exceeds the applicable income limit stipulated in the Schedule to the first-mentioned Proclamation, as so amended, namely R1 250 in respect of a lessee who is the head of a family with dependants or R750 in respect of a single lessee without dependants, whichever date occurs first, provided the lessee in question on the applicable date is not 70 years of age or older; and

- (c) the garages, parking spaces and servant's rooms situated anywhere on land which forms part of land occupied or used in connection with the dwellings referred to in paragraph (a) or (b) above, are, as from the applicable date referred to in the relevant paragraph,

exempted from rent control, on condition that, subject to the provisions of section 28 of the said Rent Control Act, 1976, during a period of three calendar months as from the date of exemption of the relevant premises from rent control, the lessor may not require the lessee to vacate the premises, and further that during a period of two years as from the date of exemption of the relevant premises the rental in respect thereof shall not be increased by more than 10 % per annum.

A. A. VENTER,
Minister of Local Government, Housing and Works.

BYLAE A

Adres van eiendom

Hudsonstraat 50, Newton Park, Port Elizabeth.....
Havelockstraat 42, Port Elizabeth Sentraal.....
Havelockstraat 54, Port Elizabeth Sentraal.....

Ligging van eiendom

Erf 642, Port Elizabeth te Newton Park.
Erf 2761, Port Elizabeth Sentraal.
Erf 2769, Port Elizabeth Sentraal.

BYLAE B

Adres van eiendom

La Roche-rylaan 30, Humewood, Port Elizabeth.....
Cowiestraat 9, Korsten, Port Elizabeth.....
Cowiestraat 14, Korsten, Port Elizabeth.....
Hauptstraat 143, Korsten, Port Elizabeth.....
Hauptstraat 131, Korsten, Port Elizabeth.....
Hauptstraat 133, Korsten, Port Elizabeth.....
Hauptstraat 125, Korsten, Port Elizabeth.....
De Jonghstraat 4, Korsten, Port Elizabeth.....
De Jonghstraat 22, Korsten, Port Elizabeth.....
Heighbeachweg 2, Millpark, Port Elizabeth.....
Hamptonweg 16, Millpark, Port Elizabeth.....
Hamptonweg 1, Millpark, Port Elizabeth.....
Hudsonstraat 66, Newton Park, Port Elizabeth.....
Hudsonstraat 62, Newton Park, Port Elizabeth.....
Hudsonstraat 58, Newton Park, Port Elizabeth.....
Hudsonstraat 42, Newton Park, Port Elizabeth.....
Hudsonstraat 14, Newton Park, Port Elizabeth.....
Hudsonstraat 71, Newton Park, Port Elizabeth.....
Hudsonstraat 33, Newton Park, Port Elizabeth.....
Hudsonstraat 35, Newton Park, Port Elizabeth.....
Hudsonstraat 43, Newton Park, Port Elizabeth.....
Hudsonstraat 3, Newton Park, Port Elizabeth.....
Hudsonstraat 5, Newton Park, Port Elizabeth.....
Hudsonstraat 7, Newton Park, Port Elizabeth.....
Hudsonstraat 13, Newton Park, Port Elizabeth.....
Hobsonstraat 12, Perridgevale, Port Elizabeth.....
Kingstonweg 9, Perridgevale, Port Elizabeth.....
Harrisstraat 13, Port Elizabeth Sentraal.....
Harrisstraat 3, Port Elizabeth Sentraal.....
Henri Dunantstraat 1, Port Elizabeth Sentraal.....
Havelockstraat 3, Port Elizabeth Sentraal.....
Havelockstraat 5, Port Elizabeth Sentraal.....
Havelockstraat 7, Port Elizabeth Sentraal.....
Havelockstraat 24, Port Elizabeth Sentraal.....

Ligging van eiendom

Erf 232, Port Elizabeth te Humewood.
Erf 2713, Port Elizabeth te Korsten.
Erf 2721, Port Elizabeth te Korsten.
Erf 2728, Port Elizabeth te Korsten.
Erf 2736, Port Elizabeth te Korsten.
Erf 2737, Port Elizabeth te Korsten.
Erf 2760, Port Elizabeth te Korsten.
Erf 3857, Port Elizabeth te Korsten.
Erf 3871, Port Elizabeth te Korsten.
Erf 448, Port Elizabeth te Millpark.
Erf 495, Port Elizabeth te Millpark.
Erf 556, Port Elizabeth te Millpark.
Erf 634, Port Elizabeth te Newton Park.
Erf 636, Port Elizabeth te Newton Park.
Erf 638, Port Elizabeth te Newton Park.
Erf 1259, Port Elizabeth te Newton Park.
Erf 1292, Port Elizabeth te Newton Park.
Erf 1394, Port Elizabeth te Newton Park.
Erf 1644, Port Elizabeth te Newton Park.
Erf 1645, Port Elizabeth te Newton Park.
Erf 1648, Port Elizabeth te Newton Park.
Erf 1813, Port Elizabeth te Newton Park.
Erf 1814, Port Elizabeth te Newton Park.
Erf 1815, Port Elizabeth te Newton Park.
Erf 1913, Port Elizabeth te Newton Park.
Erf 1469, Port Elizabeth te Perridgevale.
Erf 1530, Port Elizabeth te Perridgevale.
Erf 9, Port Elizabeth Sentraal.
Erf 12, Port Elizabeth Sentraal.
Erf 2303, Port Elizabeth Sentraal.
Erf 2569, Port Elizabeth Sentraal.
Erf 2570, Port Elizabeth Sentraal.
Erf 2571, Port Elizabeth Sentraal.
Erf 2593, Port Elizabeth Sentraal.

<i>Adres van eiendom</i>	<i>Ligging van eiendom</i>
Havelockstraat 37, Port Elizabeth Sentraal	Erf 2618, Port Elizabeth Sentraal.
Havelockstraat 35, Port Elizabeth Sentraal	Erf 2619, Port Elizabeth Sentraal.
Havelockstraat 39, Port Elizabeth Sentraal	Erf 2624, Port Elizabeth Sentraal.
Havelockstraat 49, Port Elizabeth Sentraal	Erf 2702, Port Elizabeth Sentraal.
Havelockstraat 53a, Port Elizabeth Sentraal	Erf 2705, Port Elizabeth Sentraal.
Havelockstraat 55A, Port Elizabeth Sentraal	Erf 2708, Port Elizabeth Sentraal.
Havelockstraat 59, Port Elizabeth Sentraal	Erf 2712, Port Elizabeth Sentraal.
Havelockstraat 63, Port Elizabeth Sentraal	Erf 2715, Port Elizabeth Sentraal.
Havelockstraat 65, Port Elizabeth Sentraal	Erf 2716, Port Elizabeth Sentraal.
Havelockstraat 75, Port Elizabeth Sentraal	Erf 2730, Port Elizabeth Sentraal.
Havelockstraat 79, Port Elizabeth Sentraal	Erf 2734, Port Elizabeth Sentraal.
Havelockstraat 81, Port Elizabeth Sentraal	Erf 2735, Port Elizabeth Sentraal.
Lawrencestraat 2, Port Elizabeth Sentraal	Erf 2760, Port Elizabeth Sentraal.
Havelockstraat 66, Port Elizabeth Sentraal	Erf 2763, Port Elizabeth Sentraal.
Havelockstraat 46, Port Elizabeth Sentraal	Erf 2767, Port Elizabeth Sentraal.
Havelockstraat 60, Port Elizabeth Sentraal	Erf 2775, Port Elizabeth Sentraal.
Havelockstraat 64, Port Elizabeth Sentraal	Erf 2778, Port Elizabeth Sentraal.
Havelockstraat 52, Port Elizabeth Sentraal	Erf 2783, Port Elizabeth Sentraal.
Havelockstraat 62, Port Elizabeth Sentraal	Erf 4773, Port Elizabeth Sentraal.
Derde Laan 1, Somerstrand, Port Elizabeth	Erf 16, Port Elizabeth te Somerstrand.
Derde Laan 4, Somerstrand, Port Elizabeth	Erf 23, Port Elizabeth te Somerstrand.
Hoofweg 205, Walmer, Port Elizabeth	Erf 129, Port Elizabeth te Walmer.
Hoofweg 47, Walmer, Port Elizabeth	Erf 149, Port Elizabeth te Walmer.
Hoofweg 78, Walmer, Port Elizabeth	Erf 161, Port Elizabeth te Walmer.
Hoofweg 255, Walmer, Port Elizabeth	Erf 729, Port Elizabeth te Walmer.
Hoofweg 155, Walmer, Port Elizabeth	Erf 785, Port Elizabeth te Walmer.
Hoofweg 139, Walmer, Port Elizabeth	Erf 792, Port Elizabeth te Walmer.
Hoofweg 137, Walmer, Port Elizabeth	Erf 795, Port Elizabeth te Walmer.
Hoofweg 85, Walmer, Port Elizabeth	Erf 832, Port Elizabeth te Walmer.
Hoofweg 59, Walmer, Port Elizabeth	Erf 851, Port Elizabeth te Walmer.
Hoofweg 41, Walmer, Port Elizabeth	Erf 867, Port Elizabeth te Walmer.
Hoofweg 39, Walmer, Port Elizabeth	Erf 869, Port Elizabeth te Walmer.
Hoofweg 40, Walmer, Port Elizabeth	Erf 917, Port Elizabeth te Walmer.
Hoofweg 54, Walmer, Port Elizabeth	Erf 925, Port Elizabeth te Walmer.
Hoofweg 60, Walmer, Port Elizabeth	Erf 927, Port Elizabeth te Walmer.
Hoofweg 74, Walmer, Port Elizabeth	Erf 942, Port Elizabeth te Walmer.
Hoofweg 170, Walmer, Port Elizabeth	Erf 992, Port Elizabeth te Walmer.
Hoofweg 192, Walmer, Port Elizabeth	Erf 1010, Port Elizabeth te Walmer.
Hoofweg 218, Walmer, Port Elizabeth	Erf 1029, Port Elizabeth te Walmer.
Hoofweg 226, Walmer, Port Elizabeth	Erf 1039, Port Elizabeth te Walmer.
Hoofweg 254, Walmer, Port Elizabeth	Erf 1054, Port Elizabeth te Walmer.
Hoofweg 77, Walmer, Port Elizabeth	Erf 1581, Port Elizabeth te Walmer.
Hoofweg 6, Walmer, Port Elizabeth	Erf 2012, Port Elizabeth te Walmer.
Hoofweg 4, Walmer, Port Elizabeth	Erf 2013, Port Elizabeth te Walmer.
Hoofweg 55, Walmer, Port Elizabeth	Erf 2027, Port Elizabeth te Walmer.
Hoofweg 46, Walmer, Port Elizabeth	Erf 2046, Port Elizabeth te Walmer.
Hoofweg 49, Walmer, Port Elizabeth	Erf 2594, Port Elizabeth te Walmer.

ANNEXURE A

<i>Address of premises</i>	<i>Situation of premises</i>
50 Hudson Street, Newton Park, Port Elizabeth	Erf 642, Port Elizabeth at Newton Park.
42 Havelock Street, Port Elizabeth Central	Erf 2761, Port Elizabeth Central.
54 Havelock Street, Port Elizabeth Central	Erf 2769, Port Elizabeth Central.

ANNEXURE B

<i>Address of premises</i>	<i>Situation of premises</i>
30 La Roche Avenue, Humewood, Port Elizabeth	Erf 232, Port Elizabeth at Humewood.
9 Cowie Street, Korsten, Port Elizabeth	Erf 2713, Port Elizabeth at Korsten.
14 Cowie Street, Korsten, Port Elizabeth	Erf 2721, Port Elizabeth at Korsten.
143 Haupt Street, Korsten, Port Elizabeth	Erf 2728, Port Elizabeth at Korsten.
131 Haupt Street, Korsten, Port Elizabeth	Erf 2736, Port Elizabeth at Korsten.
133 Haupt Street, Korsten, Port Elizabeth	Erf 2737, Port Elizabeth at Korsten.
125 Haupt Street, Korsten, Port Elizabeth	Erf 2760, Port Elizabeth at Korsten.
4 De Jongh Street, Korsten, Port Elizabeth	Erf 3857, Port Elizabeth at Korsten.
22 De Jongh Street, Korsten, Port Elizabeth	Erf 3871, Port Elizabeth at Korsten.
2 Heighbeach Road, Mill Park, Port Elizabeth	Erf 448, Port Elizabeth at Mill Park.
16 Hampton Road, Mill Park, Port Elizabeth	Erf 495, Port Elizabeth at Mill Park.
1 Hampton Road, Mill Park, Port Elizabeth	Erf 556, Port Elizabeth at Mill Park.
66 Hudson Street, Newton Park, Port Elizabeth	Erf 634, Port Elizabeth at Newton Park.

<i>Address of premises</i>	<i>Situation of premises</i>
62 Hudson Street, Newton Park, Port Elizabeth	Erf 636, Port Elizabeth at Newton Park.
58 Hudson Street, Newton Park, Port Elizabeth	Erf 638, Port Elizabeth at Newton Park.
42 Hudson Street, Newton Park, Port Elizabeth	Erf 1259, Port Elizabeth at Newton Park.
14 Hudson Street, Newton Park, Port Elizabeth	Erf 1292, Port Elizabeth at Newton Park.
71 Hudson Street, Newton Park, Port Elizabeth	Erf 1394, Port Elizabeth at Newton Park.
33 Hudson Street, Newton Park, Port Elizabeth	Erf 1644, Port Elizabeth at Newton Park.
35 Hudson Street, Newton Park, Port Elizabeth	Erf 1645, Port Elizabeth at Newton Park.
43 Hudson Street, Newton Park, Port Elizabeth	Erf 1648, Port Elizabeth at Newton Park.
3 Hudson Street, Newton Park, Port Elizabeth	Erf 1813, Port Elizabeth at Newton Park.
5 Hudson Street, Newton Park, Port Elizabeth	Erf 1814, Port Elizabeth at Newton Park.
7 Hudson Street, Newton Park, Port Elizabeth	Erf 1815, Port Elizabeth at Newton Park.
13 Hudson Street, Newton Park, Port Elizabeth	Erf 1913, Port Elizabeth at Newton Park.
12 Hobson Street, Perridgevale, Port Elizabeth	Erf 1469, Port Elizabeth at Perridgevale.
9 Kingston Road, Perridgevale, Port Elizabeth	Erf 1530, Port Elizabeth at Perridgevale.
13 Harris Street, Port Elizabeth Central	Erf 9, Port Elizabeth Central.
3 Harris Street, Port Elizabeth Central	Erf 3, Port Elizabeth Central.
1 Henri Dunant Street, Port Elizabeth Central	Erf 2303, Port Elizabeth Central.
3 Havelock Street, Port Elizabeth Central	Erf 2569, Port Elizabeth Central.
5 Havelock Street, Port Elizabeth Central	Erf 2570, Port Elizabeth Central.
7 Havelock Street, Port Elizabeth Central	Erf 2571, Port Elizabeth Central.
24 Havelock Street, Port Elizabeth Central	Erf 2593, Port Elizabeth Central.
37 Havelock Street, Port Elizabeth Central	Erf 2618, Port Elizabeth Central.
35 Havelock Street, Port Elizabeth Central	Erf 2619, Port Elizabeth Central.
39 Havelock Street, Port Elizabeth Central	Erf 2624, Port Elizabeth Central.
49 Havelock Street, Port Elizabeth Central	Erf 2702, Port Elizabeth Central.
53a Havelock Street, Port Elizabeth Central	Erf 2705, Port Elizabeth Central.
55a Havelock Street, Port Elizabeth Central	Erf 2708, Port Elizabeth Central.
59 Havelock Street, Port Elizabeth Central	Erf 2712, Port Elizabeth Central.
63 Havelock Street, Port Elizabeth Central	Erf 2715, Port Elizabeth Central.
65 Havelock Street, Port Elizabeth Central	Erf 2716, Port Elizabeth Central.
75 Havelock Street, Port Elizabeth Central	Erf 2730, Port Elizabeth Central.
79 Havelock Street, Port Elizabeth Central	Erf 2734, Port Elizabeth Central.
81 Havelock Street, Port Elizabeth Central	Erf 2735, Port Elizabeth Central.
2 Lawrence Street, Port Elizabeth Central	Erf 2760, Port Elizabeth Central.
66 Havelock Street, Port Elizabeth Central	Erf 2763, Port Elizabeth Central.
46 Havelock Street, Port Elizabeth Central	Erf 2767, Port Elizabeth Central.
60 Havelock Street, Port Elizabeth Central	Erf 2775, Port Elizabeth Central.
64 Havelock Street, Port Elizabeth Central	Erf 2778, Port Elizabeth Central.
52 Havelock Street, Port Elizabeth Central	Erf 2783, Port Elizabeth Central.
62 Havelock Street, Port Elizabeth Central	Erf 4773, Port Elizabeth Central.
1 Third Avenue, Summerstrand, Port Elizabeth	Erf 16, Port Elizabeth at Summerstrand.
4 Third Avenue, Summerstrand, Port Elizabeth	Erf 23, Port Elizabeth at Summerstrand.
205 Main Road, Walmer, Port Elizabeth	Erf 129, Port Elizabeth at Walmer.
47 Main Road, Walmer, Port Elizabeth	Erf 149, Port Elizabeth at Walmer.
78 Main Road, Walmer, Port Elizabeth	Erf 161, Port Elizabeth at Walmer.
255 Main Road, Walmer, Port Elizabeth	Erf 729, Port Elizabeth at Walmer.
155 Main Road, Walmer, Port Elizabeth	Erf 785, Port Elizabeth at Walmer.
139 Main Road, Walmer, Port Elizabeth	Erf 792, Port Elizabeth at Walmer.
137 Main Road, Walmer, Port Elizabeth	Erf 795, Port Elizabeth at Walmer.
85 Main Road, Walmer, Port Elizabeth	Erf 832, Port Elizabeth at Walmer.
59 Main Road, Walmer, Port Elizabeth	Erf 851, Port Elizabeth at Walmer.
41 Main Road, Walmer, Port Elizabeth	Erf 867, Port Elizabeth at Walmer.
39 Main Road, Walmer, Port Elizabeth	Erf 869, Port Elizabeth at Walmer.
40 Main Road, Walmer, Port Elizabeth	Erf 917, Port Elizabeth at Walmer.
54 Main Road, Walmer, Port Elizabeth	Erf 925, Port Elizabeth at Walmer.
60 Main Road, Walmer, Port Elizabeth	Erf 927, Port Elizabeth at Walmer.
74 Main Road, Walmer, Port Elizabeth	Erf 942, Port Elizabeth at Walmer.
170 Main Road, Walmer, Port Elizabeth	Erf 992, Port Elizabeth at Walmer.
192 Main Road, Walmer, Port Elizabeth	Erf 1010, Port Elizabeth at Walmer.
218 Main Road, Walmer, Port Elizabeth	Erf 1029, Port Elizabeth at Walmer.
226 Main Road, Walmer, Port Elizabeth	Erf 1039, Port Elizabeth at Walmer.
254 Main Road, Walmer, Port Elizabeth	Erf 1054, Port Elizabeth at Walmer.
77 Main Road, Walmer, Port Elizabeth	Erf 1581, Port Elizabeth at Walmer.
6 Main Road, Walmer, Port Elizabeth	Erf 2012, Port Elizabeth at Walmer.
4 Main Road, Walmer, Port Elizabeth	Erf 2013, Port Elizabeth at Walmer.
55 Main Road, Walmer, Port Elizabeth	Erf 2027, Port Elizabeth at Walmer.
46 Main Road, Walmer, Port Elizabeth	Erf 2046, Port Elizabeth at Walmer.
49 Main Road, Walmer, Port Elizabeth	Erf 2594, Port Elizabeth at Walmer.

**DEPARTEMENT VAN BINNELANDSE
SAKE****No. 2279** 16 Oktober 1987**WET OP VREEMDELINGE, 1937****VANSVERANDERING.—MOONSAMY IN ABRAHAM**

Dit het die Minister van Binnelandse Sake behaag om, kragtens die bepalings van artikel 9 van die Wet op Vreemdelinge, 1937 (Wet 1 van 1937), Kisten Moonsamy sy vrou Mariam en sy kinders Aaron Kisten, Alvin Kisten en Jonathan Kisten Moonsamy, woonagtig te Ebrahimrylaan 75, Highridge, Stanger, te magtig om die van Abraham aan te neem.

No. 2280 16 Oktober 1987**WET OP VREEMDELINGE, 1937****VANSVERANDERING.—DE VOS IN MEYER**

Dit het die Minister van Binnelandse Sake behaag om, kragtens die bepalings van artikel 9 van die Wet op Vreemdelinge, 1937 (Wet 1 van 1937), Neville Trevor de Vos, woonagtig te Villa Claudia 2, Moregloedstraat, Klopper Park, Germiston, te magtig om die van Meyer aan te neem.

No. 2316 16 Oktober 1987**WET OP VREEMDELINGE, 1937****VANSVERANDERING.—HOOSEN IN DHORAT**

Dit het die Minister van Binnelandse Sake behaag om, kragtens die bepalings van artikel 9 van die Wet op Vreemdelinge, 1937 (Wet 1 van 1937), Yacoob Hoosen, sy vrou Razia Mahomed en sy kinders Zaynab Hoosen, Mubeen Hoosen en Mohamed Hoosen, woonagtig te Sitaralaan 15, Azaadville, Krugersdorp, te magtig om die van Dhorat aan te neem.

No. 2317 16 Oktober 1987**WET OP VREEMDELINGE, 1937****VANSVERANDERING.—DORASAMY IN GOVENDER**

Dit het die Minister van Binnelandse Sake behaag om, kragtens die bepalings van artikel 9 van die Wet op Vreemdelinge, 1937 (Wet 1 van 1937), Gopala Krishnan Dorasamy, sy vrou Pathmavathi en sy kinders Mark Dorasamy, Vijaylumi Govender en Asogan Govender, woonagtig te Plaas Sterkspruit, Cliffdale, te magtig om die van Govender aan te neem.

DEPARTEMENT VAN FINANSIES**No. 2274** 16 Oktober 1987**STAATSTENDERRAAD**

Kragtens die bepalings van artikel 3 van die Wet op die Staatstenderraad, 1968 (Wet 86 van 1968), het die Minister van Finansies mnr. A. M. Nolan met ingang van 1 Oktober 1987 as lid van die die Staatstenderraad heraan gestel om die Departement van Pos- en Telekommunikasiewese te verteenwoordig.

No. 2283 16 Oktober 1987

Hiermee word bekendgemaak dat die oordragboeke van ondergenoemde Plaaslike/Binnelandse Geregistreerde Effekte van 1 November 1987 tot en met 1 Desember 1987 gesluit sal wees en dat die rente betaalbaar op 1 Desember 1987 aan die effektebesitters wat op die datum van sluiting van die oordragboeke geregistreer is, betaal sal word:

Binnelandse Geregistreerde Effekte: 11,50 Persent 2001.

DEPARTMENT OF HOME AFFAIRS**No. 2279** 16 October 1987**ALIENS ACT, 1937****CHANGE OF SURNAME.—MOONSAMY TO ABRAHAM**

The Minister of Home Affairs has been pleased under the provisions of section 9 of the Aliens Act, 1937 (Act 1 of 1937), to authorise Kisten Moonsamy, his wife Mariam and his children Aaron Kisten, Alvin Kisten and Jonathan Kisten Moonsamy, residing at 75 Ebrahim Drive, Highridge, Stanger, to assume the surname of Abraham.

No. 2280 16 October 1987**ALIENS ACT, 1937****CHANGE OF SURNAME.—DE VOS TO MEYER**

The Minister of Home Affairs has been pleased under the provisions of section 9 of the Aliens Act, 1937 (Act 1 of 1937), to authorise Neville Trevor de Vos, residing at 2 Villa Claudia, Moregloed Street, Klopper Park, Germiston, to assume the surname of Meyer.

No. 2316 16 October 1987**ALIENS ACT, 1937****CHANGE OF SURNAME.—HOOSEN TO DHORAT**

The Minister of Home Affairs has been pleased under the provisions of section 9 of the Aliens Act, 1937 (Act 1 of 1937), to authorise Yacoob Hoosen, his wife Razia Mahomed and his children Zaynab Hoosen, Mubeen Hoosen and Mohamed Hoosen, residing at 15 Sitara Avenue, Azaadville, Krugersdorp, to assume the surname of Dhorat.

No. 2317 16 October 1987**ALIENS ACT, 1937****CHANGE OF SURNAME.—DORASAMY TO GOVENDER**

The Minister of Home Affairs has been pleased under the provisions of section 9 of the Aliens Act, 1937 (Act 1 of 1937), to authorise Gopala Krishnan Dorasamy, his wife Pathmavathi and his children Mark Dorasamy, Vijaylumi Govender and Asogan Govender, residing at Sterkspruit Farm, Cliffdale, to assume the surname of Govender.

DEPARTMENT OF FINANCE**No. 2274** 16 October 1987**STATE TENDER BOARD**

In terms of the provisions of Section 3 of the State Tender Board Act, 1968 (Act 86 of 1968), the Minister of Finance has reappointed Mr A. M. Nolan as a member of the State Tender Board with effect from 1 October 1987 to represent the Department of Posts and Telecommunications.

No. 2283 16 October 1987

Notice is hereby given that the transfer books of the un-mentioned Local/Internal Registered Stocks will be closed from 1 November 1987 to 1 December 1987, both days inclusive, and that the interest due on 1 December 1987, will be paid to the stockholders registered at the date of the closing of the transfer books:

Internal Registered Stock: 11,50 Per Cent 2001.

No. 2284

16 Oktober 1987

No. 2284

16 October 1987

Staat van Inkomste ingevorder gedurende die tydperk 1 April 1987 tot 31 Augustus 1987.

Statement of Revenue collected during the period 1 April 1987 to 31 August 1987.

Tesourie, Pretoria.

Treasury, Pretoria.

Inkomstehoof	Head of Revenue	Maand Augustus Month of August		Totaal 1 April tot 31 Augustus Total 1 April to 31 August	
		1987	1986	1987	1986
Staatsinkomsterekening	State Revenue Account	R	R	R	R
Binnelandse inkomste:	Inland revenue:				
Belasting op inkomste	Tax on income	2 156 092 888	1 747 382 060	7 727 995 642	7 104 181 051
Verkoopbelasting	Sales tax	813 475 226	750 074 147	4 106 354 081	3 567 914 969
Ander belasting:	Other taxes:				
Belasting op buitelandse aandeelhouders	Non-residents shareholders' tax	23 037 795	25 159 310	157 720 922	173 399 485
Rentebelasting op buitelanders	Non-residents' tax on interest	1 884 546	2 005 269	14 506 111	14 944 254
Onuitgekeerde winste	Undistributed profits	155 960	236 359	829 199	957 078
Geskenkbelasting	Donations tax	276 592	229 273	2 538 758	1 585 068
Boedelbelasting	Estate duty	16 175 979	17 054 837	66 851 591	70 920 095
Handelseffekte	Trade securities	24 755 750	9 406 291	100 669 680	40 212 049
Seëregte en gelde	Stamp duties and fees	41 704 003	26 917 066	165 270 137	119 407 332
Hereregte	Transfer duties	32 911 072	23 989 904	160 948 461	117 393 289
Diverse	Miscellaneous	—	—	—	—
Mynverburings- en eiendomsregte	Mining leases and ownership	306 463 901	297 944 837	329 058 218	346 781 025
Rente en dividende	Interest and dividends	14 892 815	29 014 286	144 259 288	144 524 198
Heffings	Levies	6 736 314	6 243 746	19 012 405	44 952 181
Terugvorderings van lenings en voorskotte	Recoveries of loans and advances	889 829	605 148	33 694 110	5 318 953
Departementele bedrywighede	Departmental activities	162 699 951	152 871 466	483 296 313	317 576 344
	R	3 602 152 621	3 089 133 999	13 513 004 916	12 070 067 371
Min: Betalings aan selfregerende nasionale state	Less: Payments to self-governing national states	40 549 000	35 539 000	202 775 000	176 635 000
Totaal: Binnelandse inkomste	Total: Inland revenue	3 561 603 621	3 053 594 999	13 310 229 916	11 893 432 371
Doeane- en aksynsregte:	Customs and excise duties:				
Doeanereg	Customs duty	131 472 896	124 707 704	642 744 597	580 993 802
Aksynsreg	Excise duty	110 466 627	111 269 216	722 865 388	663 124 701
Bobelasting	Surcharge	58 861 364	94 252 101	316 262 310	430 755 634
Diverse	Miscellaneous	11 176 038	(2 466 151)	38 068 620	33 864 069
Brandstofheffing	Fuel levy	97 839 811	—	97 839 811	—
	R	409 816 736	327 762 870	1 817 780 726	1 708 738 206
Min:	Less:				
Bedrag tot krediet van Sentrale Inkomstefonds	Amount to the credit of Central Revenue Fund	29 100 000	29 100 000	145 500 000	145 500 000
Betalings ingevolge Doeane-unie-ooreenkomste	Payments in terms of Customs Union Agreements	—	—	752 244 000	624 072 000
Totaal: Doeane- en aksynsregte	Total: Customs and excise duties	380 716 736	298 662 870	920 036 726	939 166 206
	R	3 942 320 357	3 352 257 869	14 230 266 642	12 832 598 577
Suid-Afrikaanse Ontwikkelingsrustfonds	South African Development Trust Fund	249 082	1 487 118	6 079 346	7 900 632
Fonds vir Sorghumbieravorsingsfonds	Sorghum Beer Research Fund	133 897	—	420 701	—
	R	382 979	1 487 118	6 500 047	7 900 632
	R	3 942 703 336	3 353 744 987	14 236 766 689	12 840 499 209
Inkomsterekening: Volksraad	Revenue Account: House of Assembly				
Binnelandse inkomste	Inland revenue	2 028 241	3	31 205 896	7 881 732
Inkomsterekening: Raad van Verteenwoordigers	Revenue Account: House of Representatives				
Binnelandse inkomste	Inland revenue	1 540 421	91 188	8 997 397	2 467 791
Inkomsterekening: Raad van Afgevaardigdes	Revenue Account: House of Delegates				
Binnelandse inkomste	Inland revenue	512 299	441 519	1 378 454	1 086 588
Rekening vir Provinsiale Dienste: Kaap	Account for Provincial Services: Cape				
Provinsiale inkomste	Provincial revenue	—	—	—	—
Rekening vir Provinsiale Dienste: Natal	Account for Provincial Services: Natal				
Provinsiale inkomste	Provincial revenue	—	—	—	—
Rekening vir Provinsiale Dienste: Oranje-Vrystaat	Account for Provincial Services: Orange Free State				
Provinsiale inkomste	Provincial revenue	—	—	—	—
Rekening vir Provinsiale Dienste: Transvaal	Account for Provincial Services: Transvaal				
Provinsiale inkomste	Provincial revenue	—	—	—	—
	R	4 080 961	532 710	41 581 747	11 436 111
Groototaal	Grand total	3 946 784 297	3 354 277 697	14 278 348 436	12 851 935 320
Rekonsiliasie met opgaaf gepubliseer by Goewernmentakennigewing 2017 in Staatskoerant van 18 September 1987:	Reconciliation with statement published by Government Notice 2017 in Government Gazette of 18 September 1987:				
In Transit, 31 Maart 1987	In Transit, 31 March 1987	—	—	16 751 773	—
In Transit/Te veel oorgedra, 31 Julie 1987	In Transit/Overremitted, 31 July 1987	(65 387 929)	—	—	—
In vorderings soos hierbo	Collections as above	3 946 396 368	—	14 278 348 436	—
	R	3 881 396 368	—	14 295 100 209	—
In Transit/Te veel oorgedra, 31 Augustus 1987	In Transit/Overremitted, 31 August 1987	(959 052)	—	(959 052)	—
In Transit/Inkomsterekening: Administrasies	In Transit Revenue Account: Administrations	(29 928 172)	—	(37 500 786)	—
In Skatkierekening ontvang	Received into Exchequer Account	3 850 509 144	—	14 256 640 371	—

No. 2310

16 Oktober 1987

Staat van Ontvangste in en Oordragte uit die Skatkisrekening vir die tydperk 1 April 1987 tot 30 September 1987.

Tesourie, Pretoria.

No. 2310

16 October 1987

Statement of Receipts into and Transfers from the Exchequer Account for the period 1 April 1987 to 30 September 1987.

Treasury, Pretoria.

ONTVANGSTE—RECEIPTS

Inkomstehoof	Head of Revenue	Maand September Month of September		Totaal 1 April tot 30 September Total 1 April to 30 September	
		1987	1986	1987	1986
		R	R	R	R
Skatkissaldo, 31 Maart 1987	Exchequer Balance, 31 March 1987	—	—	299 696 068	—
Skatkissaldo, 31 Augustus 1987	Exchequer Balance, 31 August 1987	1 891 063 843	—	—	—
Staatsinkomsterekening		State Revenue Account			
Binnelandse Inkomste	Inland Revenue	3 347 917 105	2 547 625 660	16 668 244 765	14 453 747 251
Doenane en Aksyns	Customs and Excise	491 959 383	314 897 657	1 419 207 438	1 257 320 671
	R	3 839 876 488	2 862 523 317	18 087 452 203	15 711 067 922
Suid-Afrikaanse Ontwikkelingsstrustfonds	South African Development Trust Fund	249 000	1 487 000	8 891 456	11 656 632
Fonds vir Sorghumbiervorsing	Sorghum Beer Research Fund	238 723	—	660 923	—
	R	487 723	1 487 000	9 552 379	11 656 632
	R	3 840 364 211	2 864 010 317	18 097 004 582	15 722 724 554
Ander Ontvangste		Other Receipts			
Skatkisbiljete	Treasury Bills	2 364 617 250	—	18 011 440 250	—
Obligasies:	Bonds:				
Onbepaalde Termyn Tesourie-obligasies	Indefinite Period Treasury Bonds	6 117 600	—	31 480 336	—
Onbepaalde Termyn Nasionale Verdedigingsobligasies	Indefinite Period National Defence Bonds	20 824 350	—	153 676 200	—
Onbepaalde Termyn Senior Burger Spaarobligasies	Indefinite Period Senior Citizens Savings Bonds	34 293 934	—	804 470 922	—
Binnelandse Geregistreerde Effekte:	Internal Registered Stock:				
10%, 1991	10%, 1991	—	—	310 000 000	—
		—	—	(25 559 000)*	—
13%, 2008	13%, 2008	—	—	1 786 950 000	—
		—	—	(283 891 000)*	—
15%, 1994	15%, 1994	50 000 000	—	500 000 000	—
14%, 1995	14%, 1995	—	—	500 000 000	—
		—	—	(18 363 000)*	—
14%, 1992	14%, 1992	—	—	250 000 000	—
13%, 2005	13%, 2005	—	—	90 500 000	—
		—	—	(13 979 000)*	—
9%, 1988	9%, 1988	—	—	350 000 000	—
		—	—	(2 155 000)*	—
11,5%, 1990	11,5%, 1990	—	—	150 000 000	—
14%, 1993	14%, 1993	—	—	250 000 000	—
		—	—	(1 419 000)*	—
9,5%, 1990	9,5%, 1990	—	—	250 000 000	—
		—	—	(9 352 000)*	—
12,75%, 1999	12,75%, 1999	—	—	657 000 000	—
		—	—	(105 348 000)*	—
12,9%, 1992	12,9%, 1992	100 000 000	—	200 000 000	—
		(557 000)*	—	(1 632 000)*	—
13%, 1996	13%, 1996	601 000 000	—	687 000 000	—
		(49 279 000)*	—	(55 776 000)*	—
14,5%, 1993	14,5%, 1993	200 000 000	—	200 000 000	—
Buitelandse Lenings en Kredite:	Foreign Loans and Credits:				
Terugstortings, 1986-87	Surrenders, 1986-87	40 320 901	—	105 705 100	—
	R	3 417 174 035	—	25 288 222 808	—
*Min Diskonto RSA Effekte	*Less Discount RSA Stocks	49 836 000	—	517 474 000	—
	R	3 367 338 035	—	24 770 748 808	—
	R	7 207 702 246	—	42 867 753 390	—
Inkomsterekening: Volksraad		Revenue Account: House of Assembly			
Binnelandse Inkomste	Inland Revenue	2 028 241	3	31 205 896	7 881 732
Oorplasing vanaf Staatsinkomsterekening	Transfer from State Revenue Account	439 500 000	340 193 000	3 017 750 000	2 438 587 000
	R	441 528 241	340 193 003	3 048 955 896	2 546 468 732
Inkomsterekening: Raad van Verteenwoordigers		Revenue Account: House of Representatives			
Binnelandse Inkomste	Inland Revenue	1 540 421	91 187	8 997 397	2 467 791
Oorplasing vanaf Staatsinkomsterekening	Transfer from State Revenue Account	180 862 000	142 000 000	1 051 145 000	814 000 000
	R	182 402 421	142 091 187	1 060 142 397	816 467 791
Inkomsterekening: Raad van Afgevaardigdes		Revenue Account: House of Delegates			
Binnelandse Inkomste	Inland Revenue	512 299	441 519	1 378 454	1 086 589
Oorplasing vanaf Staatsinkomsterekening	Transfer from State Revenue Account	57 000 000	54 985 000	365 500 000	326 027 000
Terugstortings	Surrenders	—	18 858 050	—	18 858 050
	R	57 512 299	74 284 569	366 878 454	345 971 639
Rekening vir Provinsiale Dienste: Kaap		Account for Provincial Services: Cape			
Oorplasing vanaf Staatsinkomsterekening	Transfer from State Revenue Account	203 900 000	—	1 051 543 000	—
	R	203 900 000	—	1 051 543 000	—
Rekening vir Provinsiale Dienste: Natal		Account for Provincial Services: Natal			
Oorplasing vanaf Staatsinkomsterekening	Transfer from State Revenue Account	90 000 000	—	402 000 000	—
	R	90 000 000	—	402 000 000	—

Ikomsteheof	Head of Revenue	Maand September Month of September		Totaal 1 April tot 30 September Total 1 April to 30 September	
		1987	1986	1987	1986
		R	R	R	R
Rekening vir Provinsiale Dienste: Oranje-Vrystaat	Account for Provincial Services: Orange Free State				
Oorplasing van Staatsinkomsterekening.....	Transfer from State Revenue Account	53 000 000	—	331 468 000	—
	R	53 000 000	—	331 468 000	—
Rekening vir Provinsiale Dienste: Transvaal	Account for Provincial Services: Transvaal				
Oorplasing vanaf Staatsinkomsterekening.....	Transfer from State Revenue Account	190 000 000	—	1 011 000 000	—
	R	190 000 000	—	1 011 000 000	—
	R	8 426 045 207	—	50 139 741 137	—
Totaal (insluitende Aanvangsaldo).....	Total (including Opening Balance).....	10 317 109 050	—	50 439 437 205	—

UITBETALINGS—ISSUES

Dienste	Services	Maand September Month of September		Totaal 1 April tot 30 September Total 1 April to 30 September	
		1987	1986	1987	1986
		R	R	R	R
Staatsinkomsterekening	State Revenue Account				
Begrotingsposte	Votes				
1. Staatspresident	State President	1 200 000	1 160 000	6 434 000	5 990 000
Statutêre Bedrag	Statutory Amount	12 000	17 000	72 000	121 355
2. Parlement	Parliament	2 409 000	2 556 000	13 804 000	12 542 000
Statutêre Bedrag	Statutory Amount	1 480 000	1 350 000	8 235 000	7 300 000
3. Buro vir Inligting	Bureau for Information	2 700 000	4 449 000	14 475 000	12 849 000
4. Kommissie vir Administrasie	Commission for Administration	15 047 000	37 800 000	190 147 000	157 860 000
5. Verbetering van Diensvoorwaardes	Improvement of Conditions of Service	—	—	—	—
6. Ontwikkelingsbeplanning	Development Planning	20 000 000	348 864 000	380 000 000	2 517 926 800
Statutêre Bedrag	Statutory Amount	536 900 000	—	2 796 011 000	—
7. Buitelandse Sake	Foreign Affairs	260 000 000	106 000 000	1 020 000 000	631 100 000
Statutêre Bedrag	Statutory Amount	85 000	66 000	511 000	396 000
8. Nasionale Opvoeding	National Education	11 000 000	11 500 000	66 454 000	62 469 000
9. Administrasie: Volksraad	Administration: House of Assembly	439 500 000	340 193 000	3 017 750 000	2 538 587 000
10. Ontwikkelingshulp	Development Aid	225 000 000	175 096 000	1 241 960 000	932 048 000
Statutêre Bedrag	Statutory Amount	40 144 000	32 023 000	217 987 000	192 138 000
11. Onderwys en Opleiding	Education and Training	135 000 000	93 000 000	762 000 000	562 000 000
12. Weermag	Defence	400 000 000	373 139 000	3 057 276 000	2 722 378 000
13. Mannekrag	Manpower	17 037 000	14 000 000	93 920 000	105 018 000
14. Openbare Werke en Grondsaak	Public Works and Land Affairs	104 000 000	87 000 000	539 200 000	546 000 000
15. Justisie	Justice	20 000 000	16 600 000	117 500 000	102 400 000
Statutêre Bedrag	Statutory Amount	1 400 000	980 000	7 300 000	5 930 000
16. Gevangenis	Prisons	41 903 000	35 438 000	278 450 000	232 400 000
17. Landbou-ekonomie en -bemarking	Agricultural Economics and Marketing	60 000 000	36 000 000	412 824 000	261 000 000
18. Handel en Nywerheid	Trade and Industry	75 000 000	95 000 000	547 000 000	482 153 000
19. Minerale- en Energiesake	Mineral and Energy Affairs	71 500 000	51 150 000	380 503 000	394 333 000
20. Finansies	Finance	102 778 000	108 204 000	573 277 000	533 590 880
Statutêre Bedrag	Statutory Amount	931 858 000	800 057 000	3 599 199 000	3 043 406 000
		(49 836 000)*	(53 211 000)*	(517 474 000)*	(405 110 000)*
21. Oudit	Audit	—	1 588 000	—	7 311 000
22. Binnelandse Sake	Home Affairs	10 000 000	11 146 000	1 051 145 000	814 000 000
23. Vervoer	Transport	58 500 000	63 000 000	365 500 000	326 027 000
24. Administrasie: Raad van Verteenwoordigers	Administration: House of Representatives	180 862 000	142 000 000	1 178 341 000	954 100 000
25. Administrasie: Raad van Afgevaardigdes	Administration: House of Delegates	57 000 000	54 985 000	138 000	106 500
26. Nasionale Gesondheid en Bevolkingsontwikkeling	National Health and Population Development	185 800 000	163 600 000	820 692 000	631 500 000
Statutêre Bedrag	Statutory Amount	24 000	21 000	68 000 000	93 200 000
27. Polisie	Police	108 000 000	85 000 000	153 000 000	130 900 000
28. Omgewingsake	Environment Affairs	11 000 000	15 500 000	64 599 000	60 241 260
29. Waterwese	Water Affairs	26 000 000	20 800 000	401 000 000	377 000 000
	R	4 153 139 000	3 329 282 000	23 444 704 000	19 456 321 795
*Min Diskonto R.S.A. Effekte	*Less Discount R.S.A. Stocks	49 836 000	53 211 000	517 474 000	405 110 000
	R	4 103 303 000	3 276 071 000	22 927 230 000	19 051 211 795
Staannde Toewysings	Standing Appropriations				
Suid-Afrikaanse Ontwikkelingstrustfonds	South African Development Trust Fund	249 000	1 487 000	8 891 456	11 656 632
Fonds vir Sorghumbiervorsing	Sorghum Beer Research Fund	240 221	—	660 923	—
	R	489 221	1 487 000	9 552 379	11 656 632
	R	4 103 792 221	3 277 558 000	22 936 782 379	19 062 868 427
Ander Uitbetalings	Other Issues				
Skatkisbiljette	Treasury Bills	2 410 689 000	—	16 030 784 000	—
Belastingdelgingsertifikaat	Tax Redemption Certificates	—	—	330	—
Leningsheffing	Loan Levy	103 279	—	903 369	—
Betaalmiddelste Bydrae, I.D.A.	Currency Subscription, I.D.A.	—	—	539 000	—
I.M.F.: Kompenserende Finansierings Fasiliteit	I.M.F.: Compensatory Finance Facility	—	—	187 649 588	—
I.M.F.: Valuta Aanpassing	I.M.F.: Valuation Adjustment	—	—	719	—
I.M.F.: Bystands Krediet	I.M.F.: Standby Credit	—	—	46 912 397	—
Obligasies:	Bonds:				
Onbepaalde Termyn Tesourie-obligasies	Indefinite Period Treasury Bonds	12 814 200	—	74 042 000	—
Onbepaalde Termyn Nasionale Verdedigingsobligasies	Indefinite Period National Defence Bonds	14 866 600	—	129 392 350	—
Bonusomsettingsobligasies	Bonus Conversion Bonds	2 919 080	—	9 231 835	—
Binnelandse Geregistreerde Effekte:	Internal Registered Stock:				
11%, 1998	11%, 1998	174 000	—	215 000	—
10,625%, 2000	10,625%, 2000	—	—	50 000	—
14,5%, 1987	14,5%, 1987	—	—	1 150 000 000	—
10,75%, 1999	10,75%, 1999	—	—	44 000	—
9,8%, 2001	9,8%, 2001	—	—	21 000	—
11%, 1997	11%, 1997	—	—	24 000	—
14%, 1987	14%, 1987	700 000 000	—	700 000 000	—

Dienste	Services	Maand September Month of September		Totaal 1 April tot 30 September Total 1 April to 30 September	
		1987	1986	1987	1986
		R	R	R	R
Buitelandse Lenings en Kredite:	Foreign Loans and Credits:				
1983-87	1983-87	—	—	2 374 876	—
1980-87	1980-87	—	—	52 342 319	—
1982-84	1982-84	—	—	975 916	—
1982	1982	—	—	2 116 599	—
1982-86	1982-86	—	—	106 873	—
1983-85	1983-85	—	—	2 140 110	—
1985	1985	—	—	1 360 618	—
Uitbetalings, 1986-87	Issues, 1986-87	—	—	14 607 257	—
	R	3 141 566 159	—	18 405 834 156	—
Totaal Staatsinkomsterekening	Total State Revenue Account	7 245 358 380	—	41 342 616 535	—
Inkomsterekening: Volksraad	Revenue Account: House of Assembly	439 500 000	340 193 000	3 017 750 000	2 538 587 000
Inkomsterekening: Raad van Verteenwoordigers	Revenue Account: House of Representatives	180 862 000	142 000 000	1 051 145 000	814 000 000
Uitbetalings, 1986-87	Issues, 1986-87	—	679 000	8 926 000	679 000
Inkomsterekening: Raad van Afgevaardigdes	Revenue Account: House of Delegates	57 000	54 985 000	365 500 000	326 027 000
Rekening vir Provinsiale Dienste: Kaap	Account for Provincial Services: Cape	203 900 000	—	1 051 543 000	—
Rekening vir Provinsiale Dienste: Natal	Account for Provincial Services: Natal	90 000 000	—	402 000 000	—
Rekening vir Provinsiale Dienste: Oranje-Vrystaat	Account for Provincial Services: Orange Free State	53 000 000	—	331 468 000	—
Rekening vir Provinsiale Dienste: Transvaal	Account for Provincial Services: Transvaal	190 000 000	—	1 011 000 000	—
	R	1 214 262 000	537 857 000	7 239 332 000	3 679 293 000
Totale	Totals	8 459 620 380	—	48 581 948 535	—
Skatkissaldo, 30 September 1987	Exchequer Balance, 30 September 1987	1 857 488 670	—	1 857 488 670	—
Totale	Totals	10 317 109 050	—	50 439 437 205	—

DEPARTEMENT VAN HANDEL EN NYWERHEID

No. 2286

16 Oktober 1987

WET OP STANDAARDE, 1982

VERPLIGTE SPESIFIKASIE VIR AARDLEKBEVEILIGINGSEENHEDE

Op aanbeveling van die Raad van die Suid-Afrikaanse Buro vir Standaarde en kragtens die bevoegdheid my verleen by artikel 16 (1) van die Wet op Standaarde, 1982 (Wet 30 van 1982), verklaar ek, Daniël Wynand Steyn, Minister van Ekonomiese Sake en Tegnologie, hierby die spesifikasie in die Bylae vervat tot 'n verpligte spesifikasie vir aardlekbeveiligingseenhede.

Die verpligte spesifikasie tree in werking op 'n datum twee maande na die datum van hierdie kennisgewing.

D. W. STEYN,
Minister van Ekonomiese Sake en Tegnologie.

DEPARTMENT OF TRADE AND INDUSTRY

No. 2286

16 October 1987

STANDARDS ACT, 1982

COMPULSORY SPECIFICATION FOR EARTH LEAKAGE PROTECTION UNITS

On the recommendation of the Council of the South African Bureau of Standards and under the powers vested in me by section 16 (1) of the Standards Act, 1982 (Act 30 of 1982), I, Daniël Wynand Steyn, Minister of Economic Affairs and Technology, hereby declare the specification contained in the Schedule to be a compulsory specification for earth leakage protection units.

The compulsory specification shall become operative on a date two months after the date of publication of this notice.

D. W. STEYN,
Minister of Economic Affairs and Technology.

BYLAE

VERPLIGTE SPESIFIKASIE VIR AARDLEKBEVEILIGINGSEENHEDE

1. BESTEK.

1.1 Hierdie spesifikasie dek aardlekbeveiligingseenhede (stroombrekers) vir gebruik in huishoudelike en nywerheids- of soortgelyke elektriese installasies, wat verbind is met 'n wisselstroomtoevoerbron wat by 'n frekwensie van 50 Hz werk en waarvan die nulgeleier aan die toevoerkant met die algemene aardmassa verbind is, behoudens die volgende beperkings:

- (a) Maksimum aangeslane spanning..... 500 V.
- (b) Maksimum aangeslane stroom..... 100 A.
- (c) Maksimum aangeslane aardlekuitlinkstroom..... 30 mA.
- (d) Omgewingstemperatuur..... -5 tot +40 °C.

1.2 Die aardlekbeveiligingseenhede wat deur hierdie spesifikasie gedek word, is bedoel om brand- en elektroksiegevaar wat veroorsaak word deur strome wat uit lyn- en nulgeleiers na aarde lek, te verminder.

1.3 Hierdie spesifikasie dek nie aardlekbeveiligingseenhede wat vir gebruik in uiterste werktoestande, soos deurlopende hoë atmosferiese humiditeit, atmosferiese besoedeling, meganiese vibrasie, meganiese skok en uifers hoë of lae temperature, bedoel is nie.

2. WOORDBEPALING.

2.1 Die volgende woordbepalings geld vir die doel van hierdie spesifikasie:

Aangeslane korttermynbestandheidstroom: Die stroom, deur die fabrikant toegeken, wat 'n AL-stroombreker tydens 'n gespesifiseerde kort termyn in voorgeskrewe gebruiks en gedragstoestande in die toe posisie kan dra.

Aangeslane lasstroom: Die hoogste lasstroom, deur die fabrikant toegeken, wat 'n AL-stroombreker ononderbroke teen die aangeslane spanning in gespesifiseerde toestande kan dra sonder om die gespesifiseerde temperatuurgrense te oorskry.

Aangeslane spanning: Die hoogste spanning, deur die fabrikant toegeken, waarteen 'n AL-stroombreker gebruik kan word.

Aangeslane waarde: Die syferwaarde van 'n grootheid (bv. spanning, stroom) wat in die aanslag ingesluit is en in die merke aangetoon word.

Aanneemlik: Aanneemlik vir die owerheid wat die spesifikasie administreer.

Aardfoutstroom: Die stroom wat na aarde vloei as gevolg van 'n isolasiefout.

Aardlekbeveiligingstroombreker (AL-stroombreker): 'n AL-stroombreker wat die som van 'n aardlek- en aardfoutstroom in 'n kring kan aanvoel en die kring kan onderbreek as die stroom 'n vooraf bepaalde waarde oorskry.

Aardlekstroom: Die stroom wat van lewendige dele van die installasie na aarde vloei sonder dat daar enige isolasiefout is.

Aardlekuitklinkstroom: Die waarde van die lekstroom na aarde wat sal veroorsaak dat 'n AL-stroombreker in werking tree.

a-kontak: 'n Kontrolekontak of hulpkontak wat toe is as die hoofkontakte van die meganiese skakeltoestel toe is en oop is as hulle oop is.

b-kontak: 'n Kontrolekontak of hulpkontak wat oop is as die hoofkontakte van die meganiese skakeltoestel toe is en toe is as hulle oop is.

Breekvermoë: Die hoogste waarskynlike stroom wat die AL-stroombreker volgens die fabrikant met welslae by die aangeslane spanning in voorgeskrewe gebruiks- en gedragstoestande sal breek en sluit-en-breek.

Herstelspanning: Die spanning wat oor die aansluiters van 'n pool van 'n AL-stroombreker voorkom nadat die stroom gebreek is.

Opm.: Hierdie spanning kan gedurende twee opeenvolgende tydperke oorweeg word, een waartydens oorgangspanning bestaan, gevolg deur 'n tweede waartydens slegs kragfrekwensiespanning bestaan.

Inherente terugkeertyd: Die tydsverloop tussen 'n oopmaakwerking in gespesifiseerde abnormale toestande en die geslaagde hersluiting van die stroombreker in normale toestande.

Kragfrekwensieherstelspanning: Die herstelspanning nadat die oorgangspanningsverskynsel verdwyn het.

Kruipafstand: Die kortste afstand, gemeet tussen twee geleidele, oor die oppervlak van isoleermateriaal.

Opm.: 'n Las tussen twee stukke isoleermateriaal word as deel van die oppervlak beskou.

Oorgangherstelspanning (OHS): Die herstelspanning gedurende die tydperk waarin dit wesenlik oorganklik van aard is.

Opm.:

(a) Die oorgangherstelspanning kan ossillerend of nie-ossillerend of 'n kombinasie hiervan wees, na gelang van die kring- en stroombrekereienskappe. Dit sluit die spanningsverskuiwing van die nulgeleier van 'n veelfasekring in.

(b) Tensy anders vermeld, is die oorgangherstelspanning in drie-fasekringe die spanning oor die eerste pool wat oopmaak omdat hierdie spanning gewoonlik hoër is as die wat oor elk van die ander twee pole voorkom.

Pool: 'n Geleibaan in 'n AL-stroombreker wat voorsien is van 'n stel kontakte wat die hoofstroom deur die AL-stroombreker dra, sluit en breek.

Skakelbeheerde nulgeleier: Twee kontakte in 'n geleibaan, gewoonlik by of naby aardpotensiaal, wat die aangeslane stroom van die AL-stroombreker kan dra en wat ook 'n gespesifiseerde tyd lank 'n stroom in gespesifiseerde abnormale kringtoestande (bv. dié wat tydens kortsluiting voorkom) kan dra, maar wat nie ontwerp is om strome deur die kring te sluit of te breek nie.

Soliede nulgeleier: In 'n AL-stroombreker, 'n geleibaan wat nie van 'n stel kontakte voorsien is nie en waarmee die inkomende sowel as die uitgaande nulbaan een op elke ent verbind is.

Spanning: In die geval van 'n wisselstroomkring, die waarde van die wortel van die gemiddelde kwadraat van die spanning.

Stroom: In die geval van 'n wisselstroomkring, die waarde van die wortel van die gemiddelde kwadraat van die stroom.

Stroombreker: 'n Meganiese skakeltoestel wat strome in normale kringtoestande kan sluit, dra en breek en wat ook in gespesifiseerde abnormale kringtoestande, soos dié wat tydens kortsluiting of by 'n aardfout voorkom, strome kan sluit, 'n gespesifiseerde tyd lank kan dra en kan breek.

Opm: 'n Stroombreker is gewoonlik bedoel om nie dikwels te werk nie, hoewel sekere tipes geskik is om dikwels gebruik te word.

Driepool- en nulgeleierstroombreker: 'n Stroombreker met vier pole waarvan drie van een of meer verskillende uitklinkers voorsien is, en waarin al die pole (meganies) so gekoppel is dat hulle saam werk sodat die toevoer geïsoleer word indien 'n fout in een of meer fases voorkom.

Opm: Die drie pole wat van uitklinkers voorsien is, is bedoel om in die fasegeleiers van 'n driefasige vierdraadtoevoer en die vierde pool in die nulgeleier verbind te word.

Driepool- en skakelbeheerd nulgeleier-stroombreker: 'n Driepoolstroombreker met 'n skakelbeheerde nulgeleier wat ontwerp is om saam met die hoofpole van die stroombreker te werk en om voor die poolkontakte te sluit en na die poolkontakte te breek, met die doel om die nulgeleier in 'n driefasige vierdraadtoevoer te isoleer.

Driepoolstroombreker: 'n Stroombreker met drie pole wat elk van een of meer verskillende uitklinkers voorsien is en wat (meganies) so gekoppel is dat hulle saam werk.

Opm: Hierdie toestel is bedoel vir gebruik in 'n driefase toevoer waar beheer van die drie fases gelyktydig moet wees en waar 'n fout in een of meer fases sal veroorsaak dat die toevoer geïsoleer word.

Eenpool-en nulgeleierstroombreker: 'n Stroombreker met twee pole wat meganies so gekoppel is dat hulle saam werk en waarvan slegs een van een of meer verskillende uitklinkers voorsien is.

Eenpool-en skakelbeheerd nulgeleier-stroombreker: 'n Eenpoolstroombreker met 'n skakelbeheerde nulgeleier wat ontwerp is om saam met die pool van die stroombreker te werk en om voor die poolkontakte te sluit en na die poolkontakte te breek, met die doel om die nulgeleier te isoleer.

Eenpoolstroombreker: 'n Stroombreker met een pool wat van een of meer verskillende uitklinkers voorsien is.

Tweepoolstroombreker: 'n Stroombreker met twee pole vir verbinding met die twee geleiers van 'n toevoerbron, waar elke pool voorsien is van een of meer verskillende uitklinkers en die pole (meganies) so gekoppel is dat hulle saam werk sodat die toevoer geïsoleer word indien 'n fout in enige van die pole voorkom.

Uitklinker:

Nie-vertragings(oorstroom)uitklinker: 'n Uitklinktoestel sonder enige opsetlik vertraagde werking.

Onderspanningsuitklinker: 'n Uitklinker wat 'n AL-stroombreker met of sonder vertraging laat breek wanneer die spanning oor die aansluiters van die uitklinker onder 'n vooraf bepaalde waarde val en wat die stroombreker laat sluit wanneer die spanning oor die aansluiters 'n vooraf bepaalde waarde oorskry.

Oorstroomuitklinker: 'n Uitklinker wat 'n stroombreker met of sonder vertraging laat breek wanneer die stroom in die uitklinker 'n vooraf bepaalde waarde oorskry.

Paralleluitklinker: 'n Uitklinkspoel wat van die hoofkring of van 'n afsonderlike hulptoevoer deur 'n relè, skakelaar of ander middele bekrag word.

Vertragings(oorstroom)uitklinker: 'n Uitklinktoestel met opsetlik vertraagde werking.

Uitklinking: Die oopmaak van 'n AL-stroombreker, met die hand of outomaties.

Uitklinktyd: Die tydsverloop tussen die aanlê van 'n bestendige oorstroom of aardlekstroom en die onderbreking van die kring.

Vry ruimte: Die kortste afstand, deur die lug gemeet, tussen twee geleidele.

Vry-uitklinkende AL-stroombreker: 'n AL-stroombreker waarin die outomatiese uitklinkmeganisme die kontakte van die AL-stroombreker in fouttoestande sal oopmaak, onafhanklik van die middele wat gebruik word om die kontakte te sluit, en wat sal verseker dat die kontakte nie gesluit gehou word in 'n toestand waarin uitklinking moet voorkom nie.

Waarskynlike stroom: Die stroom wat sal vloei by die sluiting van 'n kring waarin daar vir die invoeging van 'n AL-stroombreker voorsiening gemaak is, indien 'n skakel met 'n onbeduidende impedansie ipv die AL-stroombreker ingevoeg word. (In sommige kringe kan die skakel die AL-stroombreker en die verbindingsleidings van die toevoer af vervang.)

3. **ONTWERP EN KONSTRUKSIE.**
- 3.1 **STANDAARD VAN VAKMANSKAP EN AFWERKING:** Alle werk moet behoorlik uitgevoer en afgewerk wees en moet so gerangskik wees dat dit geen gevaar inhou nie.
- 3.2 **GEVORMDE HULS:** Die werkmeganisme van 'n AL-stroombreker moet omhul wees deur 'n gevormde huls wat gemaak is van nie-brandbare isoleermateriaal wat geen vlamme of gesmelte metaal deur die openinge om die werkhefboom sal deurlaat nie.
- 3.3 **BESKERMING.**
- 3.3.1 Lewendige dele van 'n AL-stroombreker wat vir oppervlakmontering bedoel is, moet deur isoleermateriaaldeksels van aanneemlike sterkte teen onopsetlike aanraking beskerm wees.
- 3.3.2 Lewendige dele aan die onderkant van 'n AL-stroombreker wat vir oppervlakmontering ontwerp is, moet—
- (a) met 'n skerm of versperring van isoleermateriaal bedek wees; of
 - (b) minstens 3 mm onder die oppervlak van die voetstuk versink wees en bedek wees met 'n waterdigte isoleerseëlmiddel wat nie tydens enige van die toetse in Afdeling ses gespesifiseer, sal vloei nie; of
 - (c) 'n minimum vry ruimte van 6 mm van die monteerooppervlak af hê en vasgeklank, gestuik of op ander aanneemlike wyse bevestig wees sodat dit nie kan losraak nie.
- 3.4 **VRY RUIMTES EN KRUIPAFSTANDE:** Alle vry ruimtes en kruipafstande moet so groot moontlik wees en om die deurlopendheid van geleidende neerslag wat moontlik kan vorm te breek, moet kruipafstande, waar moontlik, groewe bevat.
- 3.5 **MONTERING:** Elke AL-stroombreker moet minstens twee gate vir monteerdoeleindes hê of daar moet voorsiening gemaak wees vir 'n ander montermetode wat aanneemlike stabiliteit sal verseker.
- 3.6 **BEDIENINGSMETODE.**
- 3.6.1 'n AL-stroombreker moet vir sluit en oopmaak met die hand en vir outomatiese uitklinking ontwerp wees. Die meganisme moet van die vryuitklinktipe wees.
- 3.6.2 Die aktueermeganisme moet so wees dat, as 'n AL-stroombreker op normale wyse gemonteer is, die kontakte nie vanself as gevolg van faling van die meganisme kan sluit nie.
- Opn:* Daar word geag dat 'n AL-stroombreker op die normale wyse gemonteer is as dit op 'n vertikale vlak gemonteer is met die hoofas vertikaal of horisontaal.
- 3.6.3 Die uitklinking van 'n AL-stroombreker in watter toestande binne sy aanslagbestek ook al, mag nie tot gevolg hê dat die kontakte wat die kring breek, wip of 'n neiging toon om weer te sluit nie.
- 3.7 **BOOGSKERMS:** Middele moet voorsien word om te verseker dat, wanneer 'n meerpool-AL-stroombreker werk, daar geen oorvonking tussen die pole is nie.
- 3.8 **AANDUI VAN UITKLINKING:** 'n AL-stroombreker moet so ontwerp wees dat, as dit uitgeklink het, 'n duidelike aanduiding te dien effekte vir die gebruiker sigbaar is.
- 3.9 **AANSLUITERS.**
- 3.9.1 'n AL-stroombreker moet voorsien wees van geskikte aansluiters vir die verbinding van kopergeleiers van die grootte wat in kolom 2 van Tabel 1 teenoor die stroomaanslag van die AL-stroombreker aangegee word. Die aansluiters van 'n AL-stroombreker met 'n tussenstroomaanslag moet geleiers met 'n nominale dwarsnitoppervlakte gespesifiseer vir die volgende hoër stroomaanslag kan neem.

TABEL 1—BEDRADINGSAANSLUITERS (KOPERGELEIERS)

1		2
Aangeslane stroom van stroombreker, A		PVC-bedeekte kopergeleier, getal en nominale dwarsnitoppervlakte, mm ² , min
Hoogstens	10.....	2 × 1,5
	16.....	2 × 4,0
	20.....	2 × 4,0
	25.....	2 × 4,0
	31,5.....	2 × 6,0
	40.....	10,0
	50.....	16,0
	63.....	25,0
	80.....	35,0
	100.....	50,0

- 3.9.2 Aansluiters moet so ontwerp wees dat hulle nie toelaat dat die geleiers verplaas word of dat die aansluiters self verplaas word op so 'n wyse dat die werking van die AL-stroombreker of die doeltreffendheid van die isolasie nadelig beïnvloed word nie [dit wil sê die minimum voorgeskrewe waardes vir vry ruimtes en kruipafstande in 3.3.2 (b) en (c) gespesifiseer, moet in alle normale werktoestande van die AL-stroombreker gehandhaaf word].
- 3.9.3 Elke aansluiter vir die verbinding van 'n buitegeleier moet so ontwerp wees dat dit maklik toeganklik is in die bedoelde gebruikstoestande en daarbenewens moet 'n aardaansluiter (indien een aangebring is)—
- op geskikte wyse teen korrosie beskerm wees,
 - blywend en onuitwisbaar met die simbool \oplus gemerk wees, en
 - van sodanige grootte wees dat dit 'n geleier neem wat aan die bepalings vir aardkontinuiteitsgeleiers van SABS 0142 'Die bedrading van persele' voldoen.
- 3.9.4 'n Bedradingsaansluiter hoef nie sodanig te wees dat dit 'n geleier regstreeks neem nie, dit wil sê sonder dat 'n geskikte eindpunt aan die geleier aangebring word, maar indien 'n aansluiter bedoel is om 'n stringgeleier te neem, moet middele voorsien wees om te verhoed dat die geleierdrade oopsprei.
- 3.9.5 Elke bedradingsaansluiterskroef moet in metaal inskroef en 'n gladde, netjies gesnyde draad vry van brame hê. Die punt van die skroef moet so gevorm wees dat dit nie die geleier sal beskadig nie. Behalwe soos hieronder toegelaat, mag geen yster of staal vir aansluiters gebruik word nie, tensy dit aanwesig is as bestanddeel van 'n legering wat inherent korrosiebestand is.
- 3.9.6 Aansluiters van die tipe waarin die buiteverbindingsgeleiers regstreekse elektriese kontak met die pool van 'n AL-stroombreker maak en waarop daar nie staat gemaak word om die hoofstroom van die AL-stroombreker te dra nie, kan van yster of staal wees wat op aanneemlik wyse met koper, nikkell, kadmium, silwer of sink geplateer is.
- 3.10 AARDING: Daar moet voorsiening gemaak word vir die aarding van enige oop metaaldele van 'n AL-stroombreker wat lewendig kan word indien die isolasie van enige deel van die AL-stroombreker onklaar raak (kyk ook 3.9.3).

TABEL 2—GELEIERGROOTTES VIR TEMPERATUURSTYG- EN OORSTROOMUITKLINKTOETS (KOPER)

1		2
Aangeslane stroom van stroombreker, A		Nominale dwarsnoppervlakte van geleier, mm ²
Hoogstens	10	1,5
	16	2,5
	20	2,5
	25	4
	31,5	6
	40	10
	50	10
	63	16
	80	25
	100	35

4. ELEKTRIESE EN FISIESE VEREISTES.

- 4.1 AANSLAG: Die aanslag van elke AL-stroombreker moet op grond van spanning, stroom, breekvermoë of korttermynbestandheidstroom, en getal pole bepaal wees.

(a) Die aangeslane spanning mag nie 500 V oorskry nie en die aangeslane lasstroom mag nie 100 A oorskry nie.

(b) Die breekvermoë moet 2,5 kA of 20 maal die waarde van die aangeslane stroom wees, wat ook al die groote is.

(c) Die aangeslane aardlekuitklinkstroom van 'n AL-stroombreker moet 5, 10 of 30 mA, soos toepaslik,

wees behoudens 'n toleransie van $\begin{matrix} + 0 \\ -50 \end{matrix} \%$.

Opm.: Die Internasionale Elektrotegniese Kommissie beveel die waardes vir die aangeslane aardlekuitklinkstroom aan.

- 4.2 ISOLASIEWEERSTAND: Volgens 6.3 bepaal, moet die isolasieweerstand van 'n AL-stroombreker minstens 10 M Ω wees.

4.3 ONDERSPANNINGSUITKLINKER.

- 4.3.1 Indien dit vereis word, moet 'n AL-stroombreker van 'n onderspanningsuitklinker voorsien wees.

- 4.3.2 Volgens 6.4 getoets, moet 'n AL-stroombreker wat van 'n onderspanningsuitklinker voorsien is, by 'n waarde van tussen 70 % en 35 % van die aangeslane spanning van die onderspanningsuitklinker oopmaak, selfs al daal die spanning stadig (1 % per sekonde). Die onderspanningsuitklinker moet verhoed dat die stroombreker by 'n spannings van minder as 35 % van die aangeslane spanning van die onderspanningsuitklinker sluit en mag nie verhoed dat dit by 85 % of hoër van die aangeslane spanning van die onderspanningsuitklinker sluit nie.
- 4.4 PARALLELUITKLINKER.
- 4.4.1 Indien dit vereis word, moet 'n AL-stroombreker voorsien wees van 'n spanningsbeheerde paralleluitklinker met 'n spesifieke spanningsaanslag of spanningsaanslagbestek.
- 4.4.2 Volgens 6.5 getoets, moet 'n AL-stroombreker wat van 'n spanningsbeheerde paralleluitklinker voorsien is, by 70 % sowel as 120 % van die aangeslane spanning van die paralleluitklinker werk.
- 4.5 OORSTROOMUITKLINKER.
- 4.5.1 *Algemeen:*
- 4.5.1.1 Indien dit vereis word, moet 'n AL-stroombreker van 'n oorstroomuitklinker voorsien wees.
- 4.5.1.2 Die oorstroomuitklinker moet van 'n verstelbare of nie-verstelbare vertragingstipe, of 'n nie-vertragingstipe wees.
- 4.5.1.3 Die stroom-tydkenkromme van 'n AL-stroombreker moet dié wees wat die fabrikant daaraan toegeken het en wat op die AL-stroombreker aangegee is [kyk 5.1 (k)].
- 4.5.2 *Vertragingstipe:*
- 4.5.2.1 'n AL-stroombreker met 'n nie-verstelbare vertragingstipe moet die aangeslane stroom daarvan deurlopend dra sonder om uit te klink, maar moet, volgens 6.6 getoets, outomaties uitklink binne die tydperke wat in Tabel 3 teenoor die aangeslane stroom van die AL-stroombreker aangegee word.
- 4.5.2.2 'n Verstelbare vertragingstipe moet sodanig wees dat die AL-stroombreker by die maksimum instelling daarvan aan die vereistes van 4.5.2.1 sal voldoen.
- 4.5.3 *Nie-vertragingstipe:* 'n AL-stroombreker met 'n nie-vertragingstipe moet die aangeslane stroom daarvan deurlopend dra sonder om uit te klink en indien 135 % van die aangeslane stroom aangelê word, moet dit onmiddellik uitklink en moet die boog binne 0,1 sekonde uitgedoof wees.

TABEL 3—WERKING VAN OORSTROOMUITKLINKER

1	2	3	4	5	6	7
Aangeslane stroom (I), A	Uitklynktyd, maks					
	Persentasie aangeslane stroom					
	135	200	400	600	1 000	2 000
$I \leq 40$	50 min	3 min	25 s	10,0 s	3,5 s	1,0 s
$40 < I \leq 80$	100 min	4 min				
$80 < I \leq 100$	100 min	6 min	Soos deur die fabrikant aangegee.			

- 4.6 OORBELASTING: Volgens 6.7 of 6.8, soos toepaslik, getoets, mag 'n AL-stroombreker geen teken van elektriese of meganiese faling toon nie en mag daar geen smelting, oormatige verbranding of invreting by die kontakte voorkom nie.
- 4.7 TEMPERATUURSTYGING: Volgens 6.9 bepaal, mag die temperatuurstyging van die isoleermateriaal en van elke deel van 'n AL-stroombreker nie die toepaslike waarde in Tabel 4 oorskry nie.

TABEL 4—TEMPERATUURSTYGING

1	2
Dele en tipe materiaal*	Temperatuurstyging, °C, maks
(a) Bedradingsaansluiters	70
(b) Kontakte:	
Koper of koperlegering	45
silwer	†
silwer-wolfram en ander sintermetaal	‡
(c) Katoen, sy, papier en soortgelyke materiaal, nie geïmpregneer nie	65
(d) Katoen, sy, papier en soortgelyke materiaal, met hars geïmpregneer, en emalje indien dit saam met sodanige materiaal gebruik word	80
(e) Draad bedek met formaldehid-, poliviniel- of epoksihars of poliuretaan indien hulle nie saam met vesel-materiaal gebruik word nie	95

1	2
Dele en tipe materiaal*	Temperatuur- styging, °C, maks
(f) Fenolsamestelling as elektriese isolasie gebruik	80
(g) Mika, glasvesel of asbes met bindmiddel en geïmpregneer	105
(h) Onbedekte spoele	90
(i) Werkhefbome (handbedien)	25

* Ander materiaal wat nie in hierdie tabel ingesluit is nie, word aanneemlik geag indien daar bewys is dat sodanige materiaal sonder nadelige gevolge gebruik kan word by die temperature wat tydens die dienstoestand bereik word.

† Slegs beperk omdat dit noodsaaklik is dat aanliggende dele nie beskadig word nie.

‡ Moet gespesifiseer word volgens die eienskappe van die metaal wat gebruik word en word beperk omdat dit noodsaaklik is dat aanliggende dele nie beskadig word nie.

§ Tensy daar vasgestel is dat die materiaal vir gebruik by hoër temperature aanneemlik is.

4.8 **MEGANIESE STERKTE:** Volgens 6.10 getoets, mag 'n AL-stroombreker geen teken van barste of permanente vervorming toon nie.

4.9 **PRESTASIE VAN 'N AL-STROOMBREKER IN AARDFOUTTOESTANDE:** By die toets van 'n AL-stroombreker volgens 6.11, moet die eenheid uitklink, mag die kaasdoek nie aan die brand slaan nie en mag die sekering nie deurslaan nie.

Die AL-stroombreker moet binne 24 uur na die toets suksesvol teen die aangeslane aardlekuitklinkstroom kan werk.

4.10 **BREEKVERMOË (VIR 'N AL-STROOMBREKER VOORSIEN VAN 'N OORSTROOMUITKLINKER).**

4.10.1 (a) 'n AL-stroombreker moet 'n kring, ingestel vir die waarskynlike stroom met die toepaslike drywingsfaktor in Tabel 6 teenoor die breekvermoë van die AL-stroombreker aangegee, een maal kan breek en een maal kan sluit-en-breek.

(b) Die inherente terugkeertyd van 'n AL-stroombreker mag nie 15 minute oorskry nie.

4.10.2 By die toets van 'n AL-stroombreker volgens 6.12—

(a) mag dit geen teken van elektriese of meganiese faling toon nie;

(b) mag die kaasdoek wat oor die werkhefbome geplaas is, nie aan die brand slaan nie;

(c) moet die gemiddelde waarde van die kragfrekwensieherstelspanning gelyk wees aan 'n waarde wat ooreenstem met 110 % van die aangeslane werkspanning [kyk 6.12.1 (b)] wat net voordat die toetsstroom begin vloei, oor die aansluiters van 'n pool van die AL-stroombreker voorkom, en hierdie spanning moet minstens 0,1 sekonde lank volgehou word nadat die boog uitgedoof is;

OPM: Dit mag dit nodig maak dat die aangelegde spanning verhoog moet word, maar die toleransie op die waarskynlike spitsluitstroom mag nie sonder die toestemming van die fabrikant oorskry word nie.

(d) mag daar geen beskadiging plaasvind aan die isolasie van geleiers wat gebruik word om die AL-stroombreker in die kring te verbind nie;

(e) mag die sekering wat metaaldele met die nulgeleier van die WS-kragtoevoer verbind, nie deurslaan nie;

(f) moet die AL-stroombreker steeds aan die vereistes van 4.5.2 vir werking by 200 % van die aangeslane stroom of van 4.5.3, soos toepaslik, voldoen; en

(g) moet die AL-stroombreker steeds 'n toetsspanning van die grootte wat in Tabel 7 teenoor die aangeslane spanning van die AL-stroombreker aangegee word, een minuut lank sonder deurslag kan deurmaan.

4.11 **KORTTERMYNBESTANDHEIDSTROOM (VIR 'N AL-STROOMBREKER NIE VOORSIEN VAN 'N OORSTROOMUITKLINKER NIE):** Volgens 6.13 getoets, moet 'n AL-stroombreker wat nie van 'n oorstromuitklinker voorsien is nie, die toepaslike waarskynlike stroom vir die gespesifiseerde aangeslane korttermynbestandheidstroom (minstens 2,5 kA) [kyk 5.1 (j)], met die drywingsfaktor wat geld vir die breekvermoëklas van dieselfde waarskynlike stroom (kyk Tabel 6), een maal kan sluit en hoogstens 40 ms lank kan dra.

OPM: Indien dit versoek word, moet die toets gedoen word met 'n voorafgaande stroombreker of sekering in die kring. Sodanige beveiliging moet verskaf word.

4.12 **PRESTASIE VAN 'N AL-STROOMBREKER IN AARDEKTOESTANDE:** By die toets van 'n AL-stroombreker volgens 6.14, 6.15 en 6.16—

(a) moet die AL-stroombreker elke maal positief uitklink;

(b) mag die AL-stroombreker onder geen omstandighede uitklink wanneer die waarde van die aardlekstroom minder as 50 % van die aangeslane waarde is nie;

- (c) mag geen waarde vir die werkyd in die geval van 'n skielik aangelegde aardlekstroom die toepaslike waarde in Tabel 5 oorskry nie;
- (d) moet al vyf die waardes vir aardlekstroom in elke toets vir 'n geleidelik aangelegde aardlekstroom tussen $0,5 I\Delta_n$ en $I\Delta_n$ wees, waar $I\Delta_n$ die aangeslane aardlekuitklinkstroom is; en
- (e) mag geen waarde vir die werkyd wat aangeteken word terwyl die AL-stroombreker op die aangeslane aardlekstroom gesluit is, die toepaslike waarde in kolom 2 van Tabel 5 oorskry nie.

TABEL 5—MAKSIMUM WERKTYE VIR WAARDES VAN AARDLEKSTROOM

1	2	3	4
	Werkyd, s, maks		
	$I\Delta_n$	$2I\Delta_n$	0,25 A
Aangeslane aardlekuitklinkstroom (Δ_n), A			
$I\Delta_n = 0,005$	5	1	0,04
$I\Delta_n = 0,01$	5	0,5	0,04
$I\Delta_n = 0,03$	0,5	0,2	0,04

- 4.13 **TOETS- EN HERINSTELKNOPPE:** Elke AL-stroombreker moet voorsien wees van 'n toetsknop wat maklik bereik kan word wanneer die AL-stroombreker in die normale posisie gemonteer is, en wat gebruik kan word om die korrekte funksionering van die AL-stroombreker te toets. Die toetsknop moet verkieslik 'n ligte kleur hê (rooi of groen mag nie gebruik word nie). Die toets-fasiliteit moet so in die kring verbind wees dat daar seker gemaak word dat die aanvoeltoestel, die versterker en die stroombreekmeganisme almal vir faling of agteruitgang getoets word. Die toetsfasiliteit moet so ontwerp wees dat 'n stroom wat gelyk is aan 125–175 % van die aangeslane aardlekuitklinkstroom deur die aanvoeltoestel vloei wanneer die toetsknop in werking gestel word terwyl die AL-stroombreker teen die aangeslane spanning daarvan bekrag is. Indien nodig, moet 'n herinstelknop voorsien wees, maar dit mag nie die werking van die AL-stroombreker onderdruk nie. Die toets- en herinstelknoppe moet geïdentifiseer wees soos in 5.1 (d) uiteengesit.

Volgens 6.17 getoets, mag die toetsknop geen teken van meganiese faling toon nie en moet die AL-stroombreker steeds uitklink as die toetsknop in werking gestel word.

- 4.14 **DESENSITERING AS GEVOLG VAN LUSWEERSTAND VAN 'N NULGELEIER TEEN AARDFOUT:** Volgens 6.18 getoets, moet 'n AL-stroombreker uitklink voordat die aardlekstroom twee maal die aangeslane waarde oorskry.
- 4.15 **UITKLINKING AS GEVOLG VAN KAPASITIEWE STROME:** Volgens 6.19 getoets, mag 'n AL-stroombreker nie meer as vyf maal uitklink nie.
- 4.16 **NIE-BRANDBAARHEID:** Volgens 6.20 getoets, mag materiaal wat nie-brandbaar moet wees, nie vlambare dampe afgee nie.
5. **MERKE.**
- 5.1 **AL-STROOMBREKERS:** Die volgende besonderhede moet leesbaar en onuitwisbaar op òf die romp van die AL-stroombreker òf op 'n etiket (kyk 5.3) wat stewig daaraan bevestig is, soos toepaslik, aangebring wees in een of albei amptelike tale van die Republiek van Suid-Afrika (tensy daar anders vereis word):

- (a) Die aangeslane lasstroom (I_n);
- (b) die aangeslane aardlekuitklinkstroom ($I\Delta_n$);
- (c) die "AAN"- en "AF"- posisie van die AL-stroombreker, op die werkhefboom of op die huls, op een van die volgende wyses:

- (1) Die simbool | en O onderskeidelik vir die "AAN"- en "AF"- posisie of
- (2) die woorde "AAN" en "AF" ("ON" en "OFF") in albei amptelike tale;

Opm.:

- (i) Die "AAN"- of | - merk moet aandui dat die skakelaar in die boonste posisie is;
- (ii) die simbool | wat vir die "AAN"- posisie gebruik word, moet 'n regop reguit lyn wees, nie 'n 1 of I nie.
- (d) die woorde "Toets" en "Test" of die letter T op of langs die toetsknop en "Herinstel" en "Reset" langs die herinstelknop (indien daar een is);
- (e) AL-stroombrekers wat nie van 'n oorstromuitklinker voorsien is nie, moet duidelik gemerk wees: **GEEN OORLASBEVEILIGING NIE;**

Opm.: Die operateur moet bogemelde merke [(a)–(e)] duidelik kan sien wanneer die AL-stroombreker soos vir normale gebruik gemonteer is. Indien die merke op die huls of deksel van die AL-stroombreker aangebring is, moet hulle langs die werkhefboom en sigbaar wees as die hefboom in die toepaslike posisie is. Indien die merke op deksels aangebring is, moet die deksels nie-omkeerbaar wees.

- (f) die aangeslane spanning;
- (g) die fabrikant of leweransier se naam, handelsnaam of geregistreerde handelsmerk;
- (h) 'n katalogusnommer, tipenommer of enige ander identifikasiemerk wat die AL-stroombreker onderskei van enige ander tipe stroombreker wat die fabrikant bemark;
- (i) in die geval van 'n AL-stroombreker wat van 'n nulgeleier-aansluiter voorsien is, die letters L en N om die onderskeie aansluiters te identifiseer;
- (j) die aangeslane korttermyn (40-ms)-bestandheidstroom of breekvermoëklas, in kiloampère;
- (k) die stroom-tydkenkromme (hierdie merk kan 'n kodemerk wees en geld slegs vir 'n AL-stroombreker wat van 'n oorstromuitklinker voorsien is);
- (l) 'n aanneemlike identifikasiemerk vir die lyn- en lasaansluiters of, so nie, rigtingpyle wat die ingang-en uitgang- rigting van die toevoerleidings aandui;
- (m) in die geval van 'n AL-stroombreker wat nie van 'n oorstromuitklinker voorsien is nie en nie met 'n aangeslane korttermyn- bestandheidstroomwaarde gemerk is nie, merke wat aandui dat 'n alternatiewe metode van oorlasbeveiliging die AL-stroombreker in die kring moet voorafgaan.

5.2 Die toepaslike van die volgende simbole kan ook leesbaar en onuitwisbaar op die hoofdeel van die stroombreker aangebring word:

I_n = aangeslane stroom

U_n = aangeslane spanning

I_{cn} = aangeslane breekvermoëklas, bv " $I_{cn} 2,5 \text{ kA}$ "

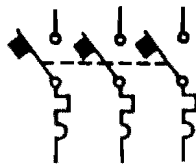

termiese, magnetiese driepool-AL-stroombreker

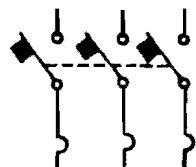

magnetiese driepool-AL-stroombreker

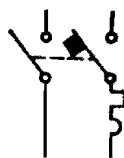

eenpool- en nulgeleier-AL-stroombreker



eenpool- en skakelbeheerdenulgeleier-AL-stroombreker

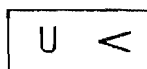

onderspanningsrelê

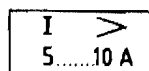

oorstroomrelê met 'n stelbestek van 5 A tot 10 A

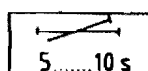

tydvertraging stelbaar van 5 sekondes tot 10 sekondes

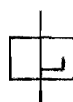

paralleluitklinker

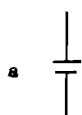

a-hulpkontak

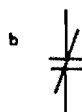

b-hulpkontak

5.3 **ETIKETTE:** Etiket (indien hulle gebruik word) moet van aanneemlike materiaal wees en by die toets daarvan volgens 6.21, moet die merke steeds leesbaar wees. In die geval van 'n kleefetiket, mag dit nie moontlik wees om die etiket in een stuk te verwyder nie.

5.4 **AARDAANSLUITERS:** Die simbool \oplus moet blywend en onuitwisbaar op elke aardaansluiter aangebring wees.

6. ONDERSOEK EN TOETSMETODES.

6.1 **ONDERSOEK:** Ondersoek elke AL-stroombreker visueel en meet dit, indien toepaslik, vir voldoening aan die toepaslike vereistes van die spesifikasie (soos in Afdeling 3, 4 en 5 aangegee) waarvoor toetse vir die beoordeling van voldoening nie in 6.3 tot en met 6.21 aangegee word nie.

6.2 TOETSE.

6.2.1 Tensy daar anders vereis word, voer die toetse op elke AL-stroombreker in sy geheel uit by 'n omgewingstemperatuur wat by 15–25 °C gehou word.

6.2.2 Toets elke eenpool- en skakelbeheerdenulgeleier-AL-stroombreker, en elke eenpool- en nulgeleier-AL-stroombreker soos 'n tweepool-AL-stroombreker.

6.2.3 Met uitsondering van die lugkernreaktor in enige fase (wat omtak moet word deur middel van 'n weerstand van sodanige waarde dat die stroom deur die resistor 0,6–0,7 % van die stroom deur die lugkernreaktor is), moet die reaktansie- of weerstandskomponente van die lasimpedansie van 'n toetskring nie parallel verbind word nie.

- 6.2.4 Gebruik, tensy daar anders gespesifiseer word, 'n wisselstroomtoevoer wat wesenlik sinusgolfvormig is en 'n frekwensie van 50 ± 2 Hz het, vir die toets. Die volgende algemene toleransies geld vir alle toetse waarby geen toleransies aangegee word nie:
- Spanning ± 5 %; stroom ± 5 %; frekwensie ± 2 Hz; tyd ± 5 %.
- 6.3 ISOLASIEWEERSTANDSTOETS: Meet die isolasieweerstand by 'n GS-spanning van 500 V op die volgende plekke:
- (a) Tussen lewendige aansluiters en enige metaaldele wat oop sal wees as die AL-stroombreker in die normale posisie gemonteer is. Voer hierdie toets uit (met alle oop metaaldele elektries met mekaar verbind en alle lewendige aansluiters elektries met mekaar verbind) met die AL-stroombreker eers in die "AAN"-posisie en dan in die "AF"-posisie;
 - (b) tussen elke inkomende en elke uitgaande aansluiter, met die AL-stroombreker in die "AF"-posisie en, in die geval van meerpoolstroombrekers, met 'n elektriese tussenverbinding tussen—
 - (1) alle inkomende aansluiters, en
 - (2) alle uitgaande aansluiters.
- Gaan na vir voldoening aan 4.2.
- 6.4 ONDERSPANNINGSUITKLINKTOETS: Verbind die onderspanningsuitklinker met 'n kragtoevoer wat teen die aangeslane spanning daarvan werk. Verminder die spanning teen 'n tempo van 1 % per sekonde totdat die AL-stroombreker uitklink, en teken die spanning op hierdie punt aan. Stel die spanning in op 34 % van die aangeslane spanning en probeer om die AL-stroombreker te sluit. Stel die spanning in op 85 % van die aangeslane spanning, sluit die AL-stroombreker en stel vas of dit by hierdie spanning gesluit bly of nie. Gaan na vir voldoening aan 4.3.2.
- 6.5 PARALLELUITKLINKTOETS: Verbind die AL-stroombreker met die kragtoevoer en stel vas of die AL-stroombreker uitklink wanneer die paralleluitklinker bekrag word by 'n toevoerspanning van—
- (a) 70 %, en
 - (b) 120 %
- van die aangeslane spanning. Gaan na vir voldoening aan 4.4.2.
- 6.6 OORSTROOMUITKLINKTOETS.
- 6.6.1 *Montering en verbindings:* Monteer die AL-stroombreker soos vir normale diens (met al die deksels in posisie) en verbind dit met die kragtoevoer deur middel van geleiers met 'n lengte van minstens 1 m en van die grootte in Tabel 2 aangegee teenoor die stroomaanslag van die AL-stroombreker.
- 6.6.2 *Prosedure:*
- (a) Gebruik enige gerieflike spanning en bepaal die stroom-tyd-kenkromme van die AL-stroombreker deur dit by 'n omgewingstemperatuur van 25 ± 5 °C teen al die volgende persentasies van die aangeslane stroom te laat werk:

135	1 000
200	2 000
400	
- Toets elke pool wat van 'n oorstroomuitklinker voorsien is afsonderlik, maar vir kalibrering teen 135 % van die aangeslane stroom moet alle pole gelyktydig en met 'n gelyke belasting getoets word. Toets twee pole of een pool en die nulgeleier om seker te maak dat die strome deur die aanvoeltoestel in ewewig is. Gaan na vir voldoening aan 4.5.1.3.
- Opm.:** Indien die kenkromme van 'n AL-stroombreker van so 'n aard is dat bogemelde punte nie 'n gladde kromme gee nie, kan bykomende punte tussenin geneem word waar dit nodig geag word.
- (b) Gaan ten slotte die stroomaanslag na deur die AL-stroombreker minstens twee uur lank teen die aangeslane stroom daarvan deur al die pole gelyktydig te laat werk.
- 6.7 OORBELASTINGTOETS VIR 'N AL-STROOBBREKER VOORSIEN VAN 'N OORSTROOMUITKLINKER.
- 6.7.1 *Toetskring:* Monteer die AL-stroombreker soos vir normale diens en verbind dit in 'n kring waarin die stroom op 600 ± 5 % van die toepaslike aangeslane waarde en die aangelegde spanning op 110 ± 5 % van die aangeslane spanning van die AL-stroombreker ingestel is. Gebruik 'n WS-kring met 'n naloopdrywingsfaktor van 0,45–0,5.

- 6.7.2 *Prosedure*: Tensy daar anders vereis word, laat die AL-stroombreker 50 maal opeenvolgend sluit en breek teen die tempo van ses werksiklusse per minuut en maak seker dat die kontakte in elke siklus hoogstens twee sekondes lank toe bly. Toets, in die geval van meerpool-AL-stroombrekers, al die pole wat bedoel is om stroom te onderbreek gelyktydig, terwyl elke pool die stroom dra wat hierbo gespesifiseer word. Voer die toets uit soos hierbo beskryf in die geval van 'n AL-stroombreker sonder 'n oorstroomuitklinker maar met 'n paralleluitklinker, maar bekrag die uitklinker só (deur 'n spanning gelyk aan die aangeslane spanning van die uitklinker aan te lê) dat die stroombreker 20–40 millisekondes nadat dit gesluit is, oopmaak. Gaan na vir voldoening aan 4.6.
- 6.8 OORBELASTINGTOETS VIR 'N AL-STROOMBREKER NIE VOORSIEN VAN 'N OORSTROOMUITKLINKER NIE.
- 6.8.1 *Toetskring*: Monteer die AL-stroombreker soos vir normale diens en verbind dit in 'n kring waarin die stroom op 150 % van die toepaslike aangeslane waarde en 'n drywingsfaktor van 0,95 ingestel is en die aangelegde spanning op 110 ± 5 % van die aangeslane spanning van die AL-stroombreker ingestel is.
- 6.8.2 *Prosedure*: Maak die AL-stroombreker vyf maal na mekaar toe en oop en maak seker dat die kontakte hoogstens twee sekondes lank in elke siklus toe bly. Toets, in die geval van meerpool-AL-stroombrekers, alle pole wat bedoel is om stroom te onderbreek gelyktydig, terwyl elke pool die stroom dra wat hierbo gespesifiseer word. Gaan na vir voldoening aan 4.6.
- 6.9 TEMPERATUURSTYGTETOETS: Monteer die AL-stroombreker soos vir normale diens (met al die deksels in posisie) op 'n plek waar daar geen trek is nie en waar die omgewingslugtemperatuur 25 ± 5 °C is.

Gebruik geleiers met 'n lengte van minstens 1 m elk en van die grootte wat in tabel 2 teenoor die stroomaanslag van die AL-stroombreker aangegee word, en verbind die AL-stroombreker met die kragtoevoer. Stuur die aangeslane stroom twee uur lank, of totdat termiese ewewig bereik is, deur die AL-stroombreker. Meet dan die toepaslike temperatuur (kyk Tabel 4) deur middel van termokoppels of volgens enige ander aanneemlike metode op die plekke waar daar geoordeel word dat die temperatuur die hoogste is. Gaan na vir voldoening aan 4.7.

6.10 TOETS VIR MEGANIESE STERKTE.

6.10.1 *Apparaat*:

(a) 'n *Meganiesesterktoets-apparaat* soos in Fig. 1 aangetoon. Die metaalsilinder A het 'n massa van 250 g en 'n buitediameter van 25 mm en pas los oor die leistung B. Die leistung is nie vas aan die raam van die toetsapparaat nie en kan maklik op- en afgeskuif word. 'n Hardeveselwaster C met 'n diameter van 25 mm en 'n dikte van 12,5 mm is aan die onderent van die leistung bevestig.

(b) 'n *Reghoekige loofhoutblok D* wat op die basis van die toetsapparaat pas.

6.10.2 *Eksemplaar*: Gebruik een AL-stroombreker uit die monster.

6.10.3 *Prosedure*:

(a) Plaas die loofhoutblok op die basis van die toetsapparaat en hou die eksemplaar styf op die blok vas of monteer dit op 'n ander wyse daarop sodat die monteervlak daarvan na onder wys (dws met die werkhefboom bo).

(b) Lig die leistung en beweeg die blok so dat, wanneer die leistung laat sak word, die veselwaster op die oppervlak van die eksemplaar rus. Laat die leistung sak, lig die metaalsilinder tot 'n hoogte van 250 mm bo die veselwaster en laat die silinder op die veselwaster val.

(c) Herhaal die valprosedure twee maal en maak seker dat die werkhefboom aan een val onderwerp word terwyl dit in die AF-posisie is.

(d) Draai die eksemplaar so dat dit op sy sykant op die blok lê.

Volg die prosedure in (b) hierbo beskryf en onderwerp die eksemplaar aan drie valle, twee na willekeur (maar nie op 'n rand van die eksemplaar nie) en een ongeveer in die middel van die aansluiterskut.

(e) Draai die eksemplaar op die ander sy en herhaal die prosedure in (d) hierbo.

(f) Ondersoek die eksemplaar nadat dit aan nege valle onderwerp is, vir voldoening aan die vereistes van 4.8.

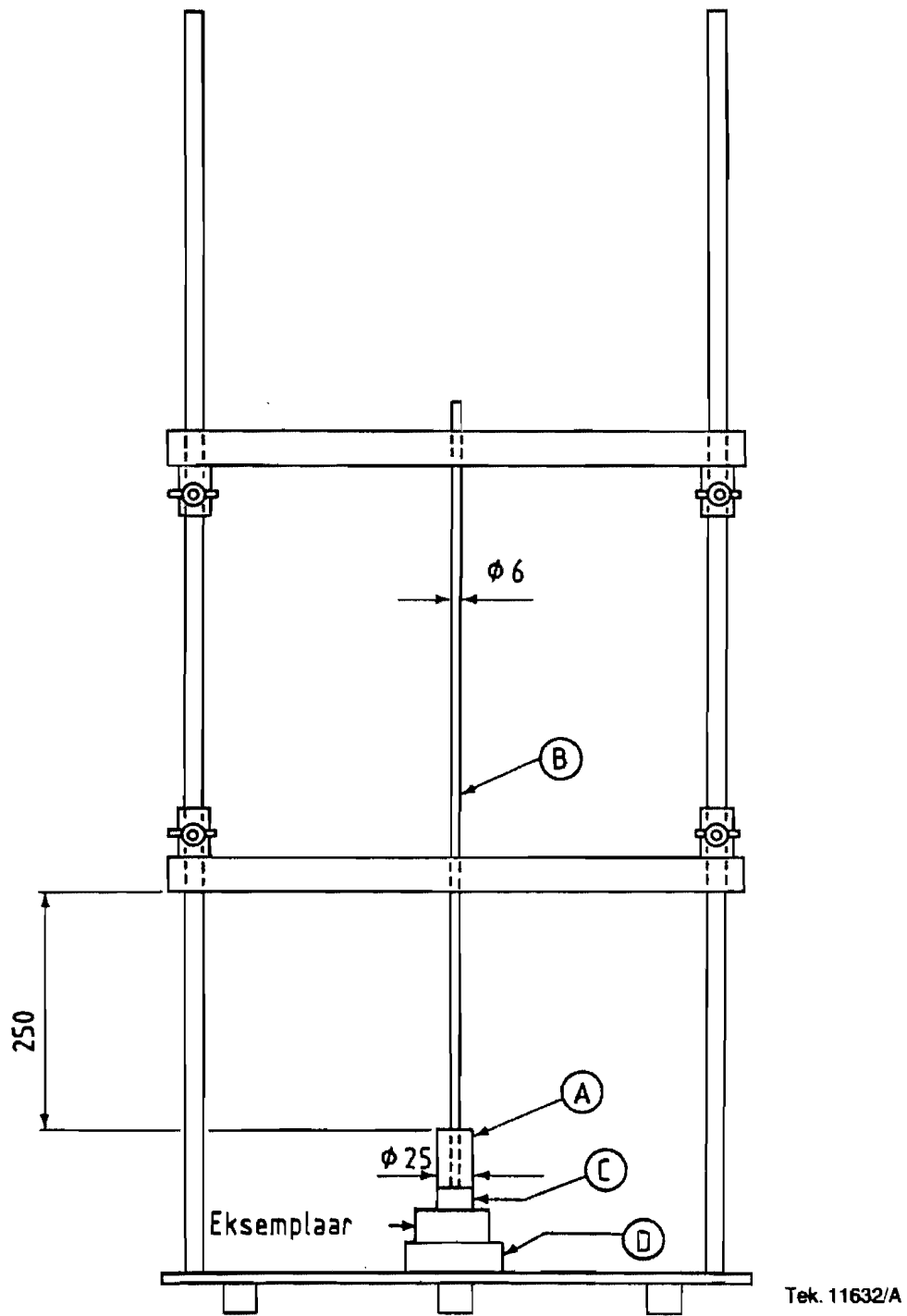

Afmetings in millimeter

Fig. 1—Apparaat vir die Toets vir Meganiese Sterkte

- 6.11 **TOETS VIR PRESTASIE VAN 'N AL-STROOMBREKER IN AARDFOUTTOESTANDE:** Verbind 'n 1-A-sekering tussen die gearde geleier van die toevoerkring en enige metaaldele wat oop sal wees as die AL-stroombreker in die normale posisie gemonteer is. Verbind alle oop metaaldele elektries met mekaar. Verbind die AL-stroombreker met 'n toevoerbron met 'n oopkringspanning van $100 \pm 5\%$ van die aangeslane spanning.

Stel die impedansie van die las sodat 'n waarskynlike aardfoutstroom van 500 A by 'n drywingsfaktor van 0,45–0,50 voorsien word. Bedek die deel van die oppervlak van die AL-stroombreker wat die werkhefboom bevat, met skoon, droë kaasdoek wat aan die vereistes vir graad 1-kaasdoek van SABS 446 'Verbandgaas (stof en deppers) en kaasdoek' voldoen. Maak seker dat geknipte of geskeurde rande van die kaasdoek nie regstreeks blootgestel is aan die boogopening waardeer vlamme uitgelaat kan word nie. Lê die aardfoutstroom een maal met behulp van 'n afsonderlike skakelaar in die toevoerkring aan en een maal met behulp van die AL-stroombrekerskakelaar, met die afsonderlike skakelaar toe (d.w.s maak die AL-stroombrekerskakelaar op die fout toe). Toets slegs een pool in die geval van 'n driefase-AL-stroombreker. Gaan na vir voldoening aan 4.9.

Ondersoek die AL-stroombreker onmiddellik na die toets vir prestasie in aardlektoestande by kamertemperatuur deur die aardlekstroom geleidelik aan te lê (kyk 6.14.3). Herhaal die aardlektoets (soos in 6.14.3) na 24 uur indien die eenheid nie aan die vereiste van 4.12 (d) voldoen nie.

- 6.12 **BREEKVERMOËTOETS (VIR 'N AL-STROOMBREKER VOORSIEN VAN 'N OORSTROOMUITKLINKER).**

6.12.1 *Kragtoevoer:*

(a) *Wisselstroom:* 'n Bron wat $100 \pm 5\%$ van die toepaslike waarskynlike stroom by die ooreenstemmende naloopdrywingsfaktor soos aangegee, kan verskaf. Enige stroombegrensimpedansie wat gebruik word, word tussen die AL-stroombreker en die kragtoevoer geplaas.

(b) *Spanning:* Die spanning van die toetskring onmiddellik voordat die toetsstroom begin vloei, moet minstens 105% en hoogstens 115% van die aangeslane spanning van die AL-stroombreker wees.

- 6.12.2 *Montering:* Monteer die AL-stroombreker soos vir normale diens en verbind dit in die toetskring met geleiers met 'n lengte (aan die belastingkant sowel as aan die lynkant) van minstens 0,5–0,75 m elk en van die grootte in Tabel 2 aangegee teenoor die stroomaanslag van die AL-stroombreker.

- 6.12.3 *Aarding van metaaldele:* Indien die AL-stroombreker enige oop metaaldele bevat of indien dit bedoel is om op 'n metaalplaat of -steunstuk gemonteer te word, verbind al sodanige metaaldele (deur 'n sekering van vertinde koperdraad met 'n nominale diameter van 0,125 mm en 'n lengte van 75–100 mm) met die nul-geleierdraad.

- 6.12.4 *Kaasdoek:* Bedek dié deel van die oppervlak van die AL-stroombreker wat die werkhefboom bevat, met skoon, droë kaasdoek wat aan die vereistes vir graad 1-kaasdoek van SABS 446 'Verbandgaas (stof en deppers) en kaasdoek' voldoen. Maak seker dat geknipte of geskeurde rande van die kaasdoek nie regstreeks blootgestel is aan die boogopening waardeer vlamme uitgelaat kan word nie.

6.12.5 *Toetskring:*

(a) *Tweepool-, eenpool- en nulgeleier-, en eenpool- en skakelbeheerdenuleleier-stroombrekers:* Gebruik die kring soos in Fig. 4 of Fig. 5 gespesifiseer.

(b) *Driepool- of driepool- en nulgeleierstroombrekers:* Gebruik die kring soos in Fig. 6 gespesifiseer.

(c) *Weerstand van spanningsmeetkring:* Die waarde van die weerstand van die spanningsmeetkring wat oor die aansluiters van 'n pool van 'n AL-stroombreker verbind is, moet minstens 100 Ω per volt van die kragfrekwensieherstelspanning wees.

6.12.6 *Prosedure:*

(a) Met die toetskring ingestel op die toepaslike spanningswaarde, waarskynlike stroom en drywingsfaktor in tabel 6 aangegee, onderwerp die AL-stroombreker aan 'n breektoets deur gebruik te maak van punt-op-golfskakeling om die grootste moontlike oorgangstroom te verkry. Hou die herstelspanning minstens 0,1 sekonde lank vol nadat die boog uitgedoof is. Onderwerp die AL-stroombreker na 'n tydverloop van minstens twee minute en hoogstens 15 minute (die inherente terugkeertyd) aan 'n sluit-en-breektoets en hou die herstelspanning minstens 0,1 sekonde lank vol nadat die boog uitgedoof is. Teken die amplitudes sowel as die duur van die spanning en stroom tydens albei toetse aan d.m.v. 'n ossillograaf of op ander aanneemlike wyse.

TABEL 6—WAARDES VAN WAARSKYNLIKE STROOM EN DRYWINGSFAKTOR VIR BREEKVERMOËTOETS

1	2	3
Breekvermoëklas	Waarskynlike stroom, simmetriese WGK, A	Drywingsfaktor, naloop
SABS 2,5 kA.....	2 500 WS	0,45–0,5
SABS 5 kA.....	5 000 WS	0,45–0,5
SABS 7,5 kA.....	7 500 WS	0,45–0,5
SABS 10 kA.....	10 000 WS	0,45–0,5
SABS 12,5 kA.....	12 500 WS	0,25–0,3
SABS 15 kA.....	15 000 WS	0,25–0,3
SABS 20 kA.....	20 000 WS	0,25–0,3
SABS 25 kA.....	25 000 WS	0,15–0,2

(b) Gaan die AL-stroombreker na afloop van die breek- en die sluit-en-breekttoets na vir voldoening aan die vereistes van 4.10.2 (a) (b), (d) en (e).

(c) Bepaal die kragfrekwensieherstelspanning volgens 6.12.7 hieronder aan die hand van die ossillogramme en gaan na vir voldoening aan die vereistes van 4.10.2 (c).

(d) Toets die oorstroomuitklinker (indien daar een is) van die AL-stroombreker volgens 6.6.2 by 135 % of 200 % van die aangeslane stroom, soos toepaslik, en gaan na vir voldoening aan 4.10.2 (f).

(e) Lê ten slotte 'n wisselspanning, van die toepaslike waarde in Tabel 7 en naastenby sinusgolvormig, aan tussen die dele in onderafdeling 6.3 aangegee.

Begin die toets teen 'n spanning van hoogstens een derde van die toepaslike toetsspanning en verhoog die spanning so vinnig as wat die meetinstrument die werklike waarde daarvan kan registreer, tot die volle toetswaarde. Hou die volle toetsspanning een minuut lank vol en verminder dit dan vinnig tot hoogstens een derde van hierdie waarde voordat dit afgeskakel word. Gaan na vir voldoening aan die vereistes van 4.10.2 (g).

TABEL 7—TOETSSPANNING

1	2
Aangeslane spanning, V, van AL-stroombreker	Toetsspanning, V (WGK)
Hoogstens 250.....	1 500
Bo 250 maar hoogstens 500.....	2 000

6.12.7 Vertolking van ossillogramme:

(a) *Bepaling van aangelegde spanning en kragfrekwensieherstelspanning:* Bepaal die aangelegde spanning en die kragfrekwensieherstelspanning aan die hand van die ossillogramme wat tydens die kalibrering van die kring, die breekttoets en die sluit-en-breekttoets verkry is, deur 'n raming van hierdie spannings te doen volgens die voorbeelde wat in Fig. 2 aangetoon word. (Fig 2 het op die sluit-en-breekttoets betrekking.)

Meet die kragfrekwensieherstelspanning gedurende die eerste halfsikus (sonder oorgangsverskynsels) nadat die boog uitgedoof is, asook gedurende die volgende vyf opeenvolgende spitse. Neem die som van hierdie ses spitse gedeel deur $6\sqrt{2}$ as die WGK-kragfrekwensieherstelspanning vir elke fase soos in Fig. 2 (b) en (c) aangetoon en gaan na vir voldoening aan die vereistes van 4.10.2 (c).

Opm.: Die aandag word daarop gevestig dat, vanweë die invloed van—

- (1) korttermynvariasies in die isolasieweerstand van 'n stroombreker,
- (2) korttermynvariasies in die isolasieweerstand van booggapings, of
- (3) die weerstand in herstelspanningsmeetkringe, of enige kombinasie hiervan, daar by sekere tipes driepoolstroombrekers 'n neiging bestaan vir die kragfrekwensieherstelspanning oor elke pool van die stroombreker om korttermynvariasies in amplitude te ondergaan, wat laer daal as 105 % en hoër styg as 115 % van die aangeslane spanning van die stroombreker. By ander tipes driepoolstroombrekers is onreëlmatige korttermynvariasies in die kragfrekwensieherstelspanning waargeneem, waartydens die amplitude van ongeveer nulwaarde tot volle herstelspanning oor een pool kan wissel, terwyl die herstelspanning oor die ander twee pole korttermynvariasies in amplitude toon wat kan wissel van 'n waarde bo tot 'n waarde onder die gespesifiseerde grense. Indien daar twyfel bestaan oor voldoening van die stroombreker aan die vereistes vir kragfrekwensieherstelspanning, neem drie bykomende stroombrekers en onderwerp hulle aan die breek- en sluit-en-breek-toets volgens die prosedure in 6.12.6 hierbo, maar met die nulgeleier van die toevoerbron met die gemeenskaplike aardverbinding (punt F in Fig. 6) verbind.

(b) *Bepaling van die waarskynlike breekstroom*: Bepaal die waarde van die waarskynlike breekstroom deur die stroomspoor wat tydens die kalibrering van die kring verkry is [kyk fig. 2 (a)], te vergelyk met dié wat tydens die breektoets (die ossillogram hiervan word nie in Fig. 2 aangetoon nie) of tydens die sluit-en-breektoets [kyk Fig. 2 (b)] verkry is. Neem die waarskynlike breekstroom in elke fase as die waarde van die WGK-kragfrekwensiekomponent van die kalibreeerstroom wat met die oomblik van skeiding van die boogkontakte ooreenstem (waardes wat met A_1 of A_2 in Fig. 2 (a) ooreenstem). Maak seker dat die waarskynlike stroom in enige fase nie met meer as 10 % van die gemiddelde waarde verskil nie.

(c) *Bepaling van die waarskynlike spitsluitstroom*: Bepaal die spitsluitstroom aan die hand van die kalibree-rossillogram en neem die waarde daarvan as gelyk aan A_3 [kyk Fig. 2 (a)]. In dié geval van 'n driefasetoets, neem die hoogste van die A_3 -waardes wat dmv. die ossillogram verkry is.

Opm.: Die aandag word daarop gevestig dat, in die geval van toetse op eenpoolstroombrekers, die waarskynlike spitsluitstroom wat aan die hand van die kalibree-rossillogram bepaal is, kan verskil van die waarde van die waarskynlike spitsluitstroom wat in die toets verkry is, na gelang van die oomblik waarop die stroom gesluit word.

6.13 TOETS VIR KORTTERMYNBESTANDHEIDSTROOM (VIR 'N AL-STROOMBREKER NIE VOORSIEN VAN 'N OORSTROOMUITKLINKER NIE): Gebruik die breekvermoëtoetskring in 6.12 aangegee.

6.14 TOETS VIR PRESTASIE VAN 'N AL-STROOMBREKER IN AARDLEKTOESTANDE BY KAMERTEMPERATUUR (15–25 °C).

6.14.1 *Kondisionering*: Kondisioneer die AL-stroombreker wat getoets word, minstens ses uur lank by die gespesifiseerde omgewingstemperatuur (kyk 6.2.1) en hou hierdie omgewingstemperatuur tydens die toets vol. Moenie die AL-stroombreker tydens kondisionering bekrag teen.

6.14.2 *Aardlekstrome wat skielik aangelê word*: Met die AL-stroombreker bekrag teen

(a) lae spanning (70 % van die aangeslane spanning of 70 % van die laagste spanning van die aangeslane spanningsbestek, soos toepaslik), en

(b) hoë spanning (110 % van die aangeslane spanning of 110 % van die hoogste spanning van die aangeslane spanningsbestek, soos toepaslik),

en sonder om 'n lasstroom deur die AL-stroombreker te stuur (behalwe dat, ten einde die toetsprosedure te vergemaklik, die kontakte van die AL-stroombreker verbind kan word met 'n kring wat 'n meetinrigting soos 'n katodestraalossillograaf, 'n elektromagnetiese ossillograaf, 'n syferteller of 'n aanwysmillivoltmeter bevat, en indien sodanige prosedure gevolg word, kan 'n stroom van hoogstens 50 % van die aangeslane lasstroom van die AL-stroombreker deur die AL-stroombreker gestuur word) lê skielik, om die beurt, teen elk van die bekragspannings die toepaslike lekstrome aan wat in Tabel 5 gespesifiseer word en teken die tydsverloop aan tussen die oomblik waarop die stroom begin vloei en die oomblik waarop die kontakte van die AL-stroombreker begin oopgaan.

Voer die toets in die geval van 'n driefase-AL-stroombreker uit deur die lekstroom na aarde om die beurt op elke stroombaan aan te lê en teken die resultate aan. Let op vir watter baan die hoogste uitklinkstroom verkry word.

Meet die werktyd vyf maal vir elke waarde van die aardlekstroom en gaan na vir voldoening aan 4.12 (c).

6.14.3 *Aardlekstrome wat geleidelik aangelê word*: Met die AL-stroombreker soos in 6.14.2 (a) en (b) bekrag, begin met 'n stroom van hoogstens $0,2 I_{\Delta_0}$ en stuur 'n lekstroom na aarde deur die AL-stroombreker. Verhoog die stroom geleidelik en probeer om binne 30 sekondes 'n aardlekstroom gelyk aan I_{Δ_0} te bereik.

Hou die stroom langer by hierdie waarde as die tydperk wat in kolom 2 van Tabel 5 teenoor die aangeslane aardlekuitklinkstroom gespesifiseer is. Voer die toets in die geval van 'n driefase-AL-stroombreker uit deur die lekstroom na aarde om die beurt op elke stroombaan aan te lê en teken die resultate aan.

Let op vir watter baan die hoogste uitklinkstroom verkry word. Indien die AL-stroombreker uitklink voordat die aangeslane waarde bereik word, teken aan by watter waarde uitklinking plaasgevind het. Meet die uitklinkstroom vyf maal en gaan na vir voldoening aan die vereistes van 4.12 (d).

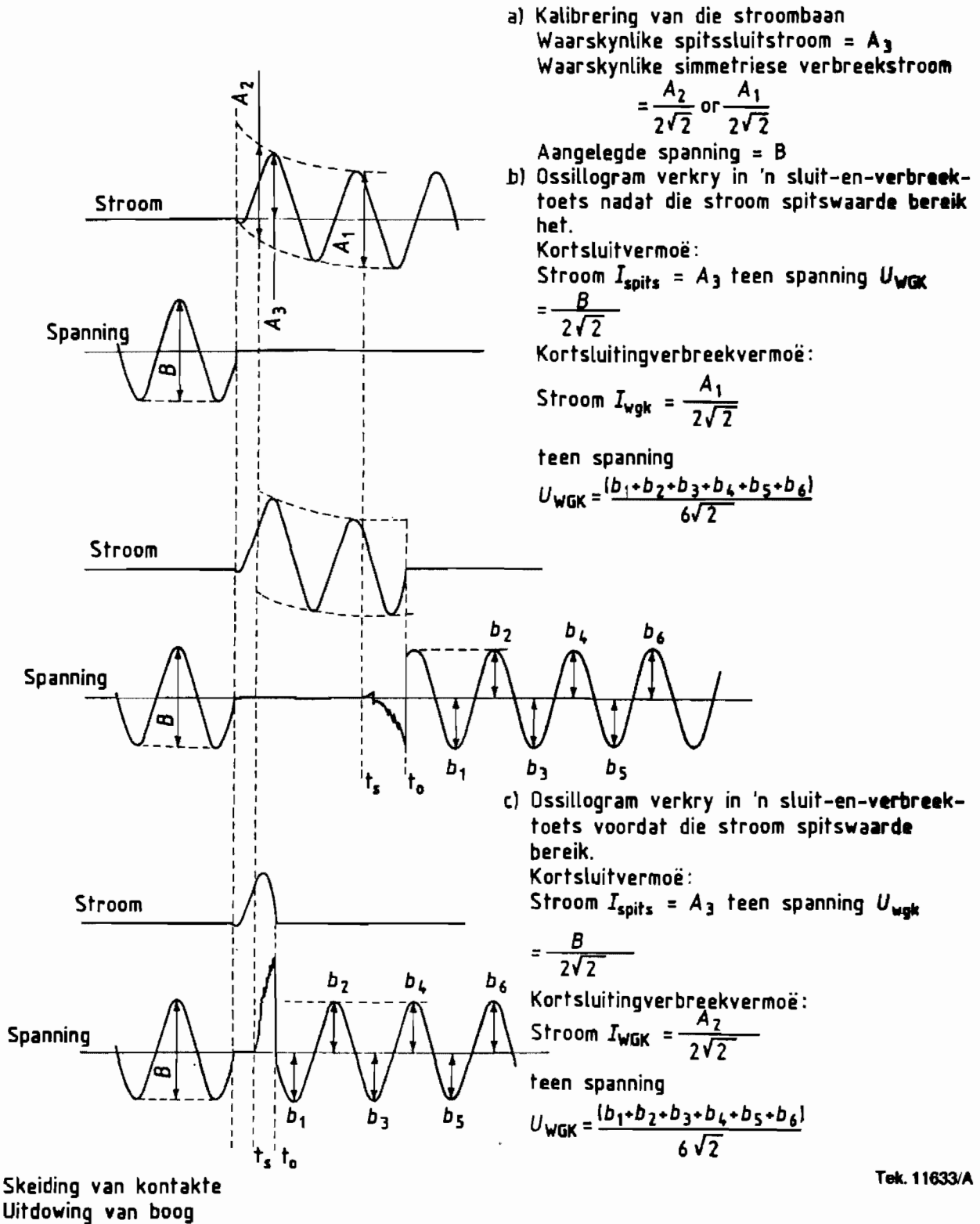

Fig. 2—Verifiëring van Sluit- en Breekvermoë in Kortsluittoestande met WS

- 6.14.4 *Sluiting van AL-stroombreker op aangeslane aardlekuitklinkstroom, $I\Delta_n$* : Met die AL-stroombreker soos in 6.14.2 (a) en (b) bekrag, maar onder nullas, en met die toetskring gekalibreer om die aangeslane aardlekstroom te lewer, sluit die kontakte van die AL-stroombreker. Voer die toets in die geval van 'n driefase-uit deur die lekstroom om die beurt op elke stroombaan aan te lê.

Teken die tydsverloop aan tussen die oomblik waarop die stroom begin vloei en die oomblik waarop die kontakte van die AL-stroombreker begin oopgaan. Meet die werktjye vir vyf werkings en gaan na vir voldoening aan 4.12 (e).

- 6.14.5 *Toetse teen aangeslane lasstroom*: Met die AL-stroombreker net voor en tydens elke toets belas teen die aangeslane stroom soos vir normale diens, herhaal die toetse in 6.14.2, 6.14.3 en 6.14.4 om die beurt en gaan na vir voldoening aan die vereistes van onderskeidelik 4.12 (c), (d) en (e).

Opm.: Die aangeslane stroom kan teen enige toepaslike spanning gesirkuleer word, behalwe waar die toevoer na die aanvoel- en werktjestelle teen aangeslane spanning moet geskied.

- 6.15 **TOETS VIR PRESTASIE VAN 'N AL-STROOMBREKER IN AARDLEKTOESTANDE BY LAE TEMPERATUUR**: Herhaal die toetse in 6.14.2 en 6.14.3, maar kondisioneer die AL-stroombreker in elke geval minstens ses uur lank by 'n omgewingstemperatuur van tussen -4°C en -6°C . Hou hierdie temperatuur gedurende die toets vol.

Moenie die AL-stroombreker gedurende die kondisioneertyd bekrag nie. Voer die toets in die geval van 'n driefase-AL-stroombreker slegs uit op die baan ten opsigte waarvan die hoogste uitklink-stroomwaarde gedurende die toetse by kamertemperatuur aangeteken is.

Opm.: Ten einde ysvorming te voorkom, maak seker dat die doupunt van die lug in die toetskamer hoogstens -6°C is.

- 6.16 **TOETS VIR PRESTASIE VAN 'N AL-STROOMBREKER IN AARDLEKTOESTANDE BY HOË TEMPERATUUR**.

- 6.16.1 Herhaal die toetse in 6.14.2 en 6.14.3, maar kondisioneer die AL-stroombreker in elke geval minstens ses uur lank by 'n omgewingstemperatuur van tussen 38°C en 40°C . Hou hierdie temperatuur gedurende die toets vol.

Moenie die AL-stroombreker gedurende die kondisioneertyd bekrag nie. Voer die toets in die geval van 'n driefase-AL-stroombreker slegs uit op die baan ten opsigte waarvan die hoogste uitklinkstroomwaarde gedurende die toetse by kamertemperatuur aangeteken is.

- 6.16.2 Herhaal die toets in 6.16.1 terwyl die AL-stroombreker die aangeslane stroom dra. Voer die toets slegs uit nadat termies bestendige toestande bereik is.

Opm.: Die aangeslane stroom kan by enige toepaslike spanning gesirkuleer word, behalwe waar die toevoer na die aanvoel- en werktjestelle teen aangeslane spanning moet geskied.

- 6.17 **HOUVERMOËTOETS OP TOETSKNOP**.

- 6.17.1 *Montering en toevoer*: Monteer die AL-stroombreker soos vir normale diens (met alle deksels in posisie) en bekrag dit teen $110 \pm 5\%$ van die aangeslane spanning.

- 6.17.2 *Prosedure*:

Opm.: Moenie die AL-stroombreker gedurende die toets smeer of op ander wyse kondisioneer nie.

Laat die AL-stroombreker vir 1 000 siklusse (wat elk uit een sluit- en een breekwerking bestaan) sonder stroom met gebruik van die toetsknop werk. Gaan na vir voldoening aan 4.13.

- 6.18 **TOETS VIR DESENSITERING**: Verbind 'n weerstand van $1,5\ \Omega$ tussen die nulgeleiertoevoerverbinding en die nulgeleierlasverbinding van die AL-stroombreker (kyk Fig. 3).

Met die AL-stroombreker soos vir normale diens gemonteer en teen die aangeslane spanning bekrag, sluit die AL-stroombrekerkontakte. Begin met 'n stroom van ongeveer $0,2 I\Delta_n$ en lê 'n stroom wat geleidelik verhoog word, tussen enige lynaanluiter aan die laskant en die nulgeleier aan. Teken aan by watter waarde van die stroom die AL-stroombreker uitklink. Herhaal die toets met die AL-stroombreker bekrag teen—

- (a) hoë spanning (110% van die aangeslane spanning of 110% van die hoogste spanning van die aangeslane spanningsbestek, soos toepaslik), en
- (b) lae spanning (70% van die aangeslane spanning of 70% van die laagste spanning van die aangeslane spanningsbestek, soos toepaslik). Gaan na vir voldoening aan 4.14.

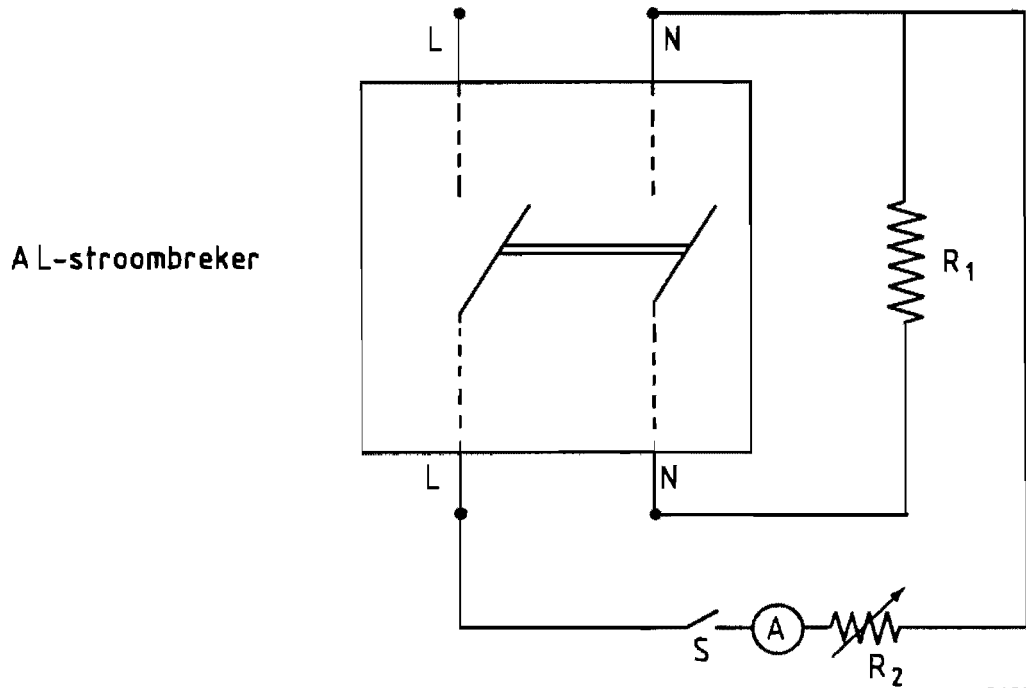

$R_1 = 1,5 \Omega$ weerstand
 $R_2 =$ Reëlbare weerstand
 $A =$ Milliammeter
 $S =$ Skakelaar

Fig. 3—Bedradingsdiagram vir Desensiteringstoets

6.19 TOETS VIR UITWERKING VAN KAPASITIEWE STROOM.

- (a) Verbind, deur middel van 'n afsonderlike elektroniese skakelaar (om kontakwip uit te skakel), 'n kapasitor met die waarde wat in Tabel 8 aangegee word teenoor die aangeslane aardlekuitklinkstroom van die AL-stroombreker wat getoets word, tussen die lasaansluiter en aarde in die geval van 'n eenfase-AL-stroombreker of om die beurt tussen elke stroombaan en aarde in die geval van 'n driefase-AL-stroombreker.
- (b) Met die AL-stroombreker soos vir normale diens gemonteer en teen die aangeslane spanning bekrag, sluit die AL-stroombrekerkontakte.
- (c) Skakel die skakelaar wat die kapasitor verbind, aan.
- (d) Voer die toets 50 maal uit en ontlaai die kapasitor na elke toets.
- (e) Gaan na vir voldoening aan 4.15.

TABEL 8—WAARDES VIR KAPASITORS

1	2
Aangeslane aardlekuitklinkstroom van AL-stroombreker, mA	Waarde van kapasitor, μF
30	0,1
10	0,033
5	0,016

OPM: Die bronimpedansie (Z) moet groter as $0,44 \Omega$ ($R = 0,433 \Omega$; $X_L = 0,0174 \Omega$) wees.

6.20 BRANDBAARHEIDSTOETS.

- 6.20.1 *Toetseksemplare:* Berei minstens drie toetseksemplare met 'n breedte van ongeveer 12 mm, 'n lengte van ongeveer 50 mm en 'n dikte van ongeveer 12 mm voor uit die toepaslike dele van die AL-stroombreker. (Sny die eksemplare tot 'n dikte van 12 mm indien die dikte van die materiaal 12 mm oorskry.)
- 6.20.2 *Kondisionering:* Kondisioneer die eksemplare minstens 18 uur lank in 'n atmosfeer met 'n relatiewe humiditeit van $75 \pm 5\%$ en 'n temperatuur van $20 \pm 2^\circ C$. Toets elke eksemplaar binne drie minute nadat dit uit die beheerde atmosfeer verwyder is.

- 6.20.3 *Apparaat:* 'n Toetsoond met 'n verhittingskamer soos in Fig. 7 aangetoon. Die oppervlakte van die opening bo in die koniese deksel is ongeveer 700 mm^2 en die totale oppervlakte van die lugtoevoeropeninge aan die onderkant van die oond is ongeveer 70 mm^2 . 'n Ligte draadstiebeuel kan gebruik word om die eksemplaar te steun en die steun moet so opgestel word dat die eksemplaar in die middel van die verhittingskamer gehou word, met die langste afmeting vertikaal en die boonste ent ongeveer 70 mm onder die voorbrandvlam. Die apparaat word verhit deur 'n elektriese stroom wat op geskikte wyse gereguleer word, deur 'n verhittingselement rondom die verhittingskamer te stuur.
- 6.20.4 *Temperatuurmeting:* Beskou die temperatuur wat geregistreer word deur 'n termokoppel wat op die hoogte van die middel van die eksemplaar en ewe ver van die binneoppervlak van die kamer en die eksemplaar geplaas is, as die temperatuur van die verhittingskamer.
- 6.20.5 *Prosedure:* Laat die eksemplaar in die verhittingskamer hang, verhoog die temperatuur van die verhittingskamer tot $300 \pm 5 \text{ }^\circ\text{C}$ terwyl die eksemplaar en voorbrandvlam dogehou word en hou hierdie temperatuur vyf minute lank vol. Teken enige eksemplaar wat brand of wat vlambare dampe afgee wat by die voorbrandvlam aan die brand slaan, as defektief aan.
- 6.21 TOETS VIR LEESBAARHEID VAN ETIKETTE EN KLEWING VAN KLEEFETIKETTE.
- 6.21.1 *Voorbereiding van eksemplare:* Kondisioneer drie AL-stroombrekers $168 \pm$ twee uur lank in 'n geventileerde oond by $70 \pm 2 \text{ }^\circ\text{C}$. In die geval van 'n kleefetiket, trek die etiket binne drie minute nadat elke AL-stroombreker uit die oond gehaal is, oor ongeveer 'n kwart van die lengte daarvan af (sonder om die res van die etiket uit die oorspronklike posisie te verwyder). Laat die AL-stroombreker (minstens vier uur lank) tot kamertemperatuur afkoel voordat die toets hieronder beskryf, uitgevoer word.
- 6.21.2 *Prosedure:*
- (a) *Alle etikette:* Week 'n stuk kaasdoek wat voldoen aan die vereistes vir graad 1-kaasdoek van SABS 446 'Verbandgaas (stof en deppers) en kaasdoek' in kraanwater en vryf die kaasdoek altesaam 30 maal in elke rigting (vorentoe en agtertoe) oor die merke op die etiket terwyl 'n druk van $0,05\text{--}0,1 \text{ MPa}$ aangewend word. Herhaal die toets met kaasdoek wat in petroleumeter geweek is en ondersoek dan die merke en gaan na vir voldoening aan 5.3.
- (b) *Kleefetikette:* Gebruik 'n trekskaal en 'n geskikte klamp wat aan die vry ent van die etiket (kyk 6.21.1) bevestig is om die etiket van die AL-stroombreker te probeer verwyder deur 'n trekkrag van $0,15\text{--}0,18 \text{ N/mm}$ van die etiketbreedte vyf sekondes lank in 'n rigting loodreg op die etiketoppervlak aan te wend. Gaan na vir voldoening aan die toepaslike vereiste van 5.3.

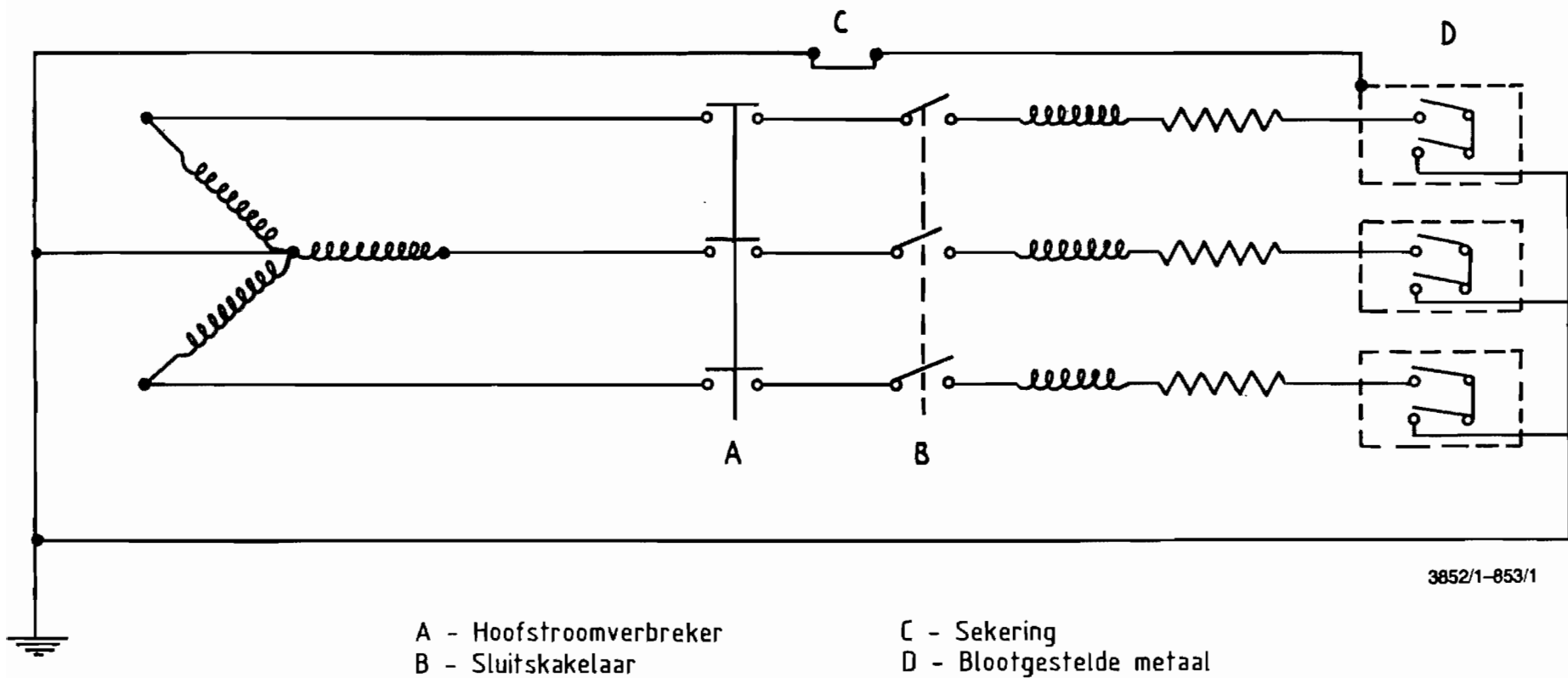
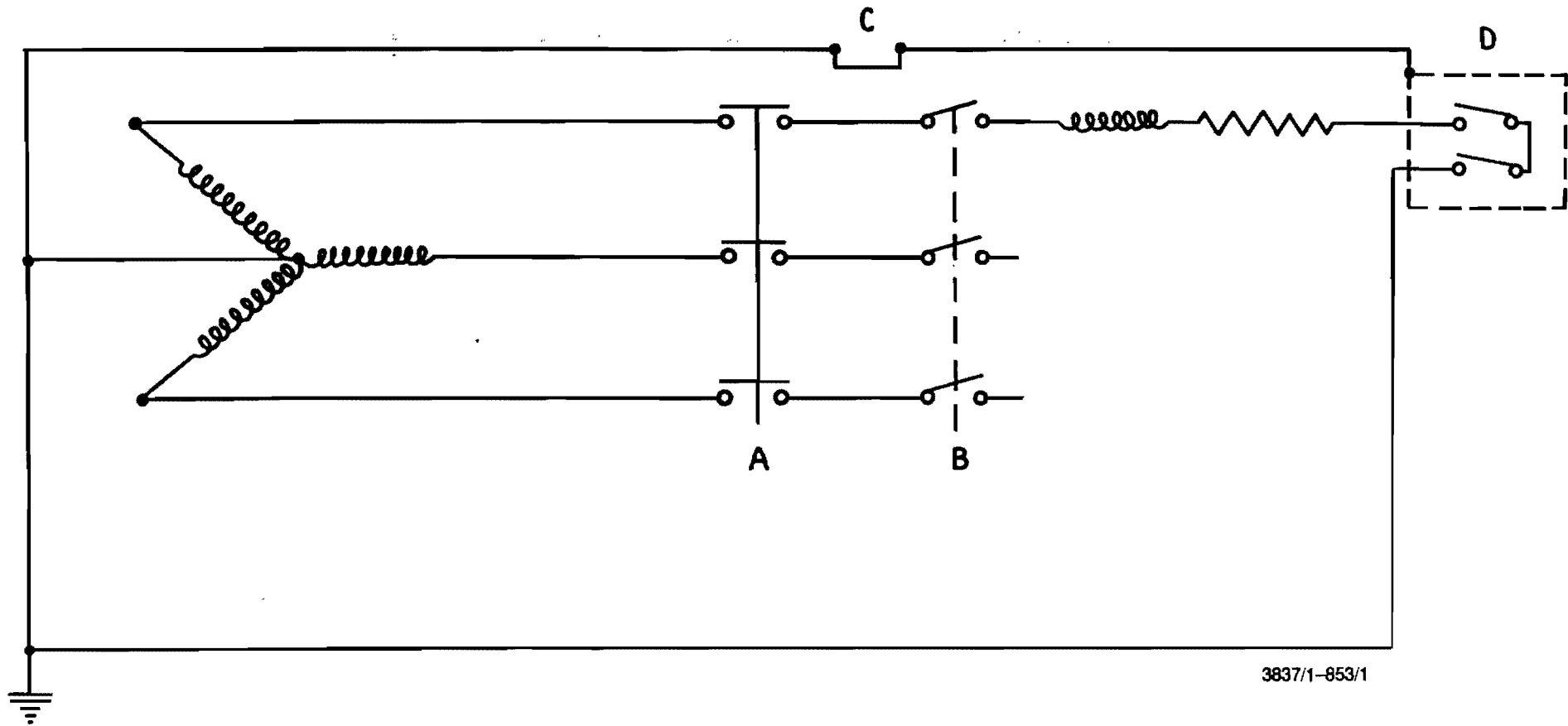

Fig. 4—Stroombaandiagram vir Verbreekvermoëtoets op Tweepoolstroomverbrekers



3837/1-853/1

- | | |
|-------------------------|--------------------------|
| A - Hoofstroomverbreker | C - Sekering |
| B - Sluitskakelaar | D - Blootgestelde metaal |

Fig. 5—Stroombaandiagram vir Alternatiewe Verbreekvermoëtoets op Tweepoolstroomverbrekers

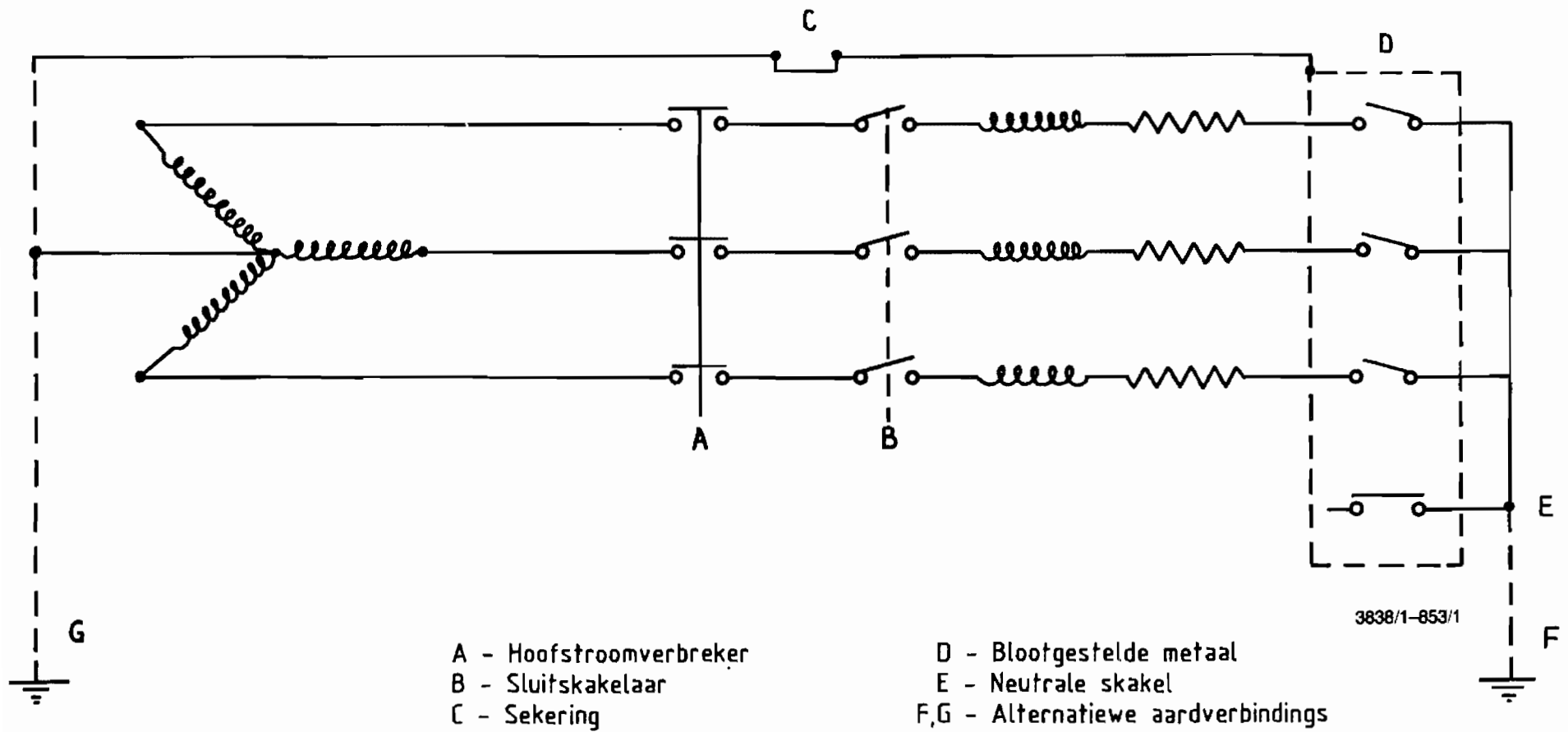
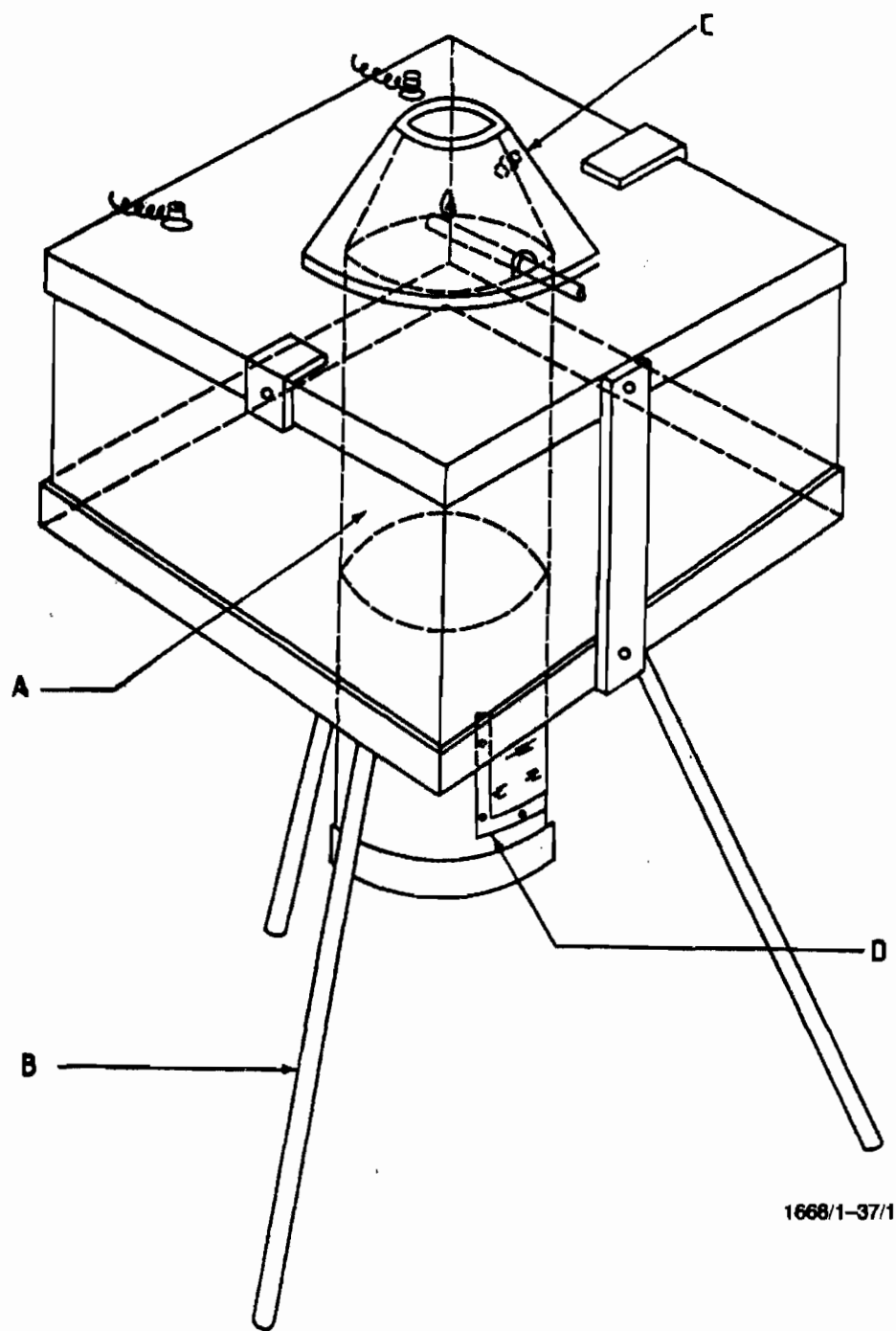

Fig. 6—Stroombaandiagram vir Verbreekvermoëtoets op Driepoolstroomverbrekers



1668/1-37/1

A - Verhittingskamer
B - Driepootsteun

C - Koniese deksel
D - Waarnemingskamer

Fig. 7 (a) — Skets van Opgestelde Apparaat

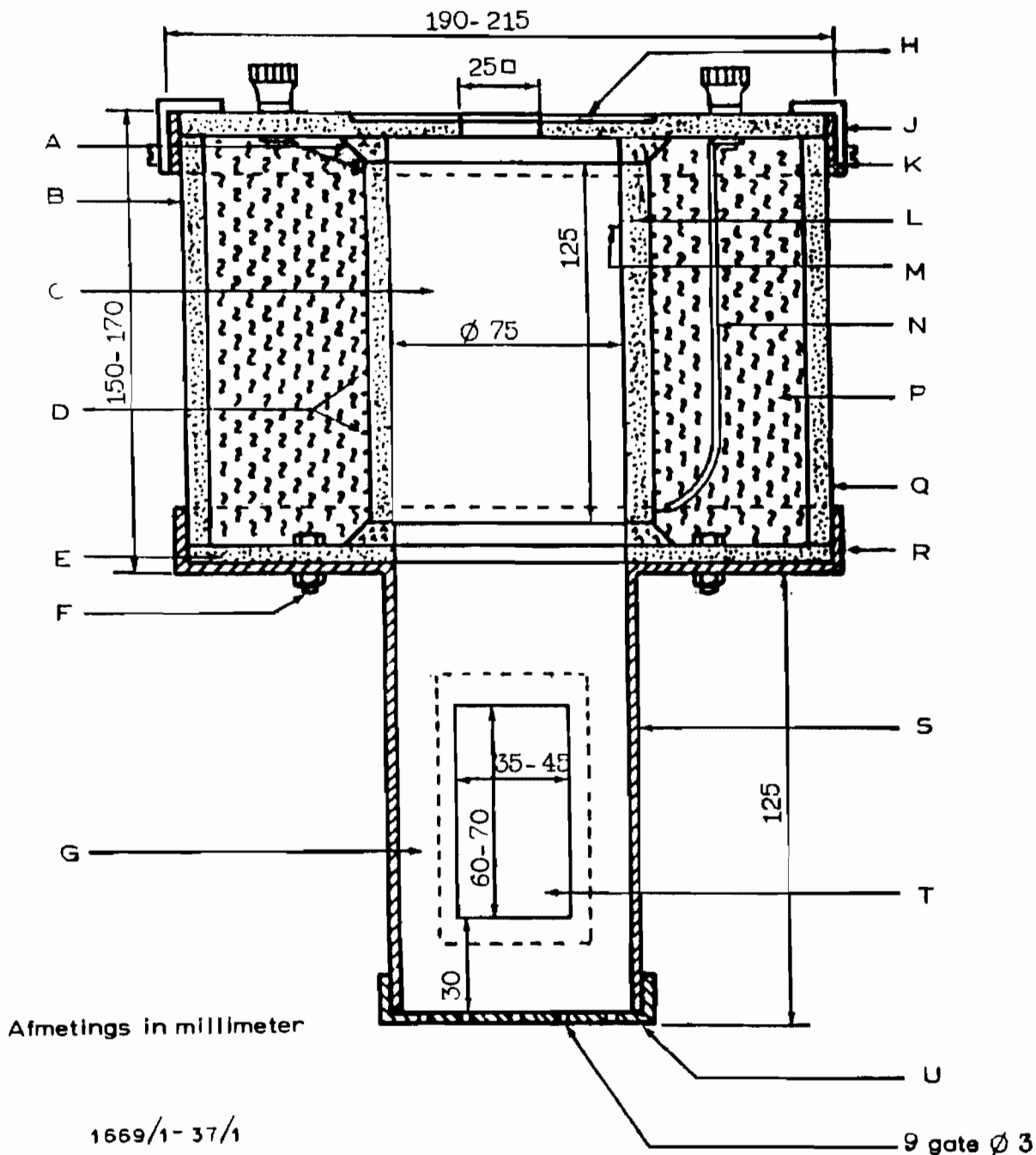

- | | |
|---|--|
| A - Vuurvaste sement | K - Metaalband |
| B - Asbessementplaat | L - Buis van vuurvaste klei of shika |
| C - Verhittingskamer | M - Termokoppel |
| D - Nichroomelement | N - Hittebestande isolasie |
| E - Asbesbord | P - Pakking van asbeswol of magnesia-asbes |
| F - Geelkoperbout | Q - Asbessementplaat |
| G - Waarnemingskamer | R - Hoekyster |
| H - Inlating vir plasing van koniese deksel | S - Metaalsilinder |
| J - Metaalknip | T - Mikavenster |
| | U - Skroef- of glydop |

Fig. 7 (b) - Besonderhede van Oond

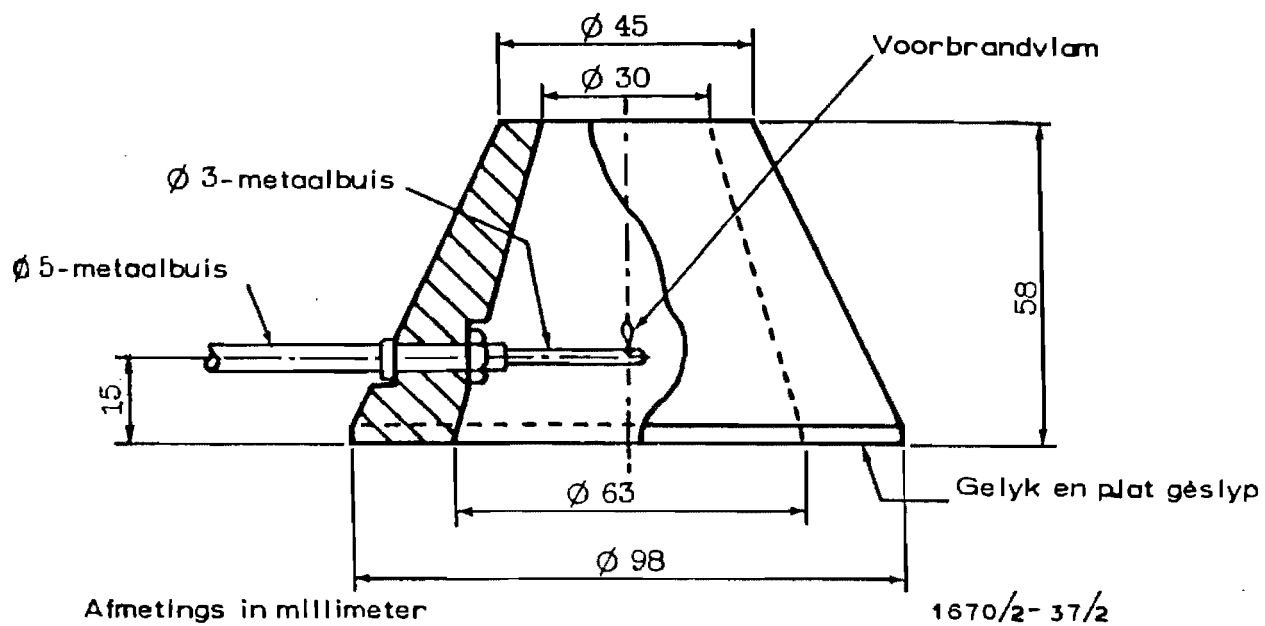
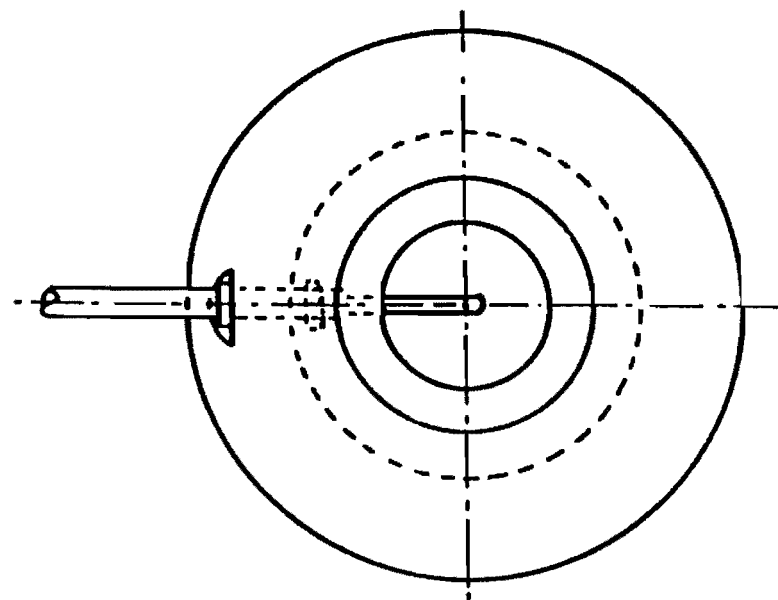

Fig. 7 (c) - Besonderhede van Koniese Deksel

SCHEDULE

COMPULSORY SPECIFICATION FOR EARTH LEAKAGE PROTECTION UNITS

1. SCOPE.
 - 1.1 This specification covers earth leakage protection units (circuit-breakers) for use in domestic and industrial or similar electrical installations and connected to a source of alternating current supply operating at a frequency of 50 Hz, the neutral conductor of which is connected to the general mass of earth on the supply side, and subject to the following limitations:

(a) Maximum rated voltage	500 V.
(b) Maximum rated current	100 A.
(c) Maximum rated earth leakage tripping current.....	30 mA.
(d) Ambient temperature	-5 °C to +40 °C.
 - 1.2 The earth leakage protection units covered by this specification are intended to reduce fire and electrocution hazards caused by current leaking from line and neutral conductors to earth.
 - 1.3 This specification does not cover earth leakage protection units intended for service under extreme operating conditions such as continuous high atmospheric humidity, atmospheric pollution, mechanical vibration, mechanical shock, and excessively high or low temperatures.
2. DEFINITIONS.
 - 2.1 For the purposes of this specification the following definitions shall apply:

Acceptable: Acceptable to the authority administering the specification.

a-contact: A control contact or auxiliary contact that is closed when the main contacts of the mechanical switching device are closed and open when they are open.

b-contact: A control contact or auxiliary contact that is open when the main contacts of the mechanical switching device are closed and closed when they are open.

Breaking capacity: The highest prospective current that, according to the manufacturer, the earth leakage circuit-breaker will break and make-and-break successfully at the rated voltage under prescribed conditions of use and behaviour.

Circuit-breaker (breaker): A mechanical switching device, capable of making, carrying and breaking currents under normal circuit conditions and also making, carrying for a specified time, and breaking currents under specified abnormal circuit conditions such as those of short-circuit or earth fault.

Note: A circuit-breaker is usually intended to operate infrequently although some types are suitable for frequent operation.

Double-pole circuit-breaker: A circuit-breaker having two poles for connection in the two conductors of a supply, each pole being fitted with one or more different releases, the poles being so coupled (mechanically) with each other that they operate together and if a fault on *any one* pole occurs, the supply will be isolated.

Single-pole and neutral circuit-breaker: A circuit-breaker having two poles that are coupled mechanically in such a manner as to operate together, and only one of which is fitted with one or more different releases.

Single-pole and switched-neutral circuit-breaker: A single-pole circuit-breaker fitted with a switched neutral that is arranged to operate with the pole of the circuit-breaker, and to close before and open after the pole contacts, for the purpose of isolating the neutral conductor.

Single-pole circuit-breaker: A circuit-breaker having one pole, the pole being fitted with one or more different releases.

Triple-pole and neutral circuit-breaker: A circuit-breaker having four poles, three of which are fitted with one or more different releases, all the poles being so coupled (mechanically) that they operate together, a fault on one or more phases resulting in isolation of the supply.

Note: The three poles fitted with releases are intended for connection in the phase conductors, and the fourth pole in the neutral conductor, of a three-phase four-wire supply.

Triple-pole and switched-neutral circuit-breaker: A triple-pole circuit-breaker fitted with a switched neutral that is arranged to operate with the main poles of the circuit-breaker, and to close before and open after the pole contacts, for the purpose of isolating the neutral conductor in a three-phase four-wire supply.

Triple-pole circuit-breaker: A circuit-breaker having three poles each being fitted with one or more different releases, and so coupled (mechanically) that they operate together.

Note: This arrangement is intended for use on a three-phase supply where control of the three phases is required to be simultaneous and were a fault on one or more phases will result in isolation of the supply.

Clearance: The shortest distance, measured through air, between two conductive parts.

Creepage distance: The shortest path, measured between two conductive parts along the surface of an insulating material.

Note: A joint between two pieces of insulating material is considered part of the surface.

Current: When applied to an alternating current circuit, the root-mean-square value of the current.

Earth fault current: The current flowing to earth owing to an insulation fault.

Earth leakage current: The current flowing from live parts of the installation to earth in the absence of any insulation fault.

Earth leakage protection circuit-breaker (EL circuit-breaker): An EL circuit-breaker capable of sensing the sum of an earth leakage and earth fault current in a circuit and of interrupting the circuit when this current exceeds a predetermined value.

Earth leakage tripping current: The value of leakage current to earth that will cause an EL circuit-breaker to operate.

Inherent resetting time: The time interval between a breaking operation during specified abnormal conditions and the successful reclosing of the breaker under normal conditions.

Pole: A conducting path in an EL circuit-breaker equipped with a set of contacts for carrying, making and breaking the main current through the EL circuit-breaker.

Power-frequency recovery voltage: The recovery voltage after the transient voltage phenomena have subsided.

Prospective current: The current that would flow on the making of a circuit where the circuit is equipped for the insertion of an EL circuit-breaker when a link of negligible impedance is inserted instead of the EL circuit-breaker. (In some circuits the link may replace the EL circuit-breaker and the connecting leads from the supply.)

Rated load current: The highest load current, assigned by the manufacturer, that an EL circuit-breaker is capable of carrying continuously at the rated voltage under specified conditions, without exceeding the temperature limits specified.

Rated short-time withstand current: The current, assigned by the manufacturer, that an EL circuit-breaker can carry in the closed position during a specified short time under prescribed conditions of use and behaviour.

Rated value: The numerical value of a quantity (such as voltage, current) included in the rating and indicated in the marking.

Rated voltage: The highest voltage, assigned by the manufacturer, at which the EL circuit-breaker may be used.

Recovery voltage: The voltage that appears across the terminals of a pole of an EL circuit-breaker after breaking of the current.

Note: This voltage may be considered in two successive intervals of time, one during which a transient voltage exists, followed by a second one during which power-frequency voltage alone exists.

Release:

Non-time-delay (overcurrent) release: A tripping device without any purposely delayed action.

Overcurrent release: A release that permits a circuit-breaker to open with or without delay when the current in the release exceeds a predetermined value.

Shunt release: A trip coil energized from the main circuit or from a separate auxiliary supply through a relay, a switch or other means.

Time-delay (overcurrent) release: A trip device with a purposely delayed action.

Undervoltage release: A release that permits an EL circuit-breaker to open with or without delay, when the voltage across the terminals of the release falls below a predetermined value and that permits the circuit-breaker to be closed when the voltage across the terminals is above a predetermined value.

Solid neutral: In an EL circuit-breaker, a conducting path which is not equipped with a set of contacts and to which the neutral paths, both incoming and outgoing, are connected one at each end.

Switched neutral: A pair of contacts in a conducting path normally at or about earth potential, capable of carrying the rated current of the EL circuit-breaker, and also capable of carrying, for a specified time, currents under specified abnormal circuit conditions (such as those of short-circuit), but not designed to make or break currents through the circuit.

Transient recovery voltage (TRV): The recovery voltage during the time in which it has a significant transient character.

Note:

(a) The transient recovery voltage may be oscillatory or non-oscillatory or a combination of these, depending on the characteristics of the circuit and the circuit-breaker. It includes the voltage shift of the neutral of a polyphase circuit.

(b) The transient recovery voltage in three-phase circuits is, unless otherwise stated, the voltage across the first pole to clear because this voltage is generally higher than that which appears across each of the other two poles.

Trip-free EL circuit-breaker: An EL circuit-breaker in which the automatic release mechanism will, under fault conditions, open the contacts of the EL circuit-breaker independently of the means used to close the contacts, and will ensure that the contacts are not held closed against a condition where tripping should occur.

Tripping: The opening of an EL circuit-breaker either manually or automatically.

Tripping time: The interval of time between the application of a steady overcurrent or earth leakage current and the interruption of the circuit.

Voltage: When applied to an alternating current circuit, the root-mean-square value of the voltage.

3. DESIGN AND CONSTRUCTION.

3.1 STANDARD OF WORKMANSHIP AND FINISH: All work shall be properly executed and finished and shall be so arranged as not to constitute a hazard.

3.2 MOULDED CASE: The operating mechanism of an EL circuit-breaker shall be contained in a moulded case made of a non-combustible insulating material that will not allow the escape of flame or molten metal through the openings surrounding the operating toggle.

3.3 PROTECTION.

3.3.1 Live parts of an EL circuit-breaker intended for open surface mounting shall be protected against inadvertent contact by means of acceptably strong covers of insulating material.

3.3.2 Live parts on the underside of an EL circuit-breaker designed for mounting on a surface shall—

(a) be covered by a shield or barrier of insulating material; or

(b) be countersunk at least 3 mm below the surface of its base and covered with a waterproof insulating sealing compound that will not flow during any of the tests specified in Section 6; or

(c) have a minimum clearance of 6 mm from the mounting surface and be riveted, upset or otherwise acceptably prevented from loosening.

3.4 CLEARANCES AND CREEPAGE DISTANCES: All clearances and creepage distances shall be as large as is practicable and, in order to break the continuity of conducting deposits that may form, creepages shall, wherever practicable, incorporate ridges.

3.5 MOUNTING: Each EL circuit-breaker shall have at least two holes for mounting purposes or an alternative method of mounting that will ensure acceptable stability.

3.6 MODE OF OPERATION

3.6.1 An EL circuit-breaker shall be arranged for manual closing and opening and for automatic stripping. The mechanism shall be trip-free.

3.6.2 The actuating mechanism shall be such that when an EL circuit-breaker is mounted in the normal manner, the contacts cannot close by themselves as a result of failure of the mechanism.

Note: The mounting of an EL circuit-breaker on a vertical plane with its major axis vertical or horizontal shall be considered as mounted in the normal manner.

3.6.3 The tripping of an EL circuit-breaker under any conditions within its ratings shall not cause the contacts that break the circuit to bounce or show any tendency to reclose.

3.7 ARCH SHIELDS: Means shall be provided to ensure that when a multi pole EL circuit-breaker operates, there is no arcing between the poles.

3.8 TRIP INDICATION: An EL circuit-breaker shall be so designed that when it has been tripped, a clear indication to that effect is visible to the user.

3.9 TERMINALS.

3.9.1 An EL circuit-breaker shall be provided with suitable terminals for the connection of copper conductors of the size given in column 2 of Table 1, appropriate to the current rating of the EL circuit-breaker. The terminals of an EL circuit-breaker with an intermediate rating shall accommodate conductors of the nominal cross-sectional area specified for the next higher current rating.

TABLE 1—WIRING TERMINALS (COPPER CONDUCTORS)

1	2
Rated current of circuit-breaker, A	PVC-covered copper conductor, quantity and nominal cross-sectional area, mm ² , min.
Not exceeding 10	2 × 1,5
16	2 × 4,0
20	2 × 4,0
25	2 × 4,0
32,5	2 × 6,0
40	2 × 10,0
50	16,0
63	25,0
80	35,0
100	50,0

3.9.2 Terminals shall be so designed that they do not allow the conductors to be displaced and are not themselves displaced in a manner detrimental to the operation of the EL circuit-breaker or the effectiveness of the insulation [i.e. the minimum prescribed values for clearances and creepage distances specified in 3.3.2 (b) and (c) shall be maintained under all conditions of normal operation of the EL circuit-breaker].

3.9.3 Each terminal for the connection of an external conductor shall be so arranged that it is readily accessible under the intended conditions of use, and an earth terminal (when provided) shall, in addition, be—

- (a) suitably protected against corrosion,
- (b) permanently and indelibly marked with the symbol , and
- (c) of such a size as to accommodate a conductor that complies with the provisions for earth continuity conductors of SABS 0142 'The wiring of premises'.

3.9.4 A wiring terminal need not be such as to accept a conductor directly, i.e. without some suitable termination being applied to the conductor, but where a terminal is intended to accommodate a stranded conductor, means shall be provided to prevent the conductor wires from spreading.

3.9.5 Each wiring terminal screw shall thread into metal and shall have a smooth clean-cut thread that is free from burrs. The end of the screw shall be so shaped that it will not damage the conductor. Except as allowed below, iron and steel, unless present as a constituent of an alloy that is inherently corrosion resistant, shall not be used for terminals.

3.9.6 Terminals of the type in which the external connecting conductors make direct electrical contact with the pole of an EL circuit-breaker and that are not dependend upon to carry the main current of the EL circuit-breaker, may be of iron or steel that has been plated in an acceptable manner with copper, nickel, cadmium, silver or zinc.

3.10 EARTHING: Provision shall be made for the earthing of any exposed metal parts of an EL circuit-breaker that may become live if the insulation of any part of the EL circuit-breaker becomes defective (see also 3.9.3).

TABLE 2—CONDUCTOR SIZES FOR TEMPERATURE RISE AND OVERCURRENT RELEASE TESTS (COPPER)

1	2
Rated current of circuit-breaker, A	Conductor nominal cross-sectional area, mm ²
Not exceeding 10	1,5
16	2,5
20	2,5
25	4
31,5	6
40	10
50	10
63	16
80	25
100	35

4. ELECTRICAL AND PHYSICAL REQUIREMENTS.

4.1 RATINGS: Each EL circuit-breaker shall be rated in terms of voltage, current, breaking capacity or short-time withstand current, and number of poles.

(a) The rated voltage shall not exceed 500 V and the rated load current shall not exceed 100 A.

(b) The breaking capacity shall be 2,5 kA or 20 times the value of the rated current, whichever is the greater.

(c) The rated earth leakage tripping current of an EL circuit breaker shall, subject to a tolerance of $\pm 0_{-50}$ %, be 5, 10 or 30 mA, as applicable.

Note: The values for the rated earth leakage tripping current are recommended by the International Electrotechnical Commission.

4.2 INSULATION RESISTANCE: When determined in accordance with 6.3, the insulation resistance of an EL circuit-breaker shall be at least 10 MΩ.

4.3 UNDERVOLTAGE RELEASE.

4.3.1 When so required, an EL circuit-breaker shall be provided with an undervoltage release.

4.3.2 An EL circuit-breaker having an undervoltage release shall, when tested in accordance with 6.4, open even on a slowly falling voltage (1 % per second) at a value of between 70 % and 35 % of the rated voltage of the undervoltage release.

The undervoltage release shall prevent closing of the circuit-breaker at a voltage below 35 % and shall not prevent closing at and above 85 % of the rated voltage of the undervoltage release.

4.4 SHUNT RELEASE.

4.4.1 When so required, an EL circuit-breaker shall be provided with a voltage-operated shunt release having a specific voltage rating or range of voltage ratings.

4.4.2 An EL circuit-breaker provided with a voltage-operated shunt release shall, when tested in accordance with 6.5, operate on both 70 % and 120 % of the rated voltage of the shunt release.

4.5 OVERCURRENT RELEASE.

4.5.1 *General:*

4.5.1.1 When so required, an EL circuit-breaker shall be fitted with an overcurrent release.

4.5.1.2 The overcurrent release shall be of an adjustable or non-adjustable time-delay type or a non-time-delay type.

4.5.1.3 The current-time characteristic of an EL circuit-breaker shall be that assigned by the manufacturer and marked on the EL circuit-breaker [see 5.1 (k)].

4.5.2 *Time-delay type:*

4.5.2.1 An EL circuit-breaker having a non-adjustable time-delay release shall carry its rated current continuously without tripping but, when tested in accordance with 6.6, shall release automatically within the periods given in Table 3, appropriate to the rated current of the EL circuit-breaker.

4.5.2.2 An adjustable time-delay release shall be such that, when it is adjusted to its maximum setting, the EL circuit-breaker will comply with the requirements of 4.5.2.1

4.5.3 *Non-time-delay-type.* An EL circuit-breaker having a non-time-delay release shall carry its rated current continuously without tripping and, when 135 % of rated current is applied, shall release instantaneously and the arc shall be extinguished within 0,1 second.

TABLE 3—OPERATION OF OVERCURRENT RELEASE

1	2	3	4	5	6	7
Rated current (I), A	Tripping time, max.					
	Percentage of rated current					
	135	200	400	600	1 000	2 000
$I \leq 40$	50 min	3 min	25 s	10,0 s	3,5 s	1,0 s
$40 < I \leq 80$	100 min	4 min				
$80 < I \leq 100$	100 min	6 min	As stated by the manufacturer.			

4.6 OVERLOAD: When tested in accordance with 6.7 or 6.8, as applicable, an EL circuit-breaker shall show no sign of electrical or mechanical failure and no welding, undue burning, or pitting shall occur at the contacts.

4.7 **TEMPERATURE RISE:** When determined in accordance with 6.9, the temperature rise of the insulating materials and of each of the parts of an EL circuit-breaker shall not exceed the relevant value given in Table 4.

TABLE 4—TEMPERATURE RISE

1	2
Parts and types of material*	Temperature rise, °C, max.
(a) Wiring terminals	70
(b) Contacts:	
copper or copper alloys.....	45
silver.....	†
silver-tungsten and other sintered metals	‡
(c) Cotton, silk, paper and similar materials, non-impregnated	65
(d) Cotton, silk, paper and similar materials impregnated with a resin, and enamel when it is used with such materials.....	80
(e) Wire covered with formaldehyde-, polyvinyl-, or epoxy resin or polyurethane, when these are not used with fibrous materials	95
(f) Phenolic composition employed as electrical insulation.....	§80
(g) Mica, glass fibre or asbestos, with binder and impregnation.....	105
(h) Bare coils.....	90
(i) Operating toggles (hand-operated)	25

* Other materials not included in this table shall be deemed acceptable if it has been proved that such materials can operate, without adverse effects, at the temperatures attained in service.

† Limited solely by the necessity of not causing any damage to adjacent parts.

‡ To be specified according to the properties of the metals used and limited by the necessity of not causing any damage to adjacent parts.

§ Unless it has been established that the material is acceptable for use at higher temperatures.

4.8 **MECHANICAL STRENGTH:** When tested in accordance with 6.10, an EL circuit-breaker shall show no sign of cracks or permanent deformation.

4.9 **PERFORMANCE OF AN EL CIRCUIT-BREAKER UNDER EARTH FAULT CONDITIONS:** When an EL circuit-breaker is tested in accordance with 6.11, the unit shall trip, the butter muslin shall not be ignited, and the fuse shall not rupture.

The EL circuit-breaker shall, within 24 hours after the test, be capable of operating successfully at the rated earth leakage tripping current.

4.10 **BREAKING CAPACITY (FOR AN EL CIRCUIT-BREAKER FITTED WITH AN OVERCURRENT RELEASE).**

4.10.1 (a) An EL circuit-breaker shall be capable of once breaking and once making-and-breaking a circuit adjusted for the prospective current with the relevant power factor given in Table 7, appropriate to the breaking capacity of the EL circuit-breaker.

(b) The inherent resetting time of an EL circuit-breaker shall not exceed 15 minutes.

4.10.2 **When an EL circuit-breaker is tested in accordance with 6.12—**

(a) it shall show no sign of electrical or mechanical failure;

(b) the butter muslin placed over the operating toggles shall not be ignited;

(c) the average value of the power-frequency recovery voltage shall be equal to a value corresponding to 110 % of the rated operational voltage [see 6.12.1 (b)] occurring across the terminals of a pole of the EL circuit-breaker immediately before the flow of the test current, and this voltage shall be maintained for a period of at least 0,1 second after extinction of the arc;

Note: This may require that the applied voltage be increased but the tolerance on the prospective peak-making current shall not be exceeded without the consent of the manufacturer.

(d) there shall be no damage to insulation of conductors used to connect the EL circuit-breaker in the circuit;

(e) the fuse connecting metal parts to the neutral of the a.c. power supply shall not rupture;

(f) The EL circuit-breaker shall still comply with the requirements of 4.5.2 for 200 % of the rated current, or 4.5.3, as applicable; and

(g) the EL circuit-breaker shall still be capable of withstanding, for one minute without breakdown, a test voltage of magnitude as given in Table 7, appropriate to the rated voltage of the EL circuit-breaker.

4.11 **SHORT-TIME WITHSTAND CURRENT (FOR AN EL CIRCUIT-BREAKER NOT FITTED WITH AN OVERCURRENT RELEASE):** When tested in accordance with 6.13, an EL circuit-breaker that is not fitted with an overcurrent release shall be capable of once making and carrying for a period not exceeding 40 ms the prospective current appropriate to the specified rated short-time withstand current (not less than 2,5 kA) [see 5.1 (j)], the power factor being that applicable for the breaking capacity class of the same prospective current (see Table 6).

Note: The test shall be conducted with a preceding circuit-breaker or fuse in the circuit, when so requested. Such protection shall be supplied.

4.12 **PERFORMANCE OF AN EL CIRCUIT-BREAKER UNDER EARTH LEAKAGE CONDITIONS.** When an EL circuit-breaker is tested in accordance with 6.14, 6.15 and 6.16—

- (a) the EL circuit-breaker shall on each occasion trip positively;
- (b) under no conditions shall the EL circuit-breaker trip when the value of earth leakage current is less than 50 % of the rated value;
- (c) no value of the operating time for a suddenly applied earth leakage current shall exceed the applicable value given in Table 5;
- (d) all five values of earth leakage current in each test for a gradually applied earth leakage current shall be between $0,5 I_{\Delta_n}$ and I_{Δ_n} , when I_{Δ_n} is the rated earth leakage tripping current; and
- (e) no value of the operating time recorded while the EL circuit-breaker is closed on the rated earth leakage current shall exceed the applicable value given in column 2 of Table 5.

TABLE 5—MAXIMUM OPERATING TIMES FOR VALUES OF EARTH LEAKAGE CURRENT

1 Rated earth leakage tripping current (I_{Δ_n}), A	2, 3, 4 Operating time, s, max.		
	I_{Δ_n}	$2I_{\Delta_n}$	0,25 A
	$I_{\Delta_n} = 0,005$	5	1
$I_{\Delta_n} = 0,01$	5	0,5	0,04
$I_{\Delta_n} = 0,03$	0,5	0,2	0,04

4.13 **TEST AND RESET BUTTONS:** Every EL circuit-breaker shall have a test button that is easily accessible when the EL circuit-breaker is mounted in its normal position, and by means of which the correct functioning of the EL circuit-breaker may be tested. The test button shall preferably be of a light colour (red or green shall not be used). The test facility shall be so connected in the circuit as to ensure that the sensing device, the amplifier, and the circuit-breaker mechanism are all tested for failure or deterioration. The test facility shall be so designed that a current equivalent to 125–175 % of the rated earth leakage tripping current flows through the sensing device when the test button is operated with the EL circuit-breaker energized at its rated voltage. Where necessary, a reset button shall be provided but this shall not inhibit the functioning of the EL circuit-breaker. The test and the reset buttons shall be identified in accordance with 5.1 (d).

When tested in accordance with 6.17, the test button shall show no signs of mechanical failure and the EL circuit-breaker shall still trip when the test button is operated.

4.14 **DESENSITIZATION CAUSED BY LOOP RESISTANCE OF A NEUTRAL TO EARTH FAULT:** When tested in accordance with 6.18, an EL circuit-breaker shall trip before the earth leakage exceeds twice the rated value.

4.15 **TRIPPING CAUSED BY CAPACITIVE CURRENTS:** When tested in accordance with 6.19, an EL circuit-breaker shall not trip more than five times.

4.16 **NON-COMBUSTIBILITY:** When tested in accordance with 6.20, materials that are required to be non-combustible shall be incapable of giving off flammable vapours.

5. **MARKING.**

5.1 **EL CIRCUIT-BREAKERS:** The following information shall appear in legible and indelible markings in (unless otherwise required) either or both of the official languages of the Republic of South Africa, either on the body of the EL circuit-breaker or on a label (see 5.3) securely attached to it, as appropriate:

- (a) The rated load current (I_n);
- (b) the rated earth leakage tripping current (I_{Δ_n});

- (c) the "ON" and "OFF" positions of the EL circuit-breaker either on the operating toggle or on the case, in one of the following ways:
 - (1) the symbols | and O for the "ON" and "OFF" positions respectively; or
 - (2) in both official languages, the words "ON" and "OFF" ("AAN" and "AF");

Note:

- (i) The "ON" or | marking shall denote that the switch is in the up position.
- (ii) The symbol | used for the "ON" position shall be an upright straight line, not 1 or I.
- (d) the words "Test" and "Toets" or the letter T on, or adjacent to, the test button and "Reset" and "Herstel" adjacent to the reset button (if fitted);
- (e) EL circuit-breakers not fitted with an overcurrent release shall be clearly marked: NO OVERLOAD PROTECTION;

Note: The above markings [(a)–(e)] shall be clearly visible to the operator when the EL circuit-breaker is mounted as for normal service. If the markings are on the case or on the cover of the EL circuit-breaker, they shall be adjacent to the operating toggle and visible when the toggle is in the relevant position. Where covers are used for marking, they shall be nonreversible.

- (f) the rated voltage;
- (g) the name, trade name or registered trade mark of the manufacturer or the supplier;
- (h) a catalogue number or type number or other identification marking that will distinguish the EL circuit-breaker from any other type marketed by the manufacturer;
- (i) in the case of an EL circuit-breaker equipped with a neutral terminal, the letters L and N to identify the respective terminals;
- (j) the rated short-time (40 ms) withstand current or breaking capacity class, in kiloamperes;
- (k) the current-time characteristic (this marking may be in code and shall apply only to an EL circuit-breaker fitted with an overcurrent release);
- (l) an acceptable identification mark for the line and load terminals, or alternatively, direction arrows indicating the entry and exit directions of the supply leads;
- (m) in the case of an EL circuit-breaker not fitted with an overcurrent release and not marked with a rated short-time withstand current value, marking stating that an alternative method of overload protection shall precede the EL circuit-breaker in the circuit.

5.2 The appropriate of the following symbols may also appear in legible and indelible marking on the body of a circuit-breaker:

I_n = rated current

U_n = rated voltage

I_{cn} = rated breaking capacity class, e.g. " $I_{cn} 2,5 \text{ kA}$ "

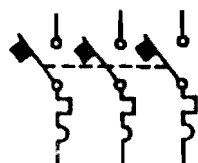

triple-pole thermal magnetic EL circuit-breaker

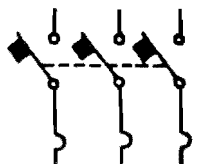

triple-pole magnetic EL circuit-breaker



single-pole and neutral EL circuit-breaker



single-pole and switched-neutral EL circuit-breaker

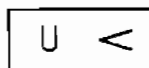

undervoltage relay

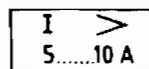

overcurrent relay with a setting range from 5 A to 10 A

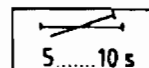

time-lag adjustable from 5 s to 10 s



shunt trip

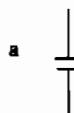

auxillary a-contact

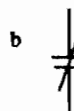

auxillary b-contact

- 5.3 LABELS: Labels (when used) shall be of acceptable material and when they are tested in accordance with 6.21, the marking shall still be legible and, in the case of a stick-on label, it shall not be possible to remove the label in one piece.
- 5.4 EARTH TERMINALS. Any earth terminal shall be permanently and indelibly marked with the symbol \oplus .
- 6. INSPECTION AND METHODS OF TEST.
- 6.1 INSPECTION: Visually examine and, when relevant, measure each EL circuit-breaker for compliance with the relevant requirements of the specification for which tests to assess compliance are not given in 6.3–6.21 (inclusive) (as given in Section 3, 4 and 5).
- 6.2.1 Unless otherwise required, carry out the tests on each EL circuit-breaker as a whole and with the ambient temperature maintained at 15–25 °C.

- 6.2.2 Test each single-pole and switched-neutral EL circuit-breaker, and each single-pole and neutral EL circuit-breaker, as a double-pole EL circuit-breaker.
- 6.2.3 With the exception of the air-core reactor in any phase (which shall be shunted by a resistance of a value such that the current through the resistor is 0,6–0,7 % of the current through the air-core reactor), do not connect in parallel the reactance or resistance components of a test circuit load impedance.
- 6.2.4 Except where otherwise specified, use for the test an alternating current supply of practically sinusoidal waveform and that has a frequency of 50 ± 2 Hz. For any test where no tolerances are stated, the following general tolerances shall apply:
Voltage ± 5 %; Current ± 5 %; Frequency ± 2 Hz; Time ± 5 %.
- 6.3 INSULATION RESISTANCE TEST: Measure at a d.c. voltage of 500 V the insulation resistance in the following positions:
- Between live terminals and any metal parts that would be exposed when the EL circuit-breaker is mounted in its normal position. Do this test (with all exposed metal parts electrically connected together and with all live terminals electrically connected together) with the EL circuit-breaker first in the "ON" position and then in the "OFF" position.
 - Between each incoming and each outgoing terminal, with the EL circuit-breaker in the "OFF" position and, in the case of multipole circuit-breakers, with electrical interconnection between—
 - all incoming terminals, and
 - all outgoing terminals.
 Check for compliance with 4.2.
- 6.4 UNDERVOLTAGE RELEASE TEST: Connect the undervoltage release to a power supply operating at its rated voltage. Reduce the voltage at a rate of 1 % per second until the EL circuit-breaker trips, and record the voltage at this point. Adjust the voltage to 34 % of the rated voltage and try to close the EL circuit-breaker. Adjust the voltage to 85 % of the rated voltage, close the EL circuit-breaker and determine whether or not it remains closed at this voltage. Check for compliance with 4.3.2.
- 6.5 SHUNT RELEASE TEST: Connect the EL circuit-breaker to the power supply and determine whether the EL circuit-breaker trips when the shunt release is energized at a supply voltage of
- 70 %, and
 - 120 %
- of the rated voltage. Check for compliance with 4.4.2.
- 6.6 OVERCURRENT RELEASE TEST.
- 6.6.1 *Mounting and connections:* Mount the EL circuit-breaker as for normal service (with all covers in position) and, using conductors of length at least 1 m and of the size given in Table 2, appropriate to the current rating of EL circuit-breaker, connect it to the power supply.
- 6.6.2 *Procedure:*
- Using any convenient voltage, determine the current-time characteristic of the EL circuit-breaker by operating it at an ambient temperature of 25 ± 5 °C at all the following percentages of rated current:

135	1 000
200	2 000
400	

Test each pole fitted with an overcurrent release separately except that for calibration at 135 % of the rated current, all poles shall be tested simultaneously and shall be equally loaded. Test two poles, or one pole and the neutral, to ensure that the currents through the sensing device are balanced. Check for compliance with 4.5.1.3.

Note: Where the characteristics of an EL circuit-breaker are such that the above points do not produce a smooth curve, additional intermediate points may be taken as required.
 - Finally, verify the current rating by operating the EL circuit-breaker at its rated through all poles simultaneously for at least two hours.
- 6.7 OVERLOAD TEST FOR AN EL CIRCUIT-BREAKERS FITTED WITH AN OVERCURRENT RELEASE.
- 6.7.1 *Test circuit:* With the EL circuit-breaker mounted as for normal service, connect it into a circuit in which the current has been adjusted to 600 ± 5 % of the relevant rated value and the applied voltage to 100 ± 5 % of the rated voltage of the EL circuit-breaker. Use an a.c. circuit having a lagging power factor of 0,45–0,5.
- 6.7.2 *Procedure:* Unless otherwise required, close and open the EL circuit-breaker 50 times consecutively at the rate of six operation cycles per minute and ensure that the contacts do not remain closed for more than two seconds in each cycle. In the case of multi-pole EL circuit-breakers, test simultaneously all poles.

- intended to interrupt current, each pole carrying the current specified above. In the case of an EL circuit-breaker with no overcurrent release but fitted with a shunt release, carry out the test as described above but so energize the release (by applying a voltage equal to the rated voltage of the release) that the circuit-breaker opens 20–40 ms after closing. Check for compliance with 4.6.
- 6.8 OVERLOAD TEST FOR AN EL CIRCUIT-BREAKER NOT FITTED WITH AN OVERCURRENT RELEASE.
- 6.8.1 *Test circuit:* With the EL circuit-breaker mounted as for normal service, connect it into a circuit in which the current has been adjusted to 150 % of the relevant rated value with a power factor of 0,95 and the applied voltage has been adjusted to 110 ± 5 % of the rated voltage of the EL circuit-breaker.
- 6.8.2 *Procedure:* Close and open the EL circuit-breaker five times consecutively and ensure that the contacts do not remain closed for more than two seconds in each cycle. In the case of multipole EL circuit-breakers, test simultaneously all poles intended to interrupt current, each pole carrying the current specified above. Check for compliance with 4.6.
- 6.9 TEMPERATURE RISE TEST: Mount the EL circuit-breaker as for normal service (with all covers in position) in a place where there are no draughts and where the ambient air temperature is 25 ± 5 °C.
- Using conductors each of length at least 1 m and of the size given in Table 2, appropriate to the current rating of the EL circuit-breaker, connect the EL circuit-breaker to the power supply and pass the rated current through the EL circuit-breaker for a period of two hours or until thermal equilibrium is attained. Then measure the relevant temperatures (see Table 4) by means of thermocouples or any other acceptable method, at the points where the temperatures are judged to be highest. Check for compliance with 4.7.
- 6.10 MECHANICAL STRENGTH TEST.
- 6.10.1 *Apparatus:*
- (a) A *mechanical strength test apparatus* as shown in Fig. 1. The metal cylinder A of mass 250 g and of external diameter 25 mm fits loosely over the guide rod B. The guide rod is not rigidly fixed to the frame of the test apparatus and can be easily slid up and down. A hard fibre washer C of diameter 25 mm and of thickness 12,5 mm is fixed to the bottom of the guide rod.
- (b) A *rectangular hardwood block D* that fits on the base of the test apparatus.
- 6.10.2 *Specimen:* Use one EL circuit-breaker from the sample.
- 6.10.3 *Procedure:*
- (a) Place the hardwood block on the base of the test apparatus and firmly hold or otherwise mount the specimen on the block with its mounting surface down (i.e. toggle uppermost).
- (b) Raise the guide rod and so move the block that, when the guide rod is lowered, the fibre washer rests on the surface of the specimen. Lower the guide rod, raise the metal cylinder to a height of 250 mm above the fibre washer, and allow the cylinder to drop onto the fibre washer.
- (c) Repeat the drop twice, ensuring that the toggle is subjected to one drop when it is in the OFF position.
- (d) So turn the specimen that it lies on its side on the block and proceed as described in (b) above, subjecting the specimen to three drops, two at random (but not on an edge of the specimen) and one approximately in the middle of the terminal guard.
- (e) Turn the specimen onto the other side and repeat the procedure given in (d) above.
- (f) After the specimen has been subjected to nine drops, examine it for compliance with 4.8.
- 6.11 TEST FOR PERFORMANCE OF AN EL CIRCUIT-BREAKER UNDER EARTH FAULT CONDITIONS: Connect a 1 A fuse between the earthed conductor of the supply circuit and any metal parts that will be exposed when the EL circuit-breaker is mounted in its normal position. Connect all exposed metal parts together electrically. Connect the EL circuit-breaker to a power supply having an open circuit voltage of 100 ± 5 % of the rated voltage.
- Adjust the impedance of the load to provide a prospective earth fault current of 500 A with a power factor of 0,45–0,50. Cover that part of the surface of the EL circuit-breaker in which the toggle is situated with clean dry butter muslin that complies with requirement for Grade 1 butter muslin of SABS 446 'Absorbent gauze (fabric and swabs) and butter muslin'. Ensure that any cut or torn edges of the muslin are not exposed directly to the arc openings where flame may be emitted. Apply the earth fault current once by means of a separate switch in the supply circuit and once by means of the EL circuit-breaker switch, with the separate switch closed (i.e. close the EL circuit-breaker switch onto the fault.) In the case of a three-phase EL circuit-breaker test only one pole. Check for compliance with 4.9.
- Immediately after the test, check the EL circuit-breaker for performance under earth leakage conditions at room temperature, the earth leakage current being applied gradually (see 6.14.3). Should the unit fail to comply with the requirement given in 4.12 (d), repeat the earth leakage test (as in 6.14.3) after 24 hours.

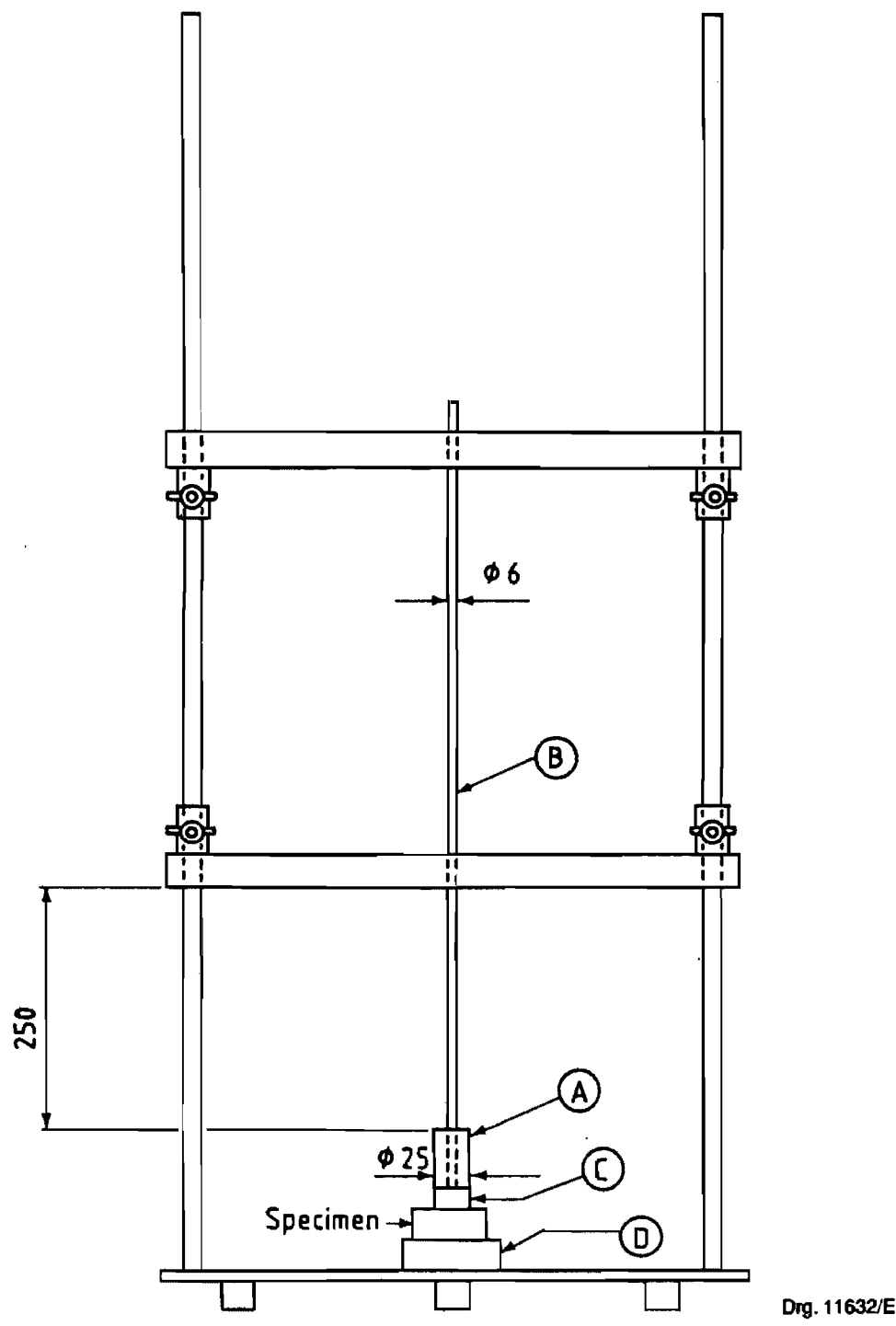

Dimensions in millimetres

Fig. 1—Apparatus for Mechanical Strength Test

6.12 **BREAKING CAPACITY TEST (FOR AN EL CIRCUIT-BREAKER FITTED WITH AN OVERCURRENT RELEASE)**

6.12.1 *Power supply:*

(a) *Alternating current:* A source capable of giving $100 \pm 5\%$ of the relevant prospective current with the corresponding lagging power factor given, any current-limiting impedances used being placed between the circuit-breaker and the power supply.

(b) *Voltage:* The voltage of the test circuit immediately before the flow of the test current shall be not less than 105% and not more than 115% of the rated voltage of the circuit-breaker.

6.12.2 *Mounting:* Mount the EL circuit-breaker as for normal service and connect it into the test circuit with conductors each of length (on both the load and the line sides) 0,5–0,75 m and of the size given in Table 2, appropriate to the current rating of the EL circuit-breaker.

6.12.3 *Earthing of metal parts:* If the EL circuit-breaker contains any exposed metal parts or is intended for mounting on a metal plate or support, connect all such metal parts (through a tinned-copper wire fuse of nominal diameter 0,125 mm and of length 75–100 mm) to the neutral wire.

6.12.4 *Butter muslin:* Cover that part of the surface of the EL circuit-breaker in which the operating toggle is situated with clean dry butter muslin that complies with the requirements for Grade 1 butter muslin of SABS 446 'Absorbent gauze (fabric and swabs) and butter muslin'. Ensure that any cut or torn edges of the muslin are not exposed directly to the arc openings where flame may be emitted.

6.12.5 *Test circuit:*

(a) *Double-pole, single-pole and neutral, and single-pole and switched-neutral circuit-breakers:* Use a circuit as specified in Fig. 4 or Fig. 5.

(b) *Triple-pole or triple-pole and neutral circuit-breakers:* Use a circuit as specified in Fig. 6.

(c) *Resistance of voltage measuring circuit:* The value of the resistance of the voltage measuring circuit connected across the terminals of a pole of an EL circuit-breaker shall be at least 100 Ω per volt of the power-frequency recovery voltage.

6.12.6 *Procedure:*

(a) With the test circuit adjusted to the appropriate value of voltage, prospective current and power factor as given in Table 6, subject the EL circuit-breaker to a break test, using point-on-wave switching to obtain the greatest practicable transient current. Maintain the recovery voltage for at least 0,1 second after extinction of the arc. After an interval of not less than two minutes and not more than 15 minutes (the inherent resetting time), subject the EL circuit-breaker to a make-and-break test, maintaining the recovery voltage for at least 0,1 second after extinction of the arc. During both the tests, record by means of an oscillograph or by other acceptable means, the amplitudes and duration of voltage and current.

TABLE 6—VALUES OF PROSPECTIVE CURRENT AND POWER FACTORS FOR BREAKING CAPACITY TEST

1	2	3
Breaking capacity class	Prospective current, symmetrical r.m.s., A	Power factor, lagging
SABS 2,5 kA.....	2 500 AC	0,45–0,5
SABS 5 kA.....	5 000 AC	0,45–0,5
SABS 7,5 kA.....	7 500 AC	0,45–0,5
SABS 10 kA.....	10 000 AC	0,45–0,5
SABS 12,5 kA.....	12 500 AC	0,25–0,3
SABS 15 kA.....	15 000 AC	0,25–0,3
SABS 20 kA.....	20 000 AC	0,25–0,3
SABS 25 kA.....	25 000 AC	0,15–0,2

(b) After the break and make-and-break tests, check the EL circuit-breaker for compliance with 4.10.2 (a), (b), (d) and (e).

(c) Determine from the oscillograms the power-frequency recovery voltage in accordance with 6.12.7 below, and check for compliance with 4.10.2 (c).

(d) Test, in accordance with 6.6.2, the overcurrent release (if fitted) of the EL circuit-breaker at 135 % or 200 % of the rated current, as applicable, and check for compliance with 4.10.2 (f).

(e) Finally, apply between the parts listed in 6.3 'Insulation resistance test', an alternating voltage of approximately sinusoidal waveform and of the relevant value given in Table 7.

Start the test at a voltage not exceeding one-third of the appropriate test voltage and increase it to its full value as rapidly as is consistent with the true value being indicated by the measuring instrument. Maintain the full test voltage for one minute and then decrease it rapidly to not more than one third of this value before switching off. Check for compliance with 4.10.2 (g).

TABLE 7—TEST VOLTAGE

1	2
Rated voltage, V of EL circuit-breaker	Test voltage, V (r.m.s.)
Not exceeding 250	1 500
Exceeding 250 but not exceeding 500	2 000

6.12.7 Interpretation of oscillograms:

(a) *Determination of applied voltage and power-frequency voltage:* From the oscillograms recorded during the calibration of the circuit the break test and the make-and-break test, determine the applied voltage and the power-frequency recovery voltage by estimating these voltages using the examples as shown in Fig. 2. (Fig. 2 applies to the make-and-break test.)

Measure the power-frequency voltage during the first half-cycle (without transients) after extinction of the arc, and during the next five successive peaks. Take the sum of these six peaks divided by $6\sqrt{2}$ as the r.m.s. power-frequency recovery voltage for each phase as shown in Fig. 2 (b) and (c), and check for compliance with 4.10.2 (c).

Note: Attention is drawn to the fact that because of the influence of—

- (1) short time variations in the insulation resistance of a circuit-breaker,
- (2) short time variations in the insulation resistance of arc gaps, or
- (3) the resistance in recovery voltage measuring circuits, or any combination of these, certain types of triple-pole circuit-breaker exhibit a tendency for the power-frequency recovery voltage across each pole of the circuit-breaker to undergo short time variations in amplitude that fall below 105 % and rise above 115 % of the rated voltage of the circuit-breaker. Other types of triple-pole circuit-breaker have been observed to exhibit erratic short time variations in the power-frequency recovery voltage during which the amplitude varies from approximately zero value to full recovery voltage across one pole, while the recovery voltage across the other two poles shows short time variations in amplitude from above to below the specified limits. Where doubt exists regarding compliance of the circuit-breaker with the requirements for power-frequency recovery voltage, take three additional circuit-breakers and subject them to the break and make-and-break tests in accordance with the procedure given in 6.12.6 above, but with the neutral of the source of supply being connected to the common earth connection (Point F in Fig. 6).

(b) *Determination of the prospective breaking current:* Determine the value of the prospective breaking current by comparing the current trace obtained in the calibration of the circuit [see Fig. 2 (a)] with that obtained during the break test the oscillogram of which is not shown in Fig. 2, or that obtained in the make-and-break test [see Fig. 2 (b)]. Take the prospective breaking current in each phase to be the value of the r.m.s. power-frequency component of the calibration current that corresponds to the instant of separation of the arcing contacts [values corresponding to A_1 or A_2 of Fig. 2 (a)]. Ensure that the prospective current in any one phase does not differ from the average value by more than 10 %.

(c) *Determination of the prospective peak-making current:* Determine the peak-making current from the calibration oscillogram and take its value as being equal to A_3 [see Fig. 2 (a)]. In the case of a three-phase test, take the highest of the A_3 values obtained from the oscillogram.

Note: For tests on single-pole circuit-breakers, attention is drawn to the fact that the prospective peak-making current determined from the calibration oscillogram may differ from the value of the prospective peak-making current corresponding to the test, depending on the instant of making.

6.13 SHORT-TIME WITHSTAND CURRENT TEST (FOR EL AN CIRCUIT-BREAKER NOT FITTED WITH AN OVERCURRENT RELEASE): Use the breaking capacity test circuit given in 6.12.

6.14 TEST FOR PERFORMANCE OF AN EL CIRCUIT-BREAKER UNDER EARTH LEAKAGE CONDITIONS AT ROOM TEMPERATURE (15–25 °C).

6.14.1 *Conditioning:* Condition the EL circuit-breaker under test for at least 6 hours at the specified ambient temperature (see 6.2.1) and maintain this ambient temperature during the test. Do not energize the EL circuit-breaker during the conditioning.

6.14.2 *Suddenly applied earth leakage current:* With the EL circuit-breaker energized at—

- (a) low voltage (70 % of the rated voltage or 70 % of the lowest voltage of the voltage range, as applicable), and
- (b) high voltage (110 % of the rated voltage or 110 % of the highest voltage of the voltage range, as applicable),

and without passing a load current through the EL circuit-breaker (except that, in order to facilitate the test procedure, the contacts of the EL circuit-breaker may be connected to a circuit incorporating a measuring device such as a cathode ray oscillograph, an electromagnetic oscillograph, a digital counter or a recording millivoltmeter, and if such a procedure is adopted, a current not exceeding 50 % of the rated load current of the EL circuit-breaker may be passed through the EL circuit-breaker), suddenly apply, in turn, at each of the energizing voltages, the applicable leakage currents specified in Table 5 and record the time interval between the instant the current starts to flow and the instant at which the contacts of the EL circuit-breaker start to open.

In the case of a three-phase EL circuit-breaker, conduct the test with the leakage current to earth applied to each current path in turn and record the results. Note on which path the highest tripping current is obtained.

Make five measurements of the operating time for each value of the earth leakage current and check for compliance with 4.12 (c).

6.14.3 *Gradually applied earth leakage current:* With the EL circuit-breaker energized as in 6.14.2 (a) and (b), pass a leakage current to earth through the EL circuit-breaker, starting with a current not greater than $0,2 I_{\Delta n}$. Increase the current steadily and try to attain within 30 seconds an earth leakage current equal to $I_{\Delta n}$.

Maintain the current at this value for a period longer than the time specified in column 2 of Table 5, appropriate to the rated earth leakage tripping current. In the case of a three-phase EL circuit-breaker, conduct the test with the leakage current to earth applied to each current path in turn and record the results. Note on which path the highest tripping current is obtained.

Should the EL circuit-breaker trip before the rated value is reached, record the value at which tripping occurs. Make five measurements of the tripping current and check for compliance with 4.12 (d).

6.14.4 *Closing of EL circuit-breaker on rated earth leakage tripping current, $I_{\Delta n}$:* With the EL circuit-breaker energized as in 6.14.2 (a) and (b) but on no-load and with the test circuit calibrated to give rated earth leakage current, close the contacts of the EL circuit-breaker. In the case of a three-phase EL circuit-breaker, conduct the test with the leakage current applied to each current path in turn.

Record the time interval between the instant the current starts to flow and the instant the contacts of the EL circuit-breaker start to open. Measure the operating times for five operations and check for compliance with 4.12 (e).

6.14.5 *Tests at rated load current:* With the EL circuit-breaker carrying rated current as for normal service shortly before and during each test, repeat, in turn, the tests given in 6.14.2, 6.14.3 and 6.14.4 and check for compliance with 4.12 (c), (d) and (e), respectively.

Note: Rated current may be circulated at any appropriate voltage except where the sensing and operating devices must be supplied at rated voltage.

6.15 TEST FOR PERFORMANCE OF AN EL CIRCUIT-BREAKER UNDER EARTH LEAKAGE CONDITIONS AT LOW TEMPERATURE: Repeat the tests given in 6.14.2 and 6.14.3 but in each case condition the EL circuit-breaker for at least six hours at an ambient temperature of between -4 °C and -6 °C . Maintain this temperature during the test.

Do not energize the EL circuit-breaker during the conditioning period. In the case of a three-phase EL circuit-breaker, conduct the test only on the path for which was recorded the highest value of tripping current during the tests at room temperature.

Note: To prevent icing, ensure that the dew point of the air inside the test chamber is not higher than -6 °C .

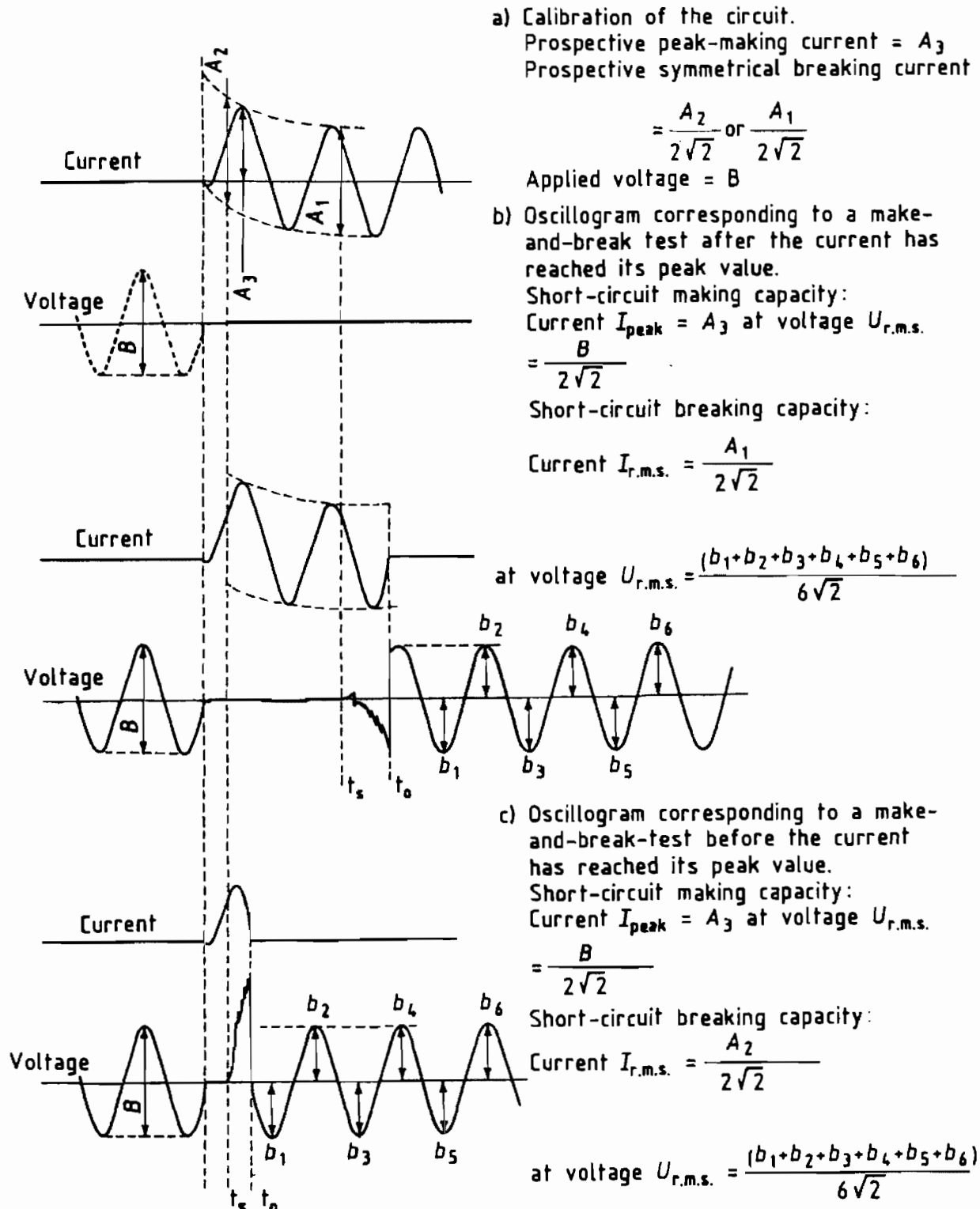

t_s = Separation of contacts
 t_o = Arc extinction

Drg. 11633/E

Fig. 2—Verification of Short-circuit Making and Breaking Capacities on AC

6.16 TEST FOR PERFORMANCE OF AN EL CIRCUIT-BREAKER UNDER EARTH LEAKAGE CONDITIONS AT HIGH TEMPERATURE.

6.16.1 Repeat the test given in 6.14.2 and 6.14.3 but in each case condition the EL circuit-breaker for at least six hours at an ambient temperature of between 38 °C and 40 °C. Maintain this temperature during the test. Do not energize the EL circuit-breaker during the conditioning period. In the case of a three phase EL circuit-breaker, conduct the test only on the path for which was recorded the highest value of tripping current during the tests at room temperature.

6.16.2 Repeat the test given in 6.16.1 but with the EL circuit-breaker carrying rated current. Conduct the test only after thermal steady state conditions have been attained.

Note: Rated current may be circulated at any appropriate voltage except where the sensing and operating devices must be supplied at rated voltage.

6.17 TEST FOR ENDURANCE OF TEST BUTTON.

6.17.1 *Mounting and supply:* Mount the EL circuit-breaker as for normal service (with all covers in position) and energize it at $110 \pm 5\%$ of the rated voltage.

6.17.2 *Procedure:*

Note: Do not lubricate or otherwise condition the EL circuit-breaker during the test.

Operate the EL circuit-breaker carrying no current for 1 000 cycles (each consisting of one make and one break operation), using the test button. Check for compliance with 4.13.

6.18 TEST FOR DESENSITIZATION: Connect a resistance of $1,5 \Omega$ between the supply neutral connection and the load neutral connection of the EL circuit-breaker (see Fig. 3).

With the EL circuit-breaker mounted as for normal service and energized at rated voltage, close the EL circuit-breaker contacts. Starting with a current of approximately $0,2 I_{\Delta n}$, apply a gradually increasing current between any line terminal on the load side and neutral. Record the value of the current at which the EL circuit-breaker trips. Repeat the test with the EL circuit-breaker energized at—

- (a) high voltage (110 % of the rated voltage or 110 % of the highest voltage of the rated voltage range, as relevant), and
- (b) low voltage (70 % of the rated voltage or 70 % of the lowest voltage of the rated voltage range, as relevant). Check for compliance with 4.14.

6.19 TEST FOR EFFECTS OF CAPACITIVE CURRENT.

(a) Connect via a separate electronic switch (to eliminate contact bounce) a capacitor of the value given in Table 9, appropriate to the rated earth leakage tripping current of the EL circuit-breaker under test, between the load terminal and earth in the case of a single-phase EL circuit-breaker, or between each current path and earth, in turn, in the case of a three-phase EL circuit-breaker.

(b) With the EL circuit-breaker mounted as for normal service and energized at rated voltage, close the EL circuit-breaker contacts.

(c) Operate the switch connecting the capacitor.

(d) Perform the test 50 times and discharge the capacitor after each test.

(e) Check for compliance with 4.15.

TABLE 8—VALUES OF CAPACITORS

1	2
Rated earth leakage tripping current of EL circuit-breaker, mA	Value of capacitor, μF
30	0,1
10	0,033
5	0,016

NOTE: The source impedance Z shall be greater than $0,44 \Omega$ ($R = 0,433 \Omega$; $X_L = 0,077 4 \Omega$).

6.20 COMBUSTION TEST.

6.20.1 *Test specimens:* From the appropriate parts of the circuit-breaker, prepare at least three test specimens of width approximately 12 mm, of length approximately 50 mm and of thickness approximately 12 mm. (If the thickness of the material is greater than 12 mm, cut the specimens to a thickness of 12 mm.)

6.20.2 *Conditioning:* Condition the specimens for a period of at least 18 hours in an atmosphere having a relative humidity of $75 \pm 5\%$ and a temperature of $20 \pm 2 \text{ }^\circ\text{C}$. Test every specimen within three minutes after removing it from the controlled atmosphere.

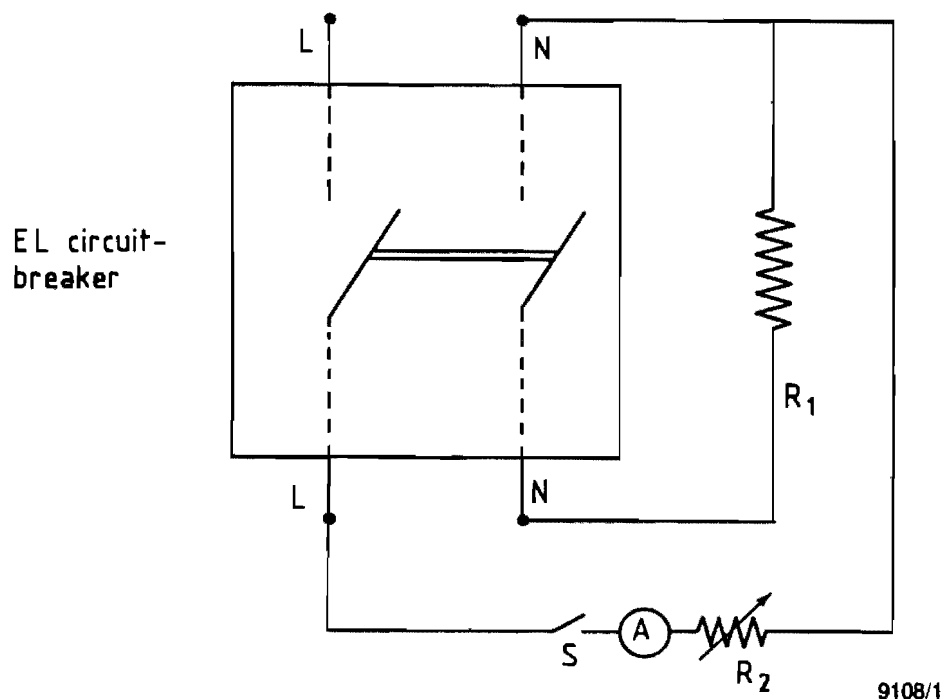

$R_1 = 1,5 \Omega$ resistor
 $R_2 =$ Variable resistor
 $A =$ Milliammeter
 $S =$ Switch

Fig. 3—Wiring Diagram for the Desensitization Test

- 6.20.3 *Apparatus:* A test oven having a heating chamber as shown in Fig. 7. The area of the opening at the top of the conical cover is approximately 700 mm^2 and the total area of the air intake holes at the bottom of the oven is approximately 70 mm^2 . A light stirrup of wire may be used to support the specimen, the support being so arranged that the specimen is held centrally in the heating chamber, with its longest dimension vertical, and its upper end approximately 70 mm below the pilot flame. The apparatus is heating by passing a suitably regulated electric current through a heating element surrounding the heating chamber.
- 6.20.4 *Temperature measurement:* Take as the temperature of the heating chamber that shown by a thermocouple situated at the level of the middle of the specimen and equidistant from the inner surface of the chamber and the specimen.
- 6.20.5 *Procedure:* Suspend the specimen in the heating chamber and, keeping the specimen and pilot flame under observation, raise the temperature of the heating chamber to $300 \pm 5 \text{ }^\circ\text{C}$ and maintain this temperature for a period of five minutes. Report as defective any specimen that burns or gives off flammable vapours that ignite at the pilot flame.

6.21 TEST FOR LEGIBILITY OF LABELS AND ADHERENCE OF STICK-ON LABELS.

6.21.1 *Preparation of specimens:* Condition three EL circuit-breakers in a ventilated oven at 70 ± 2 °C for a period of 168 ± 2 hours. In the case of a stick-on label, within three minutes after removing each EL circuit-breaker from the oven, peel back the label for approximately a quarter of its length (without removing the remainder of the label from its original position). Allow the EL circuit-breaker to cool (for at least four hours) to room temperature before carrying out the test described below.

6.21.2 *Procedure:*

(a) *All labels:* Soak in tap water a piece of butter muslin that complies with the requirements for Grade 1 butter muslin of SABS 446 'Absorbent gauze (fabric and swabs) and butter muslin' and, applying a pressure of 0,05–0,1 MPa, rub the muslin a total of 30 times in each direction (forward and reverse) over the markings on the label. Repeat the test with butter muslin soaked in petroleum spirit and then examine the markings and check for compliance with 5.3.

(b) *Stick-on labels:* Using a spring balance and a suitable clamp attached to the free end of the label (see 6.21.1), try to remove the label from the EL circuit-breaker by pulling the free end with a force of 0,15–0,18 N/mm width of the label for a period of five seconds in a direction at right angles to the surface of the label. Check for compliance with the relevant requirement of 5.3.

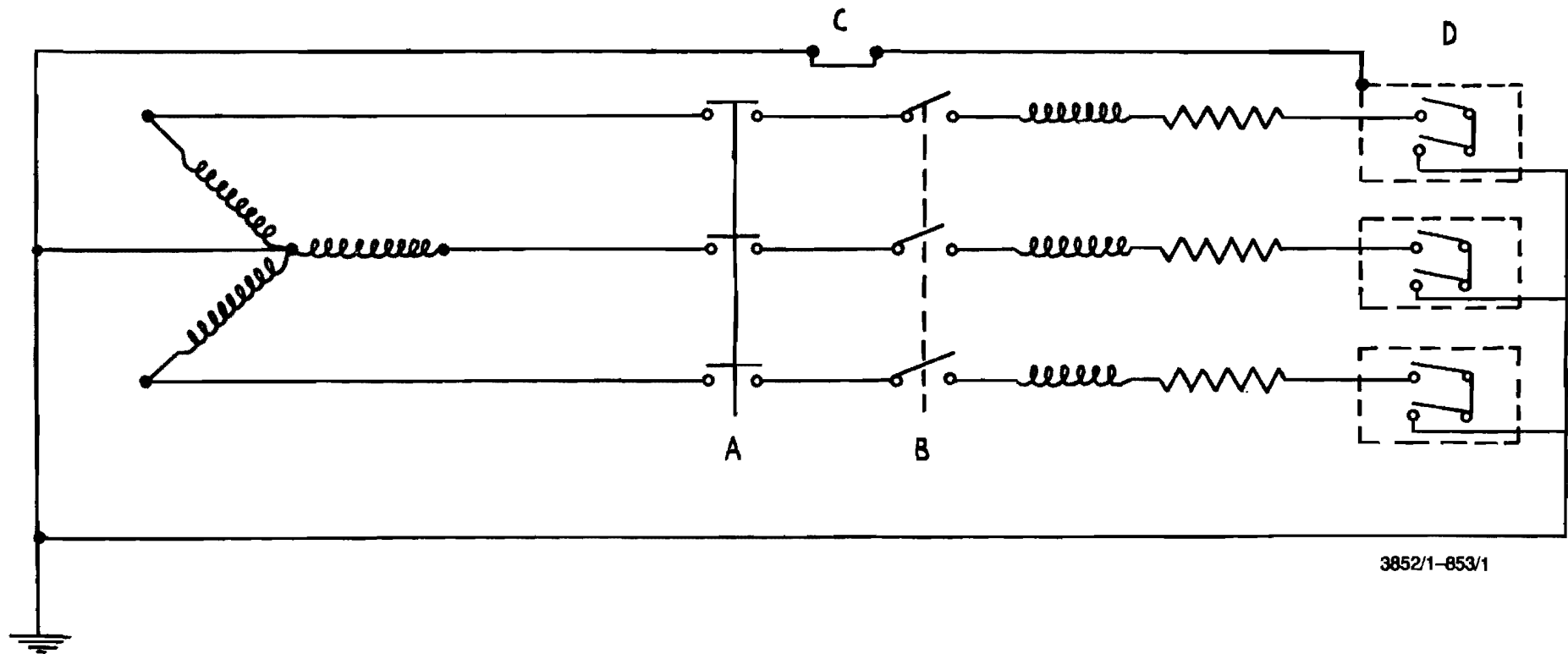

3852/1-853/1

A - Master circuit-breaker
B - Making switch

C - Fuse
D - Exposed metal

Fig. 4—Circuit Diagram for Breaking Capacity Test on Double-pole Circuit-breakers

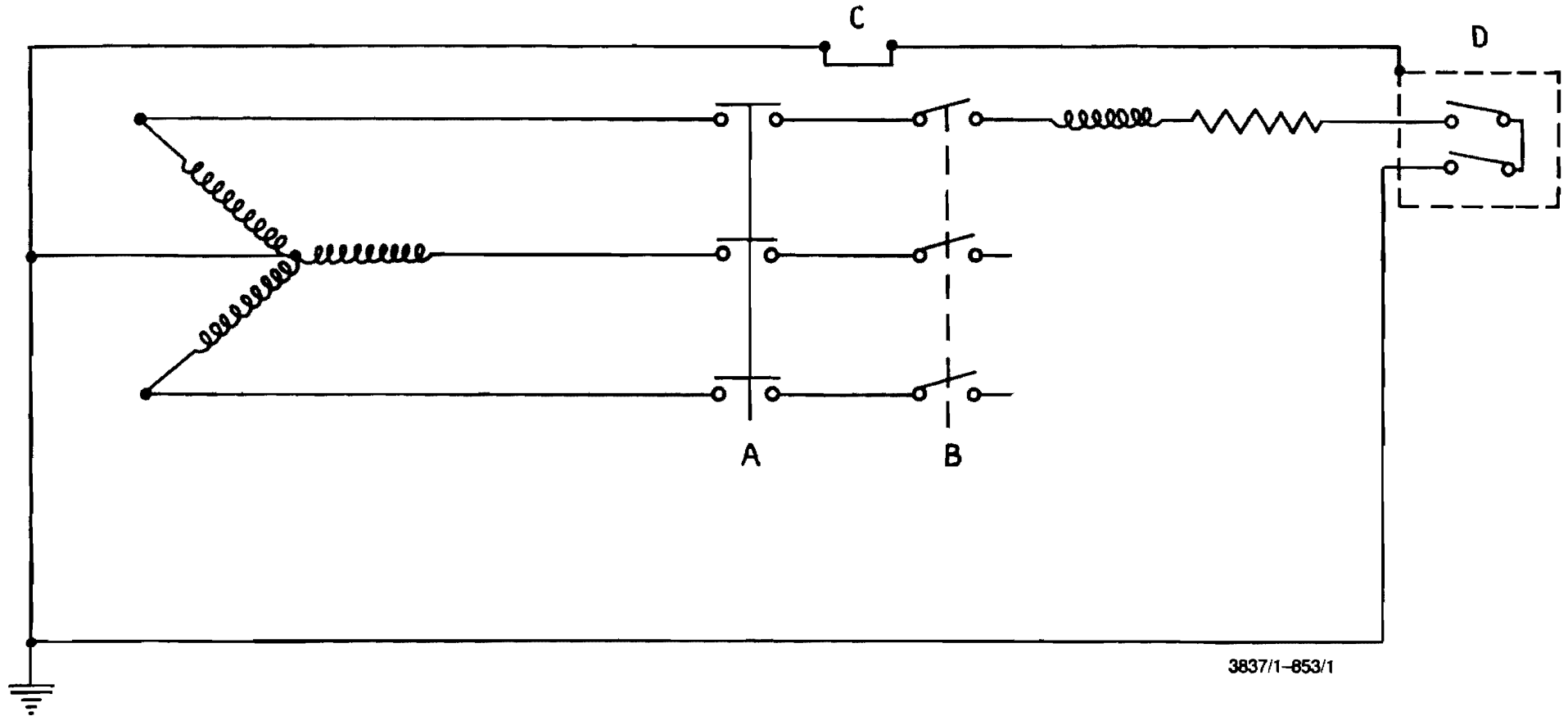

3837/1-853/1

- A - Master circuit-breaker
- B - Making switch
- C - Fuse
- D - Exposed metal

Fig. 5—Alternative Circuit Diagram for Breaking Capacity Test on Double-pole Circuit-breakers

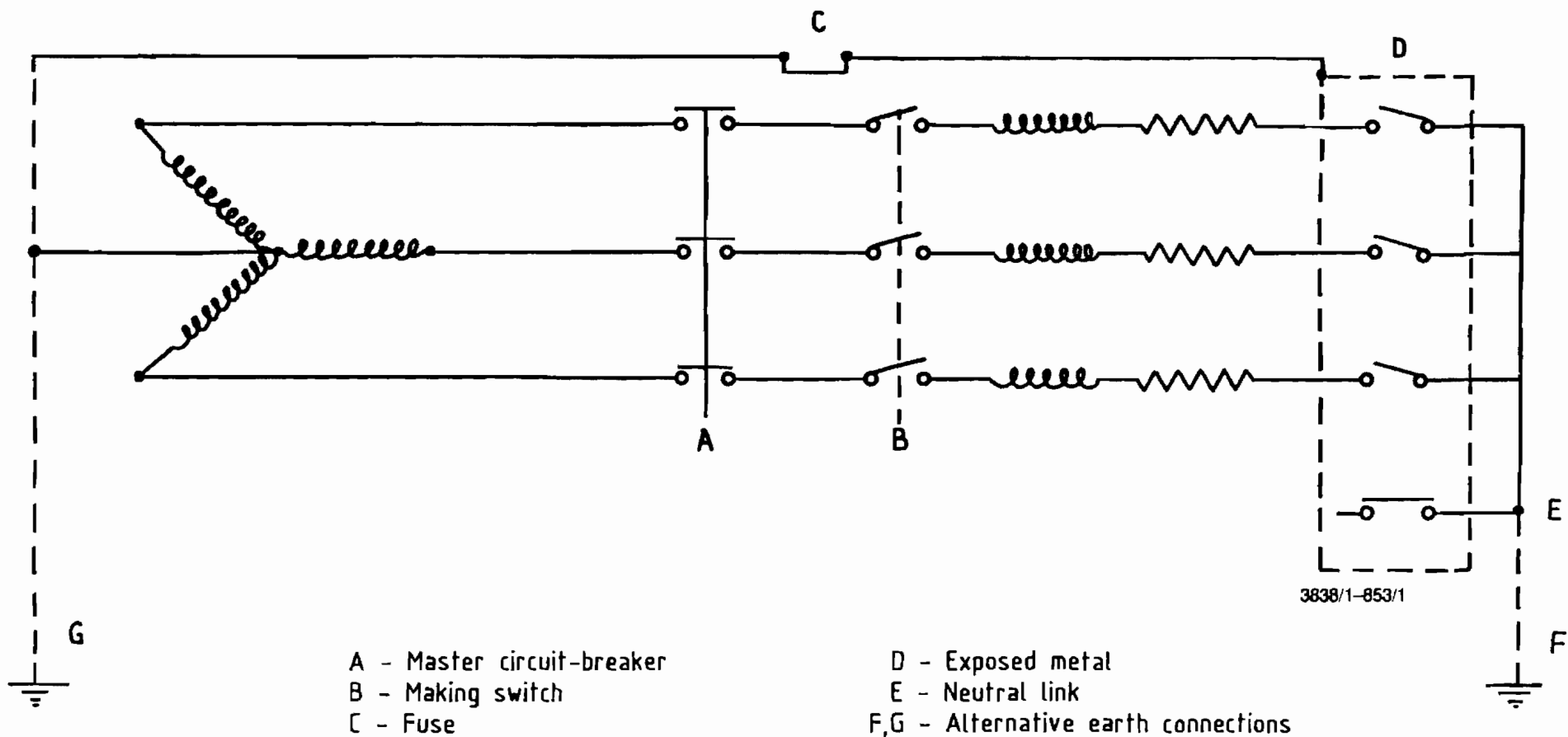
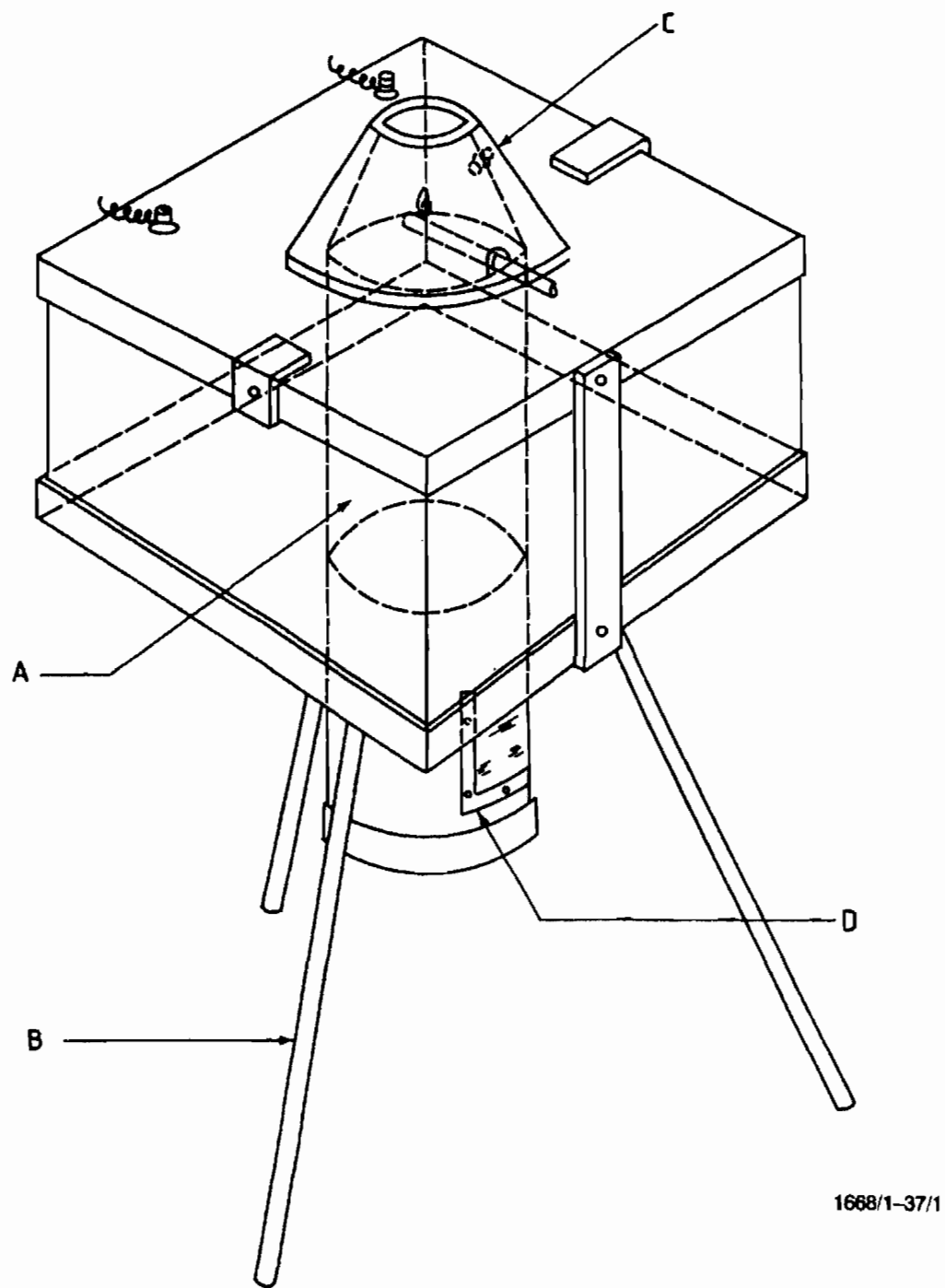

Fig. 6—Circuit Diagram for Breaking Capacity Test on Triple-pole Circuit-breakers



1668/1-37/1

- A - Heating chamber
- B - Tripod support
- C - Conical cover
- D - Observation chamber

Fig. 7 (a)—Sketch of Assembled Apparatus

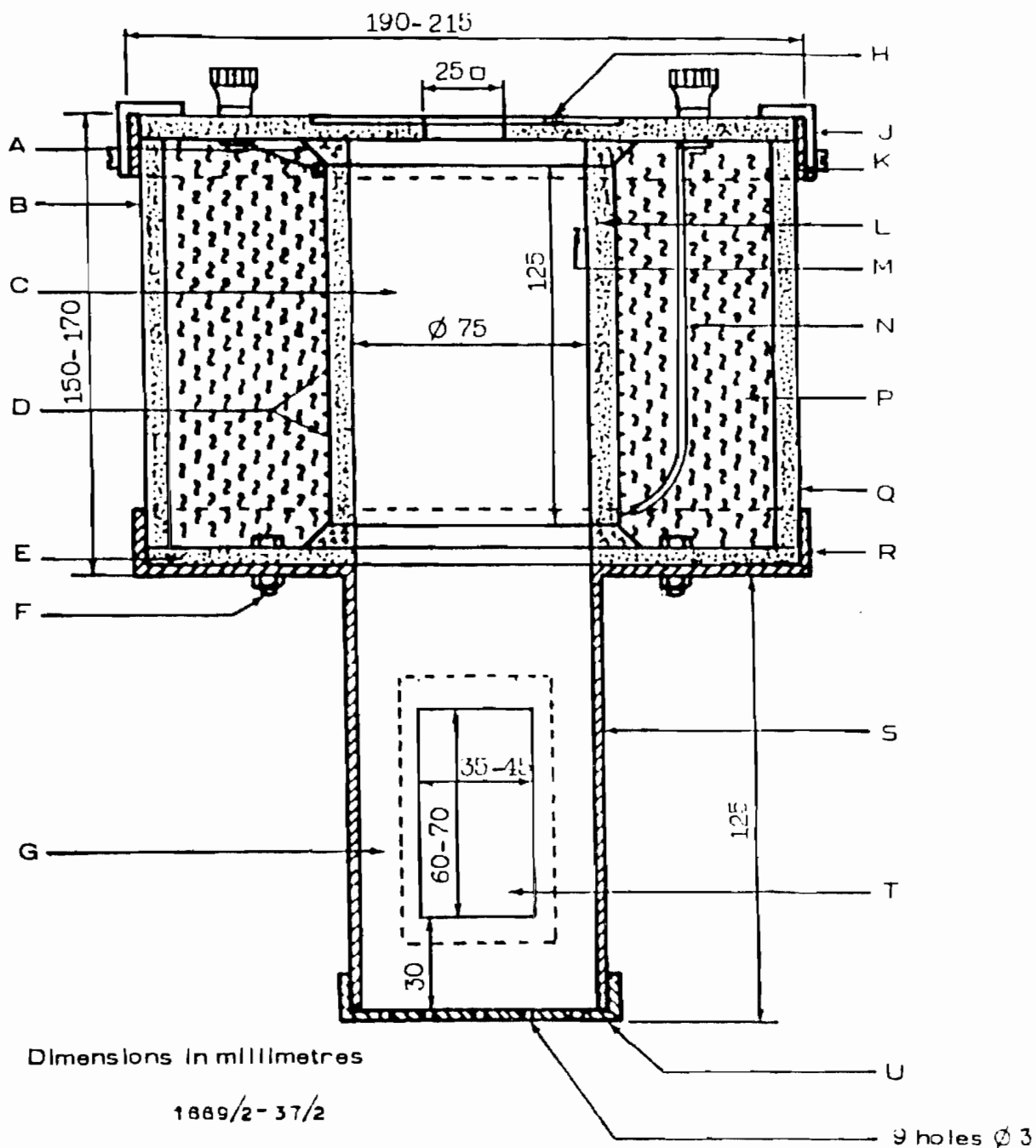

- | | |
|--|--|
| A - Refractory cement | K - Metal band |
| B - Asbestos cement sheet | L - Fireclay or silica tube |
| C - Heating chamber | M - Thermocouple |
| D - Nichrome element | N - Heat-resisting insulation |
| E - Asbestos board | P - Packing of asbestos wool
or magnesia asbestos |
| F - Brass bolt | Q - Asbestos cement sheet |
| G - Observation chamber | R - Angle Iron |
| H - Recess for placing
of conical cover | S - Metal cylinder |
| J - Metal clip | T - Mica window |
| | U - Screw-on or sliding-fit cap |

Fig. 7(b) - Details of Oven

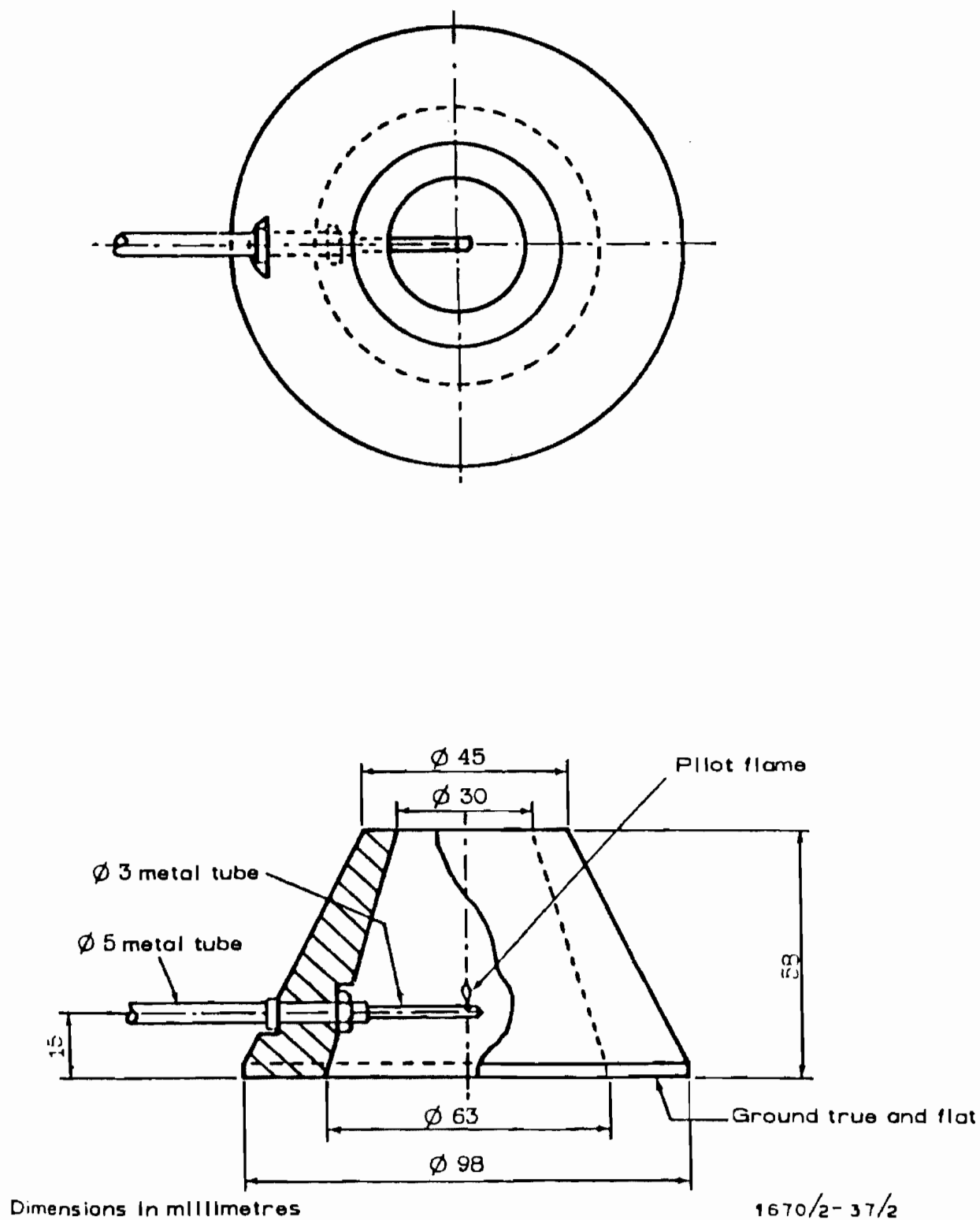

Fig. 7(c) - Details of Conical Cover

No. 2287

16 Oktober 1987

WET OP STANDAARDE, 1982

VERPLIGTE SPESIFIKASIE VIR STROOMBREKERS
MET GEVORMDE HULSE

Op aanbeveling van die Raad van die Suid-Afrikaanse Buro vir Standaarde en kragtens die bevoegdheid my verleen by artikel 16 (1) van die Wet op Standaarde, 1982 (Wet 30 van 1982), verklaar ek, Daniël Wynand Steyn, Minister van Ekonomiese Sake en Tegnologie, hierby die spesifikasie in die Bylae vervat tot 'n verpligte spesifikasie vir stroombrekers met gevormde hulse.

Die verpligte spesifikasie tree in werking op 'n datum twee maande na die datum van hierdie kennisgewing.

D. W. STEYN,

Minister van Ekonomiese Sake en Tegnologie.

No. 2287

16 October 1987

STANDARDS ACT, 1982

COMPULSORY SPECIFICATION FOR MOULDED-
CASE CIRCUIT-BREAKERS

On the recommendation of the Council of the South Africa Bureau of Standards and under the powers vested in me by section 16 (1) of the Standards Act, 1982 (Act 30 of 1982), I, Daniël Wynand Steyn, Minister of Economic Affairs and Technology, hereby declare the specification contained in the Schedule to be a compulsory specification for moulded-case circuit-breakers.

The Compulsory specification shall become operative on a date two months after the date of publication of this notice.

D. W. STEYN,

Minister of Economic Affairs and Technology.

BYLAE

VERPLIGTE SPESIFIKASIE VIR STROOMBREKERS MET GEVORMDE HULSE

1. BESTEK.

1.1 Hierdie spesifikasie dek een- en meerpolige lugbreekstroombrekers wat as 'n geïntegreerde eenheid gemonteer is in 'n gevormde huls van isoleermateriaal wat as steun en dekking dien, vir 'n stroomaanslag van hoogstens 1 000 A en vir 'n wisselspanning van hoogstens 1 000 V en 'n gelykspanning van hoogstens 500 V.

1.2 Hierdie spesifikasie dek nie kontaktors of motoraansitters en -reëlaars nie.

Opm.:

(a) Die spesifikasie dek veiligheidsvereistes vir stroombrekers wat in normale toestande gebruik word. Waar die toestande abnormaal is (bv. by die aanwesigheid van korroderende of plofbare dampe, stof, uiters hoë of lae temperature, uitermagtige vibrasie, hoë humiditeit en ander buitengewone werktoestande) moet raad ivm instalering en gebruik by die fabrikant of leweransier ingewin word.

(b) Die stroombrekers wat deur hierdie spesifikasie gedek word, is bedoel vir gebruik saam met kopergeleiers. Geleiers van ander materiaal kan gebruik word mits geskikte eindpunte beskikbaar is.

2. WOORDBEPALING.

2.1 Die volgende woordbepalings geld vir die doel van hierdie spesifikasie:

Aanneemlik: Aanneemlik vir die owerheid wat die spesifikasie administreer.

a-kontak: 'n Kontrolekontak of hulpkontak wat toe is as die hoofkontakte van die meganiese skakeltoestel toe is en oop is as hulle oop is.

b-kontak: 'n Kontrolekontak of hulpkontak wat oop is as die hoofkontakte van die meganiese skakeltoestel toe is en toe is as hulle oop is.

Breekvermoë: Die hoogste waarskynlike stroom wat die stroombreker volgens die fabrikant met welslae by die gespesifiseerde spanning in voorgeskrewe gebruiks- en gedragstoestande sal breek en sluit-en-breek.

Stroombreker: 'n Meganiese skakeltoestel wat strome in normale kringtoestande kan sluit, dra en breek en wat ook in gespesifiseerde abnormale kringtoestande soos dié wat tydens kortsluiting of by 'n aardfout voorkom, strome kan sluit, 'n gespesifiseerde tyd lank dra en kan breek.

Opm.: 'n Stroombreker is gewoonlik bedoel om nie dikwels te werk nie, hoewel sekere tipes geskik is om dikwels gebruik te word.

Tweepoolstroombreker: 'n Stroombreker met twee pole vir verbinding met die twee geleiers van 'n toevoerbren, waar elke pool voorsien is van een of meer verskillende uitklinkers en die pole (meganies) so gekoppel is dat hulle saam werk sodat die toevoer geïsoleer word indien 'n fout in *enigeen* van die pole voorkom.

Eenpool- en nulgeleierstroombreker: 'n Stroombreker met twee pole wat meganies so gekoppel is dat hulle saam werk en waarvan slegs een van een of meer verskillende uitklinkers voorsien is.

Eenpool- en skakelbeheerdnulgeleier-stroombreker: 'n Eenpoolstroombreker met 'n skakelbeheerde nulgeleier wat ontwerp is om saam met die pool van die stroombreker te werk en om voor die poolkontakte te sluit en na die poolkontakte te breek, met die doel om die nulgeleier te isoleer.

Eenpoolstroombreker: 'n Stroombreker met een pool wat van een of meer verskillende uitklinkers voorsien is.

Driepool- en nulgeleierstroombreker: 'n Stroombreker met vier pole waarvan drie van een of meer verskillende uitklinkers voorsien is, en waarin al die pole (meganies) so gekoppel is dat hulle saam werk sodat die toevoer geïsoleer word indien 'n fout in een of meer fases voorkom.

Opm.: Die drie pole wat van uitklinkers voorsien is, is bedoel om in die fasegeleiers van 'n driefasige vierdraadtoevoer en die vierde pool in die nulgeleier verbind te word.

Driepool- en skakelbeheerdenulegeleier-stroombreker: 'n Driepoolstroombreker met 'n skakelbeheerde nulgeleier wat ontwerp is om saam met die hoofpole van die stroombreker te werk en om voor die poolkontakte te sluit en na die poolkontakte te breek, met die doel om die nulgeleier in 'n driefasige vierdraadtoevoer te isoleer.

Driepoolstroombreker: 'n Stroombreker met drie pole wat elk van een of meer verskillende uitklinkers voorsien is en wat (meganies) so gekoppel is dat hulle saam werk.

Opm.: Hierdie toestel is bedoel vir gebruik in 'n driefasetoevoer waar beheer van die drie fases gelyktydig moet wees en waar 'n fout in een of meer fases sal veroorsaak dat die toevoer geïsoleer word.

Vry ruimte: Die kortste afstand, deur die lug gemeet, tussen twee geleidele.

Kruipafstand: Die kortste afstand, gemeet tussen twee geleidele, oor die oppervlak van isoleer-materiaal.

Opm.: 'n Las tussen twee stukke isoleermateriaal word as deel van die oppervlak beskou.

Stroom: In die geval van 'n wisselstroomkring, die waarde van die wortel van die gemiddelde kwadraat van die stroom.

Raamgrootte: 'n Term wat van toepassing is op 'n groep stroombrekers van dieselfde tipe en met dieselfde breekvermoë, wat fisies met mekaar uitruilbaar is en waarvan die grootte aangedui word deur die tipenommer en die hoogste stroomaanslag toegeken aan stroombrekers binne die groep.

Inherente terugkeertyd: Die tydsverloop tussen 'n oopmaakwerking in gespesifiseerde abnormale toestande en die geslaagde hersluiting van die stroombreker in normale toestande.

Pool: 'n Geleibaan in 'n stroombreker wat voorsien is van 'n stel kontakte wat die hoofstroomdeur die stroombreker dra, sluit en breek.

Kragfrekwensieherstelspanning: Die herstelspanning nadat die oorgangspanningsverskynsels verdwyn het.

Opm.: Die woordbepaling geld ook in die geval van gelykstroom, in welke geval daar geag word dat die frekwensie nul is.

Waarskynlike stroom: Die stroom(die gelykstroomof die WGK-waarde van die wisselkomponent van 'n wisselstroom) wat sal vloei by die sluiting van 'n kring waarin daar vir die invoeging van 'n stroombreker voorsiening gemaak is, indien 'n skakel met 'n onbeduidende impedansie ipv die stroombreker ingevoeg word. (In sommige kringe kan die skakel die AL-stroombreker en die verbindingsleidings van die toevoer af vervang.)

Aangeslane lasstroom: Die hoogste lasstroom, deur die fabrikant toegeken, wat die stroombreker ononderbroke teen die aangeslane spanning in gespesifiseerde toestande kan dra sonder om die gespesifiseerde temperatuurgrense te oorskry.

Opm.: Tensy anders vermeld, beteken die waarde van 'n wisselstroom 'n WGK-waarde en die waarde van 'n gelykstroom 'n gemiddelde waarde met 'n spanningsrimpel van hoogstens 4 %.

Aangeslane waarde: Die syferwaarde van 'n grootte (bv. spanning, stroom) wat in die aanslag ingesluit is en in die merke aangetoon word.

Aangeslane spanning: Die hoogste spanning, deur die fabrikant toegeken, waarteen die stroombreker gebruik kan word.

Opm.: Tensy anders vermeld, beteken die waarde van 'n WS-spanning 'n WGK-waarde en die waarde van 'n GS-spanning 'n gemiddelde waarde met 'n spanningsrimpel van hoogstens 4 %.

Herstelspanning: Die spanning wat oor die aansluiters van 'n pool van 'n stroombreker voorkom nadat die stroom gebreek is.

Opm.: Hierdie spanning kan gedurende twee opeenvolgende tydperke oorweeg word, een waartydens oorgangspanning bestaan, gevolg deur 'n tweede waartydens slegs kragfrekwensiespanning bestaan.

Uitklinker:

Nie-vertragings(oorstroom)uitklinker: 'n Uitklinktoestel sonder enige opsetlik vertraagde werking.

Oorstroomuitklinker: 'n Uitklinker wat 'n stroombreker met of sonder vertraging laat breek wanneer die stroom in die uitklinker 'n voorafbepaalde waarde oorskry.

Paralleluitklinker: 'n Uitklinkspoel wat van die hoofkring of van 'n afsonderlike hulptoevoer deur 'n relê, skakelaar of ander middele bekrag word.

Vertragings(oorstroom)uitklinker: 'n Uitklinktoestel met opsetlik vertraagde werking.

Onderspanningsuitklinker: 'n Uitklinker wat 'n stroombreker met of sonder vertraging laat breek wanneer die spanning oor die aansluiters van die uitklinker onder 'n voorafbepaalde waarde val en wat die stroombreker laat sluit wanneer die spanning oor die aansluiters 'n voorafbepaalde waarde oorskry.

Soliede nulgeleier: In 'n stroombreker, 'n geleibaan wat nie van 'n stel kontakte voorsien is nie en waarvan een ent met die inkomende nulbaan en die ander ent met die uitgaande nulbaan verbind is.

Skakelbeheerde nulgeleier: Twee kontakte in 'n geleibaan, gewoonlik by of naby aardpotensiaal, wat die aangeslane stroom van die stroombreker kan dra en wat ook 'n gespesifiseerde tyd lank 'n stroom in gespesifiseerde abnormale kringtoestande (bv. dié wat tydens kortsluiting voorkom) kan dra, maar wat nie ontwerp is om strome deur die kring te sluit of te breek nie.

Oorgangherstelspanning (OHS): Die herstelspanning gedurende die tydperk waarin dit wesenlik oorganklik van aard is.

Opm.:

(a) Die oorgangherstelspanning kan ossillerend of nie-ossillerend of 'n kombinasie hiervan wees, na gelang van die kring- en stroombrekereienskappe. Dit sluit die spanningsverskuiwing van die nulgeleier van 'n veelfasekring in.

(b) Tensy anders vermeld, is die oorgangherstelspanning in drie-fasekringe die spanning oor die eerste pool wat oopmaak omdat hierdie spanning gewoonlik hoër is as dié wat oor elk van die ander twee pole voorkom.

Vryuitklinkstroombreker: 'n Stroombreker waarin die outomatiese uitklinkmeganisme die kontakte van die stroombreker in fouttoestande sal oopmaak, onafhanklik van die middele wat gebruik word om die kontakte te sluit, en wat sal verseker dat die kontakte nie gesluit gehou word in 'n toestand waarin uitklinking moet voorkom nie.

Uitklinking: Die oopmaak van 'n stroombreker, met die hand of outomaties.

Uitklinktyd: Die tydsverloop tussen die aanlê van 'n bestendige oorstroom en die onderbreking van die kring.

Spanning: In die geval van 'n wisselstroomkring, die waarde van die wortel van die gemiddelde kwadraat van die spanning.

3. ONTWERP EN KONSTRUKSIE.

3.1 **STANDAARD VAN VAKMANSKAP EN AFWERKING:** Alle werk moet behoorlik uitgevoer en afgewerk wees en moet so gerangskik wees dat dit geen gevaar inhou nie.

3.2 **GEVORMDE HULS:** Die werkmeganisme van 'n stroombreker moet omhul wees deur 'n gevormde huls wat gemaak is van nie-brandbare isoleermateriaal wat geen vlamme of gesmelte metaal deur die openinge om die werkhefboom sal deurlaat nie.

3.3 BESKERMING.

3.3.1 Lewendige dele van 'n stroombreker wat vir oppervlakmontering bedoel is, moet deur isoleermateriaaldeksels van aanneemlike sterkte teen onopsetlike aanraking beskerm wees.

3.3.2 Lewendige dele aan die onderkant van 'n stroombreker wat vir oppervlakmontering ontwerp is, moet—

(a) met 'n skerm of versperring van isoleermateriaal bedek wees; of

(b) minstens 3 mm onder die oppervlak van die voetstuk versink wees en bedek wees met 'n waterdigte isoleerseëlmiddel wat nie tydens enige van die toetse in Afdeling 6 gespesifiseer, sal vloei nie; of

(c) 'n minimum vry ruimte van 6 mm van die monteerooppervlak af wees en vasgeklank, gestuik of op ander betroubare wyse bevestig wees sodat dit nie kan losraak nie.

3.4 **VRY RUIMTES EN KRUIPAFSTANDE:** Alle vry ruimtes en kruipafstande moet so groot moontlik wees en om die deurlopendheid van geleidende neerslag wat moontlik kan vorm te breek, moet kruipafstande, waar moontlik, groewe bevat.

3.5 **MONTERING:** Elke stroombreker moet minstens twee gate vir monteersdoeleindes hê of daar moet voorsiening gemaak wees vir 'n ander montermetode wat aanneemlike stabiliteit sal verseker.

3.6 BEDIENINGSMETODE.

3.6.1 'n Stroombreker moet vir sluit en oopmaak met die hand en vir outomatiese uitklinking ontwerp wees. Die meganisme moet van die vryuitklinktipe wees.

- 3.6.2 Die aktueermeganisme moet sodanig wees dat, as 'n stroombreker op normale wyse gemonteer is, die kontakte nie vanself as gevolg van faling van die meganisme kan sluit nie.
Opm.: Daar word geag dat 'n stroombreker op normale wyse gemonteer is as dit op 'n vertikale vlak gemonteer is met die hoofas vertikaal of horisontaal.
- 3.6.3 Die uitklinking van 'n stroombreker in watter toestand binne sy aanslagbestek ook al, mag nie tot gevolg hê dat die kontakte wat die kring breek, wip of 'n neiging toon om weer te sluit nie.
- 3.7 BOOGSKERMS: Midde moet voorsien word om te verseker dat, wanneer 'n meerpoolstroombreker werk, daar geen oorvonking tussen die pole is nie.
- 3.8 AANDUI VAN UITKLINKING: 'n Stroombreker moet so ontwerp wees dat, as dit uitgeklink het, 'n duidelike aanduiding te dien effekte vir die gebruiker sigbaar is.
- 3.9 AANSLUITERS.
- 3.9.1 'n Stroombreker moet voorsien wees van geskikte aansluiters vir die verbinding van kopergeleiers van die grootte wat in kolom 2 van Tabel 1 teenoor die stroomaanslag van die stroombreker aangegee word. Die aansluiters van 'n stroombreker met 'n tussenstroomaanslag moet geleiers met die nominale dwarsnoppervlakte gespesifiseer vir die volgende hoër stroomaanslag kan neem.

TABEL 1—BEDRADINGSAANSLUITERS (KOPERGELEIERS)

1		2
Aangeslane stroom van stroombreker, A		PVC-bedekte kopergeleier, getal en nominale dwarsnoppervlakte, mm ² , min
Deel 1		
Hoogstens	10	2 × 1,5
	16	2 × 4,0
	20	2 × 4,0
	25	2 × 4,0
	31,5	2 × 6,0
	40	10,0
	50	16,0
	63	25,0
	80	35,0
	100	50,0
	125	70,0
	160	95,0
	180	95,0
	200	120
Aangeslane stroom van stroombreker, A		Reghoekige stawe, afgewerk in matswart, getal en afmetings, mm, min*
Deel 2		
Tot en met	244	2 × (4 × 16)
	250	2 × (4 × 16)
	315	2 × (5 × 20)
	355	2 × (5 × 25)
	400	2 × (5 × 31,5)
	500	2 × (5 × 40)
	630	2 × (5 × 50)
	710	2 × (5 × 63)
	800	2 × (15 × 80)
	1 000	2 × (5 × 80)

* Die spasiëring tussen twee parallelle stawe met dieselfde polariteit moet ongeveer 5 mm wees.

Indien 'n enkele verbinding met twee parallelle stawe vereis word, moet die ruimte tussen die twee stawe gepak wees met koper wat 5 mm dik is en waarvan die breedte en lengte gelyk is aan die breedte van die twee stawe.

Indien die stawe nie by die aansluiters van die stroombreker pas nie, moet die afmetings van 'n kopertussenverbindingstuk (wat PVC-bedekte koperkabel kan wees) deur die fabrikant verskaf word.

- 3.9.2 Aansluiters moet so ontwerp wees dat hulle nie toelaat dat die geleiers verplaas word of dat die aansluiters self verplaas word op so 'n wyse dat die werking van die stroombreker of die doeltreffendheid van die isolasie nadelig beïnvloed word nie [d.w.s. die minimum voorgeskrewe waardes vir vry ruimtes en kruipafstande in 3.3.2 (b) en (c) gespesifiseer, moet in alle normale werktoestande van die stroombreker gehandhaaf word].
- 3.9.3 Elke aansluiter vir die verbinding van 'n buitegeleier moet so ontwerp wees dat dit maklik toeganklik is in die bedoelde gebruikstoestande en daarbenewens moet 'n aardaansluiter (indien een aangebring is)—
- (a) op geskikte wyse teen korrosie beskerm wees;
 - (b) blywend en onuitwisbaar met die simbool \oplus gemerk wees; en

(c) van sodanige grootte wees dat dit 'n geleier sal neem wat aan die bepalings vir aardkontinuiteitsgeleiers van SABS 0142 'Die bedrading van persele' voldoen.

- 3.9.4 'n Bedradingsaansluiter hoef nie sodanig te wees dat dit 'n geleier regstreeks neem nie, d.w.s. sonder dat 'n geskikte eindpunt aan die geleier aangebring word, maar indien 'n aansluiter bedoel is om 'n stringgeleier te neem, moet middele voorsien wees om te verhoed dat die geleierdrade oopsprei.
- 3.9.5 Elke bedradingsaansluiterskroef moet in metaal inskroef en 'n gladde, netjies gesnyde draad vry van brame hê. Die punt van die skroef moet so gevorm wees dat dit nie die geleier sal beskadig nie. Behalwe soos hieronder toegelaat, mag geen yster of staal vir aansluiters gebruik word nie, tensy dit aanwesig is as bestanddeel van 'n legering wat inherent korrosiebestand is.
- 3.9.6 Aansluiters van die tipe waarin die buiteverbindinggeleiers regstreekse elektriese kontak met die pool van 'n stroombreker maak en waarop daar nie staat gemaak word om die hoofstroom van die stroombreker te dra nie, kan van yster of staal wees wat op aanneemlike wyse met koper, nikkell, kadmium, silwer of sink geplaatser is.
- 3.10 AARDING: Daar moet voorsiening gemaak word vir die aarding van enige oop metaaldele van 'n stroombreker wat lewendig kan word indien die isolasie van enige deel van die stroombreker onklaar raak (kyk ook 3.9.3).

TABEL 2—GELEIERGROOTTES VIR TEMPERAATUURSTYG- EN OORSTROOMUITKLINKTOETS (KOPER)

1		2
Aangeslane stroom van stroombreker, A		Nominale dwarsnoppervlakte van geleier, mm ²
Deel 1		
Hoogstens	10	1,5
	16	2,5
	20	2,5
	25	4
	31,5	6
	40	10
	50	10
	63	16
	80	25
	100	35
	125	50
	160	70
	180	70
	200	95
	224	120
	250	150
	315	185
	355	240
Aangeslane stroom van stroombreker, A		Reghoekige stawe, getal en afmetings, mm*
Deel 2		
Hoogstens	400	2 × (31,5 × 5)
	500	2 × (40 × 5)
	630	2 × (50 × 5)
	710	2 × (63 × 5)
	800	2 × (80 × 5)
	1 000	2 × (80 × 5)

* Die spasiering tussen twee parallelle stawe met dieselfde polariteit moet ongeveer 5 mm wees.
 Indien 'n enkele verbinding met twee parallelle stawe vereis word, moet die ruimte tussen die twee stawe gepak wees met koper wat 5 mm dik is en waarvan die breedte en lengte gelyk is aan die breedte van die twee stawe.
 Indien hierdie stawe nie by die aansluiters van die stroombreker pas nie, moet die afmetings van 'n kopertussenverbindingstuk (wat PVC-bedeekte koperkabel kan wees) deur die fabrikant verskaf word.

4. ELEKTRIESE EN FISIESE VEREISTES.

4.1 AANSLAG: Die aanslag van elke stroombreker moet op grond van spanning, stroom, breekvermoë en getal pole bepaal wees.

(a) Die breekvermoë van 'n stroombreker wat met WS gebruik word, moet 2,5 kA of 20 maal die waarde van die aangeslane stroom wees, wat ook al die grootste is. 'n Stroombreker wat bedoel is vir gebruik met WS sowel as GS, moet twee aangeslane waardes vir breekvermoë hê, nl een vir WS en een vir GS.

(b) Tensy 'n ander frekwensie op die stroombreker aangegee is, moet die frekwensie van 'n WS-stroombreker 50 Hz wees.

- (c) 'n Stroombreker moet 'n eenpool-, tweepool- of driepool-stroombreker wees en kan, indien dit vereis word, 'n nulgeleierpool of 'n skakelbeheerde nulgeleier hê.
- 4.2 ISOLASIEWEERSTAND: Volgens 6.3 bepaal, moet die isolasieweerstand van 'n stroombreker minstens 10 MΩ wees.
- 4.3 ONDERSPANNINGSUITKLINKER.
- 4.3.1 Indien dit vereis word, moet 'n stroombreker van 'n onderspanningsuitklinker voorsien wees.
- 4.3.2 Volgens 6.4 getoets, moet 'n stroombreker wat van 'n onderspanningsuitklinker voorsien is, by 'n waarde van tussen 70 % en 35 % van die aangeslane spanning van die onderspanningsuitklinker oopmaak, selfs al daal die spanning stadig (1 % per sekonde). Die onderspanningsuitklinker moet verhoed dat die stroombreker by 'n spanning van minder as 35 % van die aangeslane spanning van die onderspanningsuitklinker sluit en mag nie verhoed dat dit by 85 % of hoër van die aangeslane spanning van die onderspanningsuitklinker sluit nie.
- 4.4 PARALLELUITKLINKER.
- 4.4.1 Indien dit vereis word, moet 'n stroombreker voorsien wees van 'n spanningsbeheerde paralleluitklinker met 'n spesifieke spanningsaanslag of spanningsaanslagbestek.
- 4.4.2 Volgens 6.5 getoets, moet 'n stroombreker wat van 'n spanningsbeheerde paralleluitklinker voorsien is, by 70 % sowel as 120 % van die aangeslane spanning van die paralleluitklinker werk.
- 4.5 OORSTROOMUITKLINKER.
- 4.5.1 *Algemeen:*
- 4.5.1.1 Indien dit vereis word, moet 'n stroombreker van 'n oorstroomuitklinker voorsien wees.
- 4.5.1.2 Die oorstroomuitklinker moet van 'n verstelbare of nie-verstelbare vertragingstipe, of 'n nie-vertragingstipe wees.
- 4.5.1.3 Die stroom-tydken-kromme van 'n stroombreker moet dié wees wat die fabrikant daaraan toegeken het en wat op die stroombreker aangegee is [kyk 5.1 (k)].
- 4.5.2 *Vertragingstipe:*
- 4.5.2.1 'n Stroombreker met 'n nie-verstelbare vertragingsuitklinker moet die aangeslane stroom daarvan deurlopend dra sonder om uit te klink, maar moet, volgens 6.6 getoets, outomaties uitklink binne die tydperke wat in Tabel 3 teenoor die aangeslane stroom van die stroombreker aangegee word.
- 4.5.2.2 'n Verstelbare vertragingsuitklinker moet sodanig wees dat die stroombreker by die maksimum instelling daarvan aan die vereistes van 4.5.2.1 sal voldoen.
- 4.5.3 *Nie-vertragingstipe:* 'n Stroombreker met 'n nie-vertragingsuitklinker moet die aangeslane stroom daarvan deurlopend dra sonder om uit te klink en indien 135 % van die aangeslane stroom aangelê word, moet dit onmiddellik uitklink en moet die boog binne 0,1 sekonde uitgedoof wees.

TABEL 3—WERKING VAN OORSTROOMUITKLINKER

1	2	3	4	5	6	7
Aangeslane stroom (I), A	Uitklynktyd, maks					
	Persentasie aangeslane stroom					
	135	200	400	600	1 000	2 000
I ≤ 40	50 min	3 min	25 s	10,0 s	3,5 s	1,0 s
40 < I ≤ 80	100 min	4 min				
80 < I ≤ 125	100 min	6 min				
125 < I ≤ 225	100 min	8 min	Soos deur die fabrikant aangegee.			
225 < I ≤ 400	100 min	10 min				
400 < I ≤ 630	100 min	12 min				
630 < I ≤ 800	100 min	14 min				
800 < I ≤ 1 000	100 min	16 min				

- 4.6 OORBELASTING: Volgens 6.7 getoets, mag 'n stroombreker geen teken van elektriese of meganiese falings toon nie en mag daar geen smelting, oormatige verbranding of invreting by die kontakte voorkom nie.
- 4.7 TEMPERATUURSTYGING: Volgens 6.8 bepaal, mag die temperatuurstyging van die isoleermateriaal en van elke deel van 'n stroombreker nie die toepaslike waarde in Tabel 4 oorskry nie.

TABEL 4—TEMPERATUURSTYGING

1	2
Dele en tipe materiaal*	Temperatuur- styging, °C, maks
(a) Bedradingsaansluiters	70
(b) Kontakte:	
koper of koperlegering	45
silwer	†
silwer-wolfram en ander sintermetaal	‡
(c) Katoen, sy, papier en soortgelyke materiaal, nie geïmpregneer nie	65
(d) Katoen, sy, papier en soortgelyke materiaal, met geskikte hars geïmpregneer, en emalje indien dit saam met sodanige materiaal gebruik word	80
(e) Draad bedek met formaldehid-, poliviniel- of epoksihars of poliuretaan indien hulle nie saam met veselmateriaal gebruik word nie	95
(f) Fenolsamestelling as elektriese isolasie gebruik	§80
(g) Mika, glasvesel of asbes met bindmiddel en geïmpregneer	105
(h) Onbedekte spoele	90
(i) Werkhefbome (handbedien)	25

* Ander materiaal wat nie in hierdie tabel ingesluit is nie, word aanneemlik geag indien daar bewys is dat sodanige materiaal sonder nadelige gevolge gebruik kan word by die temperature wat tydens die dienstoestande bereik word.

† Slegs beperk omdat dit noodsaaklik is dat aanliggende dele nie beskadig word nie.

‡ Moet gespesifiseer word volgens die eienskappe van die metaal wat gebruik word en word beperk omdat dit noodsaaklik is dat aanliggende dele nie beskadig word nie.

§ Tensy daar vasgestel is dat die materiaal vir gebruik by hoër temperature aanneemlik is.

4.8 MEGANIESE STERKTE: Volgens 6.10 getoets, mag 'n stroombreker geen teken van barste of permanente vervorming toon nie.

4.9 BREEKVERMOË.

4.9.1 (a) 'n WS-stroombreker moet 'n kring, ingestel vir die waarskynlike stroom met die toepaslike drywingsfaktor in Tabel 6 teenoor die breekvermoë van die stroombreker aangegee, een maal kan breek en een maal kan sluit-en-breek.

(b) 'n GS-stroombreker (klas SABS 1,5 kA) moet 'n GS-kring met 'n totale induktansie van $1 \pm 0,15$ mH en 'n waarskynlike stroom van 1 500 A een maal kan breek en een maal kan sluit-en-breek.

(c) Die inherente terugkeertyd van 'n stroombreker mag nie 15 minute oorskry nie.

4.9.2 By die toets van 'n stroombreker volgens 6.9—

(a) mag dit geen tekens van elektriese of meganiese faling toon nie;

(b) mag die kaasdoek wat oor die werkhefbome geplaas is, nie aan die brand slaan nie;

(c) moet die gemiddelde waarde van die kragfrekwensieherstelspanning gelyk wees aan 'n waarde wat ooreenstem met 110 % van die aangeslane werkspanning [kyk 6.9.1 (c)] wat net voordat die toetsstroom begin vloei, oor die aansluiters van 'n pool van die stroombreker voorkom en hierdie spanning moet minstens 0,1 sekondes lank volgehou word nadat die boog uitgedoof is;

Opn.: Dit mag dit nodig maak dat die aangelegde spanning verhoog moet word, maar die toleransie op die waarskynlike spitsluitstroom mag nie sonder die toestemming van die fabrikant oorskry word nie.

(d) mag daar geen beskadiging plaasvind aan die isolasie van geleiers wat gebruik word om die stroombreker in die kring te verbind nie;

(e) mag die sekering wat metaaldele met die nulgeleier van die WS-kragtoevoer of met die negatiewe pool van die GS-kragtoevoer verbind, nie deurslaan nie;

(f) moet die stroombreker steeds aan die vereistes van 4.5.2 vir werking by 200 % van die aangeslane stroom of van 4.5.3, soos toepaslik, voldoen; en

- (g) moet die stroombreker steeds 'n toetsspanning van die grootte wat in Tabel 7 teenoor die aangeslane spanning van die stroombreker aangegee word, een minuut lank sonder deurslag kan deurstaan.
- 4.10 NIE-BRANDBAARHEID: Volgens 6.12 getoets, mag materiaal wat nie-brandbaar moet wees, nie brand of vlambare dampe afgee nie.
5. MERKE.
- 5.1 STROOMBREKERS: Die volgende besonderhede moet leesbaar en onuitwisbaar op óf die romp van die stroombreker óf op 'n etiket (kyk 5.3) wat stewig daaraan bevestig is, soos toepaslik, aangebring wees in een of albei amptelike tale van die Republiek van Suid-Afrika (tensy daar anders vereis word):
- (a) Die aangeslane stroom (I_n);
 - (b) die "AAN"- en "AF"-posisie van die stroombreker, op die werkhefboom of op die huls, op een van die volgende wyses:
 - (i) Die simbole | en O onderskeidelik vir die "AAN"- en "AF"-posisie, of
 - (ii) die woorde "AAN" en "AF" ("ON" en "OFF") in albei amptelike tale;

Opm.:

 - (i) Die "AAN"- of | -merk moet aandui dat die skakelaar in die boonste posisie is;
 - (ii) die simbool | wat vir die "AAN"-posisie gebruik word, moet 'n regop reguit lyn wees, nie 'n l of I nie.

Opm.: Die operateur moet bogemelde merke [(a) en (b)] duidelik kan sien wanneer die stroombreker soos vir normale diens gemonteer is. Indien die merke op die huls of deksel van die stroombreker aangebring is, moet hulle langs die werkhefboom en sigbaar wees as die hefboom in die toepaslike posisie is. Indien die merke op deksels aangebring is, moet die deksels nie-omkeerbaar wees.
 - (c) die aangeslane spanning;
 - (d) die frekwensie-aanslae (indien toepaslik);
 - (e) ðf—
 - (1) "WS" (of "∼") indien die stroombreker slegs vir gebruik by WS bedoel is, ðf
 - (2) "GS" (of "=") indien die stroombreker slegs vir gebruik by GS bedoel is, ðf
 - (3) altwee merke in (1) en (2) hierbo aangegee, saam met die toepaslike spanningsaanslae, indien die stroombreker vir gebruik by GS sowel as WS bedoel is;
 - (f) indien toepaslik, die spanningsaanslag en die stroomaanslag of VA-aanslag van die paralleleutklinker, onderspanningsuitklinker, hulp- en alarmkakelaar, ens;
 - (g) die fabrikant of leweransier se naam, handelsnaam of geregistreerde handelsmerk;
 - (h) 'n katalogusnommer, tipenommer of ander identifikasie-merk wat die stroombreker onderskei van enige ander tipe stroombreker wat die fabrikant bemark;
 - (i) in die geval van 'n stroombreker wat van nulgeleierkontakte voorsien is, die letter N om die nulgeleieraansluiting te identifiseer;
 - (j) die breekvermoëklas (in kiloampère) waartoe die stroombreker behoort en, in die geval van 'n stroombreker met meer as een aangeslane breekvermoë, die aangeslane spanning vir elke breekvermoëklas;
 - (k) die stroom-tydkenkromme (hierdie merk kan 'n kodemerk wees en geld slegs vir 'n stroombreker wat van 'n oorstroomuitklinker voorsien is);
 - (l) 'n aanneemlike identifikasie-merk vir die lyn- en lasaansluiters of, so nie, rigtingspyle wat die ingang- en uitgangrigting van die toevoerverleidings aandui indien omgekeerde verbinding die werkverrigting van die stroombreker beïnvloed;
 - (m) indien die stroombreker bedoel is om dikwels gebruik te word (waar die stroomaanslag 31,5 A of minder is), die simbool "FO".
- 5.2 Die toepaslike van die volgende simbole kan ook leesbaar en onuitwisbaar op die romp van die stroombreker aangebring word:

I_n = aangeslane stroom

U_n = aangeslane spanning

I_{cn} = aangeslane breekvermoëklas, bv " I_{cn} 2,5 kA" termiese, magnetiese eenpoolstroombreker



termiese, magnetiese eenpoolstroomverbreker



magnetiese eenpoolstroombreker



termiese, magnetiese driepoolstroombreker

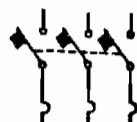

magnetiese driepoolstroombreker



eenpool- en nulgeleierstroombreker



eenpool- en skakelbeheerdenuolgeleier-stroombreker

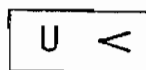

onderspanningsrelé

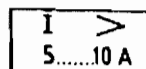

oorstroomrelé met 'n stelbestek van 5 A tot 10 A

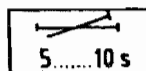

tydvertraging stelbaar van 5 sekondes tot 10 sekondes



paralleluitklinker



a-hulpkontak



b-hulpkontak

- 5.3 **ETIKETTE:** Etiket (indien hulle gebruik word) moet van aanneemlike materiaal wees en by die toets daarvan volgens 6.11, moet die merke steeds leesbaar wees. In die geval van 'n kleefetiket, mag dit nie moontlik wees om die etiket in een stuk te verwyder nie.
- 5.4 **AARDAANSLUITERS:** Die simbool \oplus moet blywend en onuitwisbaar op elke aardaansluiter aangebring wees.
6. **ONDERSOEK EN TOETSMETODES.**
- 6.1 **ONDERSOEK:** Ondersoek elke stroombreker visueel en meet dit, indien toepaslik, vir voldoening aan die toepaslike vereistes van die spesifikasie (soos in Afdeling 3, 4 en 5 aangegee) waarvoor toetse vir die beoordeling van voldoening nie in 6.2 tot en met 6.12 aangegee word nie.
- 6.2 **ALGEMEEN:** Voer in die geval van driepoolstroombrekers wat van 'n nulgeleierpool of 'n skakelbeheerdenuleleier-pool voorsien is, elke toets uit met die eenhede as tweepoolstroombrekers verbind, met die nulgeleierpool en die aanliggende pool as die pole wat getoets word. Gebruik 'n toetsspanning gelyk aan die fasespanning wat met die aangeslane spanning ooreenstem.
- 6.2.1 Tensy daar anders vereis word, voer die toetse op elke stroombreker in sy geheel uit by 'n omgewingstemperatuur wat by 15–25 °C gehou word.
- 6.2.2 Toets elke eenpool- en skakelbeheerdenuleleier-stroombreker, en elke eenpool- en nulgeleierstroombreker soos 'n tweepoolstroombreker.
- 6.2.3 Met uitsondering van die lugkernreaktor in enige fase (wat omtak moet word deur middel van 'n weerstand van sodanige waarde dat die stroom deur die resistor 0,6–0,7 % van die stroom deur die lugkernreaktor is), moet die reaktansie- of weerstandskomponente van die lasimpedansie van 'n toetskring nie parallel verbind word nie.
- 6.2.4 Gebruik, tensy daar anders gespesifiseer word, 'n wisselstroomtoevoer wat wesenlik sinusgolvormig is en 'n frekwensie van 50 ± 2 Hz het, vir die toets. Die volgende algemene toleransies geld vir alle toetse waarby geen toleransies aangegee word nie:
- Spanning ± 5 %; stroom ± 5 %; frekwensie ± 2 Hz; tyd ± 5 %.
- 6.3 **ISOLASIEWEERSTANDSTOETS:** Meet die isolasieweerstand by 'n GS-spanning van 500 V op die volgende plekke:
- (a) Tussen lewendige aansluiters en enige metaaldele wat oop sal wees as die stroombreker in die normale posisie gemonteer is. Voer hierdie toets uit (met alle oop metaaldele elektries met mekaar verbind) met die stroombreker eers in die "AAN"-posisie en dan in die "AF"-posisie;
- (b) in die geval van meerpoolstroombrekers—
- (1) tussen elke twee pole met die stroombreker in die "AAN"-posisie,
- (2) tussen elke inkomende en elke uitgaande aansluiter, met die stroombreker in die "AF"-posisie, en met 'n elektriese tussenverbinding tussen—
- (i) alle inkomende aansluiters; en
- (ii) alle uitgaande aansluiters.
- Gaan na vir voldoening aan 4.2.
- 6.4 **ONDERSPANNINGSUITKLINKTOETS:** Verbind die onderspanninguitklinker met 'n kragtoevoer wat teen die aangeslane spanning daarvan werk. Verminder die spanning teen 'n tempo van 1 % per sekonde totdat die stroombreker uitklink, en teken die spanning op hierdie punt aan. Stel die spanning in op 34 % van die aangeslane spanning en sluit die stroombreker. Stel die spanning in op 85 % van die aangeslane spanning, sluit die stroombreker en stel vas of dit by hierdie spanning gesluit bly of nie. Gaan na vir voldoening aan 4.3.2.
- 6.5 **PARALLELUITKLINKTOETS:** Verbind die stroombreker met die kragtoevoer en stel vas of die stroombreker uitklink wanneer die paralleluitklinker bekrag word by 'n toevoerspanning van—
- (a) 70 %, en
- (b) 120 %
- van die aangeslane spanning. Gaan na vir voldoening aan 4.4.2.
- 6.6 **OORSTROOMUITKLINKTOETS.**
- 6.6.1 **Montering en verbindings:** Monteer die stroombreker soos vir normale diens (met al die deksels in posisie) en verbind dit met die kragtoevoer deur middel van geleiers met 'n lengte van minstens 1 m en van die grootte in Tabel 2 aangegee teenoor die stroomaanslag van die stroombreker.

6.6.2 Procedure:

(a) Gebruik enige gerieflike spanning en bepaal die stroomtydkenkromme van die stroombreker deur dit by 'n omgewingstemperatuur van $25 \pm 5^\circ\text{C}$ teen al die volgende persentasies van die aangeslane stroom te laat werk:

135	1 000
200	2 000
400	

Toets elke pool wat van 'n oorstroomuitklinker voorsien is afsonderlik, maar vir kalibrering teen 135 % van die aangeslane stroom moet alle pole gelyktydig en met 'n gelyke belasting getoets word. Gaan na vir voldoening aan 4.5.1.3.

Opm.: Indien die kenkromme van 'n stroombreker van so 'n aard is dat bogemelde punte nie 'n gladde kromme gee nie, kan bykomende punte tussenin geneem word waar dit nodig geag word.

(b) Gaan ten slotte die stroomaanslag na deur die stroombreker minstens twee uur lank teen die aangeslane stroom daarvan deur al die pole gelyktydig te laat werk.

6.7 OORBELASTINGTOETS.

6.7.1 **Toetskring:** Monteer die stroombreker soos vir normale diens en verbind dit in 'n kring waarin die stroom op $600 \pm 5\%$ van die toepaslike aangeslane waarde en die aangelegde spanning op $110 \pm 5\%$ van die aangeslane spanning van die stroombreker ingestel is. Gebruik vir stroombrekers, uitgesonderd dié wat slegs vir gebruik met WS bedoel is, 'n GS-kring met 'n totale inductansie van $1 \pm 0,15$ mH aan die belastingkant, en vir stroombrekers wat slegs vir gebruik met WS bedoel is, 'n WS-kring met 'n naloopdrywingsfaktor van 0,45–0,5.

6.7.2 **Procedure:** Tensy daar anders vereis word, laat die stroombreker 50 maal opeenvolgend sluit en breek teen die toepaslike tempo in kolom 2 van Tabel 5 aangegee en maak seker dat die kontakte in elke siklus hoogstens twee sekondes lank gesluit bly. Toets, in die geval van meerpoolstroombrekers, al die pole wat bedoel is om stroom te onderbreek gelyktydig, terwyl elke pool die stroom dra wat hierbo gespesifiseer word. Voer die toets uit soos hierbo beskryf in die geval van 'n stroombreker sonder 'n oorstroomuitklinker maar met 'n paralleluitklinker, maar bekrag die uitklinker só (deur 'n spanning gelyk aan die aangeslane spanning van die uitklinker aan te lê) dat die stroombreker 20–40 millisekondes nadat dit gesluit is, oopmaak.

Gaan na vir voldoening aan 4.6.

TABEL 5—WERKSIKLUSTEMPO

1	2
Stroomaanslag (binne die toepaslike raamgrootte), A	Werktempo, siklusse/ minuut
Tot 100	6
101–224	5
225–630	4
631–1 000	2

6.8 **TEMPERATUURSTYGTUETS:** Monteer die stroombreker soos vir normale diens (met al die deksels in posisie) op 'n plek waar daar geen trek is nie en waar die omgewingslugtemperatuur $25 \pm 5^\circ\text{C}$ is. Gebruik geleiers met 'n lengte van minstens 1 m elk en van die grootte wat in Tabel 2 teenoor die stroomaanslag van die stroombreker aangegee word, en verbind die stroombreker met die kragtoevoer. Stuur die aangeslane stroom twee uur lank, of totdat termiese ewewig bereik is, deur die stroombreker. Meet dan die toepaslike temperatuur (kyk Tabel 4) deur middel van termokoppels of volgens enige ander aanneemlike metode op die plekke waar daar geoordeel word dat die temperatuur na vermoede die hoogste is. Gaan na vir voldoening aan 4.7.

6.9 BREEKVERMOËTUETS.**6.9.1 Kragtoevoer:**

(a) **Wisselstroom:** 'n Bron wat $100 \pm 5\%$ van die toepaslike waarskynlike stroom by die ooreenstemmende naloopdrywingsfaktor soos aangegee, kan verskaf. Enige stroombegrensimpedansie wat gebruik word, word tussen die stroombreker en die kragtoevoer geplaas.

(b) **Gelykstroom:** 'n Bron wat die waarskynlike stroom van 1 500 A in 'n kring met 'n totale inductansie van $1 \pm 0,15$ mH kan verskaf.

(c) **Spanning:** Die spanning van die toetskring onmiddellik voordat die toetsstroom begin vloei, moet minstens 105 % en hoogstens 115 % van die aangeslane spanning van die stroombreker wees.

6.9.2 **Montering:** Monteer die stroombreker soos vir normale diens en verbind dit in die toetskring met geleiers elk met 'n lengte (aan die belastingkant sowel as aan die lynkant) van minstens 0,5–0,75 m elk en van die grootte in Tabel 2 aangegee teenoor die stroomaanslag van die stroombreker.

- 6.9.3 *Aarding van metaaldele*: Indien die stroombreker enige oop metaaldele bevat of indien dit bedoel is om op 'n metaalplaat of -steunstuk gemonteer te word, verbind al sodanige metaaldele (deur 'n sekering van vertinde koperdraad met 'n nominale diameter van 0,125 mm en 'n lengte van 75–100 mm) met die nulgeleierdraad in die geval van 'n ws-toevoer, of met 'n negatiewe pool in die geval van 'n gs-toevoer.
- 6.9.4 *Kaasdoek*: Bedek dié deel van die oppervlak van die stroombreker wat die werkhefboom bevat, met skoon, droë kaasdoek wat aan die vereistes vir graad 1-kaasdoek van SABS 446 'Verbandgaas (stof en deppers) en kaasdoek' voldoen. Maak seker dat geknipte of geskreunde rande van die kaasdoek nie regstreeks blootgestel is aan die boogopeninge waardeur vlamme uitgelaat kan word nie.
- 6.9.5 *Toetskring*:
- (a) *Eenpoolstroombreker*: Gebruik die kring soos in Fig. 4 of 5 gespesifiseer.
- (b) *Tweepool-, eenpool- en nulgeleier-, en eenpool- en skakelbeheerdenulgeleier-stroombrekers*: Gebruik die kring soos in Fig. 6 of 7 gespesifiseer.
- (c) *Driepool- of driepool- en nulgeleierstroombrekers*: Gebruik die kring soos in Fig. 8 gespesifiseer.
- (d) *Weerstand van spanningsmeetkring*: Die waarde van die weerstand van die spanningsmeetkring wat oor die aansluiters van 'n pool van 'n stroombreker verbind is, moet minstens 100Ω per volt van die kragfrekwensieherstelspanning wees.

6.9.6 *Prosedure*:

Vir al hierdie toetse moet die lewendige kant van die toetskring verbind word met die ooreenstemmende aansluiters van die stroombreker, soos deur die fabrikant gemerk. Indien sodanige merke ontbreek, moet die lewendige kant van die toetskring verbind word met die kant van die stroombreker wat die strafste toestand tot gevolg het. Indien daar twyfel bestaan oor watter die strafste toestand is, moet die stroombreker in albei toestand getoets word. Nuwe stroombrekers kan vir elk van die twee reekse toetse gebruik word of so nie is onderhoudswerk tussen die toetsreekse toelaatbaar.

(a) *In die geval van WS*:

(1) Met die toetskring ingestel op die toepaslike spanningswaarde, waarskynlike stroom en drywingsfaktor in Tabel 6 aangegee, onderwerp op stroombreker aan 'n breektoets deur gebruik te maak van punt-op-golfskakeling om die grootste moontlike oorgangstroom te verkry. Hou die herstelspanning minstens 0,1 sekonde lank vol nadat die boog uitgedoof is. Onderwerp die stroombreker na 'n tydsverloop van minstens twee minte en hoogstens 15 minute (die inherente terugkeertyd) aan 'n sluit-en-breektoets en hou die herstelspanning minstens 0,1 sekonde lank vol nadat die boog uitgedoof is. Teken van amplitudes sowel as die duur van die spanning en stroom tydens albei toetse aan dmv 'n ossillograaf of op ander aanneemlike wyse.

TABEL 6—WAARDES VAN WAARSKYNLIKE STROOM EN DRYWINGSFAKTOR VIR BREEK-VERMOËTOETS

1	2	3
Breekvermoëklas	Waarskynlike stroom, simmetriese WGK, A	Drywingsfaktor, naloop
SABS 1,5 kA	1 500 GS	—
SABS 2,5 kA	2 500 WS	0,45–0,5
SABS 5 kA	5 000 WS	0,45–0,5
SABS 7,5 kA	7 500 WS	0,45–0,5
SABS 10 kA	10 000 WS	0,45–0,5
SABS 12,5 kA	12 500 WS	0,25–0,3
SABS 15 kA	15 000 WS	0,25–0,3
SABS 20 kA	10 000 WS	0,25–0,3
SABS 25 kA	12 000 WS	0,15–0,2
SABS 30 kA	30 000 WS	0,15–0,2
SABS 35 kA	35 000 WS	0,15–0,2
SABS 45 kA	45 000 WS	0,15–0,2
SABS 55 kA	55 000 WS	0,15–0,2
SABS 75 kA	75 000 WS	0,15–0,2
SABS 100 kA	100 000 WS	0,15–0,2

(2) Gaan die stroombreker na afloop van die breek- en die sluit-en-breektoets na vir voldoening aan die vereistes aan 4.9.2 (a), (b), (d) en (e).

(3) Bepaal die kragfrekwensieherstelspanning volgens 6.9.7 hieronder aan die hand van die ossillogramme en gaan na vir voldoening aan die vereistes van 4.9.2 (c).

(4) Toets die oorstroomuitklinker (indien daar een is) van die stroombreker volgens 6.6.2 by 135 % of 200 % van die aangeslane stroom, soos toepaslik, en gaan na vir voldoening aan die vereistes van 4.9.2 (f).

(5) Lê ten slotte 'n wisselspanning, van die toepaslike waarde in Tabel 7 en naastenby sinusgolvormig, aan tussen die dele in onderafdeling 6.3 aangegee.

Begin die toets teen 'n spanning van hoogstens een derde van die gespesifiseerde toetsspanning en verhoog die spanning so vinnig as wat die meetinstrument die werklike waarde daarvan kan registreer, tot die volle toetswaarde. Hou die volle toetsspanning een minuut lank vol en verminder dit dan vinnig tot hoogstens een derde van hierdie waarde voordat dit afgeskakel word. Gaan na vir voldoening aan die vereistes van 4.9.2 (g).

(b) *In die geval van GS:*

(1) Met die toetskring ingestel op die toepaslike spanningswaarde en 'n waarskynlike stroom van 1 500 A, onderwerp die stroombreker aan 'n breektoets en hou die herstelspanning minstens 0,1 sekonde lank vol nadat die boog uitgedoof is. Onderwerp die stroombreker na 'n tydsverloop van minstens twee minute en hoogstens 15 minute (die inherente terugkeertyd) aan 'n sluit-en-breektoets en hou die herstelspanning minstens 0,1 sekonde lank vol nadat die boog uitgedoof is. Teken die amplitudes sowel as die duur van die spanning en stroom tydens albei toetse aan dmv 'n ossillograaf of op ander aanneemlike wyse.

Gaan voort soos in geval van WS, deur stap (2), (3), (4) en (5) in (a) hierbo te volg.

TABEL 7—TOETSSPANNING

1	2
Aangeslane spanning, V	Toetsspanning, V (WKG)
Hoogstens 250.....	1 500
Bo 250 maar hoogstens 500.....	2 000
Bo 500 maar hoogstens 660.....	2 000
Bo 660 maar hoogstens 1 000.....	3 000

6.9.7 *Vertolking van ossillogramme:*

(a) *Bepaling van aangelegde spanning en kragfrekwensieherstelspanning:* Bepaal die aangelegde spanning en die kragfrekwensieherstelspanning aan die hand van die ossillogramme wat tydens die kalibrering van die kring, die breektoets en die sluit-en-breektoets verkry is, deur 'n raming van hierdie spannings te doen volgens die voorbeelde wat in Fig. 1 vir WS-spanning en Fig. 2 vir GS-spanning aangetoon word. (Fig. 1 en 2 het op die sluit-en-breektoets betrekking.)

Meet die kragfrekwensieherstelspanning gedurende die eerste halvesiklus (sonder oorgangsverskynsels) nadat die boog uitgedoof is, asook gedurende die volgende vyf opeenvolgende spitse. Neem die som van hierdie ses spitse gedeel deur $6\sqrt{2}$ as die WKG-kragfrekwensieherstelspanning vir elke fase soos in Fig. 1 (b) en (c) aangetoon en gaan na vir voldoening aan die vereistes van 4.9.2 (c).

Opm: Die aandag word daarop gevestig dat, vanweë die invloed van—

- (1) korttermynvariasies in die isolasieweerstand van 'n stroombreker,
- (2) korttermynvariasies in die isolasieweerstand van booggapings, of
- (3) die weerstand in herstelspanningsmeetkringe, of enige kombinasie hiervan, daar by sekere tipes driepoolstroombrekers 'n neiging bestaan vir die kragfrekwensieherstelspanning oor elke pool van die stroombreker om korttermynvariasies in amplitude te ondergaan, wat laer daal as 105 % en hoër styg as 115 % van die aangeslane spanning van die stroombreker. By ander tipes driepoolstroombrekers is onreëlmatige korttermynvariasies in die kragfrekwensieherstelspanning waargeneem, waartydens die amplitude van ongeveer nulwaarde tot volle herstelspanning oor een pool kan wissel, terwyl die herstelspanning oor die ander twee pole korttermynvariasies in amplitude toon wat kan wissel van 'n waarde bo tot 'n waarde onder die gespesifiseerde grense. Indien daar twyfel bestaan oor voldoening van die stroombreker aan die vereistes vir kragfrekwensieherstelspanning, neem drie bykomende stroombrekers en onderwerp hulle aan die breek- en sluit-en-breektoets volgens die prosedure in 6.9.6 hierbo, maar met die nulgeleier van die toevoerbron met die gemeenskaplike aardverbinding (punt F in Fig. 8) verbind.

(b) *Bepaling van die waarskynlike breekstroom*: In die geval van WS, bepaal die waarde van die waarskynlike breekstroom deur die stroomspoor wat tydens die kalibrering van die kring verkry is [kyk Fig. 1 (a)], te vergelyk met dié wat tydens die breektoets (die ossillogram hiervan word nie in Fig. 1 aangetoon nie) of tydens die sluit-en-breektoets [kyk Fig. 1 (b)] verkry is. Neem die waarskynlike breekstroom in elke fase as die waarde van die WGK-kragfrekwensiekomponent van die kalibreerstroombreek wat met die oomblik van skeiding van die boogkontakte ooreenstem [waardes wat met A_1 of A_2 in Fig. 1 (a) ooreenstem]. Maak seker dat die waarskynlike stroom in enige fase nie met meer as 10 % van die gemiddelde waarde verskil nie. In die geval van GS, neem die waarde van die waarskynlike breekstroom as gelyk aan die maksimum waarde A_2 , soos bepaal aan die hand van die kalibreerkromme, in die geval van stroombrekers wat die stroom breek voordat dit die maksimum waarde bereik, en gelyk aan die waarde A in die geval van stroombrekers wat die stroom breek nadat dit die maksimum waarde bereik het (soos in Fig. 2 aangetoon), hetsy tydens die sluit-en-breektoets of tydens die breektoets (nie in Fig. 2 aangetoon nie).

(c) *Bepaling van die waarskynlike spitsluitstroom*: Bepaal die spitsluitstroom aan die hand van die kalibreer- ossillogram en neem die waarde daarvan as gelyk aan A_3 in die geval van WS [kyk Fig. 1 (a)], en gelyk aan A_2 in die geval van GS [kyk Fig. 2 (a)]. In die geval van 'n driefasetoets, neem die hoogste van die A_3 -waardes wat dmv die ossillogram verkry is.

Opm.: Die aandag word daarop gevestig dat, in die geval van toetse op eenpoolstroombrekers, die waarskynlike spitsluitstroom wat aan die hand van die kalibreerossillogram bepaal is, kan verskil van die waarde van die waarskynlike spitsluitstroom wat in die toets verkry is, na gelang van die oomblik waarop die stroom gesluit word.

6.10 TOETS VIR MEGANIESE STERKTE.

6.10.1 Apparaat:

(a) 'n *Meganiesesterktoets-apparaat* soos in Fig. 3 aangetoon. Die metaalsilinder A het 'n massa van 250 g en 'n buitenediameter van 25 mm en pas los oor die leistung B. Die leistung is nie vas aan die raam van die toetsapparaat nie en kan maklik op- en afgeskuif word. 'n Hardeveselwaster C met 'n diameter van 25 mm en 'n dikte van 12,5 mm is aan die onderent van die leistung bevestig.

(b) 'n *Reghoekige loofhoutblok D* wat op die basis van die toetsapparaat pas.

6.10.2 Eksemplaar: Gebruik een stroombreker uit die monster.

6.10.3 Prosedure:

(a) Plaas die loofhoutblok op die basis van die toetsapparaat en hou die eksemplaar styf op die blok vas of monteer dit op 'n ander wyse daarop sodat die monteervlak daarvan na onderwys (d.w.s. met die werkhefboom bo).

(b) Lig die leistung en beweeg die blok so dat, wanneer die leistung laat sak word, die veselwaster op die oppervlak van die eksemplaar rus. Laat die leistung sak, lig die metaalsilinder tot 'n hoogte van 250 mm bo die veselwaster en laat die silinder op die veselwaster val.

(c) Herhaal die valprosedure twee maal en maak seker dat die werkhefboom aan een val onderwerp word terwyl dit in die AF-posisie is.

(d) Draai die eksemplaar so dat dit op sy sykant op die blok lê. Volg die prosedure in (b) hierbo beskryf en onderwerp die eksemplaar aan drie valle, twee na willekeur (maar nie op 'n rand van die eksemplaar nie) en een ongeveer in die middel van die aansluiterskut.

(e) Draai die eksemplaar op die ander sy en herhaal die prosedure in (d) hierbo.

(f) Ondersoek die eksemplaar nadat dit aan die nege valle onderwerp is, vir voldoening aan die vereiste van 4.8.

6.11 TOETS VIR LEESBAARHEID VAN ETIKETTE EN KLEWING VAN KLEEFETIKETTE.

6.11.1 *Voorbereiding van eksemplare*: Kondisioneer drie stroombrekers 168 ± 2 uur lank in 'n geventileerde oond by 70 ± 2 °C. In die geval van 'n kleefetiket, trek die etiket binne drie minute nadat elke stroombreker uit die oond gehaal is, oor ongeveer 'n kwart van die lengte daarvan af (sonder om die res van die etiket uit die oorspronklike posisie te verwyder). Laat die stroombreker (minstens vier uur lank) tot kamertemperatuur afkoel voordat die toets hieronder beskryf, uitgevoer word.

6.11.2 Prosedure:

(a) *Alle etikette*: Week 'n stuk kaasdoek wat voldoen aan die vereistes vir graad 1-kaasdoek van SABS 446 'Verbandgaas (stof en deppers) en kaasdoek' in kraanwater en vryf die kaasdoek altesaam 30 maal in elke rigting (vorentoe en agtertoe) oor die merke op die etiket terwyl 'n druk van 0,05–0,1 MPa aangewend word. Herhaal die toets met kaasdoek wat in petroleumeter geweek is en ondersoek dan die merke en gaan na vir voldoening aan 5.3.

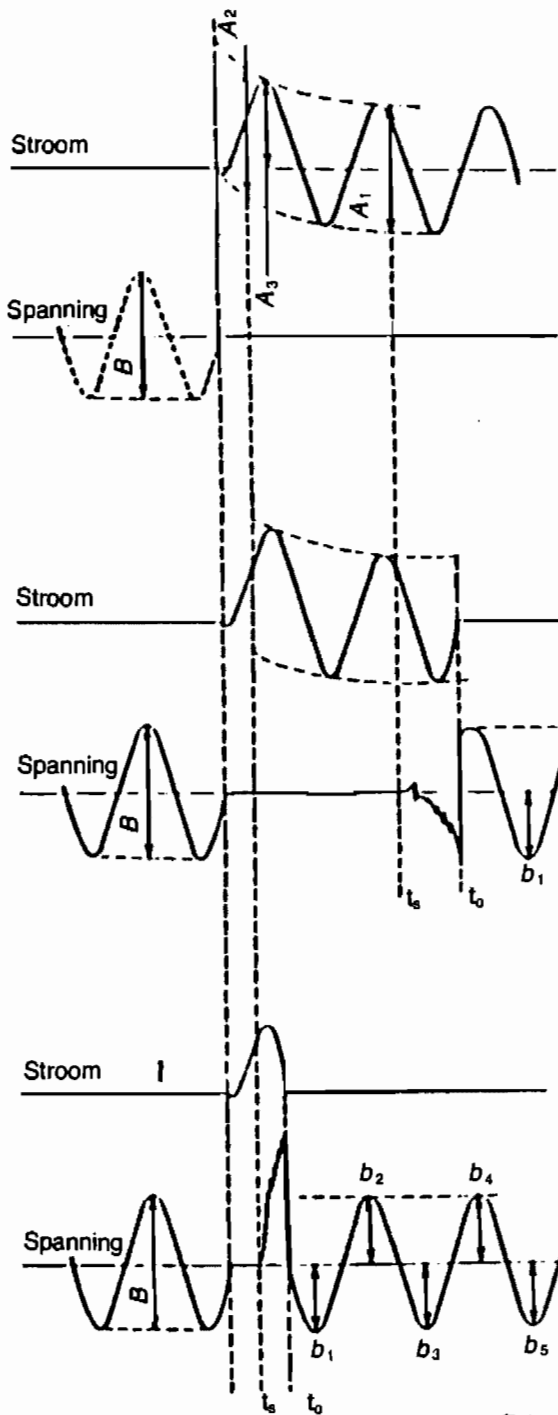

- (a) Kalibrering van die stroombaan.
 Waarskynlike spitsluitstroom = A_3
 Waarskynlike simmetriese verbreekstroom
 $= \frac{A_2}{2\sqrt{2}}$ of $\frac{A_1}{2\sqrt{2}}$
 Aangelegde spanning = B
- (b) Ossillogram verkry in 'n sluit-en-verbreekttoets nadat die stroom spitswaarde bereik het.

Kortsluitvermoë:
 Stroom $I_{spits} = A_3$ teen spanning U_{wgk}
 $= \frac{B}{2\sqrt{2}}$

Kortsluitingverbreekvermoë:

Stroom $I_{wgk} = \frac{A_1}{2\sqrt{2}}$

teen spanning

$U_{wgk} = \frac{(b_1 + b_2 + b_3 + b_4 + b_5 + b_6)}{6\sqrt{2}}$

- (c) Ossillogram verkry in 'n sluit-en-verbreekttoets voordat die stroom spitswaarde bereik.

Kortsluitvermoë:
 Stroom $I_{spits} = A_3$ teen spanning U_{wgk}
 $= \frac{B}{2\sqrt{2}}$

Kortsluitingverbreekvermoë:

Stroom $I_{wgk} = \frac{A_2}{2\sqrt{2}}$

teen spanning

$U_{wgk} = \frac{(b_1 + b_2 + b_3 + b_4 + b_5 + b_6)}{6\sqrt{2}}$

Tek11633/A

t_s = Skelding van kontakte
 t_o = Uitdwinging van boog

FIG. 1—Verflering van Sluit- en Breekvermoë in Kortsluittoestande met WS

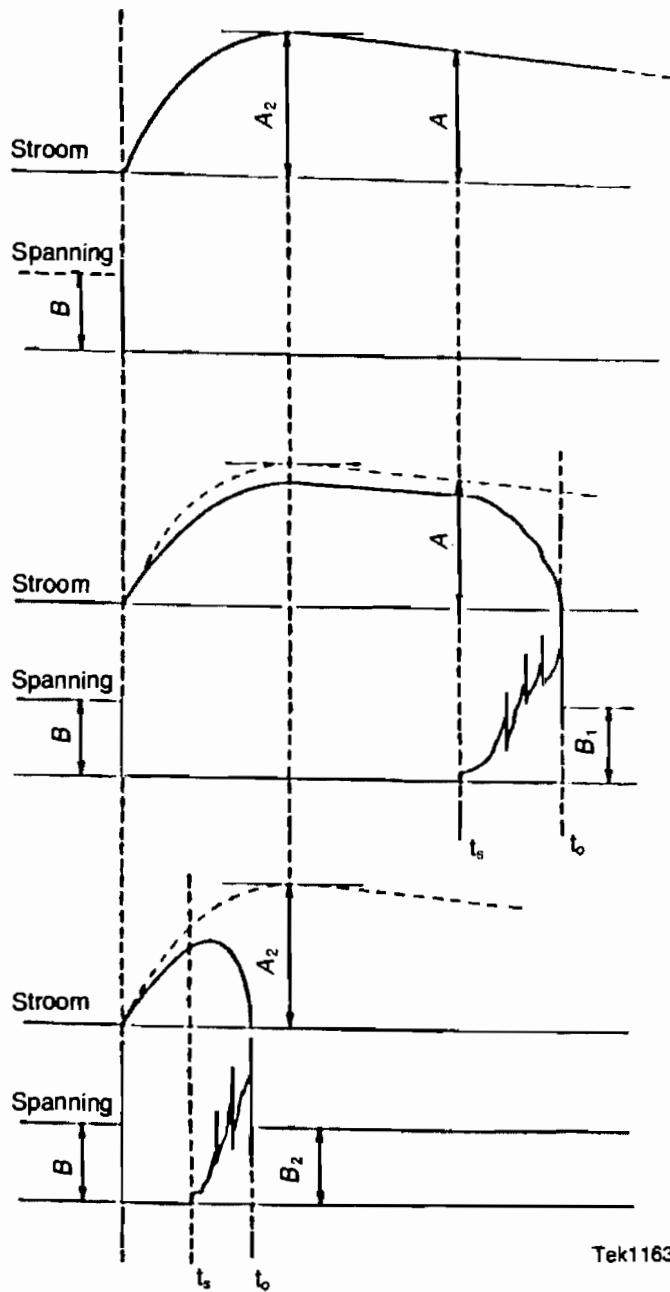

- (a) Kalibrering van die stroombaan.
 Waarskynlike spitsluitstroom = A_2
 Aangelegde spanning = B
- (b) Ossilogram verkry in 'n sluit-en-verbreektoets nadat die stroom maksimum waarde bereik het.
 Kortsluitingverbreekvermoë:
 Stroom $I = A$ teen spanning $U = B_1$
 Kortsluitvermoë:
 Stroom $I = A_2$ teen spanning $U = B$
- (c) Ossilogram verkry in 'n sluit-en-verbreektoets voordat die stroom maksimum waarde bereik.
 Kortsluitingverbreekvermoë:
 Stroom $I = A_2$ teen spanning $U = B_2$
 Kortsluitvermoë:
 Stroom $I = A_2$ teen spanning $U = B$

Tek11634/A

FIG. 2—Verifiëring van Sluit- en Breekvermoë In kortsluittoestande met GS

(b) *Kleefetikette*: Gebruik 'n trekskaal en 'n geskikte klamp wat aan die vry ent van die etikel (kyk 6.11.1) bevestig is om die etiket van die stroombreker te probeer verwyder deur 'n trekkrag van 0,15–0,18 N/mm van die etiketbreedte in vyf sekondes lank in 'n rigting loodreg op die etiketoppervlak aan te wend. Gaan na vir voldoening aan 5.3.

6.12 BRANDBAARHEIDSTOETS.

- 6.12.1 *Toetseksemplare*: Berei minstens 3 toetseksemplare met 'n breedte van ongeveer 12 mm, 'n lengte van ongeveer 50 mm en 'n dikte van ongeveer 12 mm voor uit die toepaslike dele van die stroombreker. (Sny die eksemplare tot 'n dikte van 12 mm indien die dikte van die materiaal 12 mm oorskry.)
- 6.12.2 *Kondisionering*: Kondisioneer die eksemplare minstens 18 uur lank in 'n atmosfeer met 'n relatiewe humiditeit van $75 \pm 5\%$ en 'n temperatuur van $20 \pm 2^\circ\text{C}$. Toets elke eksemplaar binne drie minute nadat dit uit die beheerde atmosfeer verwyder is.
- 6.12.3 *Apparaat*: 'n Toetsoond met 'n verhittingskamer soos in Fig. 9 aangetoon. Die oppervlakte van die opening bo in die koniese deksel is ongeveer 700 mm^2 en die totale oppervlakte van die lugtoevoeropening aan die onderkant van die oond is ongeveer 70 mm^2 . 'n Ligte draadstiebeuel kan gebruik word om die eksemplaar te steun en die steun moet so opgestel word dat die eksemplaar in die middel van die verhittingskamer gehou word, met die langste afmeting vertikaal en die boonste ent ongeveer 70 mm onder die voorbrandvlam. Die apparaat word verhit deur 'n elektriese stroom wat op geskikte wyse gereguleer word, deur 'n verhittingselement rondom die verhittingskamer te stuur.
- 6.12.4 *Temperatuurmeting*: Beskou die temperatuur wat geregistreer word deur 'n termokoppel wat op die hoogte van die middel van die eksemplaar en ewe ver van die binneoppervlak van die kamer en die eksemplaar geplaas is, as die temperatuur van die verhittingskamer.
- 6.12.5 *Prosedure*: Laat die eksemplaar in die verhittingskamer hang, verhoog die temperatuur van die verhittingskamer tot $300 \pm 5^\circ\text{C}$ terwyl die eksemplaar en voorbrandvlam dopgehou word en hou hierdie temperatuur vyf minute lank vol. Teken enige eksemplaar wat brand of wat vlambare dampe afgee wat by die voorbrandvlam aan die brand slaan, as defektief aan.

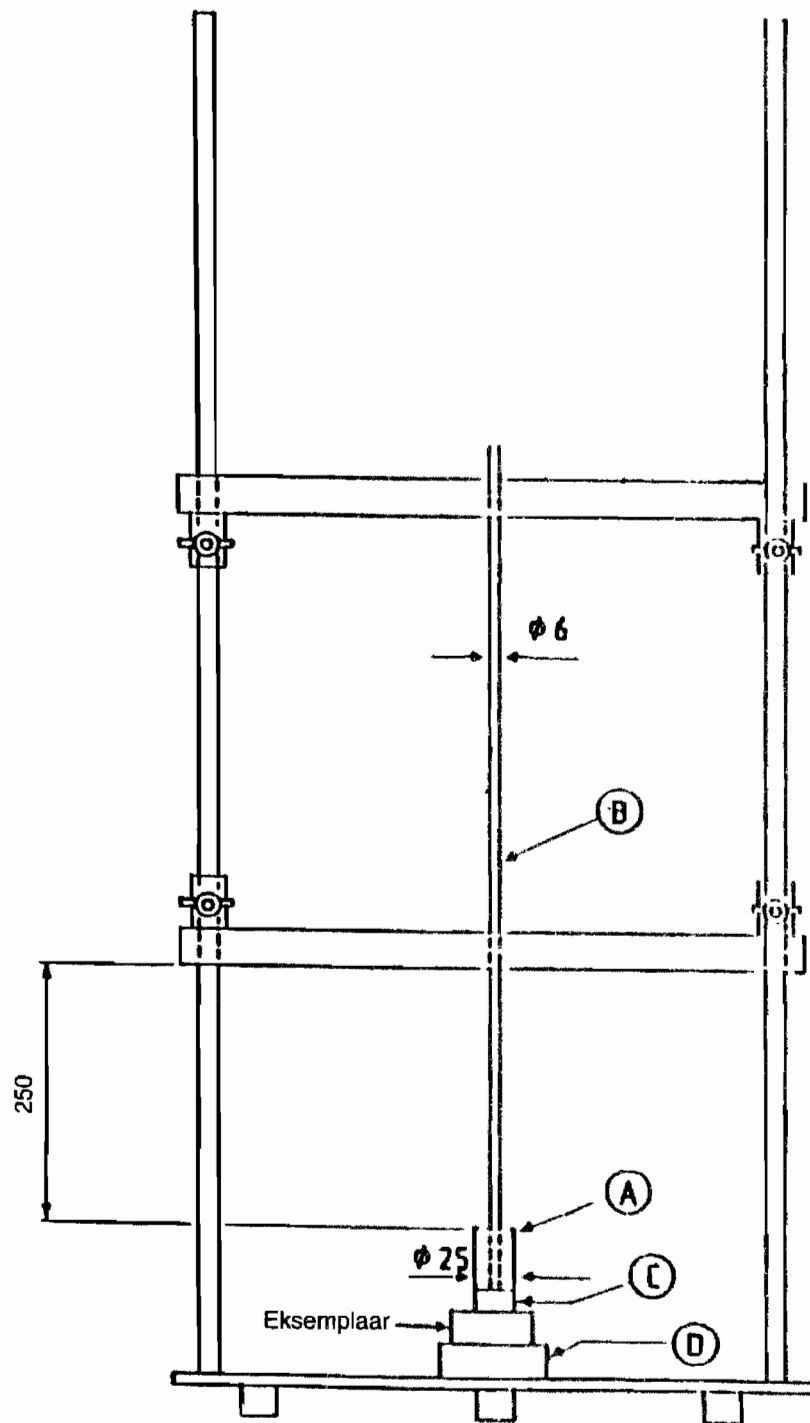

Afmetings in millimeter

Tek11632/A

FIG.3—Apparaat vir die Toets vir Meganiese Sterkte

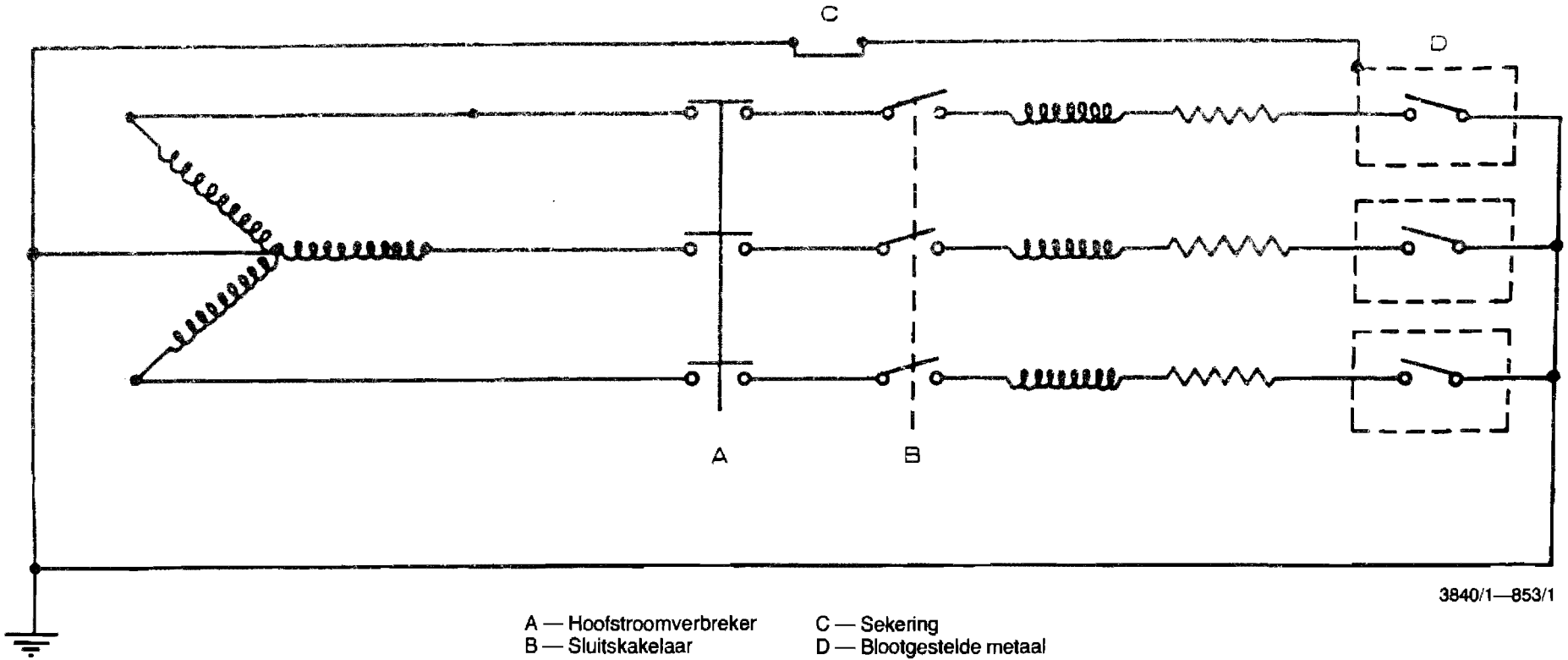

3840/1—853/1

FIG. 4—Stroombaandiagram vir Verbreekvermoëtoets op Eenpoolstroomverbrekers

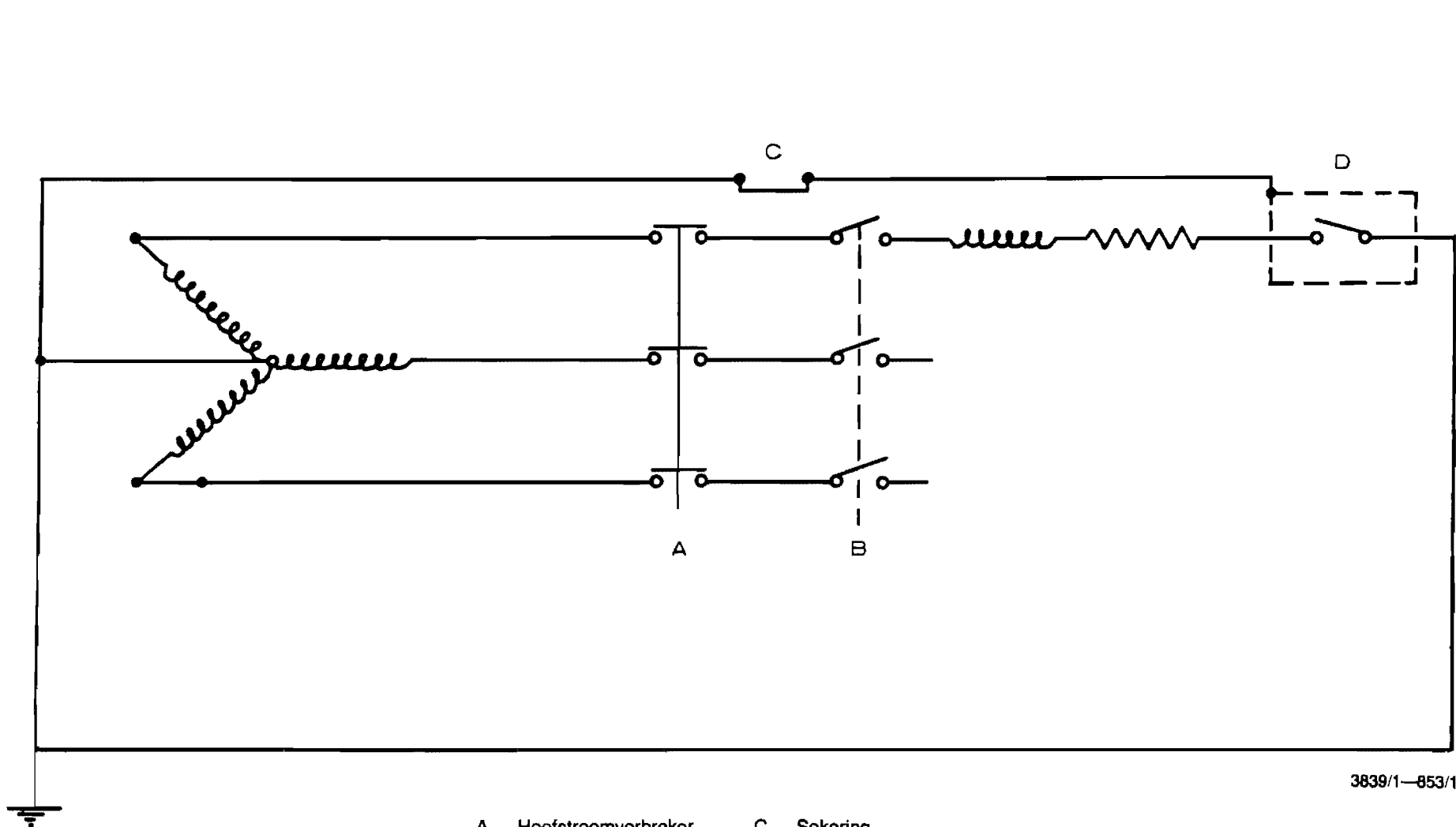

3839/1—853/1

- A — Hoofstroomverbreker
- B — Sluitskakelaar
- C — Sekering
- D — Blootgestelde metaal

FIG. 5—Stroombaandiagram vir Alternatiewe Verbreekvermoëtoets op Eenpoolstroomverbrekers

3852/1—853/1

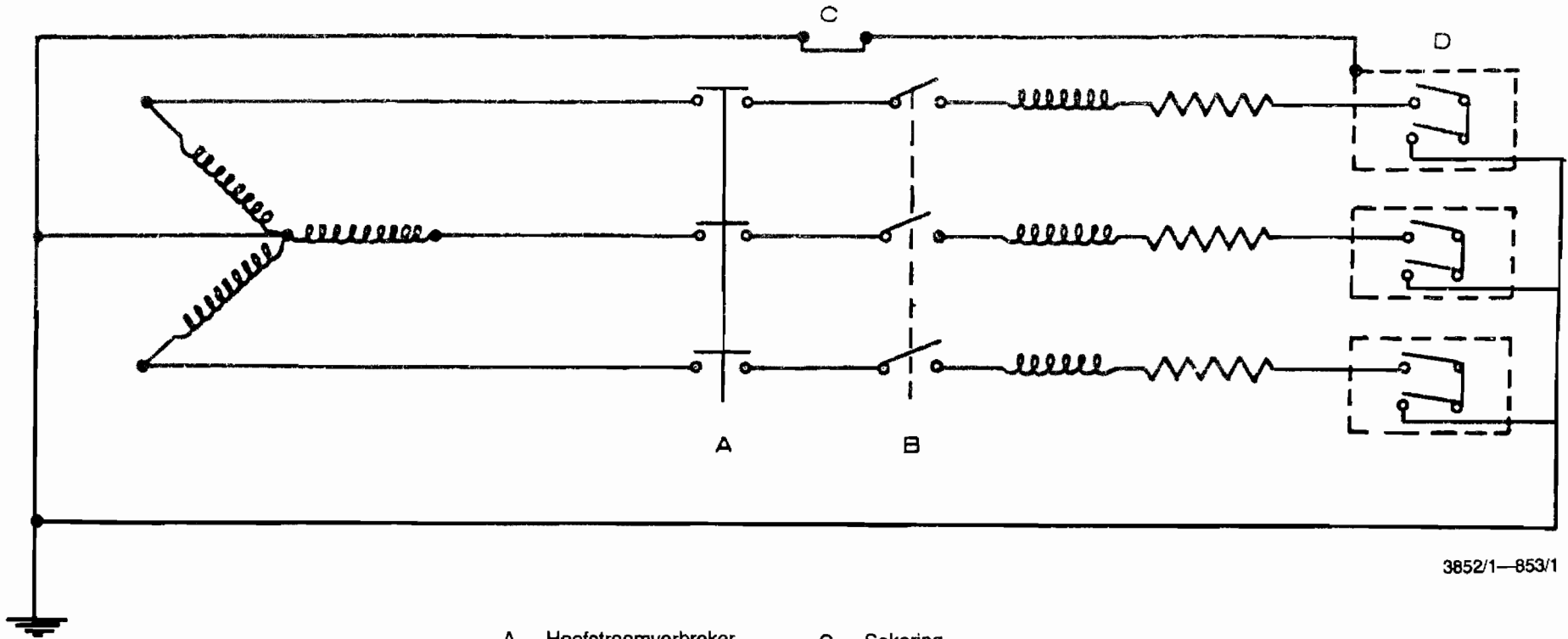

- A — Hoofstroomverbreker
- B — Sluitskakelaar
- C — Sekering
- D — Blootgestelde metaal

FIG. 6—Stroombaandiagram vir Verbreekvermoëtoets op Tweepoolstroomverbrekers

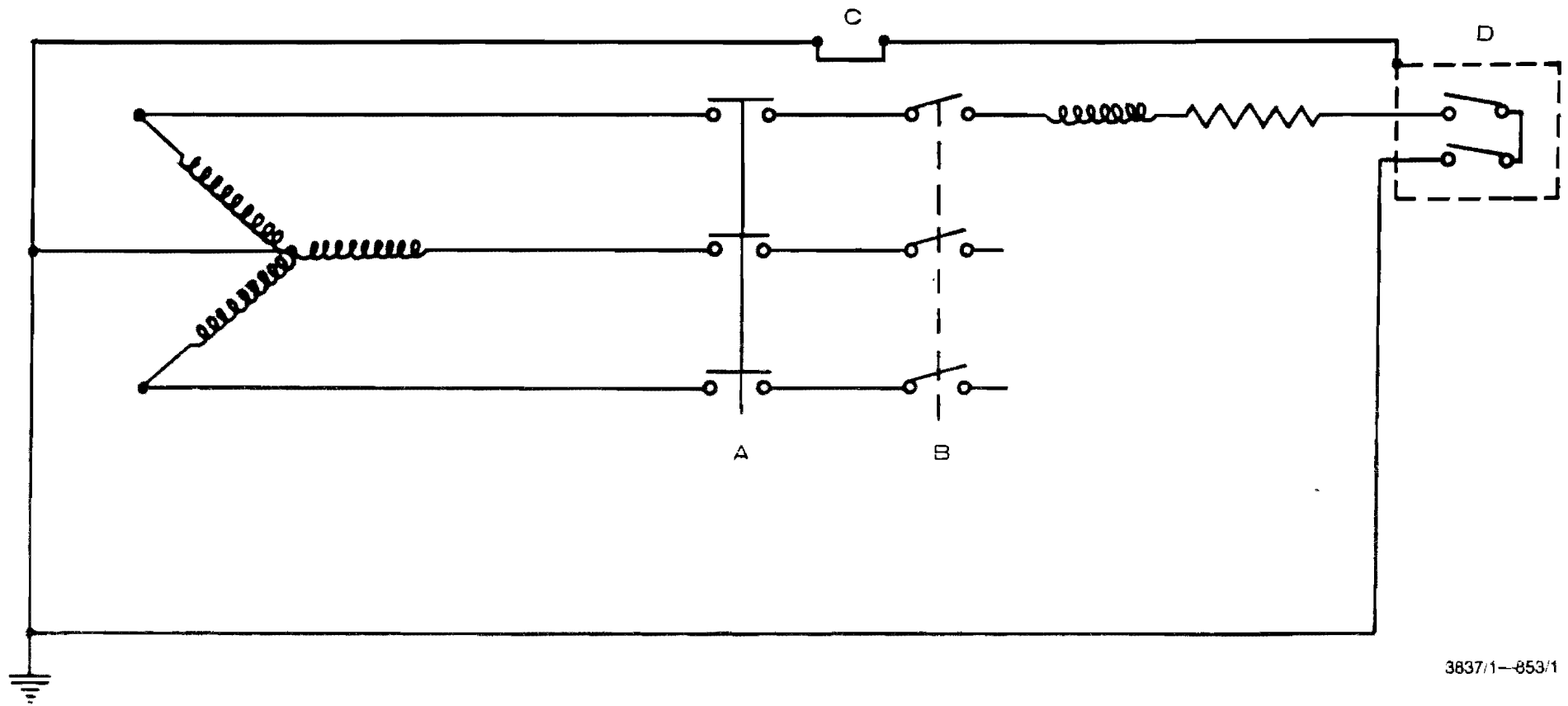

A — Hoofstroomverbreker C — Sekering
B — Stuitskakelaar D — Blootgestelde metaal

FIG. 7—Stroombaandiagram vir Alternatiewe Verbreekvermoëtoets op Tweepoolstroomverbrekers

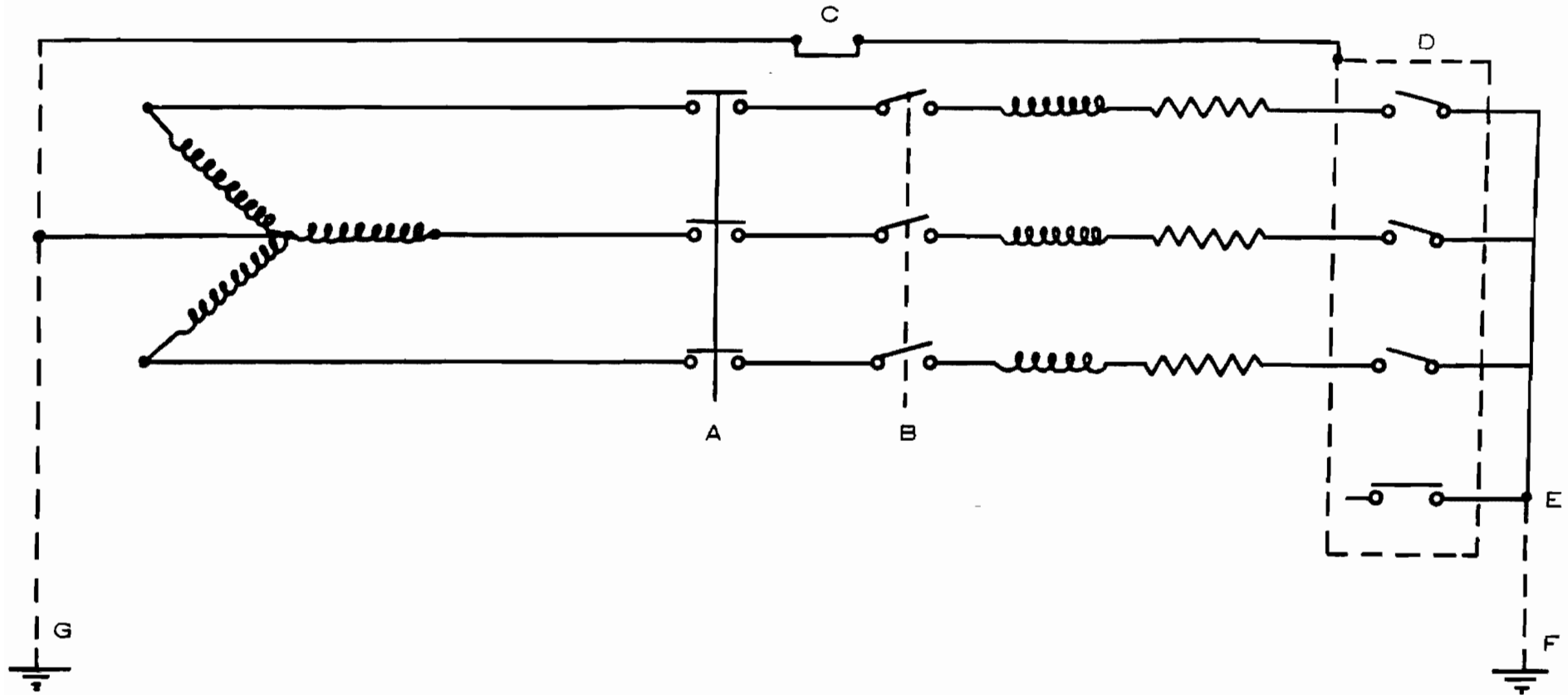

- | | |
|--------------------------|-------------------------------------|
| A — Hoofdstroomverbreker | D — Blootgestelde metaal |
| B — Sluitskakelaar | E — Neutrale skakel |
| C — Sekering | F, G — Alternatiewe aardverbindings |

3838/1—853/1

FIG. 8—Stroombaandiagram vir Verbreekvermoëtoets op Driepoolstroomverbrekers

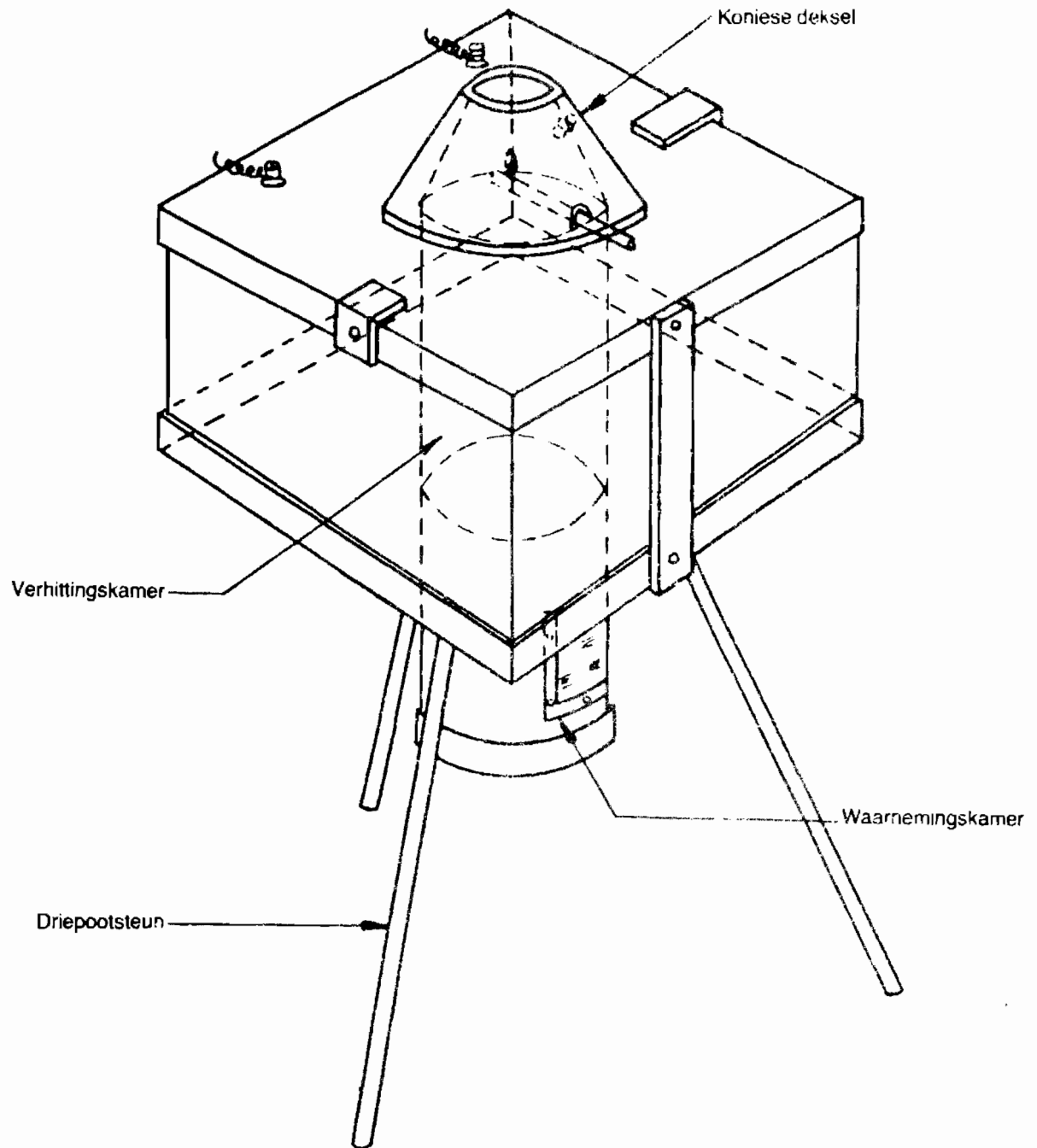

1668 1—37.1

FIG. 9 (a)—Skets van Opgestelde Apparaat

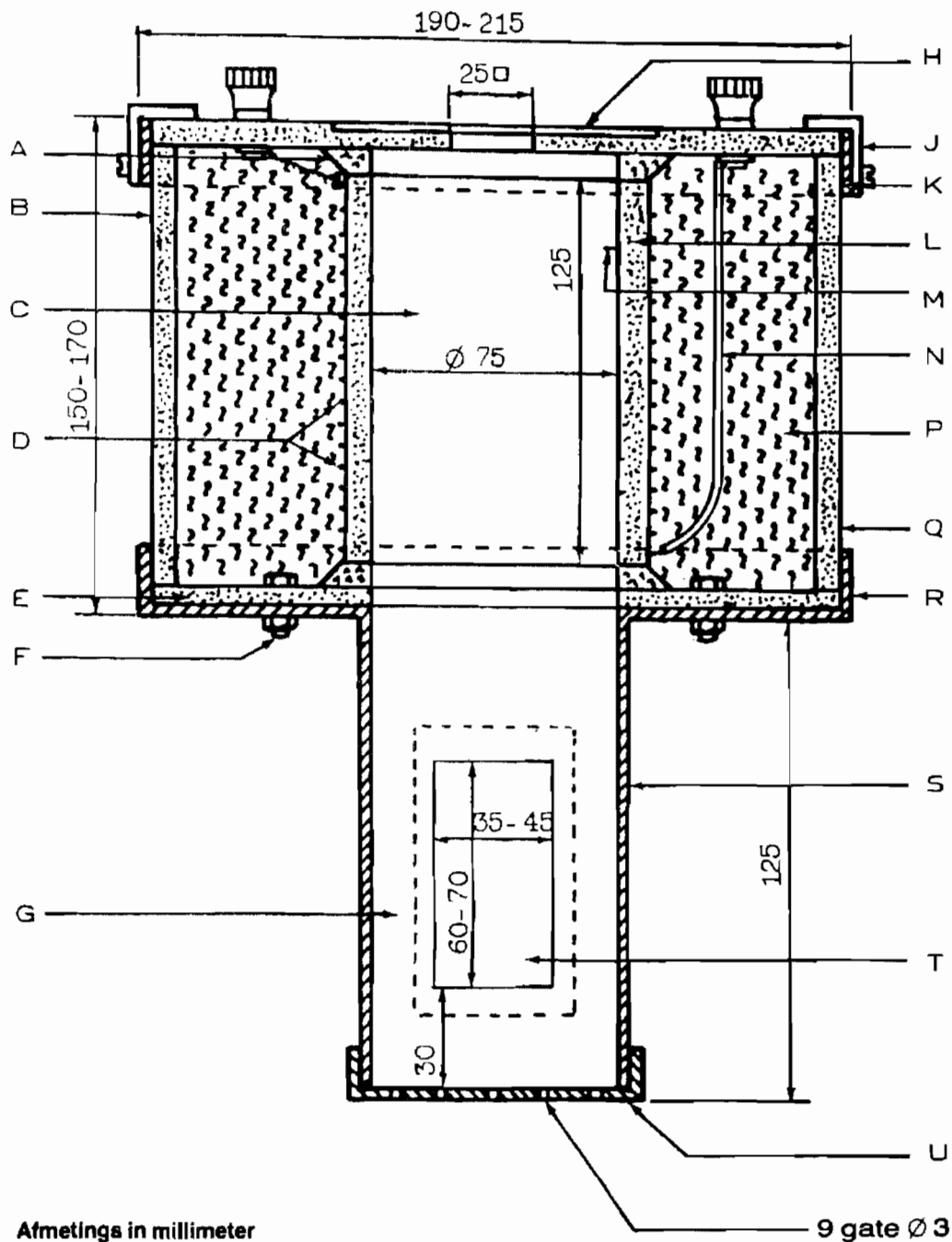

Afmetings in millimeter

9 gate $\text{Ø } 3$

1669/1—37/2

- A—Vuurvaste sement
- B—Asbessementplaat
- C—Verhittingskamer
- D—Nichroomelement
- E—Asbesbord
- F—Geelkoperbout
- G—Waarnemingskamer
- H—Inlating vir plasing van koniese deksei
- J—Metaalknip

- K—Metaalband
- L—Buis van vuurvaste klei of silika
- M—Termokoppel
- N—Hittebestande isolasie
- P—Pakking van asbeswol of magnesia-asbes
- Q—Asbessementplaat
- R—Hoekyster
- S—Metaalsiinder
- T—Mikavenster
- U—Skrœf- of glydop

FIG. 9 (b)—Besonderhede van Oond

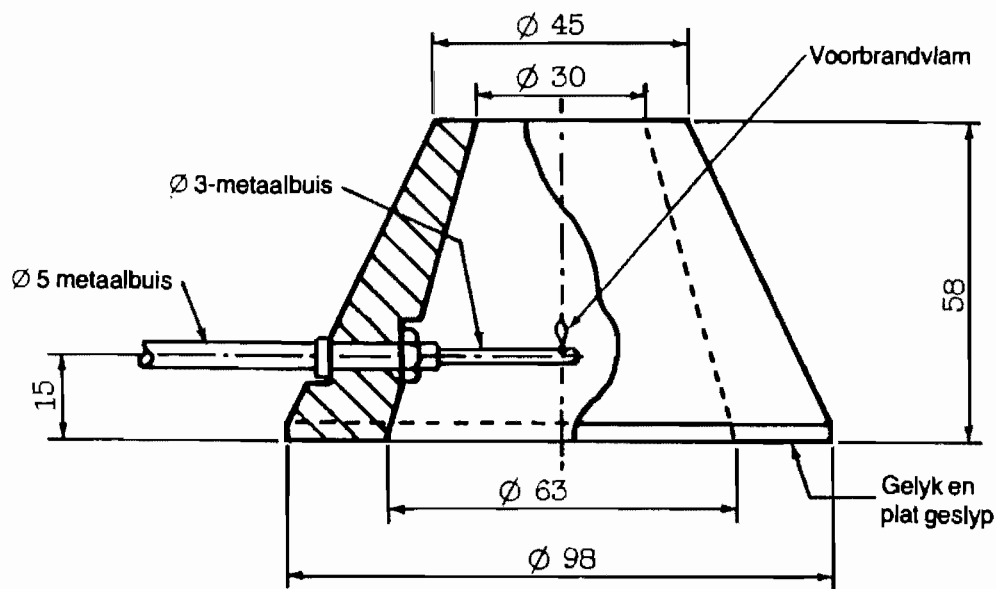
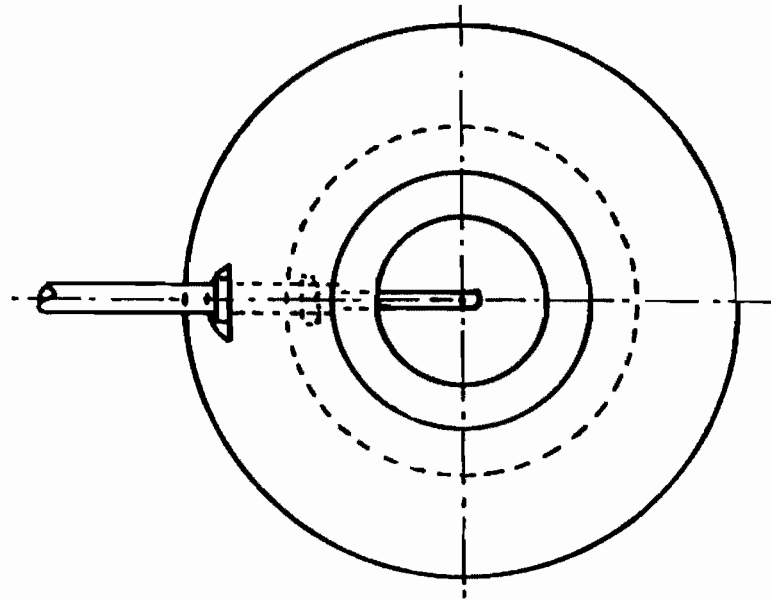

Afmetings in millimeter

1670/2—37/2

FIG. 9 (c)—Besonderhede van Koniese Deksel

SCHEDULE**COMPULSORY SPECIFICATION FOR MOULDED-CASE CIRCUIT-BREAKERS****1. SCOPE.**

- 1.1 This specification covers single-pole and multipole air-break circuit-breakers, assembled as an integral unit in a supporting and enclosing moulded case of insulating materials, for current ratings not exceeding 1 000 A, alternating voltages not exceeding 1 000 V and direct voltages not exceeding 500 V.
- 1.2 This specification does not cover contactors or motor starters and controllers.

Note:

(a) The specification covers safety requirements for circuitbreakers used under normal conditions. Where the conditions are abnormal (e.g. during the presence of corrosive or explosive fumes, dust, excessively high or low temperatures, excessive vibration, high humidity, and other unusual operating conditions), advice on installation and use should be sought from the manufacturer or the supplier.

(b) The circuit-breakers covered by this specification are intended for use in conjunction with copper conductors. Conductors of other material may be used provided suitable terminations are available.

2. DEFINITIONS.

- 2.1 For the purposes of this specification the following definitions shall apply:

Acceptable: Acceptable to the authority administering this specification.

a-contact: A control contact or auxiliary contact that is closed when the main contacts of the mechanical switching device are closed and open when they are open.

b-contact: A control contact or auxiliary contact that is open when the main contacts of the mechanical switching device are closed and closed when they are open.

Breaking capacity: The highest prospective current that, according to the manufacturer, the circuit-breaker will break and make-and-break successfully at the specified voltage under prescribed conditions of use and behaviour.

Circuit-breaker (breaker): A mechanical switching device, capable of making, carrying and breaking currents under normal circuit conditions and also making, carrying for a specified time, and breaking currents under specified abnormal circuit conditions such as those of short-circuit or earth fault.

Note: A circuit-breaker is usually intended to operate infrequently although some types are suitable for frequent operation.

Double-pole circuit-breaker: A circuit-breaker having two poles for connection in the two conductors of a supply, each pole being fitted with one or more different releases, the poles being so coupled (mechanically) with each other that they operate together and if a fault on *any one* pole occurs, the supply will be isolated.

Single-pole and neutral circuit-breaker: A circuit-breaker having two poles that are coupled mechanically in such a manner as to operate together, and only one of which is fitted with one or more different releases.

Single-pole and switched-neutral circuit-breaker: A single-pole circuit-breaker fitted with a switched neutral that is arranged to operate with the pole of the circuit-breaker, and to close before and open after the pole contacts, for the purpose of isolating the neutral conductor.

Single-pole circuit-breaker: A circuit-breaker having one pole, the pole being fitted with one or more different releases.

Triple-pole and neutral circuit-breaker: A circuit-breaker having four poles, three of which are fitted with one or more different releases, all the poles being so coupled (mechanically) that they operate together, a fault on one or more phases resulting in isolation of the supply.

Note: The three poles fitted with releases are intended for connection in the phase conductors, and the fourth pole in the neutral conductor, of a three-phase four-wire supply.

Triple-pole and switched-neutral circuit-breaker: A triple-pole circuit-breaker fitted with a switched neutral that is arranged to operate with the main poles of the circuit-breaker, and to close before and open after the pole contacts, for the purpose of isolating the neutral conductor in a three-phase four-wire supply.

Triple-pole circuit-breaker: A circuit-breaker having three poles each being fitted with one or more different releases, and so coupled (mechanically) that they operate together.

Note: This arrangement is intended for use on a three-phase supply where control of the three phases is required to be simultaneous and where a fault on one or more phases will result in isolation of the supply.

Clearance: The shortest distance measured through air between two conductive parts.

Creepage distance: The shortest path between two conductive parts measured along the surface of an insulating material.

Note: A joint between two pieces of insulating material is considered part of the surface.

Current: When applied to an alternating current circuit, the root-mean-square value of the current.

Frame size: A term applied to a group of circuit-breakers of the same type, having the same breaking capacity, and physically interchangeable with each other, the size being denoted by the type number and the highest current rating that is assigned to breakers within the group.

Inherent resetting time: The time interval between a breaking operation during specified abnormal conditions and the successful reclosing of the breaker under normal conditions.

Pole: A conducting path in a circuit-breaker equipped with a set of contacts for carrying making and breaking the main current through the circuit-breaker.

Power-frequency recovery voltage: The recovery voltage after transient voltage phenomena have subsided.

Note: This definition applies also in the case of direct current, the frequency then being considered as zero.

Prospective current: The current (the direct current or the r.m.s. value of the alternating component of an alternating current) that would flow on the making of a circuit where the circuit is equipped for the insertion of a circuit-breaker where a link of negligible impedance is inserted instead of the circuit-breaker. (In some circuits the link may replace the EL circuit-breaker and the connecting leads from the supply.)

Rated load current: The highest load current, assigned by the manufacturer, that the circuit-breaker is capable of carrying continuously at the rated voltage under specified conditions, without exceeding the temperature limits specified.

Note: Unless otherwise stated, the value of an a.c. current shall mean an r.m.s. value and the value of a d.c. current shall mean an average value with a current ripple not exceeding 4 %.

Rated value: The numerical value of a quantity (such as voltage, current) included in the rating and indicated in the marking.

Rated voltage: The highest voltage, assigned by the manufacturer, at which the circuit-breaker may be used.

Note: Unless otherwise stated, the value of an a.c. voltage shall mean an r.m.s. value and the value of a d.c. voltage shall mean an average value with a voltage ripple not exceeding 4 %.

Recovery voltage: The voltage that appears across the terminals of a pole of a circuit-breaker after breaking of the current.

Note: This voltage may be considered in two successive intervals of time, one during which a transient voltage exists, followed by a second one during which power-frequency voltage alone exists.

Release:

Non-time-delay (overcurrent) release: A tripping device without any purposely delayed action.

Overcurrent release: A release that permits a circuit-breaker to open with or without delay when the current in the release exceeds a predetermined value.

Shunt release: A trip coil energized from the main circuit or from a separate auxiliary supply through a relay, a switch or other means.

Time-delay (overcurrent) release: A trip device with a purposely delayed action.

Undervoltage release: A release that permits a circuit-breaker to open with or without delay, when the voltage across the terminals of the release falls below a predetermined value and that permits the circuit-breaker to be closed when the voltage across the terminals is above a predetermined value.

Solid neutral: In a circuit-breaker, a conducting path which is not equipped with a set of contacts and to which the neutral paths, both incoming and outgoing, are connected one at each end.

Switched neutral: A pair or contacts in a conducting path normally at or about earth potential, capable of carrying the rated current of the circuit-breaker, and also capable of carrying, for a specified time, currents under specified abnormal circuit conditions (such as those of short-circuit), but not designed to make or break currents through the circuit.

Transient recovery voltage (abbreviation: TRV): The recovery voltage during the time in which it has a significant transient character.

Note:

(a) The transient recovery voltage may be oscillatory or non-oscillatory or a combination of these, depending on the characteristics of the circuit and the circuit-breaker. It includes the voltage shift of the neutral of a polyphase circuit.

(b) The transient recovery voltage in three-phase circuits is, unless otherwise stated, the voltage across the first pole to clear because this voltage is generally higher than that which appears across each of the other two poles.

Trip-free circuit-breaker: A circuit-breaker in which the automatic release mechanism will, under fault conditions, open the contacts of the circuit-breaker independently of the means used to close the contacts and will ensure that the contacts are not held closed against a condition where tripping should occur.

Tripping: The opening of a circuit-breaker either manually or automatically.

Tripping time: The interval of time between the application of a steady overcurrent and the interruption of the circuit.

Voltage: When applied to an alternating current circuit, the root-mean-square value of the voltage.

3. DESIGN AND CONSTRUCTION.

3.1 **STANDARD OF WORKMANSHIP AND FINISH:** All work shall be properly executed and finished and shall be so arranged as not to constitute a hazard.

3.2 **MOULDED CASE:** The operating mechanism of a circuit-breaker shall be contained in a moulded case made of a non-combustible insulating material that will not allow the escape of flame or molten metal through the openings surrounding the operating toggle.

3.3 PROTECTION.

3.3.1 Live parts of a circuit-breaker intended for open surface mounting shall be protected against inadvertent contact by means of acceptably strong covers of insulating material.

3.3.2 Live parts on the underside of a circuit-breaker designed for mounting on a surface shall—

- (a) be covered by a shield or barrier or insulating material; or
- (b) be countersunk at least 3 mm below the surface of its base and covered with a waterproof insulating sealing compound that will not flow during any of the tests specified in Section 6; or
- (c) have a minimum clearance of 6 mm from the mounting surface and be riveted, upset or otherwise acceptably prevented from loosening.

3.4 **CLEARANCES AND CREEPAGE DISTANCES:** All clearances and creepage distances shall be as large as is practicable and, in order to break the continuity of conducting deposits that may form, creepages shall, wherever practicable, incorporate ridges.

3.5 **MOUNTING:** Each circuit-breaker shall have at least two holes for mounting purposes or an alternative method of mounting that will ensure acceptable stability.

3.6 MODE OF OPERATION.

3.6.1 A circuit-breaker shall be arranged for manual closing and opening and for automatic tripping. The mechanism shall be trip-free.

3.6.2 The actuating mechanism shall be such that when a circuit-breaker is mounted in the normal manner, the contacts cannot close by themselves as a result of failure of the mechanism.

Note: The mounting of a circuit-breaker on a vertical plane with its major axis vertical or horizontal shall be considered as mounted in the normal manner.

3.6.3 The tripping of a circuit-breaker under any conditions within its ratings shall not cause the contacts that break the circuit to bounce or show any tendency to reclose.

3.7 **ARC SHIELDS:** Means shall be provided to ensure that when a multipole circuit-breaker operates, there is no arcing between the poles.

3.8 **TRIP INDICATION:** A circuit-breaker shall be so designed that when it has been tripped, a clear indication to that effect is visible to the user.

3.9 TERMINALS.

3.9.1 A circuit-breaker shall be provided with suitable terminals for the connection of copper conductors of the size given in column 2 of Table 1, appropriate to the current rating of the circuit-breaker. The terminals of a circuit-breaker with an intermediate rating shall accommodate conductors of the nominal cross sectional area specified for the next higher current rating.

TABLE 1—WIRING TERMINALS (COPPER CONDUCTORS)

1	2
Rated current of circuit-breaker, A	PVC-covered copper conductor quantity and nominal cross-sectional area, mm ² , min.
Part 1	
Not exceeding 10.....	2 × 1,5
16.....	2 × 4,0
20.....	2 × 4,0
25.....	2 × 4,0
31,5.....	2 × 6,0
40.....	10,0
50.....	16,0
63.....	25,0
80.....	35,0
100.....	50,0
125.....	70,0
160.....	95,0
180.....	95,0
200.....	120
Rated current of circuit-breaker, A	Rectangular bars, finished in matt-black quantity and dimensions, mm, min.*
Part 2	
Not exceeding 224.....	2 × (4 × 16)
250.....	2 × (4 × 16)
315.....	2 × (5 × 20)
355.....	2 × (5 × 25)
400.....	2 × (5 × 31,5)
500.....	2 × (5 × 40)
630.....	2 × (5 × 50)
710.....	2 × (5 × 63)
800.....	2 × (5 × 80)
1 000.....	2 × (5 × 80)

* The spacing between two parallel bars of the same polarity shall be approximately 5 mm.

Where a single connection to two parallel bars is required, the space between the two bars shall be stacked with copper of thickness 5 mm, and of width and length equal to the width of the two bars.

If the bars do not fit the terminals of the circuit-breaker, the dimensions of a copper interconnecting piece (that may be PVC-covered copper cable) shall be supplied by the manufacturer.

- 3.9.2 Terminals shall be so designed that they do not allow the conductors to be displaced and are not themselves displaced in a manner detrimental to the operation of the circuit-breaker or the effectiveness of the insulation [i.e. the minimum prescribed values for clearances and creepage distances specified in 3.3.2 (b) and (c) shall be maintained under all conditions of normal operation of the circuit-breaker].
- 3.9.3 Each terminal for the connection of an external conductor shall be so arranged that it is readily accessible under the intended conditions of use, and an earth terminal (when provided) shall, in addition, be—
- suitably protected against corrosion,
 - permanently and indelibly marked with the symbol \oplus , and
 - of such a size as to accommodate a conductor that complies with the provisions for earth continuity conductors of SABS 0142 'The wiring of premises'.
- 3.9.4 A wiring terminal need not be such as to accept a conductor directly, i.e. without some suitable termination being applied to the conductor, but where a terminal is intended to accommodate a stranded conductor, means shall be provided to prevent the conductor wires from spreading.
- 3.9.5 Each wiring terminal screw shall thread into metal and shall have a smooth clean-cut thread that is free from burrs. The end of the screw shall be so shaped that it will not damage the conductor. Except as allowed below, iron and steel, unless present as a constituent of an alloy that is inherently corrosion resistant, shall not be used for terminals.
- 3.9.6 Terminals of the type in which the external connecting conductors make direct electrical contact with the pole of a circuit-breaker and that are not depended upon to carry the main current of the circuit-breaker, may be of iron or steel that has been plated in an acceptable manner with copper, nickel, cadmium, silver or zinc.
- 3.10 EARTHING. Provision shall be made for the earthing of any exposed metal parts of a circuit-breaker that may become live if the insulation of any part of the circuit-breaker becomes defective (see also 3.9.3).

TABLE 2—CONDUCTOR SIZES FOR TEMPERATURE RISE AND OVERCURRENT RELEASE TESTS (COPPER)

1		2
Rated current of circuit-breaker, A		Conductor nominal cross-sectional of area, mm ²
Part 1		
Not exceeding	10	1,5
	16	2,5
	20	2,5
	25	4
	31,5	6
	40	10
	50	10
	63	16
	80	25
	100	35
	125	50
	160	70
	180	70
	200	95
	224	120
	250	150
	315	185
	355	240
Rated current of circuit-breaker, A		Rectangular bars, quantity and dimensions, mm*
Part 2		
Not exceeding	400	2 × (31,5 × 5)
	500	2 × (40 × 5)
	630	2 × (50 × 5)
	710	2 × (63 × 5)
	800	2 × (80 × 5)
	1 000	2 × (80 × 5)

* The spacing between two parallel bars of the same polarity shall be approximately 5 mm.

Where a single connection to the two parallel bars is required the space between the two bars shall be stacked with copper of thickness 5 mm, a width and length equal to the width of the two bars.

If these bars do not fit the terminals of the circuit-breaker the dimensions of a copper interconnecting piece (that may be PVC/copper cable) shall be supplied by the manufacturer.

4. ELECTRICAL AND PHYSICAL REQUIREMENTS.

4.1 RATINGS. Each circuit-breaker shall be rated in terms of voltage, current, breaking capacity and number of poles.

(a) The breaking capacity of a circuit-breaker used on AC shall be 2,5 kA or 20 times the value of the rated current, whichever is the greater. A circuit-breaker intended for use on both AC and DC shall be rated as having two breaking capacities, one for AC and one for DC.

(b) Unless otherwise marked on the circuit-breaker, the frequency of an a.c. circuit-breaker shall be 50 Hz.

(c) A circuit-breaker shall be single-, double-, or triple- pole and may, when so required, have a neutral pole or a switched neutral.

4.2 INSULATION RESISTANCE: When determined in accordance with 6.3, the insulation resistance of a circuit-breaker shall be at least 10 MΩ.

4.3 UNDERVOLTAGE RELEASE.

4.3.1 When so required, a circuit-breaker shall be provided with an undervoltage release.

4.3.2 A circuit-breaker having an undervoltage release shall, when tested in accordance with 6.4, open even on a slowly falling voltage (1 % per second) at a value of between 70 % and 35 % of the rated voltage of the undervoltage release. The undervoltage release shall prevent closing of the circuit-breaker at a voltage below 35 % and shall not prevent closing at and above 85 % of the rated voltage of the undervoltage release.

4.4 SHUNT RELEASE.

4.4.1 When so required, a circuit-breaker shall be provided with a shunt release having a specific voltage rating or range of voltage ratings.

4.4.2 A circuit-breaker provided with a voltage-operated shunt release shall, when tested in accordance with 6.5, operate on both 70 % and 120 % of the rated voltage of the shunt release.

4.5 OVERCURRENT RELEASE.

4.5.1 General:

4.5.1.1 When so required, a circuit-breaker shall be fitted with an overcurrent release.

4.5.1.2 The overcurrent release shall be of an adjustable or non-adjustable time-delay type or a non-time-delay type.

4.5.1.3 The current-time characteristic of a circuit-breaker shall be that assigned by the manufacturer and marked on the circuit-breaker [see 5.1 (k)].

4.5.2 Time-delay type:

4.5.2.1 A circuit-breaker having a non-adjustable time-delay release shall carry its rated current continuously without tripping but, when tested in accordance with 6.6, shall release automatically within the periods given in Table 3, appropriate to the rated current of the circuit-breaker.

4.5.2.2 An adjustable time-delay release shall be such that, when it is adjusted to its maximum setting, the circuit-breaker will comply with the requirements of 4.5.2.1.

4.5.3 *Non-time-delay type:* A circuit-breaker having a non-time-delay release shall carry its rated current continuously without tripping and, when 135 % of rated current is applied, shall release instantaneously and the arc shall be extinguished within 0,1 seconds.

TABLE 3—OPERATION OF OVERCURRENT RELEASE

1 Rated current (I) A	2	3	4	5	6	7
	Tripping time, max.					
	Percentage of rated current					
	135	200	400	600	1 000	2 000
I ≤ 40	50 min	3 min	25 s	10,0 s	3,5 s	1,0 s
40 < I ≤ 80	100 min	4 min	As stated by the manufacturer			
80 < I ≤ 125	100 min	6 min				
125 < I ≤ 225	100 min	8 min				
225 < I ≤ 400	100 min	10 min				
400 < I ≤ 630	100 min	12 min				
630 < I ≤ 800	100 min	14 min				
800 < I ≤ 1 000	100 min	16 min				

4.6 **OVERLOAD.** When tested in accordance with 6.7, a circuit-breaker shall show no sign on electrical or mechanical failure and no welding, undue burning, or pitting shall occur at the contacts.

4.7 **TEMPERATURE RISE.** When determined in accordance with 6.8, the temperature rise of the insulating material and of each of the parts of a circuit-breaker shall not exceed the relevant value given in Table 4.

TABLE 4—TEMPERATURE RISE

1	2
Parts and types of material*	Temperature rise, °C, max.
(a) Wiring terminals	70
(b) Contacts:	
copper or copper alloys	45
silver	†
silver-tungsten and other sintered metals	‡
(c) Cotton, silk, paper and similar materials, non-impregnated	65
(d) Cotton, silk, paper and similar materials impregnated with a suitable resin, and enamel, when it is used with such materials	80
(e) Wire covered with formaldehyde-, polyvinyl-, or epoxy resin, or polyurethane, when these are not used with fibrous materials	95
(f) Phenolic composition employed as electrical insulation	§80
(g) Mica, glass fibre or asbestos, with binder and impregnation	105
(h) Bare coils	90
(i) Operating toggles (hand-operated)	25

*Other materials not included in this table shall be deemed acceptable if it has been proved that such materials can operate, without adverse effects, at the temperatures attained in service.

†Limited solely by the necessity of not causing any damage to adjacent parts.

‡To be specified according to the properties of the metals and limited by the necessity of not causing any damage to adjacent parts.

§Unless it has been established that the material is acceptable for use at higher temperatures.

- 4.8 **MECHANICAL STRENGTH:** When tested in accordance with 6.10, a circuit-breaker shall show no sign of cracks or permanent deformations.
- 4.9 **BREAKING CAPACITY.**
- 4.9.1. (a) An a.c. circuit-breaker shall be capable of once breaking and once making-and-breaking a circuit adjusted for the prospective current with the relevant power factor given in Table 7, appropriate to the breaking capacity of the circuit-breaker.
- (b) A d.c. circuit-breaker (Class SABS 1,5 kA) shall be capable of once breaking and once making-and-breaking a d.c. circuit with a total inductance of $1 \pm 0,15$ mH and a prospective current of 1 500 A.
- (c) The inherent resetting time of a circuit-breaker shall not exceed 15 minutes.
- 4.9.2 When a circuit-breaker is tested in accordance with 6.9—
- (a) it shall show no sign of electrical or mechanical failure;
- (b) the butter muslin placed over the operating toggles shall not be ignited;
- (c) the average value of the power frequency recovery voltage shall be equal to a value corresponding to 110 % of the rated operational voltage [see 6.9.1 (c)] occurring across the terminals of a pole of the circuit-breaker immediately before the flow of the test current, and this voltage shall be maintained for a period of at least 0,1 seconds after extinction of the arc;
- Note:* This may require that the applied voltage be increased, but the tolerance on the prospective peak making current shall not be exceeded without the consent of the manufacturer;
- (d) there shall be no damage to insulation of conductors used to connect the circuit-breaker in the circuit;
- (e) the fuse connecting metal parts to the neutral of the a.c. power supply or to the negative pole of the d.c. power supply, shall not rupture;
- (f) the circuit-breaker shall still comply with the requirements of 4.5.2. for 200 % of the rated current, or 4.5.3, as applicable; and
- (g) the circuit-breaker shall still be capable of withstanding, for one minute without breakdown, a test voltage of magnitude as given in Table 8, appropriate to the rated voltage of the circuit-breaker.
- 4.10 **NON-COMBUSTIBILITY:** When tested in accordance with 6.12, materials required to be non-combustible shall be incapable of burning or giving off flammable vapours.
5. **MARKING.**
- 5.1 **CIRCUIT-BREAKERS:** The following information shall appear in legible and indelible markings in (unless otherwise required) either or both of the official languages of the Republic of South Africa, either on the body of the circuit-breaker or on a label (see 5.3) securely attached to it, as appropriate:
- (a) The rated current (I_n);
- (b) the "ON" and "OFF" positions of the circuit-breaker either on the operating toggle or on the case, in one of the following ways:
- (1) The symbols | and O for the "ON" and "OFF" positions, respectively; or
- (2) in both official languages, the words "ON" and "OFF" ("AAN" and "AF");
- Note:*
- (i) The "ON" or | marking shall denote that the switch is in the up position.
- (ii) The symbol | used for the "ON" position shall be an upright straight line, not 1 or I.
- Note:* The above markings [(a) and (b)] shall be clearly visible to the operator when the circuit-breaker is mounted as for normal service. If the markings are on the case or on the cover of the circuit-breaker, they shall be adjacent to the operating toggle and visible when the toggle is in the relevant position. Where covers are used for marking, they shall be no-reversible.
- (c) the rated voltage;
- (d) the frequency ratings (if applicable);
- (e) either—
- (1) "AC" (or "~") if the circuit-breaker is intended for use on AC only; or
- (2) "DC" (or "=") if the circuit-breaker is intended for use on DC only; or
- (3) both markings given in (1) and (2) above, together with the relevant voltage ratings if the circuit-breaker is intended for use on both DC and AC;
- (f) when relevant, the voltage rating and the current rating or VA rating of the shunt release, undervoltage release, auxiliary and alarm switches, etc;

- (g) the name, trade name, or registered trade mark of the manufacturer or the supplier;
- (h) a catalogue number of type number or other identification marking that will distinguish the circuit-breaker from any other type marketed by the manufacturer;
- (i) in the case of a circuit-breaker equipped with neutral contacts, the letter N to identify the neutral terminal;
- (j) the breaking capacity class (in kiloamperes) to which the circuit-breaker belongs and in the case of a circuit-breaker having more than one rated breaking capacity, the rated voltage associated with each breaking capacity class;
- (k) the current-time characteristic (this marking may be in code and shall apply to a circuit-breaker fitted with an overcurrent release);
- (l) an acceptable identification mark for the line and load terminals, or alternatively, direction arrows indicating the entry and exit directions of the supply leads where the performance of the circuit-breaker is affected if a reverse connection is made;
- (m) if the circuit-breaker is intended for frequent operation (the current rating being 31,5 A or lower), the symbol "FO".

5.2 The appropriate of the following symbols may also appear in legible and indelible marking on the body of a circuit-breaker:

I_n = rated current

U_n = rated voltage

I_{cn} = rated breaking capacity class, e.g. " $I_{cn} 2,5 \text{ kA}$ "



single-pole thermal magnetic circuit-breaker



single-pole magnetic circuit-breaker



triple-pole thermal magnetic circuit-breaker



triple-pole magnetic circuit-breaker



single-pole and neutral circuit-breaker



single-pole and switched-neutral circuit-breaker

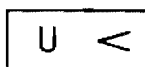

undervoltage relay

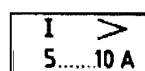

overcurrent relay with a setting range from 5 . . . 10 A

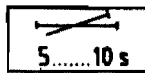

time-lag adjustable from 5 . . . 10 s



shunt trip



auxiliary a-contact



auxiliary b-contact

- 5.3 LABELS: Labels (when used) shall be of acceptable material and when they are tested in accordance with 6.11, the marking shall still be legible and, in the case of a stick-on label, it shall not be possible to remove the label in one piece.
- 5.4 EARTH TERMINALS: Any earth terminal shall be permanently and indelibly marked with the symbol \oplus .
6. INSPECTION AND METHODS OF TEST.
- 6.1 INSPECTION: Visually examine and, when relevant, measure each circuit-breaker for compliance with the relevant requirements of the specification (as given in Sections 3, 4 and 5) for which tests to assess compliance are not given in 6.2–6.3 (inclusive).
- 6.2 GENERAL: For triple-pole circuit-breakers fitted with a neutral pole or a switched neutral pole, carry out each test with the units connected as double-pole circuit-breakers, the poles under test being the neutral pole and the adjacent pole. Use a test voltage equivalent to the phase voltage corresponding to the rated voltage.
- 6.2.1 Unless otherwise required, carry out the tests on each circuitbreaker as a whole and with the ambient temperature maintained at 15–25 °C.
- 6.2.2 Test each single-pole and switched-neutral circuit-breaker, and each single-pole and neutral circuit-breaker, as a double-pole circuit-breaker.
- 6.2.3 With the exception of the air-core reactor in any phase (which shall be shunted by a resistance of a value such that the current through the resistor is 0,6–0,7 % of the current through the air-core reactor), do not connect in parallel the reactance or resistance components of a test circuit load impedance.
- 6.2.4 Except where otherwise specified, use for the test an alternating current supply of practically sinusoidal waveform and that has a frequency of 50 ± 2 Hz. For any test where no tolerances are stated, the following general tolerances shall apply:
- Voltage ± 5 %; Current ± 5 %; Frequency ± 2 Hz; Time ± 5 %.
- 6.3 INSULATION RESISTANCE TEST. Measure at a dc voltage of 500 V the insulation resistance in the following positions:
- (a) Between live terminals and any metal parts that would be exposed when the circuit-breaker is mounted in its normal position. Do this test (with all exposed metal parts electrically connected together) with the circuit-breaker first in the "ON" position and then in the "OFF" position.
 - (b) In the case of multipole circuit-breakers—
 - (1) between each pair of poles, with the circuit-breaker in the "ON" position;
 - (2) between each incoming and each outgoing terminal, with the circuit-breaker in the "OFF" position and with electrical interconnection between—
 - (i) all incoming terminals, and
 - (ii) all outgoing terminals.
- Check for compliance with 4.2.

- 6.4 **UNDERVOLTAGE RELEASE TEST:** Connect the undervoltage release to a power supply operating at its rated voltage. Reduce the voltage at a rate of 1 % per second until the circuit-breaker trips, and record the voltage at this point. Adjust the voltage to 34 % of the rated voltage and try to close the circuit-breaker. Adjust the voltage to 85 % of the rated voltage, close the circuit-breaker and determine whether or not it remains closed at this voltage. Check for compliance with 4.3.2.
- 6.5 **SHUNT RELEASE TEST:** Connect the circuit-breaker to the power supply and determine whether the circuit-breaker trips when the shunt release is energized at a supply voltage of
- (a) 70 %, and
 - (b) 120 %
- of the rated voltage. Check for compliance with 4.4.2.
- 6.6 **OVERCURRENT RELEASE TEST.**
- 6.6.1 *Mounting and connections:* Mount the circuit-breaker as for normal service (with all covers in position) and, using conductors of length at least 1 m and of the size given in Table 2, appropriate to the current rating of the circuit-breaker, connect it to the power supply.
- 6.6.2 *Procedure:*
- (a) Using any convenient voltage, determine the current-time characteristic of the circuit-breaker by operating it at an ambient temperature of $25 \pm 5^\circ\text{C}$ at all the following percentages of rated current:

135	1 000
200	2 000
400	
- Test each pole fitted with an overcurrent release separately except that for calibration at 135 % of the rated current, all poles shall be tested simultaneously and shall be equally loaded. Check for compliance with 4.5.1.3.
- Note:** Where the characteristics of a circuit-breaker are such that the above points do not produce a smooth curve, additional intermediate points may be taken as required.
- (b) Finally, verify the current rating by operating the circuit-breaker at its rated current through all poles simultaneously for at least two hours.
- 6.7 **OVERLOAD TEST.**
- 6.7.1 *Test circuit:* With the circuit-breaker mounted as for normal service connect it into a circuit in which the current has been adjusted to $600 \pm 5\%$ of the relevant rated value and the applied voltage to $110 \pm 5\%$ of the rated voltage of the circuit-breaker. For circuit-breakers other than those for use with AC only, use a d.c. circuit having a total inductance of $1 \pm 0,15$ mH on the load side, and for circuit-breakers for use with AC only, use an a.c. circuit having a lagging power factor of 0,45–0,5.
- 6.7.2 *Procedure:* Unless otherwise required, close and open the circuit-breaker 50 times consecutively at the relevant rate given in column 2 of Table 5 and ensure that the contacts do not remain closed for more than two seconds in each cycle. In the case of multipole circuit-breakers, test simultaneously all poles intended to interrupt current, each pole carrying the current specified above. In the case of a circuit-breaker with no over-current release but fitted with a shunt release, carry out the test as described above but so energize the release (by applying a voltage equal to the rated voltage of the release) that the circuit-breaker opens 20–40 ms after closing.

Check for compliance with 4.6.

TABLE 5—RATE OF OPERATION CYCLES

1	2
Current rating (within the applicable frame size), A	Rate of operation cycles/min
Up to 100.....	6
101–224.....	5
225–630.....	4
631–1 000.....	2

- 6.8 **TEMPERATURE RISE TEST:** Mount the circuit-breaker as for normal service (with all covers in position) in a place where there are no draughts and where the ambient air temperature is 25 ± 5 °C. Using conductors each of length at least 1 m and of the size given in Table 2, appropriate to the current rating of the circuit-breaker, connect the circuit-breaker to the power supply and pass the rated current through the circuit-breaker for a period of two hours or until thermal equilibrium is attained. Then measure the relevant temperature (see Table 4) by means of thermocouples, or any other acceptable method, at the points where the temperatures are judged to be highest. Check for compliance with 4.7.
- 6.9 **BREAKING CAPACITY TEST.**
- 6.9.1 *Power supply:*
- (a) *Alternating current:* A source capable of giving 100 ± 5 % of the relevant prospective current with the corresponding lagging power factor given, any current-limiting impedances used being placed between the circuit-breaker and the power supply.
- (b) *Direct current:* A source capable of giving the prospective current of 1 500 A in a circuit having a total inductance of $1 \pm 0,15$ mH.
- (c) *Voltage:* The voltage of the test circuit immediately before the flow of the test current shall be not less than 105 % and not more than 115 % of the rated voltage of the circuit-breaker.
- 6.9.2 *Mounting:* Mount the circuit-breaker as for normal service and connect it into the test circuit with conductors each of length (on both the load and the line sides) 0,5–0,75 m and of the size given in Table 2, appropriate to the current rating of the circuit-breaker.
- 6.9.3 *Earthing of metal parts:* If the circuit-breaker contains any exposed metal parts or is intended for mounting on a metal plate or support, connect all such metal parts (through a tinned-copper wire fuse of nominal diameter 0,125 mm and of length 75–100 mm) to the neutral wire in the case of a.c. supply or to the negative pole in the case of d.c. supply.
- 6.9.4 *Butter muslin:* Cover that part of the surface of the circuit-breaker in which the operating toggle is situated with clean dry butter muslin that complies with the requirements for Grade 1 butter muslin of SABS 446 'Absorbent gauze (fabric and swabs) and butter muslin'. Ensure that any cut or torn edges of the muslin are not exposed directly to the arc openings where flame may be emitted.
- 6.9.5 *Test circuit:*
- (a) *Single-pole circuit-breaker:* Use a circuit as specified in Fig. 4 or 5.
- (b) *Double-pole, single-pole and neutral, and single-pole and switched-neutral circuit-breakers:* Use a circuit as specified in Fig. 6 or 7.
- (c) *Triple-pole or triple-pole and neutral circuit-breakers:* Use a circuit as specified in Fig. 8.
- (d) *Resistance of voltage measuring circuit:* The value of the resistance of the voltage measuring circuit connected across the terminal of a pole of a circuit-breaker shall be at least 100 Ω per volt of the power-frequency recovery voltage.
- 6.9.6 *Procedure:*
- For all these tests, the live side of the test circuit shall be connected to the corresponding terminals of the circuit-breaker, as marked by the manufacturer. In the absence of such markings, the live side of the test circuit shall be connected to that side of the circuit-breaker which gives the more severe conditions. If there is a doubt as to which is the more severe condition, the circuit-breaker shall be tested in both conditions. New circuit-breakers may be used for each of the two series of tests, or maintenance between the test series is permissible.
- (a) *For AC:*
- (1) With the test circuit adjusted to the appropriate value of voltage, prospective current and power factor as given in Table 6, subject the circuit-breaker to a break test, using point-on-wave switching to obtain the greatest practicable transient current. Maintain the recovery voltage for at least 0,1 second after extinction of the arc. After an interval of not less than two minutes and not more than 15 minutes (the inherent resetting time), subject the circuit-breaker to a make-and-break test, maintaining the recovery voltage for at least 0,1 second after extinction of the arc. During both tests, record by means of an oscillograph or by other acceptable means, the amplitudes and duration of voltage and current.

TABLE 6—VALUES OF PROSPECTIVE CURRENT AND POWER FACTORS FOR BREAKING CAPACITY TEST

1	2	3
Breaking capacity class	Prospective current, symmetrical r.m.s. A	Power factor, lagging
SABS 1,5 kA	1 500 DC	
SABS 2,5 kA	2 500 AC	0,45–0,5
SABS 5 kA	5 000 AC	0,45–0,5
SABS 7,5 kA	7 500 AC	0,45–0,5
SABS 10 kA	10 000 AC	0,45–0,5
SABS 12,5 kA	12 500 AC	0,25–0,3
SABS 15 kA	15 000 AC	0,25–0,3
SABS 20 kA	20 000 AC	0,25–0,3
SABS 25 kA	25 000 AC	0,15–0,2
SABS 30 kA	30 000 AC	0,15–0,2
SABS 35 kA	35 000 AC	0,15–0,2
SABS 45 kA	45 000 AC	0,15–0,2
SABS 55 kA	55 000 AC	0,15–0,2
SABS 75 kA	75 000 AC	0,15–0,2
SABS 100 kA	100 000 AC	0,15–0,2

(2) After the break and make-and-break tests, check the circuit-breaker for compliance with 4.9.2 (a), (b), (d) and (e).

(3) Determine from the oscillograms the power-frequency recovery voltage in accordance with 6.9.7 below, and check for compliance with the requirements of 4.9.2 (c).

(4) Test, in accordance with 6.6.2, the overcurrent release (if fitted) of the circuit-breaker at 135 % or 200 % of the rated current, as applicable, and check for compliance with the requirements of 4.9.2(f).

(5) Finally, apply between the parts listed in 6.3 'Insulation resistance test', an alternating voltage of approximately sinusoidal waveform and of the relevant value given in Table 7.

Start the test at a voltage not exceeding one third of the specified test voltage and increase to its full value as rapidly as is consistent with the true value being indicated by the measuring instrument. Maintain the full test voltage for one minute and then decrease it rapidly to not more than one third of this value before switching off. Check for compliance with the requirements of 4.8.2(g).

(b) For DC:

(1) With the test circuit adjusted to the appropriate values of voltage and a prospective current of 1 500 A subject the circuit-breaker to a break test and maintain the recovery voltage for at least 0,1 second after extinction of the arc. After an interval of not less than two minutes and not more than 15 minutes (the inherent re-setting time), subject the circuit-breaker to a make-and-break test, maintaining the recovery voltage for at least 0,1 second after extinction of the arc. During both tests, record by means of an oscillograph or by other acceptable means, the amplitudes and duration of voltage and current.

Proceed further as for AC using steps (2), (3), (4) and (5) given in (a) above.

TABLE 7—TEST VOLTAGE

1	2
Rated voltage, V	Test voltage, V (r.m.s.)
Not exceeding 250	1 500
Exceeding 250 not exceeding 500	2 000
Exceeding 500 not exceeding 660	2 200
Exceeding 660 not exceeding 1 000	3 000

6.9.7 Interpretation of oscillograms:

(a) *Determination of applied voltage and power-frequency voltage:* From the oscillograms recorded during the calibration of the circuit the break test and the make-and-break test, determine the applied voltage and the power-frequency recovery voltage by estimating these voltages, using the examples as shown in Fig. 1 for AC voltages and Fig. 2 for DC voltages. (Fig. 1 and 2 apply to the make-and-break test).

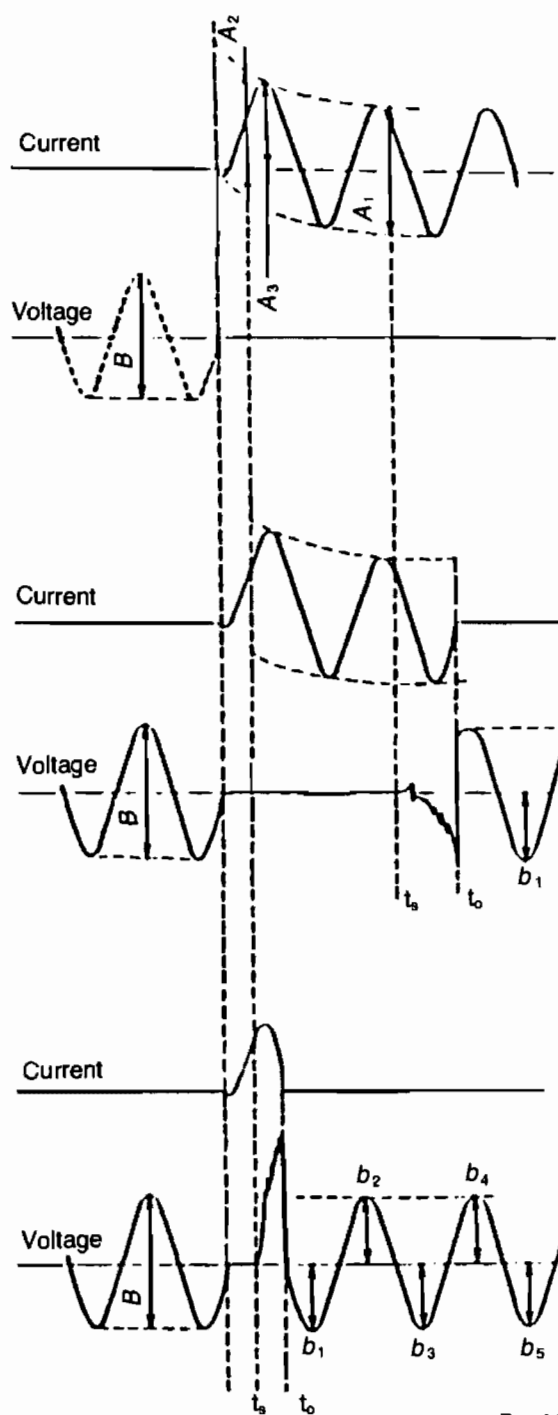

(a) Calibration of the circuit.
 Prospective peak-making current = A_3
 Prospective symmetrical breaking current

$$= \frac{A_2}{2\sqrt{2}} \text{ or } \frac{A_1}{2\sqrt{2}}$$

Applied voltage = B

(b) Oscillogram corresponding to a make-and-break test after the current has reached its peak value.

Short-circuit making capacity:
 Current $I_{peak} = A_3$ at voltage $U_{r.m.s.}$

$$= \frac{B}{2\sqrt{2}}$$

Short-circuit breaking capacity:

Current $I_{r.m.s.} = \frac{A_1}{2\sqrt{2}}$
 at voltage $U_{r.m.s.} = \frac{(b_1 + b_2 + b_3 + b_4 + b_5 + b_6)}{6\sqrt{2}}$

(c) Oscillogram corresponding to a make-and-break test before the current has reached its peak value.

Short-circuit making capacity:
 Current $I_{peak} = A_3$ at voltage $U_{r.m.s.}$

$$= \frac{B}{2\sqrt{2}}$$

 Short-circuit breaking capacity:
 Current $I_{r.m.s.} = \frac{A_2}{2\sqrt{2}}$
 at voltage $U_{r.m.s.} = \frac{(b_1 + b_2 + b_3 + b_4 + b_5 + b_6)}{6\sqrt{2}}$

Drg.11633/E

t_a = Separation of contacts

t_b = Arc extinction

FIG. 1—Verification of Short-circuit Making and Breaking Capacities on AC

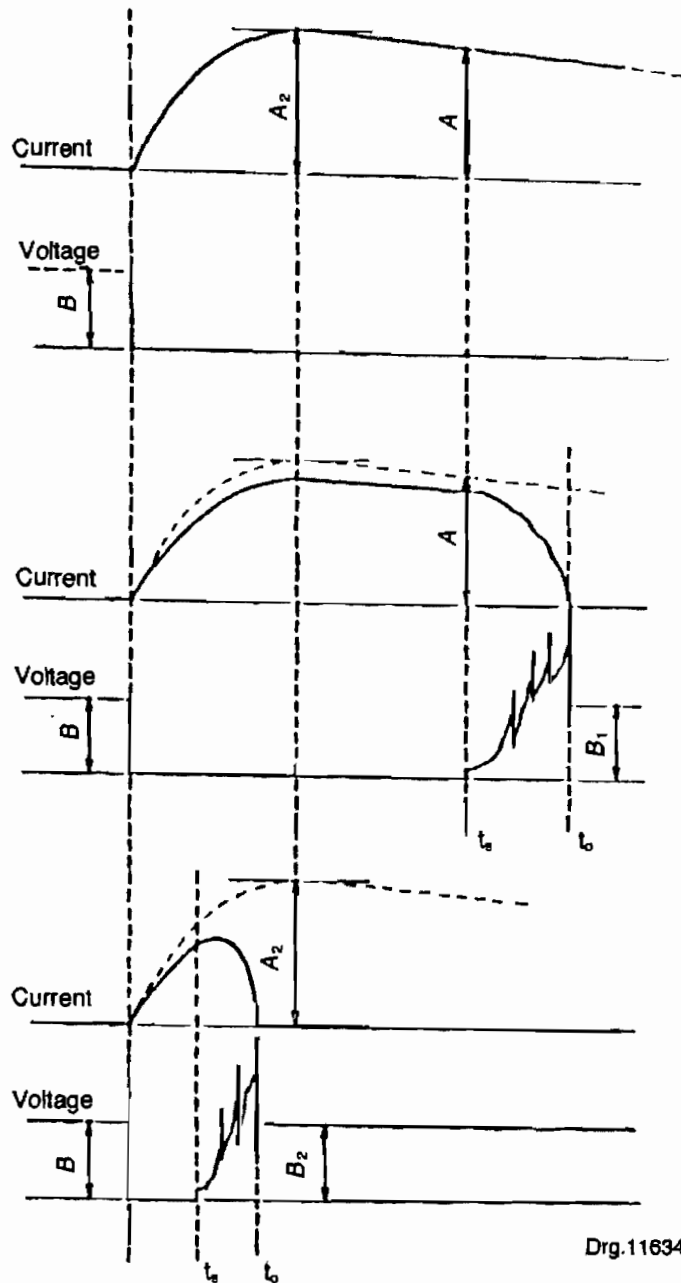

(a) Calibration of the circuit.
 Prospective peak-making current = A_2
 Applied voltage = B

(b) Oscillogram corresponding to a make-and-break test after the current has passed its maximum value.
 Short-circuit breaking capacity:
 Current $I = A$ at voltage $U = B_1$
 Short-circuit making capacity:
 Current $I = A_2$ at voltage $U = B$

(c) Oscillogram corresponding to a make-and-break test before the current has reached its maximum value.
 Short-circuit breaking capacity:
 Current $I = A_2$ at voltage $U = B_2$
 Short-circuit making capacity:
 Current $I = A_2$ at voltage $U = B$

Drg.11634/E

FIG. 2—Verification of Short-circuit Making and Breaking Capacities on DC

Measure the power-frequency voltage during the first half-cycle (without transients) after extinction of the arc, and during the next five successive peaks. Take the sum of these six peaks divided by $6\sqrt{2}$ as the r.m.s. power-frequency recovery voltage for each phase as shown in Fig. 1 (b) and (c), and check for compliance with 4.9.2.(c).

Note: Attention is drawn to the fact that because of the influence of—

- (1) short time variations in the insulation resistance of a circuit-breaker,
- (2) short time variations in the insulation resistance of arc gaps, or
- (3) the resistance in recovery voltage measuring circuits, or any combination of these, certain types of triple-pole circuit-breaker exhibit a tendency for the power-frequency recover voltage across each pole of the circuit-breaker to undergo short time variations in amplitude that fall below 105 % and rise above 115 % of the rated voltage of the circuit-breaker. Other types of triple-pole circuit-breaker have been observed to exhibit erratic short time variations in the power-frequency recovery voltage during which the amplitude varies from approximately zero value to full recovery voltage across one pole, while the recovery voltage across the other two poles shows short time variations in amplitude from above to below the specified limits. Where doubt exists regarding compliance of the circuit-breaker with the requirements for power-frequency recovery voltage, take three additional circuit-breakers and subject them to the break and make-and-break tests in accordance with the procedure given in 6.9.6 above, but with the neutral of the source of supply being connected to the common earth connection (Point F in Fig. 8).

(b) *Determination of the prospective breaking current:* For AC, determine the value of the prospective breaking current by comparing the current trace obtained in the calibration of the circuit [see Fig. 1 (a)] with that obtained during the break test (the oscillogram of which is not shown in Fig. 1), or that obtained in the make-and-break test [see Fig. 1 (b)]. Take the prospective breaking current in each phase to be the value of the r.m.s. power-frequency component of the calibration current that corresponds to the instant of separation of the arcing contacts [values corresponding to A_1 or A_2 of Fig. 1 (a)]. Ensure that the prospective current in any one phase does not differ from the average value by more than 10 %.

For DC take the value of the prospective breaking current as being equal to the maximum value A_2 as determined from the calibration curve for circuit-breakers breaking before the current has reached its maximum value, and equal to the value A for circuit-breakers breaking after the current has passed its maximum value (as shown in Fig. 2) during the make-and-break test or during the break test (not shown in Fig. 2).

(c) *Determination of the prospective peak-making current:* Determine the peak-making current from the calibration oscillogram and take its value as being equal to A_3 for AC [see Fig. 1 (a)] and to A_2 for DC [see Fig. 2 (a)]. In the case of a three-phase test, take the highest of the A_3 values obtained from the oscillogram.

Note: For tests on single-pole circuit-breakers, attention is drawn to the fact that the prospective peak-making current determined from the calibration oscillogram may differ from the value of the prospective peak-making current corresponding to the test, depending on the instant of making.

6.10 MECHANICAL STRENGTH TEST.

6.10.1 Apparatus:

(a) *A mechanical strength test apparatus* as shown in Fig. 3. The metal cylinder A of mass 250 g and of outer diameter 25 mm fits loosely over the guide rod B. The guide rod is not rigidly fixed to the frame of the test apparatus and can be easily slid up and down. A hard fibre washer C of diameter 25 mm and of thickness 12,5 mm is fixed to the bottom end of the guide rod.

(b) *A rectangular hardwood block D* that fits on the base of the test apparatus.

6.10.2 Specimen: Use one circuit-breaker from the sample.

6.10.3 Procedure:

(a) Place the hardwood block on the base of the test apparatus and firmly hold or otherwise mount the specimen on the block with its mounting surface down (i.e. toggle uppermost).

(b) Raise the guide rod and so move the block that, when the guide rod is lowered, the fibre washer rests on the surface of the specimen. Lower the guide rod, raise the metal cylinder to a height of 250 mm above the fibre washer, and allow the cylinder to drop onto the fibre washer.

(c) Repeat the drop twice, ensuring that the toggle is subjected to one drop when it is in the OFF position.

(d) So turn the specimen that it lies on its side on the block and proceed as described in (b) above, subjecting the specimen to three drops, two at random (but not on an edge of the specimen) and one approximately in the middle of the terminal guard.

(e) Turn the specimen onto the other side and repeat the procedure given in (d) above.

(f) After the specimen has been subjected to the nine drops, examine it for compliance with 4.8.

6.11 TEST FOR LEGIBILITY OF LABELS AND ADHERENCE OF STICK-ON LABELS.

6.11.1 *Preparation of Specimens:* Condition three circuit-breakers in a ventilated oven at 70 ± 2 °C for a period of 168 ± 2 h. In the case of a stick-on label within three minutes after removing each circuit-breaker from the oven, peel back the label for approximately a quarter of its length (without removing the remainder of the label from its original position). Allow the circuitbreaker to cool (for at least four hours) to room temperature before carrying out the test described below.

6.11.2 *Procedure:*

(a) *All labels:* Soak a piece of butter muslin, that complies with the requirements of SABS 446 'Absorbent gauze (fabric and swabs) and butter muslin' for Grade 1 butter muslin in tap water and, applying a pressure of 0,05–0,1 MPa, rub the muslin over the markings on the label, a total of 30 times in each direction (forward and reverse). Repeat the test with butter muslin soaked in petroleum spirit and then examine the markings and check for compliance with 5.3.

(b) *Stick-on labels:* Using a spring balance and a suitable clamp attached to the free end of the label (see 6.11.1), try to remove the label from the circuit-breaker by pulling the free end with a force of 0,15–0,18 N/mm width of the label for a period of five seconds in a direction at right angles to the surface of the label.

Check for compliance with 5.3.

6.12 COMBUSTION TEST.

6.12.1 *Test specimens:* From the appropriate parts of the circuitbreaker, prepare at least three test specimens of width approximately 12 mm, of length approximately 50 mm and of thickness approximately 12 mm. (If the thickness of the material is greater than 12 mm, cut the specimens to a thickness of 12 mm.)

6.12.2 *Conditioning:* Condition the specimens for a period of at least 18 h in an atmosphere having a relative humidity of 75 ± 5 % and a temperature of 20 ± 2 °C. Test every specimen within 3 minutes after removing it from the controlled atmosphere.

6.12.3 *Apparatus:* A test oven having a heating chamber as shown in Fig. 9. The area of the opening at the top of the conical cover is approximately 700 mm² and the total area of the air intake holes at the bottom of the oven is approximately 70 mm². A light stirrup of wire may be used to support the specimen, the support being so arranged that the specimen is held centrally in the heating chamber, with its longest dimension vertical, and its upper end approximately 70 mm below the pilot flame. The apparatus is heated by passing a suitably regulated electric current through a heating element surrounding the heating chamber.

6.12.4 *Temperature measurement:* Take as the temperature of the heating chamber that shown by a thermocouple situated at the level of the middle of the specimen and equidistant from the inner surface of the chamber and the specimen.

6.12.5 *Procedure:* Suspend the specimen in the heating chamber and, keeping the specimen and pilot flame under observation, raise the temperature of the heating chamber to 300 ± 5 °C and maintain this temperature for a period of five minutes. Report as defective any specimen that burns or gives off flammable vapours that ignite at the pilot flame.

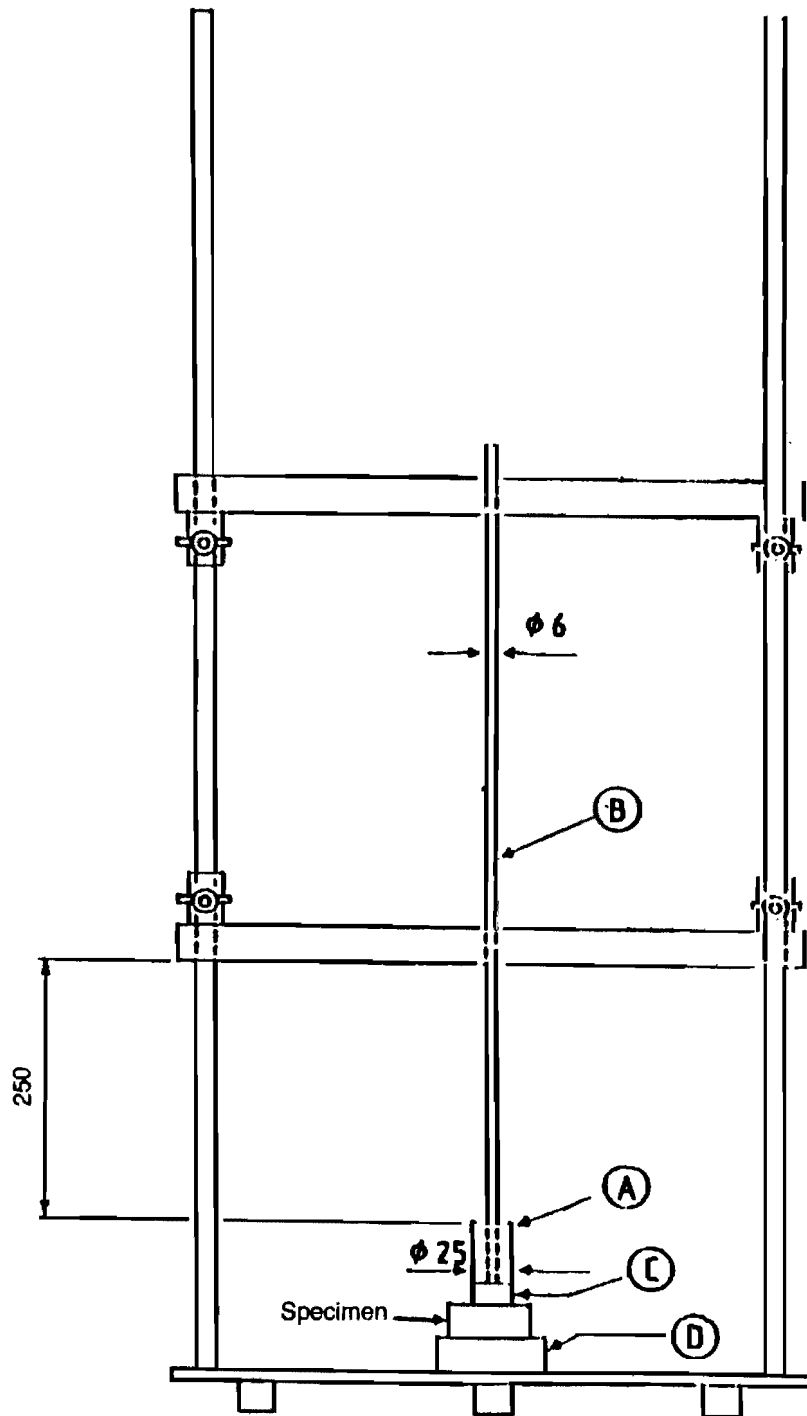

Dimensions in millimetres

Drg. 11632/E

FIG.3—Apparatus for Mechanical Strength Test

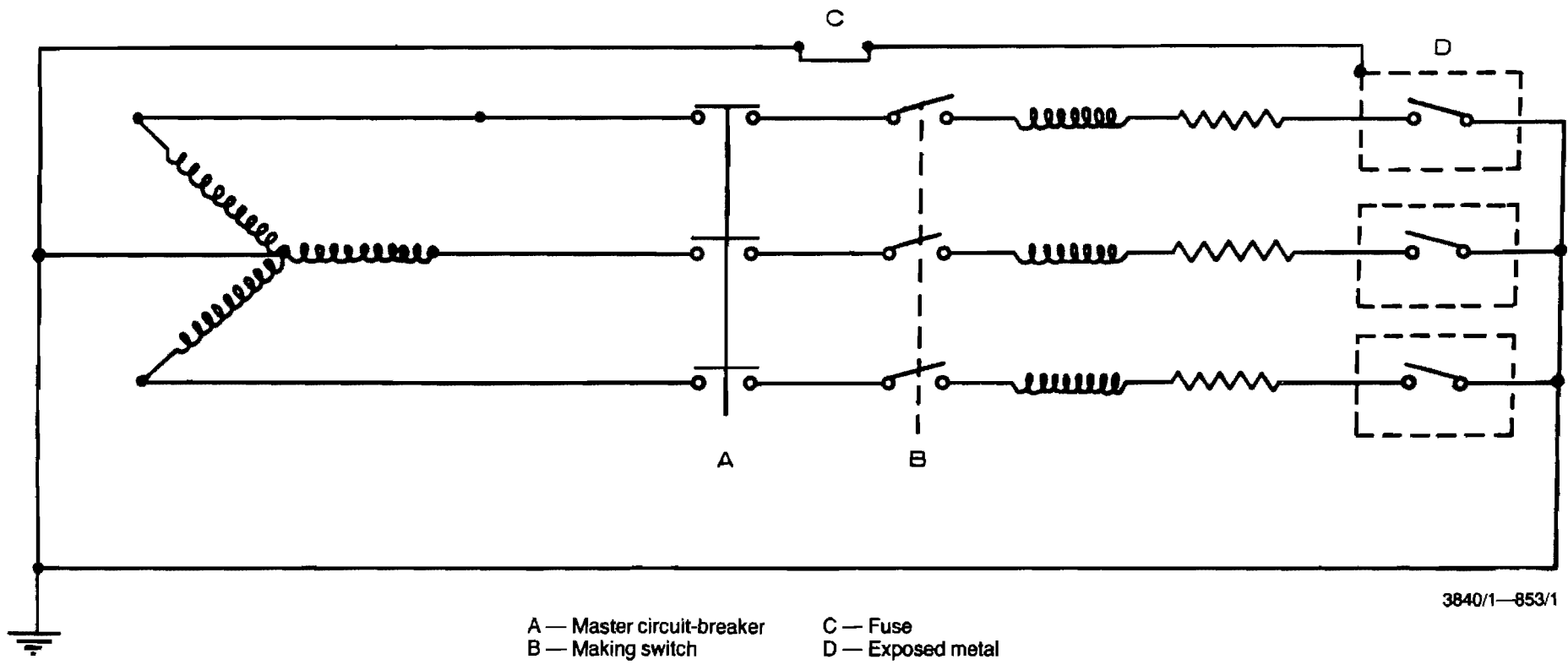
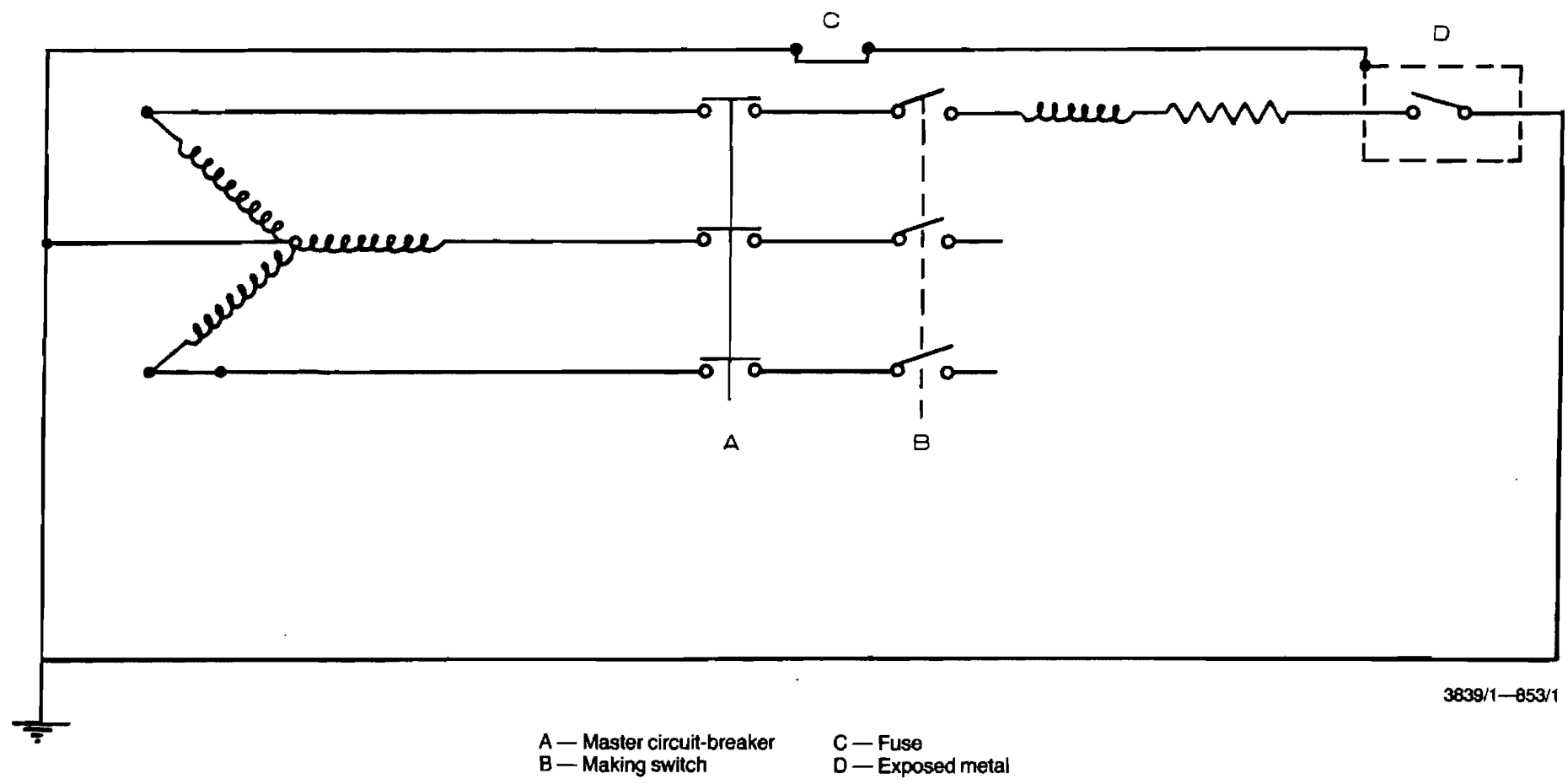

FIG. 4—Circuit Diagram for Breaking Capacity Test on Single-pole Circuit-breakers



3839/1—853/1

FIG. 5—Alternative Circuit Diagram for Breaking Capacity Test on Single-pole Circuit-breakers

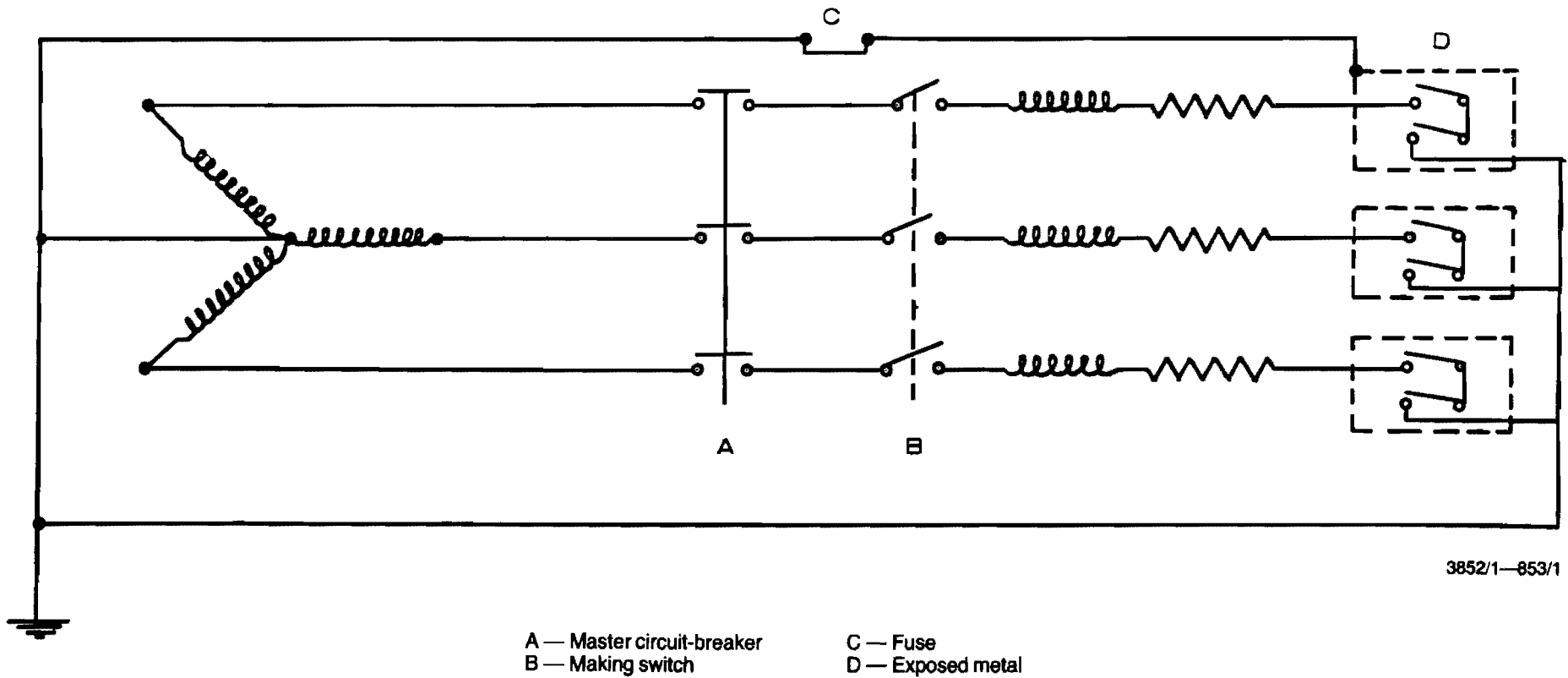
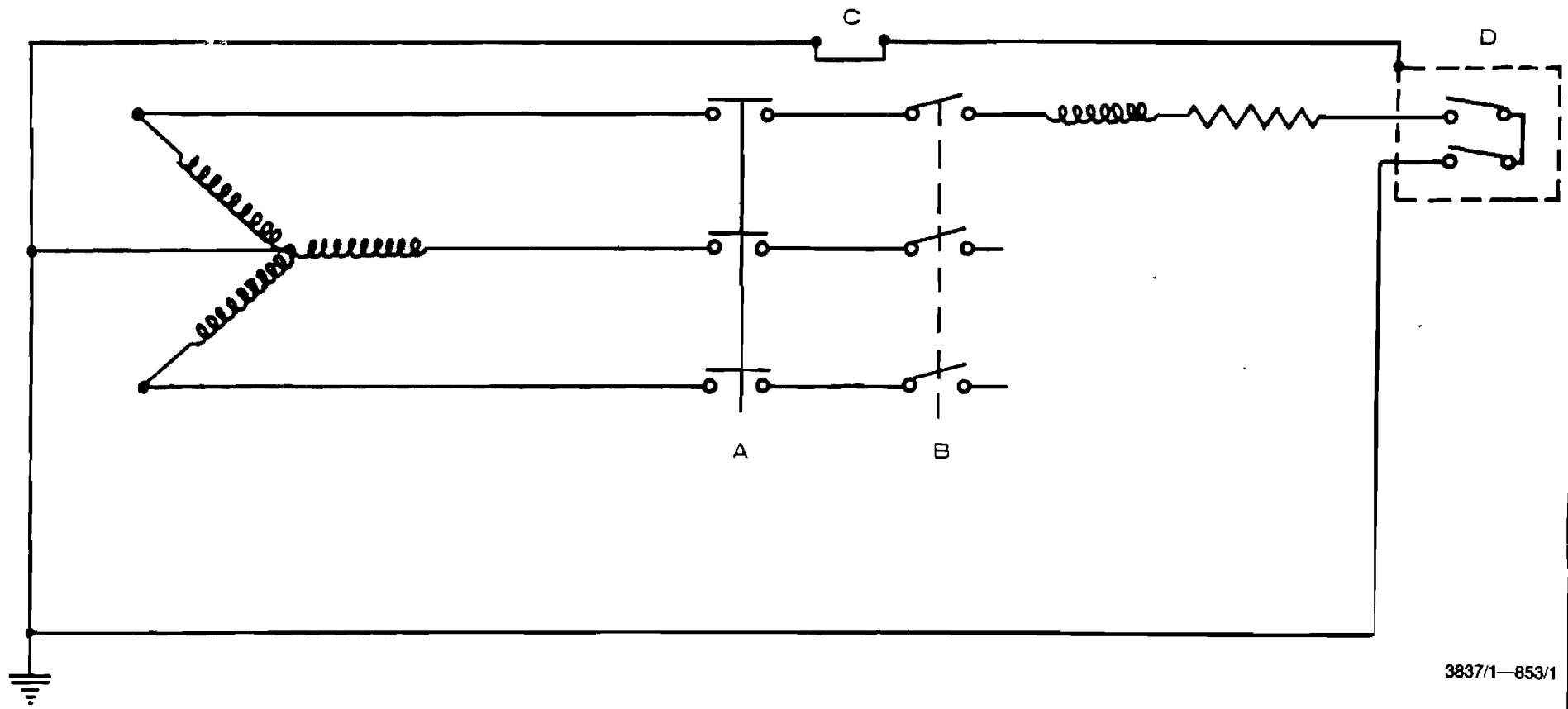

FIG. 6—Circuit Diagram for Breaking Capacity Test on Double-pole Circuit-breakers



A — Master circuit-breaker
B — Making switch

C — Fuse
D — Exposed metal

FIG. 7—Alternative Circuit Diagram for Breaking Capacity Test on Double-pole Circuit-breakers

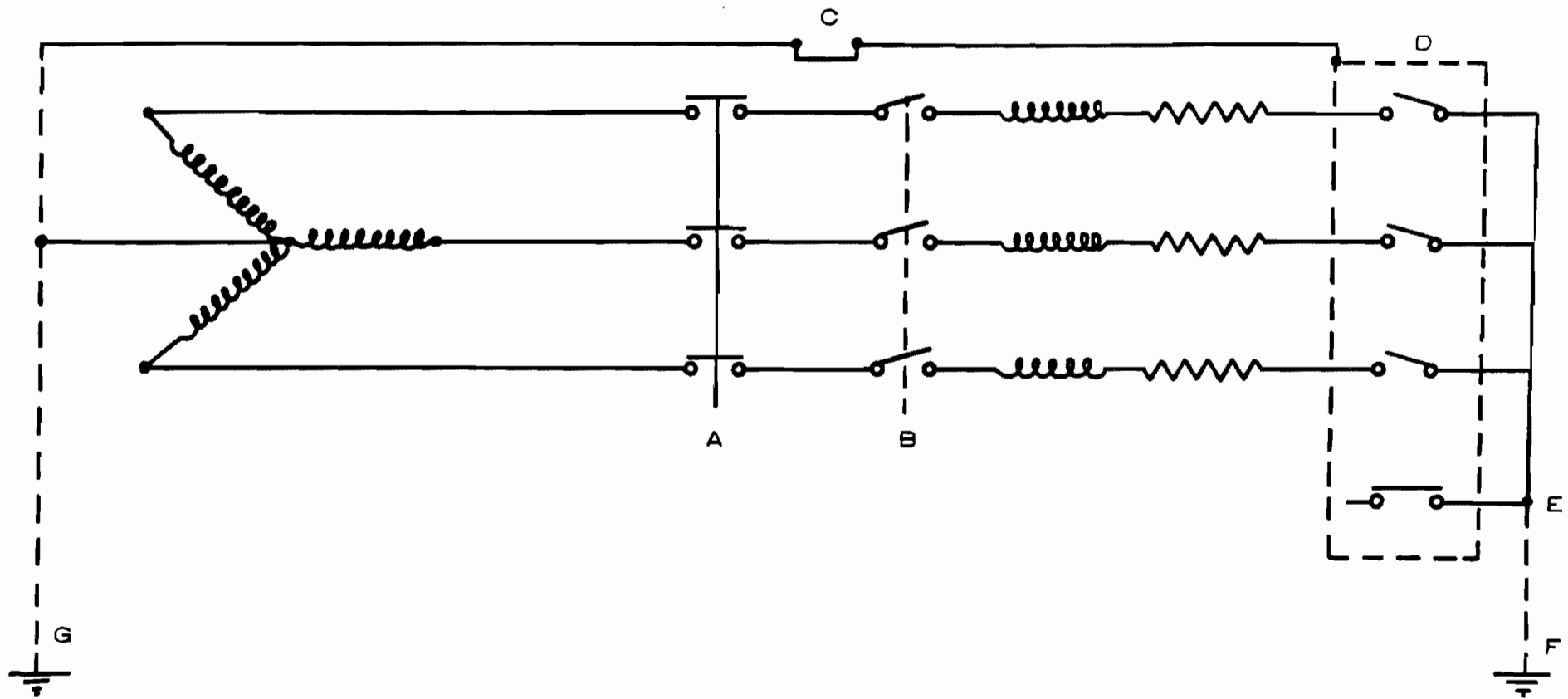

- | | |
|----------------------------|--------------------------------------|
| A — Master circuit-breaker | D — Exposed metal |
| B — Making switch | E — Neutral link |
| C — Fuse | F, G — Alternative earth connections |

FIG. 8—Circuit Diagram for Breaking Capacity Test on Triple-pole Circuit-breakers

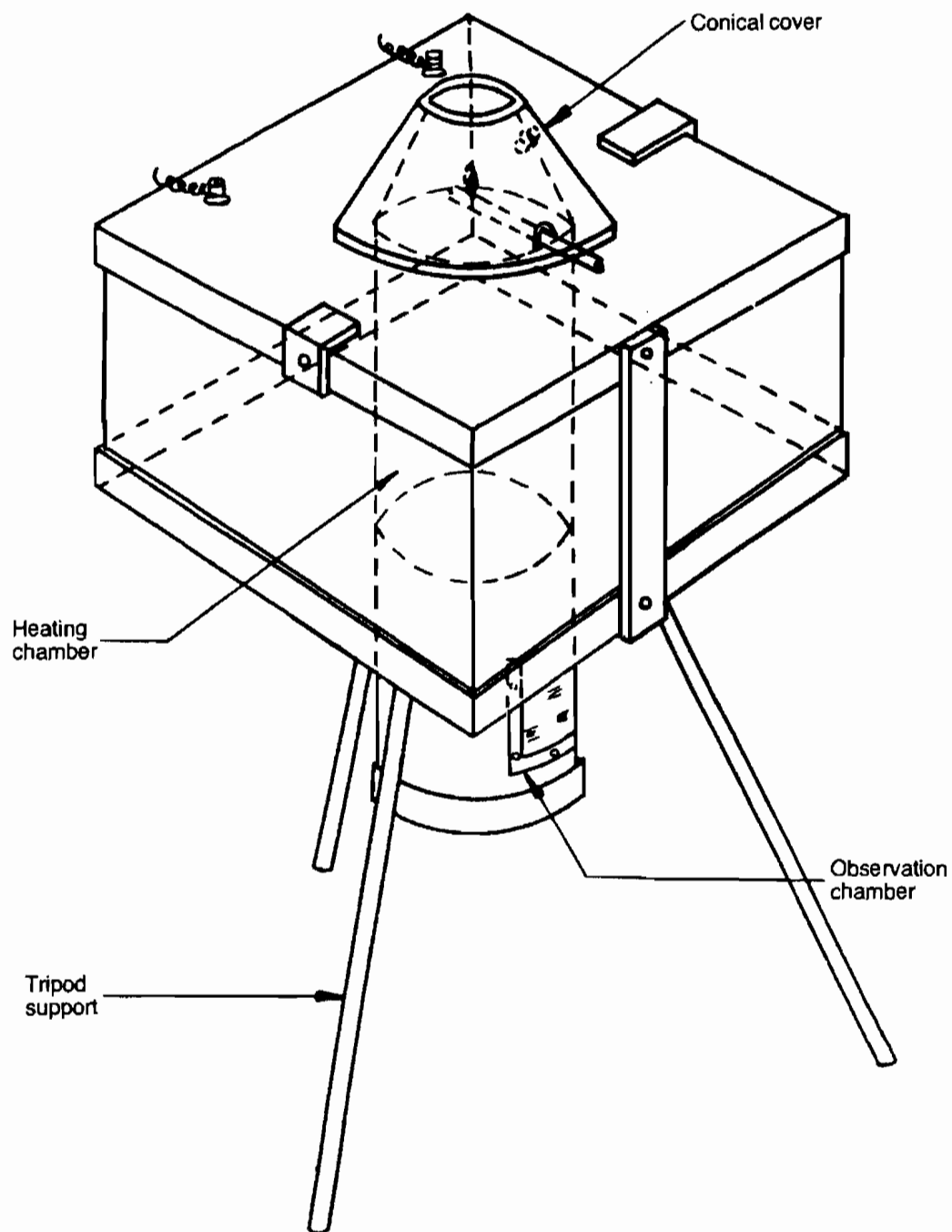

1668/1—37/1

FIG. 9 (a)—Sketch of Assembled Apparatus

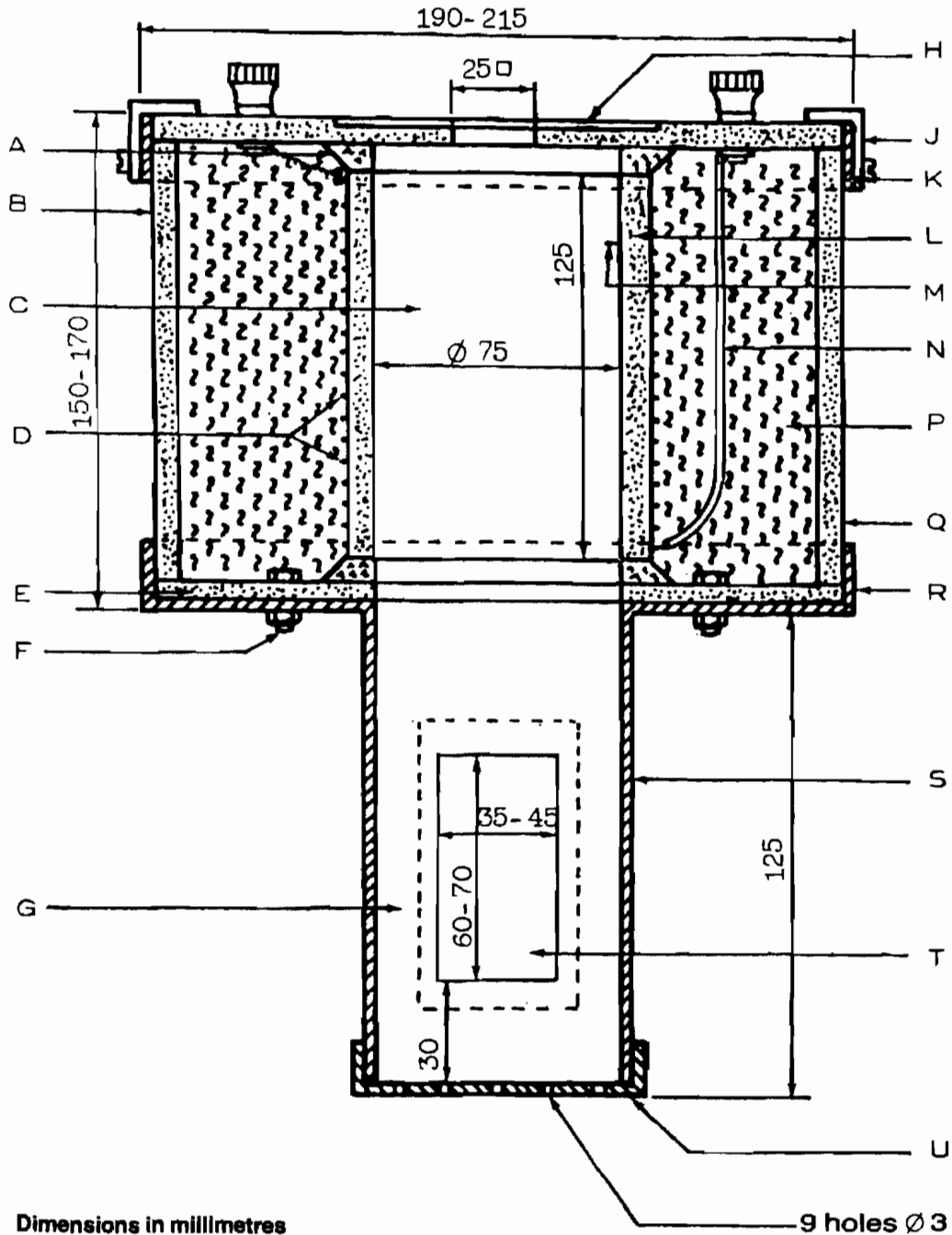

Dimensions in millimetres

1669/2-37/2

- | | |
|---------------------------------------|---|
| A—Refractory cement | K—Metal band |
| B—Asbestos cement sheet | L—Fireclay or silica tube |
| C—Heating chamber | M—Thermocouple |
| D—Nichrome element | N—Heat-resisting insulation |
| E—Asbestos board | P—Packing of asbestos wool or magnesia asbestos |
| F—Brass bolt | Q—Asbestos cement sheet |
| G—Observation chamber | R—Angle iron |
| H—Recess for placing of conical cover | S—Metal cylinder |
| J—Metal clip | T—Mica window |
| | U—Screw-on or sliding-fit cap |

FIG. 9 (b)—Details of Oven

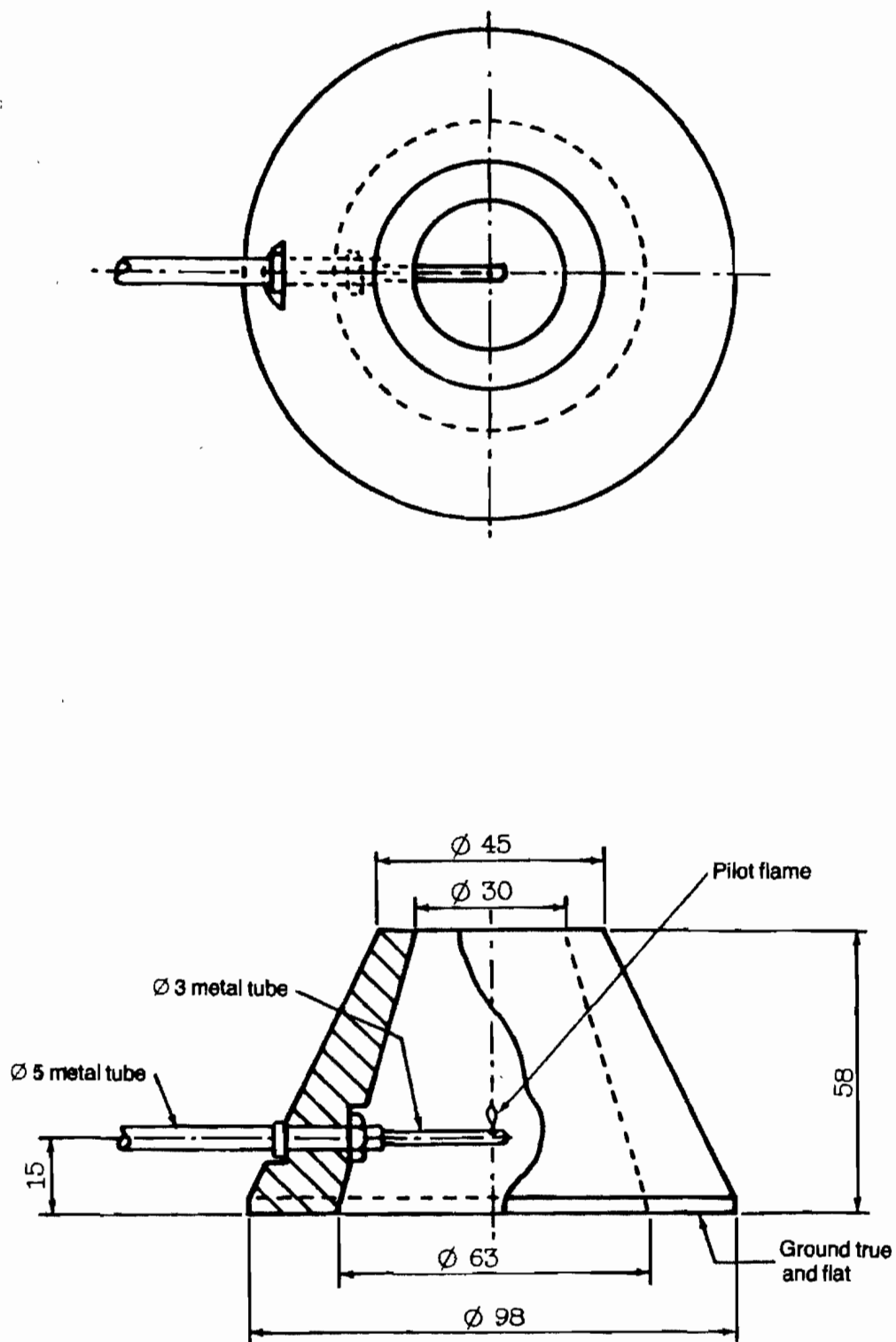

Dimensions in millimetres

1670/2—37/2

FIG. 9 (c)—Details of Conical Cover

DEPARTEMENT VAN JUSTISIE

No. 2318 16 Oktober 1987

**SLUITING VAN DIE LOCKSTRAATGEVANGENIS
(OOS-LONDEN)**

Dit het die Minister van Justisie behaag om sy goedkeuring te heg aan die sluiting van die Lockstraatgevangenis (Oos-Londen).

**DEPARTEMENT VAN LANDBOU-
EKONOMIE EN -BEMARKING**

No. 2315 16 Oktober 1987

**KOÖPERASIE WAT VAN DIE REGISTER GESKRAP
IS.—KUBOES KOÖPERATIEWE HANDELSVERENIGING
BEPERK**

Hiermee word bekendgemaak dat die naam van bogenoemde koöperasie op 24 September 1987 ingevolge die bepaling van artikel 44 (b) van die Koöperasiewet, 1981, van die register geskrap is.

N. F. PIENAAR,
Registrateur van Koöperasies.

**DEPARTEMENT VAN MINERAAL- EN
ENERGIESAKE**

No. 2275 16 Oktober 1987

**UITHOU VAN GROND VIR DIE DOELEINDES VAN 'N
OPENBARE PAD**

Die Mynkommissaris vir die myndistrik Nigel het 'n strook geproklameerde grond op die plaas Vlakfontein 161 IR, distrik Nigel, myndistrik Heidelberg, provinsie Transvaal, soos getoon op 'n sketskaart waarvan afdrucke onder RMT R21/80 in die Mynbriewekantoor, Johannesburg, en in die kantoor van die Mynkommissaris, Johannesburg, bewaar word, kragtens artikel 179 (1) (b) van die Wet op Mynregte, 1967 (Wet 20 van 1967), vir die doeleindes van 'n openbare pad uitgehou.

(19/5/1999)

No. 2276 16 Oktober 1987

VOORGENOME DEPROKLAMERING VAN GROND

Die Staatspresident is voornemens om kragtens die bevoegdheid hom verleen by artikel 44 van die Wet op Mynregte, 1967 (Wet 20 van 1967), die grond beskryf in bygaande Bylae en getoon op 'n sketskaart waarvan afdrucke onder RMT R9/87 in die Mynbriewekantoor, Johannesburg, en in die kantoor van die Mynkommissaris, Pietersburg, bewaar word, as openbare delwery vir onedele minerale te deproklameer.

BYLAE

<i>Beskrywing van grond</i>	<i>Grootte</i>	<i>Geregistreeerde eienaar</i>
Gedeelte 1 van die plaas Riet 182 MT	23,4905 hektaar	Izak Johannes van Rooyen.
Die plaas Stayt 183 MT, distrik Messina, myndistrik Pietersburg, Provinsie Transvaal	1 184,2782 hektaar	Izak Johannes van Rooyen.

SCHEDULE

<i>Description of land</i>	<i>Extent</i>	<i>Registered owner</i>
Portion 1 of the farm Riet 182 MT	23,4905 hectares	Izak Johannes van Rooyen.
The farm Stayt 183 MT, District of Messina, Mining District of Pietersburg, Province of the Transvaal	1 184,2782 hectares	Izak Johannes van Rooyen.

DEPARTMENT OF JUSTICE

No. 2318 16 October 1987

**CLOSING OF THE LOCK STREET PRISON
(EAST LONDON)**

The Minister of Justice has been pleased to approve the closing of the Lock Street Prison (East London).

**DEPARTMENT OF AGRICULTURAL
ECONOMICS AND MARKETING**

No. 2315 16 October 1987

**CO-OPERATIVE REMOVED FROM REGISTER.—
KUBOES KOÖPERATIEWE HANDELSVERENIGING
BEPERK**

Notice is hereby given that the name of the abovementioned co-operative was removed from the register on 24 September 1987 in terms of section 44 (b) of the Co-operatives Act, 1981.

N. F. PIENAAR,
Registrar of Co-operatives.

**DEPARTMENT OF MINERAL AND
ENERGY AFFAIRS**

No. 2275 16 October 1987

**RESERVATION OF LAND FOR THE PURPOSE OF A
PUBLIC ROAD**

The Mining Commissioner for the Mining District of Nigel has, in terms of section 179 (1) (b) of the Mining Rights Act, 1967, (Act 20 of 1967), reserved for the purpose of a public road a strip of proclaimed land on the farm Vlakfontein 161 IR, District of Nigel, Mining District of Heidelberg, Province of the Transvaal, as shown on a sketch plan, copies of which have been filed under RMT R21/86 in the Mining Titles Office, Johannesburg, and in the office of the Mining Commissioner, Johannesburg.

(19/5/1999)

No. 2276 16 October 1987

PROPOSED DEPROCLAMATION OF LAND

It is the intention of the State President, under and by virtue of the powers vested in him by section 44 of the Mining Rights Act, 1967 (Act 20 of 1967), to deproclaim as a public digging for base minerals the land described in the attached Schedule and shown on a sketch plan, copies of which are filed in the Mining Titles Office, Johannesburg, and in the office of the Mining Commissioner, Pietersburg, under RMT R9/87.

DEPARTEMENT VAN NASIONALE OPVOEDING

No. 2273 16 Oktober 1987

WET OP NASIONALE GEDENKWAARDIGHEDE,
No. 28 VAN 1969

BERGINGSPERMIT

Ingevolge artikel 12 (2c) (c) van die Wet op Nasionale Gedenkwaardighede, 1969 (Wet 28 van 1969), bied die Raad vir Nasionale Gedenkwaardighede hierby geleentheid vir die rig van vertoë tot hom oor die uitreiking van 'n bergingspermit vir die Hollandse driemasseilskip *Padang*, ook bekend as *Penang*, wat op 28 Junie 1828 in die Valsbaaigebied naby Muizenberg gestrand het.

Sodanige vertoë moet die Raad vir Nasionale Gedenkwaardighede, Posbus 4637, Kaapstad, 8000, binne drie weke vanaf die datum van publikasie van hierdie kennisgewing bereik.

C. J. LOEDOLFF,
Direkteur: Raad vir Nasionale Gedenkwaardighede.

DEPARTEMENT VAN OMGEWINGSAKE

No. 2277 16 Oktober 1987

TRANSVAAL NASIONALE BOTANIESE TUIN.—
VERANDERING VAN NAAM

Kragtens die bevoegdheid my verleen by artikel 66 (4) (b) van die Boswet, 1984 (Wet 122 van 1984), saamgelees met artikels 46 en 47 van die Wet op die Oordrag van Bevoegdheede en Pligte van die Staatspresident, 1986 (Wet 97 van 1986), wysig ek hierby Bylae 1 van die Boswet, 1984, deur die naam van die Transvaal Nasionale Botaniese Tuin te verander na die Witwatersrand Nasionale Botaniese Tuin.

G. J. KOTZÉ,
Minister van Omgewingsake.

No. 2291 16 Oktober 1987

INTREKKING VAN DIE INSTELLING VAN DIE
PAARL - FRANSCHHOEK - BRANDBEHEERGEBIED
EN -BRANDBEHEERKOMITEE

Kragtens die bevoegdheid my verleen by artikel 19 (5) (a) (ii) van die Boswet, 1984 (Wet 122 van 1984), trek ek, Gert Jeremias Kotzé, Minister van Omgewingsake en van Waterwese, die instelling van die Paarl-Franschhoek-brandbeheergebied en -brandbeheerkomitee, soos gepubliseer by Goewermenskennisgewing 252 van 11 Februarie 1955, hierby in.

G. J. KOTZÉ,
Minister van Omgewingsake en van Waterwese.

No. 2292 16 Oktober 1987

INTREKKING VAN DIE INSTELLING VAN DIE
RAWSONVILLE - BRANDBEHEERGEBIED EN
BRANDBEHEERKOMITEE

Kragtens die bevoegdheid my verleen by artikel 19 (5) (a) (ii) van die Boswet, 1984 (Wet 122 van 1984), trek ek, Gert Jeremias Kotzé, Minister van Omgewingsake en van Waterwese, die instelling van die Rawsonville-brandbeheergebied en -brandbeheerkomitee, soos gepubliseer by Goewermenskennisgewing 252 van 11 Februarie 1955, hierby in.

G. J. KOTZÉ,
Minister van Omgewingsake en van Waterwese.

DEPARTMENT OF NATIONAL EDUCATION

No. 2273 16 October 1987

NATIONAL MONUMENTS ACT,
No. 28 OF 1969

SALVAGE PERMIT

In terms of section 12 (2c) (c) of the National Monuments Act, 1969 (Act 28 of 1969), the National Monuments Council hereby invites representations on the issuing of a salvage permit for the Dutch barque *Padang*, also known as *Penang*, which sank on 28 June 1828 in the False Bay area near Muizenberg.

Such representations should reach the National Monuments Council, P.O. Box 4637, Cape Town, 8000, within three weeks from the date of publication of this notice.

C. J. LOEDOLFF,
Director: National Monuments Council.

DEPARTMENT OF ENVIRONMENT AFFAIRS

No. 2277 16 October 1987

TRANSVAAL NATIONAL BOTANIC GARDEN.—
CHANGE OF NAME

Under and by virtue of the powers vested in me by section 66 (4) (b) of the Forest Act, 1984 (Act 122 of 1984), read in conjunction with sections 46 and 47 of the Transfer of Powers and Duties of the State President Act, 1986 (Act 97 of 1986), I hereby amend Schedule 1 of the Forest Act, 1984, by changing the name of the Transvaal National Botanic Garden to the Witwatersrand National Botanic Garden.

G. J. KOTZÉ,
Minister of Environment Affairs.

No. 2291 16 October 1987

ABROGATION OF THE ESTABLISHMENT OF THE
PAARL-FRANSCHHOEK FIRE CONTROL AREA AND
FIRE CONTROL COMMITTEE

Under the powers vested in me by section 19 (5) (a) (ii) of the Forest Act, 1984 (Act 122 of 1984), I, Gert Jeremias Kotzé, Minister of Environment Affairs and of Water Affairs hereby abrogate the establishment of the Paarl-Franschhoek Fire Control Area and Fire Control Committee as published by Government Notice 252 dated 11 February 1955.

G. J. KOTZÉ,
Minister of Environment Affairs and of Water Affairs.

No. 2292 16 October 1987

ABROGATION OF THE ESTABLISHMENT OF THE
RAWSONVILLE FIRE CONTROL AREA AND FIRE
CONTROL COMMITTEE

Under the powers vested in me by section 19 (5) (a) (ii) of the Forest Act, 1984 (Act 122 of 1984), I, Gert Jeremias Kotzé, Minister of Environment Affairs and of Water Affairs hereby abrogate the establishment of the Rawsonville Fire Control Area and Fire Control Committee as published by Government Notice 252 dated 11 February 1955.

G. J. KOTZÉ,
Minister of Environment Affairs and of Water Affairs.

DEPARTEMENT VAN ONTWIKKELINGSBEPLANNING
DEPARTMENT OF DEVELOPMENT PLANNING

No. 2278

16 Oktober/October 1987

STAAT VAN INVORDERINGS VAN PROVINSIALE INKOMSTE (INSLUITEND DIREKTE INVORDERINGS DEUR PROVINSIES) VAN 1 APRIL 1987 TOT 30 JUNIE 1987
STATEMENT OF PROVINCIAL REVENUE COLLECTIONS (INCLUDING COLLECTIONS DIRECT BY PROVINCES) FROM 1 APRIL 1987 TO 30 JUNE 1987

Hoofde van Inkomste Head of Revenue	Kaap die Goeie Hoop Cape of Good Hope		Natal		Transvaal		Oranje-Vrystaat Orange Free State		Totale Totals	
	1/6/87- 30/6/87	1/4/87- 30/6/87	1/6/87- 30/6/87	1/4/87- 30/6/87	1/6/87- 30/6/87	1/4/87- 30/6/87	1/6/87- 30/6/87	1/4/87- 30/6/87	1/6/87- 30/6/87	1/4/87- 30/6/87
<i>Bronne van Inkomste oorgedra/Sources of Revenue transferred</i>	R	R	R	R	R	R	R	R	R	R
Lisensies/Licences										
Hond, Vis en Wild/Dog, Fish and Game	58 699	106 051	31 428	115 030	164 253	365 461	48 997	155 637	303 377	742 179
Motorvoertuie/Motor Vehicles.....	5 763 627	17 165 351	6 067 906	17 637 327	15 478 363	46 961 602	360 418	1 260 582	27 670 314	83 024 862
Diverse/Miscellaneous										
Hospitaalontvangste/Hospital Receipts	6 912 367	19 498 653	2 750 376	7 551 212	8 066 632	15 357 493	1 865 260	3 837 927	19 594 635	46 245 285
Ander Ontvangste/Other Receipts	3 110 960	7 543 175	727 045	3 301 824	9 642 996	14 645 318	836 100	2 484 816	14 317 101	27 975 133
Boetes en Verbeurdverklarings/Fines and Forfeitures.....	1 654	2 420	505 877	1 398 778	3 296 461	7 962 431	408 934	1 185 983	4 212 926	10 549 612
Venduregte/Auction Dues	—	—	—	—	—	—	34 496	151 860	34 496	151 860
Belasting op Vermaaklikheid/Entertainment Tax ...	—	—	—	—	—	—	1 618	4 832	1 618	4 832
Belasting op Wedrenne en Weddenskappe/Racing and Betting Taxation	—	100	1 928 994	5 002 899	5 592 003	16 636 584	570 033	1 976 296	8 091 030	23 615 879
Wielbelasting en Bydraes/Wheel Tax	—	—	—	—	—	—	1 533	1 533	1 533	1 533
Swart Hospitaalbelasting en Bydraes/Black Hospital Tax and Contributions	—	—	—	—	—	—	664	2 627	664	2 627
Totale/Totals.....R	15 847 307	44 315 750	12 011 626	35 007 070	42 240 708	101 928 889	4 128 053	11 062 093	74 227 694	192 313 802
Totale/Totals (1986/87).....R	16 502 616	45 456 694	10 377 450	32 277 313	24 106 324	87 482 943	4 054 857	11 043 427	55 041 247	176 260 377

E. G. DE BEER,

Direkteur-generaal: Departement van Ontwikkelingsbeplanning.
 Director-General: Department of Development Planning.

GOVERNMENT GAZETTE, 16 OCTOBER 1987

No. 10987 121

No. 2328**16 Oktober 1987****AANWYSING EN AFSONDERING VAN GROND AS 'N ONTWIKKELINGSGBIED IN DIE DISTRIK BOKSBURG**

Ek, Petrus Johannes Badenhorst, handelende namens en in opdrag van die Minister van Staatkundige Ontwikkeling en Beplanning, maak hierby ingevolge artikel 33 (3) van die Wet op die Ontwikkeling van Swart Gemeenskappe, 1984 (Wet 4 van 1984), soos gewysig, bekend dat die grond in die Bylae hiervan omskryf ingevolge artikel 33 (1) van genoemde Wet as 'n ontwikkelingsgebied aangewys is.

P. J. BADENHORST,

Adjunk-minister van Ontwikkelingsbeplanning.

(Leër A6/5/2/B53)

BYLAE

'n Sekere stuk grond, 14,1665 ha groot, synde Gedeelte 186 ('n gedeelte van Gedeelte 183) van die plaas Vlakplaats 138 IR, Transvaal, soos aangetoon op LG-diagram 68/82.

No. 2329**16 Oktober 1987****AANWYSING EN AFSONDERING VAN GROND AS 'N ONTWIKKELINGSGBIED IN DIE DISTRIK BOKSBURG**

Ek, Petrus Johannes Badenhorst, handelende namens en in opdrag van die Minister van Staatkundige Ontwikkeling en Beplanning, maak hierby ingevolge artikel 33 (3) van die Wet op die Ontwikkeling van Swart Gemeenskappe, 1984 (Wet 4 van 1984), soos gewysig, bekend dat die grond in die Bylae hiervan omskryf ingevolge artikel 33 (1) van genoemde Wet as 'n ontwikkelingsgebied aangewys is.

P. J. BADENHORST,

Adjunk-minister van Ontwikkelingsbeplanning.

(Leër A6/5/2/B53)

BYLAE

'n Sekere stuk grond, 151,8099 ha groot, synde Gedeelte 220 van die plaas Vlakplaats 138 IR, Transvaal, soos aangetoon op LG-diagram 5648/87.

No. 2330**16 Oktober 1987****AANWYSING EN AFSONDERING VAN GROND AS 'N ONTWIKKELINGSGBIED IN DIE DISTRIK BOKSBURG**

Ek, Petrus Johannes Badenhorst, handelende namens en in opdrag van die Minister van Staatkundige Ontwikkeling en Beplanning, maak hierby ingevolge artikel 33 (3) van die Wet op die Ontwikkeling van Swart Gemeenskappe, 1984 (Wet 4 van 1984), soos gewysig, bekend dat die grond in die Bylae hiervan omskryf ingevolge artikel 33 (1) van genoemde Wet as 'n ontwikkelingsgebied aangewys is.

P. J. BADENHORST,

Adjunk-minister van Ontwikkelingsbeplanning.

(Leër A6/5/2/B53)

BYLAE

- (i) 'n Sekere stuk grond, 31,2280 ha groot, synde die Restant van Gedeelte 61 ('n gedeelte van Gedeelte 7) van die plaas Vlakplaats 138 IR, Transvaal, soos aangetoon op LG-diagram 3109/42; en
- (ii) 'n sekere stuk grond, 41,2000 ha groot, synde die Restant van Gedeelte 62 ('n gedeelte van Gedeelte 7) van die plaas Vlakplaats 138 IR, Transvaal, soos aangetoon op LG-diagram 3110/42.

No. 2328**16 October 1987****DESIGNATION AND SETTING ASIDE OF LAND AS A DEVELOPMENT AREA IN THE DISTRICT OF BOKSBURG**

I, Petrus Johannes Badenhorst, acting on behalf and by direction of the Minister of Constitutional Development and Planning, do hereby in terms of section 33 (3) of the Black Communities Development Act, 1984 (Act 4 of 1984), as amended, make known that the land defined in the Schedule hereto has been designated as a development area in terms of section 33 (1) of the said Act.

P. J. BADENHORST,

Deputy Minister of Development Planning.

(File A6/5/2/B53)

SCHEDULE

A certain area of land, 14,1665 ha in extent, being Portion 186 (a portion of Portion 183) of the farm Vlakplaats 138 IR, Transvaal, as shown on Diagram SG 68/82.

No. 2329**16 October 1987****DESIGNATION AND SETTING ASIDE OF LAND AS A DEVELOPMENT AREA IN THE DISTRICT OF BOKSBURG**

I, Petrus Johannes Badenhorst, acting on behalf and by direction of the Minister of Constitutional Development and Planning, do hereby in terms of section 33 (3) of the Black Communities Development Act, 1984 (Act 4 of 1984), as amended, make known that the land defined in the Schedule hereto has been designated as a development area in terms of section 33 (1) of the said Act.

P. J. BADENHORST,

Deputy Minister of Development Planning.

(File A6/5/2/B53)

SCHEDULE

A certain area of land 151,8099 ha in extent, being Portion 220 of the farm Vlakplaats 138 IR, Transvaal, as shown on Diagram SG 5648/87.

No. 2330**16 October 1987****DESIGNATION AND SETTING ASIDE OF LAND AS A DEVELOPMENT AREA IN THE DISTRICT OF BOKSBURG**

I, Petrus Johannes Badenhorst, acting on behalf and by direction of the Minister of Constitutional Development and Planning, do hereby in terms of section 33 (3) of the Black Communities Development Act, 1984 (Act 4 of 1984), as amended, make known that the land defined in the Schedule hereto has been designated as a development area in terms of section 33 (1) of the said Act.

P. J. BADENHORST,

Deputy Minister of Development Planning.

(File A6/5/2/B53)

SCHEDULE

- (i) A certain area of land, 31,2280 ha in extent, being Remainder of Portion 61 (a portion of Portion 7) of the farm Vlakplaats 138 IR, Transvaal, as shown on Diagram SG 3109/42; and
- (ii) a certain area of land, 41,2000 ha in extent, being Remainder of Portion 62 (a portion of Portion 7) of the farm Vlakplaats 138 IR, Transvaal, as shown on Diagram SG 3110/42.

DEPARTEMENT VAN WATERWESE

No. 2335

16 Oktober 1987

BREËRIVIER - STAATSWATERBEHEERGEBIED, AFDELINGS WORCESTER, ROBERTSON, SWELLEN-DAM EN MONTAGU, KAAPPROVINSIE.—UITBREI-DING VAN GRENSE

Ek, Jacob Albertus van Wyk, Adjunk-minister van Waterwese, handelende namens die Minister van Waterwese kragtens die bevoegdheid hom verleen by artikel 59 (1) van die Waterwet, 1956 (Wet 54 van 1956), verklaar hierby dat die grense van die Breërivier-staatswaterbeheergebied met ingang van die datum van publikasie hiervan vir doeleindes van artikel 59 (1) (a) en (b) van gemelde Wet uitgebrei word sodat die eiendomme in die Bylae hiervan uiteengesit, by genoemde Staatswaterbeheergebied ingesluit word.

J. A. VAN WYK,
Adjunk-minister van Waterwese.

BYLAE

DIE EIENDOMME WAT DIE UITBREIDING VAN DIE BREËRIVIER - STAATSWATERBEHEERGEBIED, GELEË IN DIE AFDELINGS WORCESTER, ROBERTSON, SWELLEN-DAM EN MONTAGU, KAAPPROVINSIE, UITMAAK

Die volgende plase met alle onderverdelings:

Afdeling Worcester

Draaivlei 492.
Modder Rivier 499.
Plaas 527.
Hermitage 528.
Kweek Kraal 530.
Stettyn 531.
Plaas 532.
Stettyn Zuid 533.
De Hoek 534.
De Hoek 536.
Roodeberg 537.
Moddergat 538.
Moddergat 539.
Moddergat 540.
Moddergat 541.
Hammans Berg 543.
Lemoenpoort 545.
Doom Rivier 546.
Gedeelte 4 van Zandrivier 550.
De Doorns 552.
Plaas 600.
Bellevue 635.
Lemoenpoort 641.
Plaas 662.

Afdeling Robertson

Babbedas Berg 3.
Norree 11.
Kruispad 12.
Norree 13.
Diep Kloof 14.
Resterende Gedeelte en Gedeelte 16 van De Hoop 23.
La Fontaine 24.

DEPARTMENT OF WATER AFFAIRS

No. 2335

16 October 1987

BREEDE RIVER GOVERNMENT WATER CONTROL AREA, DIVISIONS OF WORCESTER, ROBERTSON, SWELLEN-DAM AND MONTAGU, CAPE PROVINCE.—EXTENSION OF BOUNDARIES

I, Jacob Albertus van Wyk, Deputy Minister of Water Affairs, acting on behalf of the Minister of Water Affairs by virtue of the powers vested in him by section 59 (1) of the Water Act, 1956 (Act 54 of 1956), hereby declare that, with effect from the date of publication hereof, the boundaries of the Breede River Government Water Control Area shall for the purpose of section 59 (1) (a) and (b) of the said Act, be extended so as to include the properties specified in the Annexure hereto in the said Government Water Control Area.

J. A. VAN WYK,
Deputy Minister of Water Affairs.

ANNEXURE

THE PROPERTIES COMPRISING THE EXTENSION OF THE BREEDE RIVER GOVERNMENT WATER CONTROL AREA, SITUATED IN THE DIVISIONS OF WORCESTER, ROBERTSON, SWELLEN-DAM AND MONTAGU, CAPE PROVINCE

The following farms with all subdivisions:

Divisions of Worcester

Draaivlei 492.
Modder Rivier 499.
Farm 527.
Hermitage 528.
Kweek Kraal 530.
Stettyn 531.
Farm 532.
Stettyn Zuid 533.
De Hoek 534.
De Hoek 536.
Roodeberg 537.
Moddergat 538.
Moddergat 539.
Moddergat 540.
Moddergat 541.
Hammans Berg 543.
Lemoenpoort 545.
Doom Rivier 546.
Portion 4 of Zandrivier 550.
De Doorns 552.
Farm 600.
Bellevue 635.
Lemoenpoort 641.
Farm 662.

Division of Robertson

Babbedas Berg 3.
Norree 11.
Kruispad 12.
Norree 13.
Diep Kloof 14.
Remaining Extent and Portion 16 of De Hoop 23.
La Fontaine 24.

Gedeeltes 4, 5, 6 en 7 van Aasvogelnest 43.
 Gedeelte 2 van Klaas Voogds Rivier 44.
 Klip Hoogte 46.
 Roodehoogte 47.
 De Hex Rivier 50.
 Gannabosch Vlakte 51.
 Resterende Gedeelte van Lange Vallei 52.
 Klipbosch Laagte 113.
 Bakens Hoogte 114.
 Gedeelte 3 van Wel Van Pas 137.
 Gedeelte 33 van Oude Kraal 170.
 Bo Eike 205.
 Voorspoed Annex 206.

Afdeling Swellendam

Resterende Gedeelte van Gedeelte 1, Gedeelte 8 van Gedeelte 12 van Riet Fontein 175.
 Resterende Gedeelte van Horrees Drift 208.
 Taaibos 531.

Afdeling Montagu

Resterende Gedeelte van Gedeelte 3 van Goree 158.
 Die volgende erwe:

Munisipale gebied van Ashton

Resterende Gedeelte van Erf 551.
 Erf 658.

Portions 4, 5, 6 and 7 of Aasvogelnest 43.
 Portion 2 of Klaas Voogds Rivier 44.
 Klip Hoogte 46.
 Roodehoogte 47.
 De Hex Rivier 50.
 Gannabosch Vlakte 51.
 Remaining Extent of Lange Vallei 52.
 Klipbosch Laagte 113.
 Bakens Hoogte 114.
 Portion 3 of Wel Van Pas 137.
 Portion 33 of Oude Kraal 170.
 Bo Eike 205.
 Voorspoed Annex 206.

Division of Swellendam

Remaining Extent of Portion 1, Portion 8 and Portion 12 of Riet Fontein 175.
 Remaining Extent of Horrees Drift 208.
 Taaibos 531.

Division of Montagu

Remaining Extent of Portion 3 of Goree 158.
 The following erven:

Municipal Area of Ashton

Remaining Extent of Erf 551.
 Erf 658.

No. 2336

16 Oktober 1987

BREËRIVIER - STAATSWATERBEHEERGEBIED.—
BEPALING INGEVOLGE ARTIKEL 63 (2B) VAN DIE
WATERWET, 1956, VAN DIE MAKSIMUM OMVANG
VAN GROND WAT BYKOMEND BY DIË BEPAAL
INGEVOLGE ARTIKEL 63 (2) VAN GENOEMDE WET,
BESPROEI KAN WORD

Ek, Jacob Albertus van Wyk, Adjunk-minister van Waterwese, handelende namens die Minister van Waterwese kragtens die bevoegdheid hom verleen by artikel 63 (2B) van die Waterwet, 1956 (Wet 54 van 1956), bepaal hierby dat, ten opsigte van die eiendomme wat binne die Breërivier-staatswaterbeheergebied geleë is, die maksimum reg op bykomende inlysting wat ingevolge hierdie kennisgewing aangekoop mag word, 140 ha per eienaar is: Met dien verstande dat—

- (1) van voormelde maksimum reg op bykomende inlysting enige inlysting afgetrek word wat toegestaan is of kan word ingevolge Bepalingskennisgewing 309 van 21 Februarie 1986 ten opsigte van al die eiendomme waarvan die applikant op die datum van hierdie kennisgewing die geregistreerde eienaar is; en
- (2) hierdie bepaling aan die volgende voorwaardes onderworpe is en aansoek ooreenkomstig die prosedure hierin voorgeskryf, gedoen word:
 - (a) 'n Toekenning geskied aan 'n applikant ten opsigte van—
 - (i) sy eiendomme soos dit op die datum van hierdie kennisgewing in die Aktekantoor geregistreer is, uitgesonderd enige sodanige eiendom(me) of gedeelte(s) daarvan wat op genoemde datum reeds by wyse van 'n koopkontrak afverkoop is, maar ten opsigte waarvan oordrag nog nie gegee is nie; en

No. 2336

16 October 1987

BREED RIVER GOVERNMENT WATER CONTROL
AREA.—DETERMINATION IN TERMS OF SECTION
63 (2B) OF THE WATER ACT, 1956, OF THE MAXI-
MUM EXTENT OF LAND THAT MAY BE IRRIGATED
IN ADDITION TO THAT DETERMINED IN TERMS OF
SECTION 63 (2) OF THE SAID ACT

I, Jacob Albertus van Wyk, Deputy Minister of Water Affairs, acting on behalf of the Minister of Water Affairs by virtue of the powers vested in him by section 63 (2B) of the Water Act, 1956 (Act 54 of 1956), hereby determine that, in respect of properties situated within the Breede River Government Water Control Area, the maximum right to additional scheduling that may be purchased in terms of this notice shall be 140 ha per owner: Provided that—

- (1) from the said maximum right to additional scheduling any scheduling shall be deducted which has been or can still be allocated in terms of Determination Notice 309 of 21 February 1986 in respect of all the properties of which the applicant is the registered owner on the date of this notice; and
- (2) this determination shall be subject to the following conditions and applications shall be made in accordance with the procedure prescribed herein:
 - (a) An allocation shall be made to an applicant in respect of—
 - (i) his properties as registered in the Deeds Office at the date of this notice, except any such property(ies) or portion(s) thereof which has or have already been sold by means of a deed of sale on the said date but in respect of which transfer has not yet been given; and

- (ii) eiendom(me) wat hy gekoop het by wyse van 'n koopkontrak gesluit voor genoemde datum, maar waarvan oordrag nog nie geneem is nie: Met dien verstande dat registrasie daarvan op sy naam afgehandel word voor of op 31 Maart 1991 of sodanige latere datum as wat ek ten opsigte van 'n bepaalde geval bepaal,
- en is slegs benutbaar in die mate waarin dit ingevolge paragraaf (2) (h) hieronder opgeneem is in die lys bedoel in artikel 64 (6) van die Waterwet, 1956, ten opsigte van die Breërivierstaatswaterbeheergebied.
- (b) 'n Toekenning word gedoen met inagneming van die omvang van besproeibare grond op 'n bepaalde eiendom soos vasgestel deur die Departement van Landbou en Watervoorsiening of deur 'n ander persoon of instansie wat in opdrag van genoemde Departement optree, in welke geval die ondersoek in dié verband op koste van die aansoeker geskied en die bevinding van so 'n persoon of instansie onderworpe is aan die goedkeuring van genoemde Departement.
- (c) Ek behou my die reg voor om, niesteenstaande die beskikbaarheid van besproeibare grond soos deur die Departement van Landbou en Watervoorsiening bepaal of goedgekeur, in 'n bepaalde geval van die aansoeker te vereis om ook bevredigende bewys voor te lê dat die onderhawige grond ekonomies besproei kan word.
- (d) In die geval van 'n eiendom in paragraaf (2) (a) (ii) bedoel, moet die betrokke koopkontrak uitdruklik bepaal hoe enige bestaande inlysting ingevolge Bepalingskennisgewing 309 van 21 Februarie 1986 ten opsigte van die oorspronklike eiendom aan die verskillende onderverdelings wat daaruit sal ontstaan, toegewys word.
- (e) 'n Aansoek om 'n toekenning word oorweeg slegs van 'n persoon wat regsbevoeg is ten opsigte van die betrokke eiendom en bewys daarvan moet die aansoek vergesel: Met dien verstande dat waar die aansoeker nie die geregistreerde eienaar is nie, enige toekenning wat kragtens hierdie kennisgewing toegestaan word, nie in die lys bedoel in artikel 64 (6) van die Waterwet ten opsigte van die Breërivierstaatswaterbeheergebied opgeneem word alvorens die registrasie van die eiendom in die betrokke aktekantoor ooreenkomstig die bewese regsbelang geskied het nie.
- (f) 'n Aansoek om 'n toekenning ingevolge hierdie bepaling moet die waterreg wat die aansoeker wil aankoop, in hektaar vermeld en moet vergegaan van—
- (i) 'n nie-terugbetaalbare deposito van R1 000;
- (ii) die jongste beskikbare lugfoto('s) van die eiendom ten opsigte waarvan aansoek om 'n toekenning gedoen word, waarop getoon moet word—
- die grense van die eiendom;
- die ligging by benadering en die omvang van enige gedeelte van die eiendom wat reeds onder besproeiing is, en enige verdere gedeelte wat besproei kan word met enige balans van die maksimum inlysting ingevolge die Bepalingskennisgewing genoem in paragraaf (1), wat nog nie ten volle deur die eienaar opgeneem is nie; en
- (ii) property(ies) which he has purchased by means of a deed of sale which was concluded before the said date, but of which transfer has not yet been taken: Provided that the registration thereof in his name shall be completed on or before 31 March 1991 or on such later date as I may determine in respect of a specific case,
- and shall only be utilised to the extent to which it has been included in terms of paragraph (2) (h) hereunder in the schedule contemplated in section 64 (6) of the Water Act, 1956, in respect of the Breede River Government Water Control Area.
- (b) An allocation shall be made with due regard to the extent of irrigable land on a particular property as established by the Department of Agriculture and Water Supply or by another person or body acting at the direction of the said Department, in which case the investigation in this regard shall be conducted at the expense of the applicant and the finding by such person or body shall be subject to the approval of the said Department.
- (c) I reserve the right in any particular case, notwithstanding the availability of irrigable land as established or approved by the Department of Agriculture and Water Supply, to require of an applicant also to submit satisfactory proof that the land in question can be irrigated economically.
- (d) In the case of a property contemplated in paragraph 2 (a) (ii) the Deed of Sale shall explicitly stipulate how any existing scheduling in terms of Determination Notice 309 of 21 February 1986 in respect of the original property is allocated to the various subdivisions which will arise therefrom.
- (e) An application for an allocation shall only be considered from a person who is legally competent in respect of the property concerned, proof of which shall accompany the application: Provided that where the applicant is not the registered owner, any allocation granted in terms of this notice, shall not be included in the schedule contemplated in section 64 (6) of the Water Act in respect of the Breede River Government Water Control Area until registration of the property has taken place in the Deeds Office concerned in accordance with the established legal interest.
- (f) An application for an allocation in terms of this determination shall specify, in hectares, the water right that the applicant wishes to purchase and shall be accompanied by—
- (i) a non-refundable deposit of R1 000;
- (ii) the latest available aerial photograph(s) of the property in respect of which application for an allocation is made, on which shall be indicated—
- the boundaries of the property,
- the approximate location and extent of any portion of the property which is already under irrigation and any further portion which can be irrigated with any balance of the maximum scheduling in terms of the Determination Notice referred to in paragraph (1) which has not yet been taken up in full by the owner; and

die ligging by benadering en die omvang van die gedeelte van die eiendom wat vir besproeiing deur middel van 'n toekenning ingevolge hierdie bepaling voorgestel word; en

- (iii) 'n beëdigde opgawe wat vir die doeleindes van die toepassing van paragrawe (1) en (2) (g) alle inlysting toon ten opsigte van al die eiendomme waarvan die applikant die geregistreerde eienaar op die datum van hierdie kennisgewing is ingevolge die Bepalingskennisgewing genoem in paragraaf (1);

en moet voor 31 Maart 1988 by die kantoor van die Streekdirekteur: Wes-Kaapstreek, Privaatsak X9075, Kaapstad, 8000, ingedien word. 'n Aansoeker moet in 'n enkele aansoek doen om die totale waterreg wat hy ingevolge hierdie bepaling wil aankoop.

- (g) As vergoeding vir die opname in die betrokke lys bedoel in artikel 64 (6) van die Waterwet, van enige toekenning kragtens hierdie kennisgewing, is die volgende bedrae by wyse van kontant of 'n bankgewaarborgde tjek betaalbaar te eniger tyd voor 31 Maart 1993:

- (i) R1 370 per hektaar vir 'n oppervlakte van 1 tot 70 hektaar;
- (ii) R1 720 per hektaar vir 'n oppervlakte van 71 tot 105 hektaar;
- (iii) R2 070 per hektaar vir 'n oppervlakte van 106 tot 140 hektaar:

Met dien verstande dat by die berekening van die vergoeding wat in 'n bepaalde geval betaalbaar is—

- (aa) bogenoemde bedrae vas is tot 31 Maart 1993, maar dat saamgestelde rente vanaf 1 April 1988 gehef word teen die heersende Tesourie-rentekoers op die verskuldigde bedrag, totdat die betrokke toekenning opgeneem word deur die betaling van die verskuldigde bedrag plus enige rente; en

- (bb) enige inlysting wat ingevolge paragraaf (1) afgetrek is van die maksimum reg op bykomende inlysting wat ingevolge hierdie kennisgewing aangekoop mag word, tesame met die totale oppervlakte wat ingevolge hierdie kennisgewing verwerf staan te word, teen die glyskaal van vergoeding hierbo in berekening gebring word om te bepaal volgens watter been (bene) van die glyskaal die vergoedingsbedrag bereken moet word.

- (h) 'n Toekenning kragtens hierdie kennisgewing waarvoor of vir enige gedeelte waarvan ooreenkomstig paragraaf (2) (g) betaal is, word vanaf die datum van betaling opgeneem in die lys bedoel in artikel 64 (6) van die Waterwet, 1956, vir die betrokke Staatswaterbeheergebied en daardie inlysting is vanaf daardie datum belasbaar, tensy die betrokke eienaar die verworwe waterreg nie benut nie en ek ingevolge artikel 63 (7A) van genoemde Wet op aansoek die tydelike ontlysting van die oppervlakte wat nie besproei word nie, goedgekeur het.

- (i) Die hoeveelheid water wat jaarliks ingevolge Bepalingskennisgewing 309 van 21 Februarie 1986 ten opsigte van 'n hektaar grond binne die Breërivier-staatswaterbeheergebied voorsien kan word, geld ook vir 'n toekenning ingevolge hierdie bepaling.

the approximate location and extent of that portion of the property which is proposed for irrigation by means of an allocation in terms of this determination;

- (iii) a sworn statement reflecting, for the implementation of paragraphs (1) and (2) (g), all scheduling in respect of all the properties of which the applicant is the registered owner on the date of this notice in terms of the Determination Notice referred to in paragraph 1;

and shall be lodged at the office of the Regional Director: Western Cape Region, Private Bag X9075, Cape Town 8000, before 31 March 1988. The applicant shall apply for the entire water right that he wishes to purchase in terms of this determination in a single application.

- (g) As compensation for the inclusion in the relevant schedule contemplated in section 64 (6) of the Water Act of any allocation in terms of this notice, the following amounts shall be payable by means of cash or a bank guaranteed cheque at any time before 31 March 1993:

- (i) R1 370 per hectare for an area of 1 to 70 hectares;
- (ii) R1 720 per hectare for an area of 71 to 105 hectares; and
- (iii) R2 070 per hectare for an area of 106 to 140 hectares:

Provided that in calculating the compensation payable in a specific case—

- (aa) the above-mentioned amounts shall be fixed until 31 March 1993, but that as from 1 April 1988 compound interest at the prevailing Treasury interest rate shall be charged until the allocation concerned has been taken up by the payment of the compensation due plus any interest;

- (bb) any scheduling which has in terms of paragraph (1) been subtracted from the maximum right to additional scheduling that may be purchased in terms of this notice, together with the total area which is to be acquired in terms of this notice, shall be taken into account against the sliding scale of compensation above to determine according to which bracket(s) of the sliding scale the amount of compensation is to be calculated.

- (h) An allocation in terms of this notice in respect of which or in respect of any portion of which payment has been made in terms of paragraph 2 (g) shall be included, with effect from date of payment, in the schedule contemplated in section 64 (6) of the Water Act for the Government Water Control Area concerned and that scheduling shall be rateable as from that date, unless the owner concerned does not utilise the water right acquired and I have, on application, in terms of section 63 (7A) of the said Act, approved the temporary descheduling of the area that is not irrigated.

- (i) The quantity of water which may be supplied annually in terms of Determination Notice 309 of 21 February 1986 in respect of one hectare of land within the Breede River Government Water Control Area shall also apply to an allocation made in terms of this determination.

- (j) 'n Toekenning ingevolge hierdie bepaling word gebaseer op direkte uitneming uit die Breërivier en onthef nie die betrokke eienaar van die verpligting om die vereiste onttrekkingswerke permit of enige toepaslike serwituut te bekom nie: Met dien verstande dat dit so 'n eienaar vrystaan om in so 'n geval met 'n bevoegde instansie ooreen te kom met betrekking tot die verskaffing aan hom, deur gemeenskaplike waterwerke, van enige water waarop hy ingevolge hierdie bepaling geregtig is.
- (k) Die eienaar van 'n eiendom ten opsigte waarvan 'n toekenning ingevolge hierdie kennisgewing gemaak word, en sy opvolgers in titel, is verantwoordelik vir die instandhouding of verbetering van die produksiepotensiaal van die landbouhulpbronne wat deur die benutting van sodanige toekenning beïnvloed mag word, insluitend die daarstelling van die nodige grondbewaringswerke vir dreinerings- en vir afvoer van afloopwater, en moet die bepalings van die Wet op die Bewaring van Landbouhulpbronne, 1983 (Wet 43 van 1983), sowel as die regulasies daarkragtens nakom.
- (l) 'n Aansoeker aan wie 'n toekenning ingevolge hierdie bepaling gemaak is en wat versuim om voor 31 Maart 1993 ooreenkomstig die voorskrifte van paragraaf (g) daarvoor te betaal, verloor alle aanspraak op die toekenning of op enige gedeelte daarvan waarvoor nie ooreenkomstig genoemde paragraaf betaal is nie.

J. A. VAN WYK,
Adjunk-minister van Waterwese.

No. 2337 **16 Oktober 1987**

**BREËRIVIER - STAATSWATERBEHEERGEBIED.—
WYSIGING VAN DIE BEPALING VAN DIE MAKSIMUM
OMVANG VAN GROND WAT BESPROEI KAN
WORD**

Ek, Jacob Albertus van Wyk, Adjunk-minister van Waterwese, handelende namens die Minister van Waterwese kragtens die bevoegdheid hom verleen by artikel 63 (2) (a), saamgelees met artikel 63 (2A) van die Waterwet, 1956 (Wet 54 van 1956) wysig hierby Goewermentskennisgewing 309 van 21 Februarie 1986 deur die invoeging van die volgende paragraaf in die voorbehoudsbepaling tot paragraaf 2:

“(iv) ten opsigte van enige eiendom wat na 21 Februarie 1986 by die Staatswaterbeheergebied ingesluit word, die toekenning uit hoofde van hierdie bepaling NUL hektaar is.”

J. A. VAN WYK,
Adjunk-minister van Waterwese.

ALGEMENE KENNISGEWINGS

KENNISGEWING 726 VAN 1987

**DEPARTEMENT VAN OPENBARE WERKE EN
GRONDSAKE**

WET OP REËLING VAN GRONDTITELS, 1979

Kragtens artikel 8 van die Wet op reëling van Grondtitels, 1979 (Wet 68 van 1979), word dit bekendgemaak dat aansoekers deur persone wat daarop aanspraak maak dat hulle deur erfopvolging of andersins 'n reg verkry het om as eienaar van die grond wat in die Bylae hiervan vermeld word geregistreer te word vir twee maande vanaf 9 Oktober 1987 gedurende amptelike kantoorure by die landdroskantoor van Rustenburg ter insae sal lê.

- (j) An allocation made in terms of this determination is based on direct abstraction from the Breede River and shall not exempt the owner concerned from the obligation to obtain the required abstraction works permit or any applicable servitude: Provided that such owner shall be free in such a case to come to an agreement with a competent body regarding the supply to him, by means of joint waterworks, of water to which he is entitled in terms of this determination.
- (k) The owner of a property in respect of which an allocation is made in terms of this notice, and his successors in title, shall be responsible for the maintenance or improvement of the production potential of those agricultural resources that are influenced by the utilisation of such allocation, including the building of the necessary soil conservation works for drainage and for the disposal of run-off, and shall comply with the provisions of the Conservation of Agricultural Resources Act, 1983 (Act 43 of 1983), and the regulations promulgated in terms thereof.
- (l) An applicant to whom an allocation has been made in terms of this determination and who fails to pay therefor before 31 March 1993 in accordance with the instructions of paragraph (g) shall lose any claim to the allocation or any portion thereof for which no payment was made in accordance with the said paragraph.

J. A. VAN WYK,
Deputy Minister of Water Affairs.

No. 2337 **16 October 1987**

**BREEDERIVER GOVERNMENT WATER CONTROL
AREA.—AMENDMENT OF THE DETERMINATION
OF THE MAXIMUM EXTENT OF LAND THAT MAY
BE IRRIGATED**

I, Jacob Albertus van Wyk, Deputy Minister of Water Affairs, acting on behalf of the Minister of Water Affairs by virtue of the powers vested in him by section 63 (2) (a) read with section 63 (2A) of the Water Act, 1956 (Act 54 of 1956) hereby amend Government Notice 309 of 21 February 1986 by the insertion of the following paragraph in the proviso to paragraph 2:

“(iv) in respect of any property included in the Government water control area after 21 February 1986, the allocation in terms of this determination shall be NIL hectares.”

J. A. VAN WYK,
Deputy Minister of Water Affairs.

GENERAL NOTICES

NOTICE 726 OF 1987

**DEPARTMENT OF PUBLIC WORKS AND LAND
AFFAIRS**

LAND TITLES ADJUSTMENT ACT, 1979

In terms of section 8 of the Land Titles Adjustment Act, 1979 (Act 68 of 1979), it is made known that applications by persons who claim to have acquired a right by hereditary succession or otherwise, to be registered as an owner in respect of the land specified in the Schedule hereto, will lie for inspection during the period of two months from 9 October 1987 during the official hours of work at the Office of the Magistrate, Rustenburg.

Enigiemand wat teen die toestaan van 'n aansoek beswaar wil maak word hiermee aangesê om sy beswaar, gestaaf deur beëdigde verklarings en die stukke wat hy in staat is om voor te lê, binne 30 dae na die 9de Desember 1987 aan die Voorsitter van die Komitee, Landdroskantoor, Privaatsak X82065, Rustenburg, 0300, te verstrek.

A. N. P. ESTERHUIZEN,
Voorsitter: Rietvallei-grondverdelingskomitee: Swart-ruggens.

BYLAE

1. Gedeelte 4 van die plaas Rietvallei 406, Registrasieafdeling JP, Transvaal, groot 5,7481 hektaar.
2. Gedeelte 8 van dieselfde plaas, groot 6,5066 hektaar.
3. Restant van Gedeelte 2 van dieselfde plaas, groot 1 083,9027 hektaar.
4. Gedeelte 18 ('n gedeelte van Gedeelte 2) van dieselfde plaas, groot 5,3376 hektaar.
5. Gedeelte 32 ('n gedeelte van Gedeelte 2) van dieselfde plaas, groot 1,7202 hektaar.

(16 Oktober 1987)

Any person who wishes to object to the granting of any application is called upon to furnish his objection and the grounds therefor, supported by sworn declarations and such documents as he may be able to submit, in writing to the Chairman of the Committee, Magistrate's Office, Private Bag X82065, Rustenburg, 0300 within a period of 30 days after 9th December 1987.

A. N. P. ESTERHUIZEN,
Chairman: Rietvallei Land Division Committee: Swart-ruggens.

SCHEDULE

1. Portion 4 of the farm Rietvallei 406, Registration Division JP, Transvaal, in extent 5,7481 hectares.
2. Portion 8 of the same farm, in extent 6,5066 hectares.
3. Remainder of Portion 2 of the same farm, in extent 1 083,8027 hectares.
4. Portion 18 (a portion of Portion 2) of the same farm, in extent 5,3376 hectares.
5. Portion 32 (a portion of Portion 2) of the same farm, in extent 1,7202 hectares.

(16 October 1987)

KENNISGEWING 756 VAN 1987—NOTICE 756 OF 1987

WET OP VEEBRANDMERKE, 1962 (WET 87 VAN 1962)
LIVESTOCK BRANDS ACT, 1962 (ACT 87 OF 1962)

KWARTAALLIKSE OPGAWE VAN BRANDMERKE GEREGISTREER VANAF 1 JULIE 1987 TOT 30 SEPTEMBER 1987
QUARTERLY REPORT OF BRANDS REGISTERED FROM 1 JULY 1987 TOT 30 SEPTEMBER 1987

Brandmerk Brand	Naam van eienaar Name of owner	Adres Address
MAE	Roos, J. P. B.	Skutmeester, Posbus 79, Pongola, 3170.
MAF	Van Niekerk, J. W.	Posbus 388, Amersfoort, 2490.
MAG	Masina, M. A.	Private Bag X1005, Mogwase, 0302.
MAH	Mokgongwana, S. D.	Private Bag X1007, Madikwe, 2835.
MAI	Molaodi, T. A.	P.O. Box 297, Swartklip, 0370.
MAJ	Bosch, J. M.	Posbus 10, Vereeniging, 1930.
MAK	Botha, T. B.	Corrystraat 206, Queenswood, 0186.
MAL	Mbonane, J. M.	Posbus 165, Ekangala, 1021.
MAm	Moyaha, M. S.	Private Bag X231, Bochum, 0290.
MAN	H & V Boerdery BK.....	Posbus 1746, Vryburg, 8600.
MAO	Loabile, M. O.	Private Bag X508, Ganyesa, 8613.
MAP	Segakwaneng, M. P.	Private Bag X1005, Mogwase, 0302.
MAQ	Mokoto, N. J.	Private Bag X2138, Mmabatho, 8681.
MAR	Jansen van Rensburg, D. J. G.	Spencerlaan 39, Orkney, 2620.
MAS	Strooh, E.	Posbus 15, Karino, 1204.
MAT	Ntebele, S. S.	Posbus 6292, Ellisras, 0555.
MAU	Sibanda, J. M.	Posbus 6292, Ellisras, 0555.
MAV	Martins, D. F.	Private Bag X1007, Madikwe, 2835.
MAW	Ditau, S. C.	Private Bag X1005, Mogwase, 0302.
MAX	Pilane, D. G.	Private Bag X1005, Mogwase, 0302.
MAy	Nkau, G. M.	P.O. Box 3086, Mmabatho, 8681.
MAZ	Motsuenyane, J. S.	P.O. Box 475, Delareyville, 2770.
MBA	Ngubane, N. P.	Mazwendoda High School, Impendle, 4545.
MBB	Böhme, G. N. O.	P.O. Box 523, Schweizer-Reneke, 2780.
MBC	Leemtrust (Edms.) Bpk.	Posbus 113, Ogies, 2230.
MBD	Sibi, J. M.	Private Bag B999, Vryburg, 8600.
MBE	Grobler, I.S. (mev.)	Posbus 6607, Onverwacht, 0557.
MBF	Burger, W. J. P.	Posbus 166, Koster, 2825.
MBG	Elesang, K. G.	Private Bag X508, Ganyesa, 8613.
MBH	Tshesebe, R. P.	Private Bag X2, Vryburg, 8600.
MBI	Shashape, D. M.	Private Bag X508, Ganyesa, 8613.
MBJ	Molefe, N. D.	Private Bag X92105, Phokeng, 0316.
MBK	Nkosi, P. M.	Private Bag X1005, Mogwase, 0302.
MBL	Letlape, M. S.	Private Bag X1005, Mogwase, 0302.
MBM	Mokoka, P. M.	Private Bag X1005, Mogwase, 0302.
MBN	Sebokwane, M. N.	Private Bag X1005, Mogwase, 0302.
MBO	Grobler, D. H.	Posbus 278, Dendron, 0715.
MBP	Lehutso, P. P.	Private Bag X498, Hammanskraal, 0400.
MBQ	Penta Boerdery Trust	Posbus 577, Bethal, 2310.
MBR	Masikane, R. N.	Private Bag X92105, Phokeng, 0316.

Brandmerk Brand	Naam van eienaar Name of owner	Adres Address
m BS	Kole, M. J.	Private Bag X92105, Phokeng, 0316.
m BT	Mogakabe, S.	Private Bag X92105, Phokeng, 0316.
m BU	Kgomo, S. J.	Private Bag X498, Hammanskraal, 0400.
m BV	Rakoma, R. P.	Private Bag X1005, Mogwase, 0302.
m BW	Hlongwani, K. J.	P.O. Box 662, Ellisras, 0555.
m BX	Phukubje, R. L.	Private Bag X2700, Potgietersrus, 0600.
m BY	Hertzog, J. B. M.	Posbus 34, Balmoral, 1037.
m BZ	Madonsela, Z. K.	Obonjaneni L.P. School, P.O. Mont-Aux-Sources, 3353.
m CA	Mokoane, P. A.	Private Bag X1005, Mogwase, 0302.
m CB	Bester, J. J.	Posbus 2982, Pietersburg, 0700.
m CC	Khunou, O. M.	Bafokeng Magistrate Offices, Private Bag X92098, Phokeng, 0316.
m CD	Meiring, S.	Posbus 203, Bethal, 2310.
m CE	Elreco Beleggings	Posbus 100, Val, 2425.
m CF	Lephogole, M. F.	Private Bag X1005, Mogwase, 0302.
m CG	Mogotsi, M. G.	Private Bag X2112, Mafikeng, 8670.
m CH	Mookwe, K. C.	Private Bag X2, Vryburg, 8600.
m CI	Kujane, M. J.	P.O. Box 614, Taung Station, 8580.
m CJ	Mocwiri, J. W.	Private Bag X1007, Madikwe, 2835.
m CK	Mokhutswane, C. D.	P.O. Box 378, Jericho, 0264.
m CL	Mophahlane, T. T.	Fafung, Bultfontein, 9670.
m CM	Jiyane, T. A.	P.O. Box 67, Kwa Mazitapele, Nqutu, 3135.
m CN	Matjila, M. P.	P.O. Box 718, Hammanskraal, 0400.
m CO	Boffa, R.	Posbus 193, Elliot, 5460.
m CP	Mokgalutsi, N. P.	Private Bag X231, Bochum, 2790.
m CQ	Keebine, T. E.	Private Bag X2008, Lerato, 2865.
m CR	Roos, M. H.	Afswaai, Enzelsberg, Zeerust, 2865.
m CS	Mosesi, S. W.	Private Bag X1005, Mogwase, 0302.
m CT	Makhuba, T. A.	Private Bag X1005, Mogwase, 0302.
m CU	Rapholo, T. L.	Private Bag X498, Hammanskraal, 0400.
m CV	Visser, G. J. J. & A. P.	Posbus 41, Barberspan, 2765.
m CW	Van Vuuren, M. M. J.	Posbus 423, Vryburg, 8600.
m CX	Myburgh, J. J. B.	Posbus 1585, Ermelo, 2350.
m CY	Molhaga, R. E.	Private Bag X1005, Mogwase, 0302.
m CZ	Mmoloke, M. G.	Private Bag X2008, Lerato, 2865.
m DA	Majadibodu, J. T.	Private Bag X2654, Potgietersrus, 0600.
m DB	Kgomo, F.	Private Bag X498, Hammanskraal, 0400.
m DC	Scheepers, L. S. (mev.)	Posbus 470, Zeerust, 2865.
m DD	Uys, M. J.	Posbus 292, Koster, 2825.
m DE	Human, J. L.	Ben Viljoenstraat 363, Pretoria-Noord, 0182.
m DF	Hamman, G. F.	Chroomstraat 8, Potgietersrus, 0600.
m DG	Vilonel, F. P. J.	Posbus 247, Glenvista, 2058.
m DH	Le Roux, G. H.	Posbus 218, Schweizer-Reneke, 2780.
m DI	Makoka, I. M. T.	Private Bag X1007, Madikwe, 2835.
m DJ	Pistorius, T. G. J.	Posbus 25, Phalaborwa, 1390.
m DK	Seape, C. M. K.	P.O. Box 61, Thaba Nchu, 9780.
m DL	Lombard, L. J. C.	Posbus 208, Vaalwater, 0530.
m DM	Nkomane, M. D.	Private Bag X1005, Mogwase, 0302.
m DN	Davies, A. M.	P.O. Box 716, Queenstown, 5320.
m DO	Kaekae, K. E.	Private Bag X061, Sesheng, 8447.
m DP	Geyser, J.	Posbus 130, Ermelo, 2350.
m DQ	Odendaal, K. P.	Posbus 409, Queenstown, 5320.
m DR	Swart, A. P.	Vyfde Straat 53a, Lichtenburg, 2740.
m DS	Senoamadi, M. S.	Private Bag X2618, Potgietersrus, 0600.
m DT	Madonda, M. Z.	P.O. Box 4, Impendle, 4545.
m DU	Visser, J. A.	Posbus 12, Barberspan, 2765.
m DV	Visser, E. J. J.	Posbus 154, Messina, 0900.
m DW	Mangope, T. T.	Private Bag X1005, Mogwase, 0302.
m DX	Erasmus, B. D. T.	Posbus 129, Hendrina, 1095.
m DY	Magape, S.	Driehoek, P.O. Driehoek, 2746.
m DZ	Breetzke, V. O.	P.O. Box 487, Queenstown, 5320.
m EA	Roeloffze, A. A.	Posbus 218, Schweizer-Reneke, 2780.
m EB	Gumbi, T. W.	Silutshana G.P. School, P.O. Silutshana, 3011.
m EC	Phillips, C. J.	Elandskraal, Tarkastad, 5370.
m ED	Du Plessis, N. J.	Posbus 54, Pk. Chrissiesmeer, 2332.
m EE	McEwan, M. G.	P.O. Box 58, Tarkastad, 5370.
m EF	Porter, A. R.	P.O. Box 11, Tarkastad, 5370.

BRANDMERKE GEROJEEER/BRANDS CANCELLED

Brandmerk Brand	Naam van gewese eienaar Name of previous owner	Adres van gewese eienaar Address of previous owner	Datum van rojering Date of cancellation	Opmerkings Remarks
o AF	Pienaar, A. J. G.	Posbus 4, Northam, 0360	1987-04-13	Opheffing van skut.

(16 Oktober 1987)/(16 October 1987)

KENNISGEWING 757 VAN 1987

DEPARTEMENT VAN MINERAAL- EN ENERGIESAKE

UITHOU VAN GROND VIR DIE DOELEINDES VAN 'N OPENBARE PAD

Die Mynkommissaris vir die myndistrik Johannesburg het 'n strook geproklameerde grond op die plaas Waterval 174 IQ, distrik Krugersdorp, myndistrik Johannesburg, provinsie Transvaal, soos getoon op 'n sketskaart waarvan af-drukke onder R.M.T. R79/87 in die Mynbriewekantoor, Johannesburg, en in die kantoor van die Mynkommissaris, Johannesburg bewaar word, kragtens artikel 179 (1) (b) van die Wet op Mynregte, 1967 (Wet 20 van 1967), vir die doeleindes van 'n openbare pad uitgehou.

(16 Oktober 1987)

NOTICE 757 OF 1987

DEPARTMENT OF MINERAL AND ENERGY AFFAIRS

RESERVATION FOR LAND FOR THE PURPOSES OF A PUBLIC ROAD

The Mining Commissioner for the Mining District of Johannesburg has, in terms of section 179 (1) (b) of the Mining Rights Act, 1967 (Act 20 of 1967), reserved for the purposes of a public road a strip of proclaimed land on the farm Waterval 174 IQ, District of Krugersdorp, Mining District of Johannesburg, Province of the Transvaal, as shown on a sketch plan, copies of which have been filed under R.M.T. R79/87 in the Mining Titles Office, Johannesburg, and in the office of the Mining Commissioner, Johannesburg.

(16 October 1987)

KENNISGEWING 759 VAN 1987

ADMINISTRASIE: VOLKSRAAD

DEPARTEMENT VAN LANDBOU EN WATERVOORSIENING

KENNISGEWING VAN VERGADERING VAN SKULDEISERS KRAGTENS ARTIKEL 22 (1) VAN DIE WET OP LANDBOUKREDIET, 1966

Hierby word 'n vergadering van ondergenoemde applikant en sy skuldeisers op die plek en datum hieronder genoem, belê, met die doel om skuldeisers in staat te stel om hul vorderings teen die applikant te bewys en 'n skikkingsvoorstel van die Landboukredietraad te oorweeg.

J. H. RADEMEYER,

Direkteur: Direktoraat Finansiële Bystand,
Departement van Landbou en Watervoorsiening.

NOTICE 759 OF 1987

ADMINISTRATION: HOUSE OF ASSEMBLY

DEPARTMENT OF AGRICULTURE AND WATER SUPPLY

NOTICE OF MEETING OF CREDITORS IN TERMS OF SECTION 22 (1) OF THE AGRICULTURAL CREDIT ACT, 1966

Meeting of the undermentioned applicant and his creditors is hereby convened at the place and date mentioned hereunder for the purpose of enabling creditors to prove their claims against the applicant and of considering a proposal for compromise by the Agricultural Credit Board.

J. H. RADEMEYER,

Director: Directorate Financial Assistance,
Department of Agriculture and Water Supply.

Aansoek van/Application by	Plek van byeenkoms/Place of meeting	Datum en tyd/Date and time
Johannes Albertus Badenhorst en J. A. Badenhorst Boerdery (Edms.) Bpk., Posbus 24, Gerdau, 2729.	Kantoor van die Landdros/The Magistrate's Office, Coligny	9 Desember/December 1987 om/at 10h00.

(16 Oktober 1987/16 October 1987)

KENNISGEWING 760 VAN 1987

DEPARTEMENT VAN WATERWESE

BENEDE-SONDAGSRIVIER - STAATSWATERBEHEERGEBIED, DISTRIKTE JANSENVILLE, KIRKWOOD, PORT ELIZABETH EN SOMERSET-OOS.—INLYSTINGSVERGADERING

Hierby word ingevolge artikel 64 van die Waterwet, 1956, bekend gemaak dat sittings van die Inlystingsraad in verband met die lys van belasbare oppervlaktes van die Benede-Sondagsrivier-staatswaterbeheergebied op die plek en tyd hieronder genoem gehou sal word met die doel om aansprake op opneming in genoemde lys of besware teen enige van die name, eiendomme of oppervlaktes wat daarin voorkom, aan te hoor en daaroor te besluit:

- (a) Om 09h00 op Dinsdag en Woensdag 3 en 4 November 1987 in die Sondagsrivier-besproeiingsraadsaal, Belmontweg, Sunland.

NOTICE 760 OF 1987

DEPARTMENT OF WATER AFFAIRS

LOWER SUNDAYS RIVER GOVERNMENT WATER CONTROL AREA, DISTRICTS OF JANSENVILLE, KIRKWOOD, PORT ELIZABETH AND SOMERSET EAST.—SCHEDULING BOARD MEETING

It is hereby notified in terms of section 64 of the Water Act, 1956, that meetings of the Scheduling Board in connection with the schedule of rateable areas of Lower Sunday River Water Control Area will be held at the times and place mentioned below for the purpose of hearing and determining claims for inclusion in the said schedule or objects to any of the names, properties or areas included therein:

- (a) At 09h00 on Tuesday and Wednesday 3 and 4 November 1987 in the Sunday River Irrigation Board Hall, Belmont Road, Sunland.

Afskrifte van die lys van belasbare oppervlaktes, wat ingevolge artikel 63 (7) van die genoemde Wet opgestel is, sal vanaf Maandag 19 Oktober 1987 by die volgende plekke ter insae lê:

- (a) Kantoor van die Sondagsrivierbesproeiingsraad, Sunland.
- (b) Landdroeskantoor, Kirkwood.
- (c) Poskantoor, Addo.

Enige geregistreerde eienaar van grond in bogenoemde gebied wat nie genoemde vergadering kan bywoon nie, kan enige ander persoon skriftelik magtig om hom/haar op die vergadering te verteenwoordig.

(16 Oktober 1987)

Copies of the schedule of rateables areas, prepared in terms of section 63 (7) of the said Act, will be lying for inspection at the following places from Monday 19 October 1987.

- (a) Office of the Sundays River Irrigation Board, Sunland.
- (b) Magistrate's office, Kirkwood.
- (c) Post Office, Addo.

Any registered owner of land in the said area who is unable to attend the said meeting, may authorise any other person, in writing, to represent him/her at the meeting.

(16 October 1987)

KENNISGEWING 761 VAN 1987

DEPARTEMENT VAN MANNEKRAG

WET OP ARBEIDSVERHOUDINGE, 1956

AANSOEK OM VERANDERING VAN DIE REGISTRASIEBESTEK VAN 'N VAKVERENIGING

Ek, Gerrit Petrus van den Berg, Assistent-nywerheids-registrateur, maak ingevolge artikel 4 (2) soos toegepas by artikel 7 (5) van die Wet op Arbeidsverhoudinge, 1956, hierby bekend dat 'n aansoek om die verandering van sy registrasiebestek ontvang is van die Laundry, Dry-cleaning and Dyeing Employees' Union (Natal). Besonderhede van die aansoek word in onderstaande tabel verstrek.

Enige geregistreerde vakvereniging wat teen die aansoek beswaar maak, word versoek om binne een maand na die datum van publikasie van hierdie kennisgewing sy beswaar skriftelik by my in te dien, p/a die Departement van Mannekrag, Mannekraggebou 449, Schoemanstraat 215, Pretoria (posadres: Privaatsak X117, Pretoria, 0001).

TABEL

Naam van vakvereniging: Laundry, Dry-cleaning and Dyeing Employees' Union (Natal).

Datum waarop aansoek ingedien is: 28 Augustus 1987.

Belange en gebied ten opsigte waarvan aansoek gedoen word: Alle persone in diens in die Wassery-, Droogskoonmaak- en Kleurbedryf in die landdroosdistrikte Chatsworth, Durban, Inanda (uitgesonderd die gedeeltes wat binne die selfregerende gebied kwaZulu val) en Pinetown.

Vir die doel hiervan beteken "Wassery-, Droogskoonmaak- en Kleurbedryf" die bedryf waarin werkgewers en werknemers met mekaar geassosieer is met die doel om werksaamhede te verrig in verband met die was, droogskoonmaak, kleur, bleik of behandeling van artikels, en omvat dit linneverhuurdienste met 'n winsmotief, ontvangsdepots, voertuie en bedryfsinrigtings waarin muntoutomate of enige ander selfbedienings- of outomatiese wasmasjiene en droogskoonmaakmasjiene beskikbaar is vir gebruik deur klante.

Belange en gebiede ten opsigte waarvan registrasie gehou word: Alle persone wat in die Wassery-, Droogskoonmaak- en Kleurbedryf in diens is van die landdroosdistrikte Durban, Inanda en Pinetown, soos die gebiede saamgestel was op 20 Oktober 1982.

"Wassery-, Droogskoonmaak- en Kleurbedryf" beteken die bedryf waarin werkgewers en werknemers met mekaar geassosieer is met die doel om werksaamhede te verrig in verband met die was en stryk, droogskoonmaak, kleur, bleik of behandelingsberoep, en dit omvat ontvangsdepots, voertuie en 'n bedryfsinrigting waarin muntoutomate of enige selfbedien- of outomatiese was- en droogskoonmaakmasjiene vir gebruik van klante beskikbaar gestel word.

NOTICE 761 OF 1987

DEPARTMENT OF MANPOWER

LABOUR RELATIONS ACT, 1956

APPLICATION FOR VARIATION OF SCOPE OF REGISTRATION OF A TRADE UNION

I, Gerrit Petrus van den Berg, Assistant Industrial Registrar, do hereby, in terms of section 4 (2) as applied by section 7 (5) of the Labour Relations Act, 1956, give notice that an application for the variation of its scope of registration has been received from the Laundry, Dry-cleaning and Dyeing Employees' Union (Natal). Particulars of the application are reflected in the subjoined table.

Any registered trade union which objects to the application is invited to lodge its objection in writing with me, c/o the Department of Manpower, 449 Manpower Building, 215 Schoeman Street, Pretoria (postal address: Private Bag X117, Pretoria, 0001), within one month of the date of publication of this notice.

TABLE

Name of trade union: Laundry, Dry-cleaning and Dyeing Employees' Union (Natal).

Date on which application was lodged: 28 August 1987.

Interests and area in respect of which application is made: All persons who are employed in the Laundry, Dry-cleaning and Dyeing Industry in the Magisterial Districts of Chatsworth Durban, Inanda (excluding those areas falling within the self-governing territory of kwaZulu) and Pinetown.

For the purpose hereof "Laundry, Dry-cleaning and Dyeing Industry" means the industry in which employers and employees are associated for the purpose of carrying on activities involved in the laundering, dry-cleaning, dyeing, bleaching or processing of articles, and includes linen-hire services for gain, receiving depots, vehicles and establishments in which coin operated machines or any other self-operated or automatic washing and dry-cleaning machines are available for use by customers.

Interests and areas in respect of which registration is held: All persons who are employed in the Laundry, Dry Cleaning and Dyeing Industry in the Magisterial Districts of Durban, Inanda and Pinetown, as these areas were constituted as at 20 October 1982.

"Laundry, Dry Cleaning and Dyeing Industry" means the Industry in which employers and employees are associated for the purpose of carrying on activities involved in the laundering, dry cleaning, dyeing, bleaching or processing occupations and includes receiving depots, vehicles and and establishment in which coin operated machines or any self operated or automatic washing and dry cleaning machines are made available for use by customers.

Posadres van applikant: Posbus 3069, Durban, 4000.

Kantooradres van applikant: Valbro Kamers 33, Victoriastraat 115a, Durban.

Die aandag word gevestig op onderstaande vereistes van artikels 4 en 7 van die Wet:

- (a) Die mate waarin 'n beswaarmakende vakvereniging verteenwoordigend is, word ingevolge artikel 4 (4) soos toegepas by artikel 7 (5), bepaal volgens die feite soos hulle bestaan het op die datum waarop die aansoek ingedien is, en wat die lidmaatskap betref, word alleen lede wat ingevolge artikel 1 (2) van die Wet op voormelde datum volwaardige lede was, in aanmerking geneem.
- (b) Die prosedure voorgeskryf by artikel 4 (2) moet gevolg word in verband met 'n beswaar wat ingedien word.

G. P. VAN DEN BERG,
ASSISTENT-NYWERHEIDSREGISTRATEUR.
(16 Oktober 1987)

KENNISGEWING 762 VAN 1987

DOEANE- EN AKSYNSTARIEFAANSOEKE.—LYS
33/87

Onderstaande aansoeke betreffende die Doeane- en Aksynstarief is deur die Raad van Handel en Nywerheid ontvang. Enige beswaar teen of kommentaar op hierdie vertoë moet binne ses weke na die datum van hierdie kennisgewing aan die Raad van Handel en Nywerheid, Privaatsak X753, Pretoria, 0001, gerig word.

Verhoging van die reg op:

1. (a) Tweewielfietse, met 'n waarde vir belastingdoeleindes van hoogstens R30 elk, indeelbaar by tariefsubpos 87.10.10.03, van 20 per cent *ad valorem* tot 30 per cent *ad valorem*;
- (b) tweewielfietse, met 'n waarde vir belastingdoeleindes van meer as R30 elk, indeelbaar by tariefsubpos 87.10.10.07, van 20 per cent *ad valorem* of 7 000c elk min 80 per cent *ad valorem* tot 30 per cent *ad valorem* of 12 000c elk min 70 per cent *ad valorem*.

[RHN-verw. T5/2/17/3/1(B47/87)]

Applikant:

Raleigh Cycles (South Africa) Ltd, Posbus 581, Springs, 1560.

2. (a) Tweewielfietse, met 'n waarde vir belastingdoeleindes van hoogstens R30 elk, indeelbaar by tariefsubpos 87.10.10.03, van 20 per cent *ad valorem* tot 30 per cent *ad valorem*;
- (b) tweewielfietse, indeelbaar by tariefsubpos 87.10.10.07, van 20 per cent *ad valorem* of 7 000c elk min 80 per cent *ad valorem*, synde:
 - (i) met 'n waarde vir belastingdoeleindes van meer as R30 elk maar hoogstens R120 elk tot 30 per cent *ad valorem* of 12 000c elk min 70 per cent *ad valorem*; en
 - (ii) tweewielfietse met 'n waarde vir belastingdoeleindes van meer as R120 elk, tot 30 per cent *ad valorem*.

[RHN-verw. T5/2/17/3/1(B49/87)]

Applikant:

Western Flyer Manufacturing (Pty) Ltd, Posbus 362, King William's Town, 5600.

Postal address of applicant: P.O. Box 3069, Durban, 4000.

Office address of applicant: 33 Valbro Chambers, 115a Victoria Street, Durban.

Attention is drawn to the following requirements of sections 4 and 7 of the Act:

- (a) The representativeness of any trade union which objects to the application shall in terms of section 4 (4) as applied by section 7 (5) be determined on the facts as they existed at the date on which the application was lodged and, as far as membership is concerned, only members who were in good standing in terms of section 1 (2) of the Act as the aforesaid date shall be taken into consideration.
- (b) The procedure laid down in section 4 (2) must be followed in connection with any objection lodged.

G. P. VAN DEN BERG,
ASSISTANT-INDUSTRIAL REGISTRAR.
(16 October 1987)

NOTICE 762 OF 1987

CUSTOMS AND EXCISE TARIFF APPLICATIONS.—
LIST 33/87

The following applications concerning the Customs and Excise Tariff have been received by the Board of Trade and Industry. Any objections must be submitted to the Board of Trade and Industry, Private Bag X753, Pretoria, 0001, within six weeks of the date of this notice.

Increase in the duty on:

1. (a) Bicycles, of a value for duty purposes not exceeding R30 each, classifiable under tariff subheading 87.10.10.03, from 20 per cent *ad valorem* to 30 per cent *ad valorem*;
- (b) bicycles, of a value for duty purposes exceeding R30 each, classifiable under tariff subheading 87.10.10.07, from 20 per cent *ad valorem* or 7 000c each less 80 per cent *ad valorem* to 30 per cent *ad valorem* or 12 000c each less 70 per cent *ad valorem*.

[BTI Ref. T5/2/17/3/1(B47/87)]

Applicant:

Raleigh Cycles (South Africa) Ltd, P.O. Box 581, Springs, 1560.

2. (a) Bicycles, of a value for duty purposes not exceeding R30 each, classifiable under tariff subheading 87.10.10.03, from 20 per cent *ad valorem* to 30 per cent *ad valorem*;
- (b) bicycles, classifiable under tariff subheading 87.10.10.07 from 20 per cent *ad valorem* or 7 000c each less 80 per cent *ad valorem*, being:
 - (i) bicycles of a value for duty purposes exceeding R30 each but not exceeding R120 each, to 30 per cent *ad valorem* or 12 000c each less 70 per cent *ad valorem*; and
 - (ii) bicycles of a value for duty purposes exceeding R120 each, to 30 per cent *ad valorem*.

[BTI Ref. T5/2/17/3/1(B49/87)]

Applicant:

Western Flyer Manufacturing (Pty) Ltd, P.O. Box 362, King William's Town, 5600.

3. (a) Sokkies, met 'n voetlengte van hoogstens 160 mm of 110 mm ten opsigte van rektipe sokkies, indeelbaar by tariefsubpos 60.03.50.20, van 25 persent *ad valorem* of 5c per paar tot 25 persent *ad valorem* of 120c per paar min 75 persent *ad valorem*; en
- (b) ander sokkies, indeelbaar by tariefsubpos 60.03.50.90, van 25 persent *ad valorem* of 65c per paar min 75 persent *ad valorem* tot 25 persent *ad valorem* of 200c per paar min 75 persent *ad valorem*.

[RHN-verw. T5/2/11/8/1(B58/87)]

Applikant:

Maxmore Knitting Mills (Pty) Ltd, Boforsirkeel 104, Epping Industria 4, Kaap, 7460.

Korting van die reg (in Bylae 3) op:

1. Alkielbenseensulfoonsuur, indeelbaar by tariefsubpos 29.30.50, vir die vervaardiging van bereide addisie-stowwe vir swaar smeerolies.

[RHN-verw. T5/2/6/2/1(D97/87)]

Applikant:

Chemical Resources (Edms.) Bpk., Privaatsak X2, Modderfontein, 1645.

(Opmerking: Hierdie aansoek vervang die aansoek wat in Lys 31/87 by Algemene Kennisgewing 707 in *Staatskoerant* 10957 van 2 Oktober 1987 gepubliseer is.)

(Opmerking: Hierdie aansoek word as dringend behandel en kommentaar moet die Raad binne vier weke na die datum van hierdie kennisgewing bereik.)

2. Wasse met hars vermeng, indeelbaar by tariefpos 34.04, vir die vervaardiging van gietstukke.

[RHN-verw. T5/2/15/2/1(D98/87)]

Applikant:

CEG Foundries Company, Posbus 751, Springs, 1560.

3. Garing van poliëstervesels, ongekleur, indeelbaar by tariefsubpos 56.05.25, vir die vervaardiging van gekleurde naaigaring.

[RHN-verw. T5/2/11/9/1(D101/87)]

Applikant:

Inflation Fighters, Posbus 1869, Kaapstad, 8000.

(Opmerking: Hierdie aansoek word as dringend behandel en kommentaar moet die Raad binne vier weke na die datum van hierdie kennisgewing bereik.)

4. Magnetiese band met 'n breedte van hoogstens 6,3 mm vir klankopnames nie in kassette bemark nie, indeelbaar by tariefsubpos 92.12.40.15, vir die vervaardiging van magnetiese klankopnames in kassette bemark.

[RHN-verw. T5/2/18/4/1(C39/87)]

Applikant:

EMI South Africa (Pty) Ltd, Posbus 11254, Johannesburg, 2000.

Algemeen:

Vervanging van die huidige voorsienings by tariefsubposte 85.19.50.25 en 85.19.50.27 deur die volgende:

- 85.19.50.23 Stroombrekers en afsonderskakelaars, met gevormde 25%
omhulsels van kunplastiekstof, met 'n stroomdraver-
moë van hoogstens 1 250 A, vir spannings van
hoogstens 1 100 V (ws.) of 125 V per pool (gs.) en 'n
breekvermoëaanslag van hoogstens 100 000 A.

3. (a) Socks, with a foot length not exceeding 160 mm or 110 mm in respect of stretch type socks, classifiable under tariff subheading 60.03.50.20, from 25 per cent *ad valorem* or 5c per pair to 25 per cent *ad valorem* or 120c per pair less 75 per cent *ad valorem*; and

- (b) other socks, classifiable under tariff subheading 60.03.50.90, from 25 per cent *ad valorem* or 65c per pair less 75c *ad valorem* to 25 per cent *ad valorem* or 200c per pair less 75 per cent *ad valorem*.

[BTI Ref. T5/2/11/8/1 (B58/87)]

Applicant:

Maxmore Knitting Mills (Pty) Ltd, 104 Bofors Circle, Epping Industria 4, 7460.

Rebate of the duty (in Schedule 3) on:

1. Alkyl benzene sulphonic acids, classifiable under tariff subheading 29.03.50, for the manufacture of prepared additives for heavy lubricating oil.

[BTI Ref. T5/2/6/2/1(D97/87)]

Applicant:

Chemical Resources (Pty) Ltd, Private Bag X2, Modderfontein, 1645.

(Note: This application supersedes the application published in List 31/87 under General Notice 707 in *Government Gazette* 10957 of 2 October 1987.)

(Note: This application is being dealt with as a matter of urgency and comments should reach the Board within four weeks of the date of this notice.)

2. Waxes mixed with resin, classifiable under tariff heading 34.04, for the manufacture of castings.

[BTI Ref. T5/2/15/2/1(D98/87)]

Applicant:

CEG Foundries Company, P.O. Box 751, Springs, 1560.

3. Yarn of polyester fibres, not dyed, classifiable under tariff subheading 56.05.25, for the manufacture of dyed sewing yarn.

[BTI Ref. T5/2/11/9/1(D101/87)]

Applicant:

Inflation Fighters, P.O. Box 1869, Cape Town, 8000.

(Note: This application is being dealt with as a matter of urgency and comments should reach the Board within four weeks of the date of this notice.)

4. Magnetic tape with a width not exceeding 6,3 mm for sound recordings not put up in cassettes, classifiable under tariff subheading 92.12.40.15, for the manufacture of recorded magnetic tape put up in cassettes.

[BTI Ref. T5/2/18/4/1(C39/87)]

Applicant:

EMI South Africa (Pty) Ltd, P.O. Box 11254, Johannesburg, 2000.

General:

Substitution for the existing provision under tariff subheadings 85.19.50.25 and 85.19.50.27 of the following:

- 85.19.50.23 Circuit breakers and isolating switches, with moulded 25%
casings of artificial plastic material with a current rat-
ing not exceeding 1 250 A, for voltages not exceeding
1 100 V (a.c.) or 125 V per pole (d.c.) and a breaking
capacity rating not exceeding 100 000 A.

(Opmerking: Hierdie aansoek vervang die aansoek afgekondig by Algemene Kennisgewing 372 in Staatskoerant 10758 van 5 Junie 1987.)

(Opmerking: Hierdie aansoek word as dringend behandel en kommentaar moet die Raad binne vier weke na die datum van die kennisgewing bereik.)

[RHN-verw. T5/2/16/3/1(F47/87)]

Applikant:

Heinemann Electric (SA) Ltd, Posbus 881, Johannesburg, 2000.

Lys 32/87 is by Algemene Kennisgewing 742 van 9 Oktober 1987 gepubliseer.
(16 Oktober 1987).

(Note: This application supersedes the application published under General Notice 372 in Government Gazette 10758 of 5 June 1987.)

(Note: This application is being dealt with as a matter of urgency and comments should reach the Board within four weeks of the date of this notice.)

[BTI Ref. T5/2/16/3/1(F47/87)]

Applicant:

Heinemann Electric (SA) Ltd, P.O. Box 881, Johannesburg, 2000.

List 32/87 was published under General Notice 742 of 9 October 1987.
(16 October 1987)

KENNISGEWING 763 VAN 1987

DEPARTEMENT VAN WATERWESE

KROKODILRIVIER(WES - TRANSVAAL) - STAATSWATERBEHEERGEBIED.—INLYSTINGSRAADVERGADERING

Hierby word ingevolge artikel 64 van die Waterwet, 1956, bekendgemaak dat 'n sitting van die Inlystingsraad in verband met die lys van belasbare oppervlaktes van die Krokodilrivier(Wes - Transvaal) - staatswaterbeheergebied om 10h00 op Vrydag 30 Oktober 1987 in die kantoor van die Departement van Waterwese te Koedoeskop gehou sal word met die doel om aansprake op opneming in genoemde lys of besware teen enige van die name, eiendomme of oppervlaktes wat daarin voorkom, aan te hoor en daaroor te besluit.

Afskrifte van die lys van belasbare oppervlaktes, wat ingevolge artikel 63 (7) van genoemde Wet opgestel is, sal van Vrydag 16 Oktober 1987 by die volgende plekke ter insae lê:

- (a) Kantoor van die Departement van Waterwese te Koedoeskop.
- (b) Polisiestasie Assen.
- (c) Poskantoor Beestekraal.
- (d) Poskantoor Koedoeskop.

Enige geregistreerde eienaar van grond in genoemde gebied wat nie genoemde vergadering kan bywoon nie, kan enige ander persoon skriftelik magtig om hom/haar op die vergadering te verteenwoordig.

(16 Oktober 1987)

RAADSKENNISGEWING

RAADSKENNISGEWING 63 VAN 1987

DIE SUID-AFRIKAANSE RAAD OP VERPLEGING

AANWYSING VAN 'N LID VAN DIE RAAD VIR DIE TYDPERK WAT OP 31 MAART 1989 TEN EINDE LOOP

Ingevolge artikel 5 (6) van die Wet op Verpleging, Wet 50 van 1978, word kennis gegee van die aanwysing van Dr. D. J. Jacobs as lid van die Raad ingevolge artikels 5 (1) (f) en 6 (2) van die Wet met ingang vanaf 14 September 1987, in die plek van mnr. H. J. Joubert.

(16 Oktober 1987)

NOTICE 763 OF 1987

DEPARTMENT OF WATER AFFAIRS

CROCODILE RIVER (WESTERN TRANSVAAL) GOVERNMENT WATER CONTROL AREA.—SCHEDULING BOARD MEETING

It is hereby notified in terms of section 64 of the Water Act, 1956, that a meeting of the Scheduling Board in connection with the schedule of rateable areas of the Crocodile River (Western Transvaal) Government Water Control Area will be held at the office of the Department of Water Affairs at Koedoeskop at 10h00 on Friday, 30 October 1987, for the purpose of hearing and determining claims for inclusion in the said schedule or objections to any of the names, properties or areas included therein.

Copies of the schedule of rateable areas, prepared in terms of section 63 (7) of the said Act, will lie for inspection at the following places from Friday, 16 October 1987:

- (a) Office of the Department of Water Affairs at Koedoeskop.
- (b) Assen Police Station.
- (c) Beestekraal Post Office.
- (d) Koedoeskop Post Office.

Any registered owner of land in the said area who is unable to attend the said meeting may authorise any other person, in writing, to represent him/her at the meeting.

(16 October 1987)

BOARD NOTICE

BOARD NOTICE 63 OF 1987

THE SOUTH AFRICAN NURSING COUNCIL

DESIGNATION OF A MEMBER OF THE COUNCIL FOR THE PERIOD ENDING 31 MARCH 1989

In terms of section 5 (6) of the Nursing Act, Act 50 of 1978, notice is given of the designation of Dr D. J. Jacobs as a member of the Council in terms of sections 5 (1) (f) and 6 (2) of the Act with effect from 14 September 1987, vice Mr H. J. Joubert.

(16 October 1987)

VOORWAARDES VIR DIE PUBLIKASIE VAN WETLIKE KENNISGEWINGS CONDITIONS FOR THE PUBLICATION OF LEGAL NOTICES

Sluitingstye vir die aanname van kennisgewings

1. Die *Staatskoerant* word wekeliks op Vrydag gepubliseer en die sluitingstyd vir die aanname van kennisgewings wat op 'n bepaalde Vrydag in die *Staatskoerant* moet verskyn, is 15h00 op die voorafgaande Vrydag. Indien enige Vrydag saamval met 'n openbare vakansiedag, verskyn die *Staatskoerant* op 'n datum en is die sluitingstye vir die aanname van kennisgewings soos van tyd tot tyd in die *Staatskoerant* bepaal.

2. (1) Wanneer 'n aparte *Staatskoerant* verlang word moet dit drie kalenderweke voor publikasie ingedien word.

(2) Kopie van kennisgewings wat na sluitingstyd ontvang word, sal oorgehou word vir plasing en die eersvolgende *Staatskoerant*.

(3) Wysiging van of veranderings in die kopie van kennisgewings kan nie onderneem word nie tensy opdragte daarvoor ontvang is voor 15h30 op Maandae.

(4) Kopie van kennisgewings vir publikasie of wysigings van oorspronklike kopie kan nie oor die telefoon aanvaar word nie en moet per brief, per telegram of per hand bewerkstellig word.

(5) In geval van kansellering sal die terugbetaling van die koste van 'n kennisgewing oorweeg word slegs as die opdrag om te kanselleer op of voor die vasgestelde sluitingstyd soos in paragraaf 1 hierbo aangedui, ontvang is.

Goedkeuring van kennisgewings

3. Kennisgewings, behalwe wetlike kennisgewings, is onderworpe aan die goedkeuring van die Staatsdrukker wat kan weier om enige kennisgewing aan te neem of verder te publiseer.

Vrywaring van die Staatsdrukker teen aanspreeklikheid

4. Die Staatsdrukker aanvaar geen aanspreeklikheid vir—

- (1) enige vertraging by die publikasie van 'n kennisgewing of vir die publikasie daarvan op 'n ander datum as dié deur die adverteerder bepaal;
- (2) die foutiewe klassifikasie van 'n kennisgewing of die plasing daarvan onder 'n ander afdeling of opskrif as die afdeling of opskrif wat deur die adverteerder aangedui is;
- (3) enige redigering, hersiening, weglating, tipografiese foute of foute wat weens dowwe of onduidelike kopie mag ontstaan.

Aanspreeklikheid van adverteerder

5. Die adverteerder word aanspreeklik gehou vir enige skadevergoeding en koste wat ontstaan uit enige aksie wat weens die publikasie van 'n kennisgewing teen die Staatsdrukker ingestel mag word.

Kopie

6. Die kopie van kennisgewings moet slegs op een kart van die papier getik wees en mag nie deel van enige begeleidende brief of dokument uitmaak nie.

7. Bo aan die kopie, en weg van die kennisgewing, moet die volgende aangedui word:

- (1) Die aard van die kennisgewing;

Let Wel.—Voorreemde adverteerders word hierby dringend versoek om **duidelik aan te dui** onder watter hofie hul advertensies of kennisgewings geplaas moet word om te verhoed dat genoemde advertensies/kennisgewings verkeerd geplaas word.

- (2) die opskrif waaronder die kennisgewing geplaas moet word;
- (3) die tarief (bv. "Vaste tarief", of "Woordetal-tarief") wat op die kennisgewing van toepassing is, en die koste verbonde aan die plasing daarvan.

8. Alle eiename en familienaam moet duidelik leesbaar wees en familienaam moet onderstreep of in hoofletters getik word. Indien 'n naam verkeerd gedruk word as gevolg van onduidelike skrif, sal die kennisgewing alleen na betaling van die koste van 'n nuwe plasing weer gepubliseer word.

Betaling van koste

9. Geen kennisgewing word vir publikasie aanvaar nie tensy die koste van die plasing(s) daarvan vooruit betaal is deur middel van ongekanselleerde inkomstestempels.

Frankemasjien-afdrukke op kopie is aanvaarbaar mits afdrukke duidelik is. Frankemasjien-afdrukke op enige ander wyse aangebring bv. op los papier wat op kopie geplak word is nie aanvaarbaar nie.

Closing times for the acceptance of notices

1. The *Government Gazette* is published every week on Friday, and the closing time for the acceptance of notices which have to appear in the *Government Gazette* on any particular Friday, is 15h00 on the preceding Friday. Should any Friday coincide with a public holiday, the date of publication of the *Government Gazette* and the closing time of the acceptance of notices will be published in the *Government Gazette*, from time to time.

2. (1) The copy for a separate *Government Gazette* must be handed in not later than three calendar weeks before date of publication.

(2) Copy of notices received after closing time will be held over for publication in the next *Government Gazette*.

(3) Amendment or changes in copy of notices cannot be undertaken unless instructions are received **before 15h30 on Mondays**.

(4) Copy of notices for publication or amendments of original copy cannot be accepted over the telephone and must be brought about by letter, by telegram or by hand.

(5) In the case of cancellations a refund of the cost of a notice will be considered only if the instruction to cancel has been received on or before the stipulated closing time as indicated in paragraph 1 above.

Approval of notices

3. Any notices other than legal notices are subject to the approval of the Government Printer, who may refuse acceptance or further publication of any notice.

The Government Printer indemnified against liability

4. The Government Printer will assume no liability in respect of—

- (1) any delay in the publication of a notice or publication of such notice on any date other than that stipulated by the advertiser;
- (2) erroneous classification of a notice, or the placement of such notice in any section or under any heading other than the section or heading stipulated by the advertiser;
- (3) any editing, revision, omission, typographical errors or errors resulting from faint or indistinct copy.

Liability of advertiser

5. Advertisers will be held liable for any compensation and costs arising from any action which may be instituted against the Government Printer in consequence of the publication of any notice.

Copy

6. Copy of notices must be typed on one side of the paper only and may not constitute part of any covering letter or document.

7. At the top of any copy, and set well apart from the notice the following must be stated:

- (1) The kind of notice;

Please note.—Prospective advertisers are urgently requested to **clearly indicate** under which headings their advertisements or notices should be inserted in order to prevent such notices/advertisements from being wrongly placed.

- (2) the heading under which the notice is to appear;
- (3) the rate (e.g. "Fixed tariff rate", or "Word count rate") applicable to the notice, and the cost of publication.

8. All proper names and surnames must be clearly legible, surnames being underlined or typed in capital letters. In the event of a name being incorrectly printed as a result of indistinct writing, the notice will be republished only upon payment of the cost of a new insertion.

Payment of cost

9. No notice will be accepted for publication unless the cost of the insertion(s) is prepaid by way of uncanceled revenue stamps.

Franking machine impressions appearing on the copy are acceptable provided that they are clear. Franking machine impressions other than the aforementioned, for example, on a separate sheet of paper pasted to the copy are not acceptable.

10. (1) Die koste van 'n kennisgewing moet deur die adverteerder bereken word in ooreenstemming met—

- (a) die lys van vaste tariewe; of
- (b) indien die vaste tariewe nie van toepassing is nie, die woorde-tal-tariewe.

(2) In gevalle van twyfel oor die koste verbonde aan die plasing van 'n kennisgewing en in die geval van kopie met meer as 1 600 woorde, moet 'n navraag, vergesel van die betrokke kopie, voor publikasie aan die Advertensie-afdeling, Staatsdrukkery, Privaatsak X85, Pretoria, 0001, gerig word.

11. Ongekanselleerde inkomsteseëls wat die juiste bedrag van die koste van 'n kennisgewing of die totaal van die koste van meerdere kennisgewings verteenwoordig, moet op die kopie geplak word.

Die volgende seëls is nie aanvaarbaar nie:

- (i) Inkomsteseëls van die ou reëks.
- (ii) Inkomsteseëls van ander state.
- (iii) Posseëls.

12. Oorbetalings op grond van 'n foutiewe berekening van die koste verbonde aan die plasing van 'n kennisgewing deur die adverteerder word nie terugbetaal nie tensy die adverteerder voldoende redes aantoon waarom 'n foutiewe berekening gemaak is. In die geval van onderbetalings sal die verskil van die adverteerder verhaal word en geen plasing sal geskied voordat die volle koste verbonde aan die plasing van die kennisgewing(s) deur middel van ongekanselleerde inkomsteseëls betaal is nie.

13. Die Staatsdrukker behou hom die reg voor om 'n bykomende bedrag te hef in gevalle waar kennisgewings, waarvan die koste in ooreenstemming met die lys van vaste tariewe bereken word, later uitermatig lank blyk te wees of buitensporige of ingewikkelde tabelwerk bevat.

Bewys van publikasie

14. Eksemplare van die *Staatskoerant* wat nodig mag wees ter bewys van publikasie van 'n kennisgewing kan teen 50c verkoopbelasting uitgesluit in die vorm van ongekanselleerde inkomsteseëls per eksemplaar van die Staatsdrukker bestel word. Geen aanspreeklikheid word aanvaar vir die versuim om sodanige *Staatskoerant(e)* te pos of vir vertraging in die versending daarvan nie.

Geklassifiseerde wetlike kennisgewings moet op die voorgeskrewe vorm ingedien word; kyk die volgende bladsye. Hierdie vorms mag vryelik gereproduseer word onder 'n algemene kopieregvergunning wat die Staatsdrukker hiervoor verleen. Waar vorms getik word, moet by die uitleg, styl en in besonder die nommering gehou word. Seëls moet esseblief vasgeplak word.

10. (1) The cost of a notice must be calculated by the advertiser in accordance with—

- (a) the list of fixed tariff rates; or
- (b) where the fixed tariff rate does not apply, the word count rate.

(2) Where there is any doubt about the cost of publication of a notice, and in the case of copy in excess of 1 600 words, an enquiry, accompanied by the relevant copy should be addressed to the Advertising Section, Government Printing Works, Private Bag X85, Pretoria, 0001, before publication.

11. Uncancelled revenue stamps representing the correct amount of the cost of publication of a notice, or the total of the cost of publication of more than one notice, must be affixed to the copy.

The following stamps are not acceptable:

- (i) Revenue stamps of the old series.
- (ii) Revenue stamps of other states.
- (iii) Postage stamps.

12. Overpayments resulting from miscalculation on the part of the advertiser of the cost of publication of a notice will not be refunded, unless the advertiser furnishes adequate reasons why such miscalculation occurred. In the event of underpayments, the difference will be recovered from the advertiser, and the notice(s) will not be published until such time as the full cost of such publication has been duly paid in uncancelled revenue stamps.

13. The Government Printer reserves the right to levy an additional charge in cases where notices, the cost of which has been calculated in accordance with the list of fixed tariff rates, are subsequently found to be excessively lengthy or to contain overmuch or complicated tabulation.

Proof of publication

14. Copies of the *Government Gazette* which may be required as proof of publication may be ordered from the Government Printer at 50c sales tax excluded, payment to be effected by way of uncancelled revenue stamps. The Government Printer will assume no liability for any failure to post such *Government Gazette(s)* or for any delay in dispatching it/them.

Classified legal advertisements must be submitted on the prescribed form; vide the following pages. These forms may be freely reproduced under a general copyright authority granted for this purpose by the Government Printer. Where forms are typed, the lay-out, style and especially the numbering must be adhered to. Stamps must be affixed, please.

LYS VAN VASTE TARIWE EN VOORWAARDES VIR DIE PUBLIKASIE VAN WETLIKE KENNISGEWINGS IN DIE STAATSKOERANTVANAF 1 APRIL 1987

LIST OF FIXED TARIFF RATES AND CONDITIONS FOR THE PUBLICATION OF LEGAL NOTICES IN THE GOVERNMENT GAZETTEFROM 1 APRIL 1987

LYS VAN VASTE TARIWE

<i>Gestandaardiseerde kennisgewings</i>	Tarief per plasing
	R
Besigheidskennisgewings	8,00
Boedelwettekennisgewings: Vorms J 297, J 295, J 193 en J 187	3,50
Derdeparty-assuransie-eise om skadevergoeding Vorm MVA	4,00
Insolvensiewet- en maatskappywettekennisgewings: J 28, J 29, Vorms 1 tot 9	7,00
L.W.—Vorms 2 en 9—bykomstige verklarings volgens woordetal-tabel, toegevoeg tot die basiese tarief.	
Naamsverandering (twee plasinge)	35,00
Onopgeëiste geld—slegs in die buitengewone <i>Staatskoerant</i> , sluitingsdatum 15 Januarie (per inskrywing van 'n "naam, adres en bedrag")	1,50
Slagterskennisgewings	8,00
Slumopruimingshofkennisgewings, per taal, per perseel ...	7,00
Verlore lewensversekeringspolissee Vorm VL	3,50

LIST OF FIXED TARIFF RATES

<i>Standardised notices</i>	Rate per insertion
	R
Administration of Estates Acts notices: Forms J 297, J 295, J 193 and J 187	3,50
Business notices	8,00
Butcher's notices	8,00
Change of name (two insertions)	35,00
Insolvency Act and Company Acts notices: J 28, J 29, Forms 1 to 9	7,00
N.B.—Forms 2 and 9—additional statements according to word count table, added to the basic tariff.	
Lost life insurance policies Form VL	3,50
Slum Clearance Court notices, per language per premises	7,00
Third party insurance claims for compensation Form MVA	4,00
Unclaimed moneys—only in the extraordinary <i>Government Gazette</i> , closing date 15 January (per entry of "name, address and amount")	1,50

Nie-gestandaardiseerde kennisgewings	Tarief per plasing R	Non-standardised notices	Rate per insertion R
Dranklisensie-kennisgewings in buitengewone <i>Staatskoerant</i> :		Company notices:	
(i) Transvaal verskyn voorlaaste Vrydag in Junie. Sluitingsdatum vir indiening eerste Vrydag in Junie	11,50	Short notices: Meetings, resolutions, offer of compromise, conversion of company, voluntary windings-up; closing of transfer or members' registers and/or declaration of dividends.....	17,00
(ii) Kaap, verskyn voorlaaste Vrydag in November. Sluitingsdatum vir indiening eerste Vrydag in November.....	11,50	Declaration of dividend with profit statements, including notes.....	39,50
(iii) OVS verskyn voorlaaste Vrydag in Januarie. Sluitingsdatum vir indiening eerste Vrydag in Januarie.....	11,50	Long notices: Transfer, changes with respect to shares or capital, redemptions, resolutions, voluntary liquidations.....	60,00
(iv) Natal verskyn voorlaaste Vrydag in April. Sluitingsdatum vir indiening eerste Vrydag in April	11,50	Liquidator's and other appointees' notices.....	11,50
Laat aansoeke vir plasing in gewone <i>Staatskoerant</i>	79,50	Liquor Licence notices in extraordinary <i>Gazette</i> :	
Geregteelike en ander openbare verkope:		(i) Transvaal appear on last Friday but one in June. Closing date for acceptance first Friday in June.....	11,50
Geregteelike verkope.....	29,50	(ii) Cape appear on last Friday but one in November. Closing date for acceptance first Friday in November.....	11,50
Openbare veilings, verkope en tenders:		(iii) OVS appear on last Friday but one in January. Closing date for acceptance first Friday in January	11,50
Tot 75 woorde.....	9,00	(iv) Natal appear on last Friday but one in April. Closing date for acceptance first Friday in April.....	11,50
76 tot 250 woorde.....	24,00	Late applications for publication in ordinary <i>Government Gazette</i>	79,50
251 tot 350 woorde (meer as 350 woorde bereken volgens woordetal-tabel).....	37,00	Orders of the Court:	
Handelsmerke in Suidwes-Afrika (volgens sentimeter tarief vir departemente)		Provisional and final liquidations or sequestrations.....	22,50
Likwidateurs en ander aangesteltes se kennisgewings ...	11,50	Reductions or changes in capital, mergers, offer of compromise.....	60,00
Maatskappykennisgewings:		Judicial managements, <i>curator bonus</i> and similar and extensive rules <i>nisi</i>	60,00
Kort kennisgewings: Vergaderings, besluite, aanbod van skikking, omskepping van maatskappy, vrywillige likwidasies, ens.; sluiting van oordrag- of lederegisters en/of verklaring van dividende.....	17,00	Extension of return date.....	7,00
Verklaring van dividende met profytstate, notas ingesluit.....	39,50	Supersessions and discharge of petitions (J 158).....	7,00
Lang kennisgewings: Oordragte, veranderings met betrekking tot aandele of kapitaal, aflossings, besluite, vrywillige likwidasies.....	60,00	Sales in executions and other public sales:	
Orders van die Hof:		Sales in execution.....	29,50
Voorlopige en finale likwidasies of sekwestrasies.....	22,50	Public auctions, sales and tenders:	
Verlagings of veranderings in kapitaal, samesmeltings, aanbod van skikking.....	60,00	Up to 75 words.....	9,00
Geregteelike besture, <i>curator bonis</i> en soortgelyke en uitgebreide bevele <i>nisi</i>	60,00	76 to 250 words.....	24,00
Verlenging van keerdatum.....	7,00	251 to 350 words (more than 350 words—calculate in accordance with word count table)	37,00
Tersydestelling en afwysings van petisies (J 158).....	7,00	Trade Marks in South West Africa (according to centimetre tariff for department)	

WOORDETAL-TABEL

Vir algemene kennisgewings wat nie onder bovermelde opskrifte met vaste tariewe ressorteer nie en wat 1 600 of minder woorde beslaan, moet die tabel van woordetal-tariewe gebruik word. Kennisgewings met meer as 1 600 woorde, of waar twyfel bestaan, moet vooraf ingestuur word soos in die Voorwaardes par. 10 (2), voorgeskryf:

Aantal woorde in kopie Number of words in copy	Een plasing One insertion	Twee plasinge Two insertions	Drie plasinge Three insertions
	R	R	R
1- 100.....	11,50	18,50	27,50
101- 150.....	17,00	24,00	37,00
151- 200.....	23,00	31,00	46,00
201- 250.....	29,00	38,00	55,00
251- 300.....	34,50	45,00	64,50
301- 350.....	40,00	52,00	73,50
351- 400.....	46,00	58,50	83,00
401- 450.....	52,00	65,50	92,00
451- 500.....	57,50	72,50	101,00
501- 550.....	63,00	79,50	110,50
551- 600.....	69,00	86,00	119,50
601- 650.....	75,00	93,00	129,00
651- 700.....	80,50	100,00	138,00
701- 750.....	86,00	107,00	147,00
751- 800.....	92,00	114,00	156,50
801- 850.....	98,00	121,00	165,50
851- 900.....	103,50	127,50	175,00
901- 950.....	109,00	134,50	184,00
951-1 000.....	115,00	141,50	193,00
1 001-1 300.....	149,50	183,00	248,50
1 301-1 600.....	184,00	224,00	303,50

WORD COUNT TABLE

For general notices which do not belong under above-mentioned headings with fixed tariff rates and which comprise 1 600 or less words, the rates of the word count table must be used. Notices with more than 1 600 words, or where doubt exists, must be sent in before publication as prescribed in par. 10 (2) of the Conditions.

AANSOEKE OM OPENBARE PADVERVOERPERMITTE
Sluitingstye vir die aanname van kennisgewings
 Kennisgewings moet nie later as 15h00 op die Vrydag, twee kalenderweke voor datum van publikasie, ingedien word nie.

APPLICATIONS FOR PUBLIC ROAD CARRIER PERMITS
Closing times for the acceptance of notices
 Notices must be handed in not later than 15h00 on the Friday, two calendar weeks before the date of publication.

DIE STAATSDRUKKER**AMPTELIKE PUBLIKASIES ONTVANG
GEDURENDE JULIE 1987***(Alle binnelandse pryse is onderhewig aan algemene verkoopbelasting)***RP-VERSLAE**

Verslag No. RP 40/1987—S.A. Regskommissie se Veertiende Jaarverslag, 1986. ISBN 0 621 10711 5. Plaaslik R3,10, buitelandse R3,75.

Verslag No. RP 54/1987—Jaarverslag van die Departement van Nasionale Opvoeding, 1986. ISBN 0 7970 1160 9. Plaaslik R5,90, buitelandse R7,10.

Verslag No. RP 79/1987—Verslag van die Direkteur-generaal van die Departement van Mannekrag vir die jaar geëindig 31 Desember 1986. ISBN 0 621 11040 X. Plaaslik R22,50, buitelandse R28,15.

Verslag No. WPE-87—Verslag oor die Voorgestelde Waterbesoedelings-beheerwerke by Geslote Steenkoolmyne in Noord-Natal. ISBN 0 621 10408 6. Plaaslik R3,20, buitelandse R4.

STATISTIEKE VERSLAE

Verslag No. 06-01-18—Sensus van Landbou, 1981: Landbougewasse: voer- en weidingsgewasse, groente, vrugte en neute. ISBN 0 621 10730 1. Plaaslik R2,10, buitelandse R2,50.

Verslag No. 06-01-19—Sensus van Landbou, 1981: Lewende hawe en pluimvee; landboumasjinerie, toerusting en implimente; voertuie en elektrisiteit. ISBN 0 621 10764 6. Plaaslik R2,10, buitelandse R2,50.

Verslag No. 07-07-03—Lopende Bevolkingsopname: Kleurlinge, Asiërs en Swartes, 1985. ISBN 0 621 10599 6. Plaaslik R2,10, buitelandse R2,50.

Verslag No. 11-01-20—Pryse: Huise en Huisbediendes; en Woonstelle, 1985. ISBN 0 621 10198 2. Plaaslik R2,10, buitelandse R2,50.

Verslag No. 12-02-17—Nuwe Voertuie Geregistreer, 1984/85. ISBN 0 621 10701 8. Plaaslik R2,10, buitelandse R2,50.

Verslag No. 12-02-18—Nuwe Voertuie Geregistreer, 1985/86. ISBN 0 621 10734 4. Plaaslik R2,10, buitelandse R2,50.

Verslag No. 21-04-17—Onderwys: Indiërs, 1983. ISBN 0 621 10735 2. Plaaslik R2,10, buitelandse R2,50.

Bulletin van Statistieke vir die kwartaal geëindig Junie 1987. Plaaslik R4,20, buitelandse R5.

DIVERSE VERSLAE

"S.A. Law Commission Report: Research Series 4, Volume 8. Index to the Opinions of Roman-Dutch Lawyers and the Decisions of the Courts of The Netherlands which have been digested in the Algemeen Beredeneerd Register of Nassau La Leck (1741-1795)". ISBN 0 621 10709 3. Plaaslik R7,20, buitelandse R8,65.

"S.A. Law Commission Report: Research Series 10. Treatise on the Quasi-contract called Promutuum and on the Condictio Indebiti". ISBN 0 621 10722 0. Plaaslik R2,35, buitelandse R2,80.

"S.A. Law Commission Report: Research Series 11, Volume 1. Quaestiones Juris Privati". ISBN 0 621 10657 7. Plaaslik R8,60, buitelandse R10,35.

"S.A. Law Commission Report: Research Series 11, Volume 2. Quaestiones Juris Privati". ISBN 0 621 10675 5. Plaaslik R11,50, buitelandse R13,80.

"Food Preservation: Revised Metricated Edition". ISBN 0 621 10712 3. Plaaslik R9,70, buitelandse R11,60.

Argiefjaarboek, 1987, Deel 11: Die Berlynse Sendinggenootskap en Kerkstigting in Transvaal 1904-1962. Plaaslik R6,30, buitelandse R8,40.

Gebinde *Staatskoerante* vir die maand Februarie 1987. Plaaslik R25, buitelandse R31,25.

Gebinde *Staatskoerante* vir die maand Maart 1987. Plaaslik R25, buitelandse R31,25.

Gebinde *Staatskoerante* vir die maand April 1987. Plaaslik R25, buitelandse R31,25.

THE GOVERNMENT PRINTER**OFFICIAL PUBLICATIONS RECEIVED
DURING JULY 1987***(All local prices are subject to general sales tax)***RP REPORTS**

Report No. RP 40/1987—S.A. Law Commission Fourteenth Annual Report, 1986. ISBN 0 621 10711 5. Local R3,10, other countries R3,75.

Report No. RP 54/1987—Department of National Education Annual Report, 1986. ISBN 0 7970 1160 9. Local R5,90, other countries R7,10.

Report No. RP 79/1987—Director-General Report of the Department of Manpower for the year ending 31 December 1986. ISBN 0 261 11040 X. Local R22,50, other countries R28,15.

Report No. WPE-87—Report on the Proposed Water Pollution Control Works at Abandoned Coal Mines in Northern Natal. ISBN 0 621 10408 6. Local R3,20, other countries R4.

STATISTICAL REPORTS

Report No. 06-01-18—Census of Agriculture, 1981: Agricultural products; fodder and pastoral products, vegetables, fruit and nuts. ISBN 0 621 10730 1. Local R2,10, other countries R2,50.

Report No. 06-01-19—Census of Agriculture, 1981: Livestock and poultry; agricultural machinery, equipment and implements; vehicles and electricity. ISBN 0 621 10764 6. Local R2,10, other countries R2,50.

Report No. 07-07-03—Current Population Survey: Coloureds, Asians and Blacks, 1985. ISBN 0 621 10599 6. Local R2,10, other countries R2,50.

Report No. 11-01-20—Prices: Houses and Domestic Servants; and Flats, 1985. ISBN 0 621 10198 2. Local R2,10, other countries R2,50.

Report No. 12-02-17—New Vehicles Registered, 1984/85. ISBN 0 621 10701 8. Local R2,10, other countries R2,50.

Report No. 12-02-18—New Vehicles Registered 1985/86. ISBN 0 621 10734 4. Local R2,10, other countries R2,50.

Report No. 21-04-17—Education: Indians, 1983. ISBN 0 621 10735 2. Local R2,10, other countries R2,50.

Bulletin of Statistics for the quarter ended June 1987. Local R4,20, other countries R5.

MISCELLANEOUS REPORTS

S.A. Law Commission Report: Research Series 4, Volume 8. Index to the Opinions of Roman-Dutch Lawyers and the Decisions of the Courts of The Netherlands which have been digested in the Algemeen Beredeneerd Register of Nassau La Leck (1741-1795). ISBN 0 621 10709 3. Local R7,20, other countries R8,65.

S.A. Law Commission Report: Research Series 10. Treatise on the Quasi-contract called Promutuum and on the Condictio Indebiti. ISBN 0 621 10722 0. Local R2,35, other countries R2,80.

S.A. Law Commission Report: Research Series 11, Volume 1. Quaestiones Juris Privati. ISBN 0 621 10657 7. Local R8,60, other countries R10,35.

S.A. Law Commission Report: Research Series 11, Volume 2. Quaestiones Juris Privati. ISBN 0 621 10675 5. Local R11,50, other countries R13,80.

Food Preservation: Revised Metricated Edition. ISBN 0 621 10712 3. Local R9,70, other countries R11,60.

Archives Year Book, 1987, Part 11: "Die Berlynse Sendinggenootskap en Kerkstigting in Transvaal, 1904-1962". Local R6,30, other countries R8,40.

Bound Volume of *Government Gazettes* for the month of February 1987. Local R25, other countries R31,25.

Bound Volume of *Government Gazettes* for the month of March 1987. Local R25, other countries R31,25.

Bound Volume of *Government Gazettes* for the month of April 1987. Local R25, other countries R31,25.

LANDKAARTE			MAPS		
1:50 000			1:50 000		
Nuwe uitgawes			New editions		
	<i>Uitgawe</i>	<i>Datum van inligting</i>		<i>Edition</i>	<i>Date of information</i>
3017BA—Soebatsfontein.....	Tweede	1986	3017BA—Soebatsfontein.....	Second	1986
3018AC—Leliefontein.....	Tweede	1986	3018AC—Leliefontein.....	Second	1986
3018AD—Platbakkies.....	Tweede	1986	3018AD—Platbakkies.....	Second	1986
1:50 000			1:50 000		
Herdrukke			Reprints		
2327CC—Kiesel.....	Tweede	1980	2327CC—Kiesel.....	Second	1980
2430BB—Mica.....	Tweede	1975	2430BB—Mica.....	Second	1975
2528CB—Silverton.....	Vierde	1975	2528CB—Silverton.....	Fourth	1975
2528CD—Rietvleidam.....	Vierde	1975	2528CD—Rietvleidam.....	Fourth	1975
2530CB—Waterval Boven.....	Eerste	1969	2530CB—Waterval Boven.....	First	1969
2531DC—Mgobode.....	Eerste	1967	2531DC—Mgobode.....	First	1967
2531DD—Figtree.....	Eerste	1967	2531DD—Figtree.....	First	1967
2625BC—Deelpan.....	Eerste	1972	2625BC—Deelpan.....	First	1972
2625BD—Biesiesvlei.....	Eerste	1972	2625BD—Biesiesvlei.....	First	1972
2627AD—Carletonville.....	Tweede	1976	2627AD—Carletonville.....	Second	1976
2628AB—Benoni.....	Vierde	1983	2628AB—Benoni.....	Fourth	1983
2630BD—Bell's Kop.....	Tweede	1969	2630BD—Bell's Kop.....	Second	1969
2727BA—Koppies.....	Tweede	1976	2727BA—Koppies.....	Second	1976
3225BA—Cradock.....	Tweede	1973	3225BA—Cradock.....	Second	1973
3418AB + AD—Kaapse Skiereiland.....	Vyfde	1983	3418AB + AD—Kaapse Skiereiland.....	Fifth	1983
1:250 000			1:250 000		
Topografies			Topographical		
3420—Riversdale.....	Vierde	1985	3420—Riversdale.....	Fourth	1985
1:250 000			1:250 000		
Topo-kadastraal			Topo Cadastral		
3420—Riversdale.....	Vierde	1985	3420—Riversdale.....	Fourth	1985
1:1 000 000			1:1 000 000		
Lugoordrukke			Lugoordrukke		
3300—Johannesburg.....	Derde	1980	3300—Johannesburg.....	Third	1980
3301—Vryburg.....	Tweede	1978	3301—Vryburg.....	Second	1978
3396—Calvinia.....	Tweede	1976	3396—Calvinia.....	Second	1976
3397—Bloemfontein.....	Derde	1979	3397—Bloemfontein.....	Third	1979
3398—Durban.....	Vierde	1983	3398—Durban.....	Fourth	1983
3421—Port Elizabeth.....	Tweede	1976	3421—Port Elizabeth.....	Second	1976
3422—Cape Town.....	Tweede	1976	3422—Cape Town.....	Second	1976
Plaaslik R1, buitelands R1,25.			Local R1, other countries R1,25.		

BELANGRIKE AANKONDIGING

SLUITINGSTYF VIR WETLIKE KENNISGEWINGS EN GOEWERMENSKENNISGEWINGS

1987

Die sluitingstyd is stiptelik 15h00 op die volgende dae:

- 10 Desember, Donderdag, vir die uitgawe van Vrydag 18 Desember.
- 15 Desember, Dinsdag, vir die uitgawe van Donderdag 24 Desember.
- 22 Desember, Dinsdag, die die uitgawe van Donderdag 31 Desember.
- 30 Desember, Woensdag, vir die uitgawe van Vrydag 8 Januarie 1988.

Laat kennisgewings sal in die daaropvolgende uitgawe geplaas word. Indien 'n laat kennisgewing wel, onder spesiale omstandighede aanvaar word, sal 'n dubbeltarief gehêf word.

Wanneer 'n aparte Staatskoerant verlang word moet die kopie drie kalenderweke voor publikasie ingedien word.

IMPORTANT ANNOUNCEMENT

CLOSING TIMES FOR LEGAL NOTICES AND GOVERNMENT NOTICES

1987

The closing time is 15h00 sharp on the following days:

- 10 December, Thursday, for the issue of Friday 18 December.
- 15 December, Tuesday, for the issue of Thursday 24 December.
- 22 December, Tuesday, for the issue of Thursday 31 December.
- 30 December, Wednesday, for the issue of Friday 8 January 1988.

Late notices will be published in the subsequent issue. If, under special circumstances, a late notice is being accepted, a double tariff will be charged.

The copy for a separate Government Gazette must be handed in not later than three calendar weeks before date of publication.

BESIGHEIDSKENNISGEWINGS • BUSINESS NOTICES

VERVREEMDING, VERKOPE, VERANDERING VAN VENNOOTSKAP, NAAM, ADRES, ENS.

Kennisgewing geskied hiermee ingevolge die bepalings van artikel 34 (1) van die Insolvensiewet, No. 24 van 1936, aan belanghebbende partye en skuldeisers van voorgenome vervreemding van besighede en/of klandisie, goedere of eiendom wat 'n deel vorm van besighede, na 'n tydperk van 30 dae vanaf die laaste publikasie van betrokke advertensies, en van aksies, omstandighede of voorwaardes wat op besighede of partye of skuldenaars, soos daarin genoem, betrekking het.

Die inligting word, waar van toepassing, verstrekk in die volgorde: (1) Dorpsgebied of distrik, afdeling, county; (2) verkoper, handelaar, vennootskap; (3) besigheid of handel, soort, naam en/of styl, en adres waar gedryf; (4) doel en voorneme (vervreemding, verkoop, oorgawe, verandering of ontbinding van vennootskap, verhuising of adresverandering, naamverandering, kansellasië van verkoop, ens.); voorwaardes, en datum of tydperk indien anders as 30 dae; (5) koper, nuwe besitter en/of eienaar of vennoot, of kontrakterende party; (6) besigheid en adres, indien anders as onder (3); opmerkings, kommentaar; (7) adverteerder en/of agent, adres en datum.

ALIENATION, SALES, CHANGES OF PARTNERSHIP, NAME, ADDRESS, ETC.

Notice is hereby given in terms of section 34 (1) of the Insolvency Act, No. 24 of 1936, to interested parties and creditors of the intention of alienation of business and/or goodwill, goods or property forming part of businesses, after a period of 30 days from the last publication of relevant advertisements, and of actions, circumstances or conditions pertaining to businesses or parties or debtors, as mentioned therein.

The information, where applicable, is given in the following order: (1) Township or district, division, county; (2) seller, trader, partnership; (3) business or trade, kind, name and/or style, and the address at which carried on; (4) purpose and intent (alienation, sale, abandonment, change or dissolution of partnership, removal or change of address, change of name, cancellation of sale, etc.); conditions, and date or period of time if other than 30 days; (5) purchaser, new proprietor and/or owner or partner, or contracting party; (6) business and address, if other than under (3); notes, comment; (7) advertiser and/or agent, address and date.

TRANSVAAL

Benoni. (2) Louis Phillippus van Rensburg. (3) Goodlife Health Centre, being a gymnasium and health centre business at Alphen Park Shopping Centre, Mercury Street, Benoni. (4) 31 October 1987. (5) Victor Raymond Teaman. (6)—. (7) Gilchrist & Reid, P.O. Box 356, Benoni (Medical Centre, Rothsay Street, Benoni).

Benoni. (2) Anthony Costa Tritis. (3) Imperial Jewellers, Shop No. 5, Commercial House, Cranbourne Avenue, Benoni. (4) Sale. (5) Willem Petrus Woudberg. (6)—. (7) Lovell, Miller, Dreyer & Kraitzick, Attorneys for Seller, 32 Cranbourne Avenue, Benoni. Wustrow, Nel & Saayman, Attorneys for Purchaser, 25 Long Street, Kempton Park.

Johannesburg. (2) Jose Afonso Gomes. (3) Siesta Food Centre, at 24 Twist Street, Johannesburg. (4) Disposition. (5) Abilio Corte Ave Maria da Silva. (6)—. (7) Hertzberg—Margolis, P.O. Box 6892, Johannesburg, 1 October 1987.

Kempton Park. (2) Antonio Nunes Ideia. (3) Central Cafe & Take-Away & Fish and Chips, Holding 250, Bredell Small Holdings, District of Kempton Park, 1620. (4) Sale. (5) Antonio Duarte Jardim. (6)—. (7) Galloways, Bezuidenhout Building, 245 Commissioner Street, P.O. Box 322, Boksburg, 1460, 25 September 1987.

Alberton. (2) Meletios Koufis. (3) The Alberton Golf Driving Range and Entertainment Centre, St Austrial Street, New Redruth, Alberton. (4) Sale with retrospective effect from 19 September 1987. (5) Alberton Golf Driving Range CC (CK87/21697/23). (6)—. (7) Hammerschlag-Gishen Inc., P.O. Box 184, Springs, 1560, 28/9/87.

Potchefstroom. (2) Manuel Loes Pereira da Costa. (3) Panorama Kafee, Kerkstraat 209, Potchefstroom. (4) Verkoop. (5) Carlos Manuel de Oliveira. (6)—. (7) Kruger & Naude, Posbus 20, Potchefstroom.

Klerksdorp. (2) Willem Petrus Roos. (3) Elwil Motors, Teaklaan 17, Industriële Gebied, Klerksdorp. (4) Verkoop. (5) Petrus Johannes van Wyngaard. (6)—. (7) J. J. Oosthuizen, Du Plooy & Vennote, Posbus 22, Klerksdorp, 2570.

Heidelberg. (2) Wilhelmina Adolfinia Wiese en Catharina Jacoba Lombard. (3) Die Baksusters, Winkel No. 3, Pretoriusstraat 59, Heidelberg, 2400. (4) Verkoop is 30 (dertig) dae; Voorwaardes soos vervat in ooreenkoms gesluit op die 8ste September 1987 ter insae by die Verkoper se prokureurs, Viljoen & Meek, Voortrekkerstraat 29, Heidelberg (Verw. Mnr. I. J. du P. van den Berg). (5) Soria Aldim. (6)—. (7) Viljoen & Meek, Voortrekkerstraat 29, Posbus 21, Heidelberg, 2400.

SALE OF BUSINESS

Notice is hereby given in terms of Section 34 of Act No. 24 of 1936, as amended, that it is the intention of **Manuel Pio Dias Goncalves** carrying on business under the style of **Chickenland** at 117 Main Street Kenilworth Johannesburg, to dispose of the said business together with all the assets thereof after the expiration of a period of 30 (thirty) days from the date of last publication hereof, to **Chickenland (Proprietary) Limited** No. 87/04022/07, which will thereafter carry on the said business at the same address under the same style for its own account and benefit.

Dated at Johannesburg this 5th day of October 1987.

Gerings, Attorneys for Parties, 4th Floor, His Majesty's Building, Cnr. Commissioner & Eloff Streets, Johannesburg, 2000.

Middelburg. (2) Frank Jacobus de Villiers. (3) Frank's Cafe h/v Jan van Riebeeck- en Jeppestraat, Middelburg. (4) Verkoop/Sale. (5) José Manuel Fernandes. (6)—. (7) Esterhuysen Botha & Van der Walt, Posbus 509, Middelburg.

KENNISGEWING VAN VERKOOP VAN BESIGHEID

Kennis word hiermee gegee ingevolge Artikel 34 van Wet No. 24 van 1936, (soos gewysig), dat **Jacob Johannes van der Heyde** wat as 'n Droogskoonmaker sake doen te Schoemanstraat 182, Pretoria, voornemens is om die besigheid wat bedryf word as **Aqua Droogskoonmakers**, tesame met al die bates daarvan te vervreem en oor te dra aan **Catharina Petronella Bezuidenhout** wat genoemde besigheid sal voortsit onder dieselfde naam vir haar eie voordeel en rekening nadat 'n tydperk van 30 (dertig) dae vanaf die eerste publikasie hiervan verstryk het.

Business Exchange (Eiendoms) Beperk, Makelaars vir die partye, Louis Pasteurgebou 904, Schoemanstraat 374, Pretoria.

Pietersburg en Kempton Park. (2) James Cornelius Gouws en Paul Jacobus Jacobs. (3) Turbo Services te Riggerweg 65, Spartan, Kempton Park en Ysterstraat 28, Pietersburg. (4) Vervreemding. (5) Jan Adriaan Venter, John Pieter Pretorius en Johannes Jacobus Grobbelaar. (6)—. (7) Coetzee & Van der Merwe, Prokureurs vir Partye, Posbus 217, Phalaborwa.

DISSOLUTION OF PARTNERSHIP

Notice is hereby given that the partnership of **Bryan Edward Gouldie** and **Alan Merifield** trading as **Albry Timbers** at 2 Carel Lotter Street, Nuffield, Springs was dissolved with effect from the 7th October 1986. From that date **Alan Merifield** continued to conduct the said business at the said address under the same name and style for his own benefit.

Clifford St John Wills, Attorney for the Parties, Second Floor, Barclays Bank Building, Third Street, P.O. Box 738, Springs, 1560.

Krugerdsorp. (2) Ou Kraal CC. (3) Ou Kraal Butchery at 30b President Street, Krugerdsorp, 1740. (4) Sale. (5) Jose Jorge de Freitas and Franklin Menezes. (6)—. (7) J. B. Hugo & Cronje, Attorneys for parties, Allied House, Second Floor, c/o Human & Market Streets, Krugerdsorp, 1740, 5 October 1987.

Johannesburg. (2) Natvarlal Ratanjee Parbhoo. (3) Bombay Tailors, 130a Jeppe Street, Johannesburg. (4) Sale. (5) Harilal Sookha. (6)—. (7) Bhana, Wadee, Nanabhay & Chibabhai, P.O. Box 769, Lenasia, 1820.

SALE OF BUSINESS

In terms of Section 34 (1) of the Insolvency Act No. 24 of 1936, **Elizabeth Abrahams**, conducting business under the name and style of "**Clippers Hair**" at Shop numbers 1 and 2, Zappion Court, Corner of Scott and Knox Streets, Waverley, Johannesburg, hereby gives notice of her intended sale of the aforesaid business 30 (thirty) days after publication of this advertisement to **Anthony Levy** of Shop numbers 1 and 2, Zappion Court, Corner Scott and Knox Streets, Johannesburg.

Roodepoort. (2) Lunba (Proprietary) Limited. (3) Lumbella, Shop 21, Westgate Shopping Centre, Roodepoort. (4) Sale. (5) Anthony Brian Goodman in his capacity as a trustee for a close corporation to be formed. (6)—. (7) Joffe Kobrin & Lacob, P.O. Box 52689, Saxonwold, 2132.

NOTICE

Notice is hereby given in terms of section 34 of the Insolvency Act No. 24 of 1936, as amended, that **Kelvin Young** has agreed to sell the business known as **Seafood Tavern** situated at 9 Royal York Building, Voortrekker Street, New Redruth, Alberton, together with goodwill, stock, fixtures and fittings, thirty days after the date of this notice to **Martin Johan Hendrik Romkes** who will trade under the name of **Seafood Tavern** for his own benefit.

Gold Estates, P.O. Box 1140, Saxonwold, 2126.

NOTICE

Notice is hereby given in terms of section 34 of the Insolvency Act No. 24 of 1936, as amended, that **G. N. C. Rheeder** and **G. Liebenberg** has agreed to sell the business known as **Trattoria Giovanni Pizzeria** situated at 128 Jan Smuts Avenue, Parkwood, Johannesburg, together with goodwill, stock, fixtures and fittings, thirty days after the date of this notice to **Gavin Grant Sharman** who will trade under the name of **Trattoria Giovanni Pizzeria** for his own benefit.

Gold Estates, P.O. Box 1140, Saxonwold, 2126.

NOTICE OF SALE OF BUSINESS

In terms of Section 34 (1) of the Insolvency Act No. 24 of 1936, **Ropa Caterers (Proprietary) Limited** conducting business under the style of **Roland's Cabin** at Shop 12 El Corro Shopping Centre, 130 Weltevreden Road, Northcliff, is hereby giving notice of its sale and of transfer thirty (30) days after publication hereof to **Interleisure Limited**, who will carry on the said business for its own benefit and account.

Solon Phitidis, Attorney, 7th Floor, 15 Anderson Street, Johannesburg, 2001.

Roodepoort. (2) Jose Felix de Abreu Camara. (3) City Open Market, 16a President Square, Roodepoort. (4) Sale of business. (5) Francisco Paul Jardim & Cesar Rodrigues Jardim. (6)—. (7) J. B. Hugo & Cronje, Posbus 115, Krugerdsorp, 6 Oktober 1987.

VERKOOP VAN HANDELSAAK

Kennis geskied hiermee ingevolge Artikel 34 (1) van die Insolvensiewetnommer 24 van 1936, aan belangstellende partye en krediteure, van die voorneme om die handelsaak, goedere of eiendom wat deel vorm van die handelsaak, te verkoop na 'n tydperk van dertig (30) dae vanaf die laaste publikasie van hierdie advertensie en van aksies, omstandighede of voorwaardes wat betrokke is by handelsake of partye of debiteure, soos hieronder gemeld.

Verkoper: **Michael John Metelerkamp** en **Herold Andre Joubert** h/a **The Heads Restaurant and Curio Shop**, 'n restaurant en curio shop wat bedryf word onder die naam en styl van **The Heads Restaurant and Curio Shop**, The Heads, Knysna.

Koper: **Richard Andrew Sohn** wat optree as Trustee ten behoeve van 'n maatskappy nog opgerig te word.

Dated at Johannesburg this 6th day of October 1987.

Damant Bostock & Co., Second Floor, Prudential Assurance Building, 94 Main Street, Johannesburg, P.O. Box 6200, Johannesburg. Tel.: 832-2121.

SALE OF BUSINESS

Notice is hereby given in terms of Section 34 (1) of the Insolvency Act No. 24 of 1936, as amended, that it is the intention of **Michael John Metelerkamp** and **Herold Andre Joubert**, t/a **The Heads Restaurant and Curio Shop**, a restaurant and curio shop carrying on business under the name and style of **The Heads Restaurant and Curio Shop**, at The Heads, Knysna, to dispose of the said assets and goodwill thereof as from thirty (30) days of last publication hereof, to **Richard Andrew Sohn** acting as Trustee on behalf of a company to be formed, who will thereafter carry on business at the same address for their own benefit and account.

Dated at Johannesburg this 6th day of October 1987.

Damant Bostock & Co., 2nd Floor, Prudential Assurance Building, 94 Main Street, Johannesburg, P.O. Box 6200, Johannesburg. Tel.: 832-2121.

SALE OF BUSINESS

Notice is hereby given in terms of Section 34 (1) of Act 24 of 1936, as amended, that the business carried on by **Jurgens Paashaas** under the name and style of **Molly's** trading as **Randburg Deli** at 13 Metro Centre, Hendrik Verwoerd Drive, Randburg, was on the 2nd day of September 1987, disposed of together with the assets thereof to **Marla Elena Russo Pinto** and **Maria de Lourdes Rozkydal**, as Trustees of a Close Corporation, which will trade as **Loma Continental Coffee Bar CK 87/21250/23**, and will carry on the said business for its sole benefit and account at the same address.

Munro McHarry. Tel.: 789 2000.

Johannesburg. (2) Roy Swemmer. (3) Lucio's Pizzeria, 231 D. F. Malan Drive, Blackheath. (4) Sale. (5) Claudio Emanuele Lionello Merlo. (6)—. (7) Dave Isaacs & Associates, Trust Place, Van Riebeeck Avenue, Edenvale, 5/10/87.

Johannesburg. (2) Drew Henderson. (3) Pizzaghetti Factory, 12 Gleneagles Road, Greenside. (4) Sale. (5) Antonio Jose da Fonseca e Silva. (6)—. (7) Dave Isaacs & Associates, Trust Place, Van Riebeeck Avenue, Edenvale, 5/10/87.

Johannesburg. (2) Neville Frederick Bambury and Ronald Lawrence McMaster. (3) Auto Valet Services, 335 Main Reef Road, Denver. (4) Sale. (5) John McGarry. (6)—. (7) Dave Isaacs & Associates, Trust Place, Van Riebeeck Avenue, Edenvale, 1610, 5/10/87.

Johannesburg. (2) Luis Manuel Goncalves. (3) Gold Fruit Tree, Shop 25, First Avenue, Rosettenville, Johannesburg. (4) Sale of business. (5) George Pondikakis. (6)—. (7) H. W. Chain & Chain, 117 Sivewright Avenue, New Doornfontein, P.O. Box 9729, Johannesburg. Tel.: 402-2070/1/2/3.

KENNISGEWING VAN VERKOOP VAN HANDELAARSBESIGHEID OOREENKOMSTIG ARTIKEL 34 VAN WET 24 VAN 1936

Kennis geskied hiermee ooreenkomstig artikel 34 van Wet No. 24 van 1936, soos gewysig, dat **Pierre Boshof** van voorneme is om die boetiekbesigheid te Grond Vloer, Trust Bank-sentrum, h/v Hillstraat en Oaklaan, Randburg, te verkoop en oor te dra aan **Leonard Gerhardus Albertus Griezel en Maria Magdalena Griezel** wat die besigheid sal voortsit by dieselfde adres en onder die naam van "US 2" vir hulle uitsluitlike voordeel en rekening vanaf die 21ste dag van September 1987.

Gedateer te Randburg op hierdie 2de dag van Oktober 1987.

Van der Westhuizen & De Klerk, Prokureurs van die partye, Posbus 4795, Randburg, 2125. Tel.: 789-1713.

KENNISGEWING VAN VERKOOP VAN BESIGHEID

Kennis word hiermee gegee in terme van Artikel 34 van die Insolvensie Wet, Wet 24 van 1936 (soos gewysig) dat **E. J. K. Lewis en C. A. P. Lewis**, van voorneme is om hul besigheid bekend as **Dual Electronic Alarms & Aircooling (Edms.) Beperk** te 4 Roetsweg, Beyers Park, Boksburg as 'n lopende besigheid met effek 30 (dertig) dae na die laaste publikasie van hierdie kennisgewing te verkoop aan **Ivan Redman Evans** wat daarna die besigheid onder 'n ander naam op dieselfde perseel vir sy eie rekening sal voortsit.

Moodie Moodie & Van Rensburg, Legis Domusgebou, Trichardtsweg, Boksburg.

Pretoria. (2) Nicholas Roussopoulos, Ignatia Roussopoulos, Vassilios Lampropoulos and George Koumoutsaris. (3) Waterglen Multi Save Supermarket, Shop No. 77, Waterglen Park Centre, Louis Botha Avenue, Waterkloof Glen, Pretoria. (4) Dissolution of Partnership. (5) Nicholas Roussopoulos, Ignatia Roussopoulos and George Koumoutsaris. (6)—. (7) P. B. Angelopulo & Co., P.O. Box 589, Pretoria, 0001, 8 October 1987.

Johannesburg. (2) Vassilios Lampropoulos and George Koumoutsaris. (3) Glenanda Multi Save Supermarket, corner Vorster and Le Roux Streets, Glenanda, Johannesburg. (4) Dissolution of Partnership. (5) Vassilios Lampropoulos. (6)—. (7) P. B. Angelopulo & Co., P.O. Box 589, Pretoria, 0001, 8 October 1987.

Rustenburg. (2) James John Sharpe. (3) Sharpe's Pharmacy, Smithstraat 70a, Rustenburg. (4) Verkoop. (5) Theo Young. (6)—. (7) Wilsenach Van Wyk & Vennote, Sanlamsentrum, 1115, Andriessstraat, Pretoria.

Boksburg. (2) Sylvia Mouskides. (3) Cafe and General Dealer, Safeway Supermarket, 34 Bartlett Street, Beyers Park, Boksburg. (4) Sale. (5) Paraskevas Iliopoulos. (6)—. (7) D. Damalis, Attorney, 217 Savelkous Building, 256 Paul Kruger Street, Pretoria.

Northam, District of Thabazimbi. (2) Jose Martins Rodrigues, Alberto de Freitas, Batista da Mata and Manuel Caetano Lucio. (3) Northam Liquor Store, conducted at Shop No. 1, situate on Erf 7, Ruby Street, Northam. (4) Sale, the effective date whereof shall be within 120 days of the 19th day of May 1987 and shall be that day upon which the suspensive conditions contained in the Agreement of Sale shall have been fulfilled. (5) Jose Martins Rodrigues and Manuel Caetano Lucio. (6)—. (7) Friedland Hart & Partners, P.O. Box 1003, Pretoria, 0001, 9 October 1987.

KAAP • CAPE

Port Elizabeth. (2) O. C. Kiessig & Company (Pty) Limited. (3) Westway Hardware and Electrical, 359 Cape Road, Port Elizabeth. (4) Sale. (5) Anthony Millar as trustee for a close corporation to be formed. (6)—. (7) Rushmere Noach & Partners, P.O. Box 100, Port Elizabeth, 6000.

NOTICE OF SALE OF BUSINESS IN TERMS OF SECTION 34

Notice is hereby given that **Tomson Mason**, trading under the name of **West Bank Cash Store**, carrying on business of a General Dealer at 36 Bank Street, West Bank, East London, hereby gives Notice that he intends alienating the said business to **Mr Munsemy Naidu** within 30 (thirty) days of the last date of publication of this Notice.

Dated at East London on this 29th day of September 1987.

Sapire & Robinson, Attorneys for Seller, 2nd Floor, Nedbank Building, Oxford Street, East London.

Riviersonderend. (2) M. A. Oosthuizen. (3) Algemene Handelaarsbesigheid, Stander Supermark, Erf 142, Hoofstraat 21, Riviersonderend. (4) Verkoop. (5) Diederick Johannes Opperman. (6)—. (7) Beneke Kannenberg & Du Bois, Posbus 2, Kerkstraat 73, Robertson, 6705, 30 September 1987.

Clanwilliam. (2) Gesina Johanna de Jongh. (3) Wol-en-Baba Sentrum, Voortrekkerstraat, Citrusdal. (4) Vervreemding. (5) Abraham Izak Tredoux. (6)—. (7) Stone & Bresler, Voortrekkerstraat, Posbus 12, Citrusdal.

Tarkastad. (2) Border Transport (Proprietary) Limited. (3) Border Royal Accommodation Establishment and Off-sales, Murray Street, Tarkastad. (4) Sale—30 days. (5) Larry Clifford Elliott. (6)—. (7) Elliott Brothers, 29 Ebdan Street, P.O. Box 1022, Queenstown.

Cape Town. (2) Peter Robert Spence. (3) Restaurant East 19, 65 Durban Road, Mowbray. (4) Sale. (5) Craig Trevor Smith. (6)—. (7) Julius Buchinsky Organisation (Pty) Ltd, Third Floor, Shell House, 9 Riebeeck Street, Cape Town, 8001, 5 October 1987.

Bellville. (2) Dennis Douglas Benade. (3) Heiwie's Grill, 203 (b) Voortrekker Road, Bellville. (4) Sale. (5)—. (6)—. (7) Coulters Van Gend & Kotze, 40 Burg Street, Cape Town, 8001.

Paarl. (2) Tertius Goosen. (3) Cape to Rio Kafee, Hoofstraat 55, Paarl, 7646. (4) Verkoop van besigheid op 10 September 1987. (5) John Henry Smith Potgieter. (6)—. (7) Basson Steyn & Vennote, Posbus 2538, Paarl, 7646.

Cape Town. (2) Maroulla Pluke. (3) Rhodes Food Fare, 435 Main Road, Observatory, Cape Town. (4) Sale. (5) Renate Helene Dorothea Ingram. (6)—. (7) N. G. Constantinides, Legal Department, Premier Group Centre, P.O. Box 1530, Johannesburg, 2000. Tel.: (011) 446-2001.

Mosselbaai. (2) Elkemanspar BK (CK85/03773/23). (3) Spar Food Market, Grunterstraat 50, Mosselbaai. (4) Verkoop. (5) Erika Supermarket (Eiendoms) Beperk. (6)—. (7) Erasmus & Coetzee, Posbus 1580, Mosselbaai, 1987-10-08.

Woodstock. (2) Victor Egbert Voigts. (3) Zola Liquors, 69/71 Sir Lowry Street, Woodstock. (4) Sale. (5) Daww se Drankwinkel (Pty) Limited. (6) Diamond's Bottle Store, 69/71 Sir Lowry Street, Woodstock. (7) Balsillie, Watermeyer & Cawood, 1st Floor, Coronation Arcade, 32 Kruskal Avenue, Bellville.

East London. (2) Johanna Elizabeth Button. (3) Gonubie Mouth Tearoom, Shop 1 Commerce Centre, Gonubie, District of East London. (4) Sale. (5) Ronald Bennion. (6)—. (7) J. A. Yazbek & Co, 1st Floor Sterling House, 24 Gladstone Street, East London, 5201.

Cape Town. (2) S. A. Surface Coatings (Pty) Limited. (3) S. A. Surface Coatings (Pty) Limited, 9 Upper Camp Street, Cape Town. (4) Sale of business. (5) Cumfy Motors (Pty) Limited. (6)—. (7) c/o Abrahams and Gross, P.O. Box 1661, Cape Town.

NATAL

SALE OF BUSINESS

Notice is hereby given in terms of section 34 (1) of the Insolvency Act, 24 of 1936 that **Donald Patrick Dakers** carrying on business as **Domicos Coffee Shop** at Shop 32 Sanlam Center Winklespruit, intend/s to dispose of the said business from 1st November 1987 or intend/s to dispose of the said business after a period of thirty (30) days from the last publication of this notice to **Dennis Gerald Klopper** who will thereafter carry on business for his own account as **Domicos Coffee Shop**, Shop 32, Sanlam Centre, Winklespruit.

Dated at Amanzimtoti this 1st day of October 1987.

Dennis Gerald Klopper, 2 Folwell Road, Warner Beach, 4125.

Pietermaritzburg. (2) Ronald James Glaister. (3) Ronald James Glaister trading as Forsyth & Glaister Plumbing, 105 Victoria Road, Pietermaritzburg. (4) Sale of business. (5) John Oxley. (6)—. (7) Venn, Nemeth & Heart, 281 Pietermaritz Street, Pietermaritzburg.

Durban. (2) Panayiotis Tsezentis. (3) C J's Tobacconist & Candies, 6 Mercury Lane, Durban. (4) Sale—1/9/87. (5) Govindsamy Chetty. (6)—. (7) 11 Juba Place, Reservoir Hills, Durban, 4091.

Durban. (2) Western Sales Corporation (Pty) Ltd. (3) Quik Maid, Alert House, 49 Clark Road, Durban. (4) Sale. (5) Alec George Freeman. (6)—. (7) Western Sales Corporation (Pty) Ltd, Alert House, 49 Clark Road, Durban.

Durban. (2) Martinho Teixeira. (3) Enterprise Fresh Fish and Delicacies, Stores 7 and 8, City Market, Warrick Avenue, Durban. (4) Sale. (5) Gabriel Gomes Pequenezza. (6)—. (7) A. M. C. de Jager, Attorney, 302 Denor House, 356 Smith Street, Durban, 4001.

Amanzimtoti. (2) Charles Frederick Segal. (3) Toti Health Studio, Third Floor, Lagoon Centre, Bjoeseth Crescent, Amanzimtoti. (4) Change of ownership. (5) Steven David Tarpey. (6)—. (7) Steven David Tarpey, Third Floor, Lagoon Centre, Bjoeseth Crescent, Amanzimtoti.

Durban. (2) Jacobus Petrus Mynhardt, Gert Hendrik Mynhardt and Jacoba Johann Mynhardt. (3) Mynhardt Engineering, 21 Dudley Street, Jacobs. (4) Sale—18 September 1987. (5) John Colin Thomas Stovold and Edgar Norman Grose. (6)—. (7) Brivik & Associates, Suite 521, West Walk, Smith Street, Durban.

VERKOOP VAN BESIGHEID

Kragtens Artikel 34 (1) van die Insolvensiewet No. 24 van 1936, soos gewysig, gee **George David Hurle Hill and Majorie Hill** wat besigheid dryf onder die saaknaam van **Headlines Hair Studio** te Santam Sentrum, Allenstraat, Newcastle, hiermee kennis van die verkoop van bogenoemde besigheid en bates en oordrag binne 30 (dertig) dae na publikasie hiervan aan **Patricia Fay Marchetti and William Richard de Swardt**.

Gedateer te Newcastle hierdie 27ste dag van Augustus 1987.

M. L. Hopkins en Kie, Kamer No. 13, S A Perm Arkade, Scottstraat 58, Posbus 3108, Newcastle, 2940.

SALE OF BUSINESS

Notice is hereby given in terms of Section 34 (1) of the Insolvency Act, as amended, the business known as **Headlines Hair Studio** which is at present situate at Santam Centre, Allen Street, Newcastle, has been sold by **George David Hurle Hill and Majorie Hill** to **Patricia Fay Marchetti and William Richard de Swardt** and the assets in the abovementioned business will be transferred to the said **Patricia Fay Marchetti and William Richard de Swardt** thirty (30) days after the last publication hereof.

Dated at Newcastle this 27th day of August 1987.

M. L. Hopkins & Company, Office No. 12, Upper Ground Floor, S A Perm Arcade, 58 Scott Street, P.O. Box 3108, Newcastle.

ORANJE-VRYSTAAT • ORANGE FREE STATE

Parys. (2) Henry John Verster. (3) Nevada Padkafee, Heapstraat 15, Parys. (4) Verkoop van besigheid. (5) Nicolaas Johannes Ras Botha, Heapstraat 15, Parys. (6)—. (7) B. J. van de Vyver, Van Wyk & Kriek, Posbus 256, Parys.

Clocoian. (2) Hendrikus Willem Morkel. (3) Hi-Speed Take Aways, President Brandstraat 1, Clocolan. (4) Verkoop. (5) John Domingos dos Santos en Gabriel Domingos dos Santos. (6)—. (7) Hoffmann & Marais, President C. R. Swartstraat 39, Posbus 78, Reitz, 23 September 1987.

KENNISGEWING IN TERME VAN ARTIKEL 34 (1) VAN WET No. 24 VAN 1936

Kennis geskied hiermee dat **Kobus Groenewald** van voornemens is om die saak bekend as **Vierfontein Kontanhandelaars** te vervreem aan **Leonard Francois Taljaard**, welke saak bedryf word vanaf Sekere Gedeelte van die plaas Groenfontein, distrik Viljoenskroon.

Richter, Els & Hill, Prokureurs vir die Partye, Voortrekkerplein, Posbus 20, Viljoenskroon, 9520.

NOTICE IN TERMS OF SECTION 34 (1) OF ACT No. 24 OF 1936

Notice is hereby given that **Kobus Groenewald** intends alienating the business known as **Vierfontein Kontanhandelaars** to **Leonard Francois Taljaard**, being conducted on a Portion of the farm Groenfontein, District of Viljoenskroon.

Richter, Els & Hill, Attorneys for the Parties, Voortrekker Square, P.O. Box 20, Viljoenskroon, 9520.

MAATSKAPPYKENNISGEWINGS • COMPANY NOTICES

TRANSVAAL

SUID-AFRIKAANSE RESERWEBANK

Kennis geskied hiermee dat die Direksie van die Suid-Afrikaanse Reserwebank 'n tussentydse dividend van vyf persent verklaar het vir die ses maande geëindig 30 September 1987.

Die dividendbewyse sal op 13 November 1987 te Pretoria gepos word aan persone wat by sluiting van sake op 30 Oktober 1987 in die boeke van die Bank geregistreer is.

Op las van die Direksie.—C. J. Swanepoel, Sekretaris, Pretoria, 1 Oktober 1987.

SOUTH AFRICAN RESERVE BANK

Notice is hereby given that the Board of the South African Reserve Bank have declared an interim dividend of five per cent for the six months ended 30 September 1987.

The dividend warrants will be posted at Pretoria on 13 November 1987, to persons registered in the books of the Bank at the close of business on 30 October 1987.

By Order of the Board.—C. J. Swanepoel, Secretary, Pretoria, 1 October 1987.

RANDWATERRAAD

SLUITING VAN EFFEKTEREGISTERS

Kennis geskied hiermee dat die nominale registers en oordragregisters van die ondervermelde geregistreerde effekte vanaf 1 tot 30 November 1987 beide dae inbegrepe, gesluit sal wees, en dat die rente op 1 Desember 1987 betaalbaar, aan effektehouers wat op die sluitingsdatum van die registers geregistreer is, betaal sal word:

12,5 %—1997 (Lening 54).

12,5 %—1997 (Lening 55).

A. J. de Witt, Sekretaris, Fraserstraat 3, Posbus 1127, Johannesburg. (Kennisgewing No. 2202.)

RAND WATER BOARD

CLOSING OF STOCKS REGISTERS

Notice is hereby given that the nominal registers and the transfer registers of the undermentioned registered stock will be closed from 1st to 30th November 1987 both days inclusive, and that the interest payable on 1st December 1987 will be paid to the stockholders registered at the date of closing of registers:

12,5 %—1997 (Loan 54).

12,5 %—1997 (Loan 55).

A. J. de Witt, Secretary, 3 Fraser Street, P.O. Box 1127, Johannesburg. (Notice No. 2202.)

ONDERLINGE VERSEKERINGSGENOOTSKAP AVBOB

KENNISGEWING AAN LEDE

ALGEMENE VERGADERING

Hiermee word kennis gegee dat die ses-en-dertigste algemene vergadering gehou sal word op Vrydag 20 November 1987 om 10h00 in die gebou van die Genootskap, Prinseparklaan 216, Pretoria.

Die volgende sake sal behandel word:

1. Verslag van die direkteure en van die ouditeure en die finansiële jaarstate vir die tydperk geëindig 30 Junie 1987.
2. Verkiesing van direkteure.
3. Vergoeding van direkteure.
4. Verkiesing van ouditeure.
5. Vergoeding van ouditeure.

J. J. F. Nel, Sekretaris, Onderlinge Versekeringsgenootskap AVBOB, Prinsesparklaan 216, Pretoria, 16 Oktober 1987.

AVBOB MUTUAL ASSURANCE SOCIETY

NOTICE TO MEMBERS

Notice is hereby given that the Thirty Sixth General Meeting of Members will be held in the Society's Building, 216 Prince's Park Avenue, Pretoria, on Friday, 20 November 1987, at 10h00.

The following business will be considered:

1. The reports of the directors and auditors, and the annual financial statements for the period ended 30 June 1987.
2. Election of directors.
3. The remuneration of the directors.
4. Election of auditors.
5. The remuneration of the auditors.

J. J. F. Nel, Secretary, AVBOB Mutual Assurance Society, 216 Prince's Park Avenue, Pretoria, 16 October 1987.

S. WEINSTEIN FAMILY HOLDINGS (PTY) LIMITED

(In liquidation)

MASTER'S REFERENCE No.: T2294/87

I hereby give notice of the voluntary winding-up of the above-mentioned Company, which is to be published in the *Government Gazette* in terms of Section 349 (b) of the Companies Act 1973, as amended.

Resolved:

- a. That the Company be wound up in terms of a members voluntary winding-up in accordance with the provisions of the Companies Act 1973, as amended, Section 349 (b).
- b. That in terms of Section 422 of the Companies Act 1973, as amended, the liquidator be authorised, on completion of the liquidation and dissolution of the Company, to destroy the books and records of the Company.
- c. That the liquidator be exempted from furnishing security.

Neville John Jessop, Liquidator.

Golden Trust Services (Pty) Limited, P.O. Box 9460, Johannesburg, 8/10/87.

THE PROPERTY GROUP OF SOUTH AFRICA LIMITED**Reg. No. 83/08037/06**

(Incorporated in the Republic of South Africa)

DECLARATION OF DIVIDEND

Notice is hereby given that Ordinary Dividend No. 5 of 4 cents per share has been declared payable to holders registered in the books of the company at the close of business on 16 October 1987.

For this purpose, the Ordinary Share Register of the company will be closed from 17 October 1987 to 24 October 1987 both days inclusive.

Dividend warrants will be posted to shareholders on or about 2 November 1987.

Non-Resident Shareholders' Tax will be deducted from the dividends of Shareholders whose registered addresses are outside the Republic of South Africa.

By Order of the Board.—S. Brodovsky, Secretary.

Corbank Registrars Limited, P.O. Box 1053, Johannesburg, 2000, 5/10/87.

LONG DISTANCE LIMITED**Reg. No. 81/06368/06**

(Incorporated in the Republic of South Africa)

DECLARATION OF DIVIDEND

Notice is hereby given that Ordinary Dividend No. 1 of 1 cent per share has been declared payable to holders registered in the books of the company at the close of business on 23 October 1987.

For this purpose, the Ordinary Share Register of the company will be closed from 24 October 1987 to 1 November 1987 both days inclusive.

Dividend warrants will be posted to shareholders on or about 12 November 1987.

Non-Resident Shareholders' Tax will be deducted from the dividends of Shareholders whose registered addresses are outside the Republic of South Africa.

By Order of the Board.—A. F. Pretorius, Secretary.

Corbank Registrars Limited, P.O. Box 1053, Johannesburg, 2000, 5/10/87.

RETCO LIMITED**Reg. No. 68/01976/06**

(Incorporated in the Republic of South Africa)

DECLARATION OF DIVIDEND

Notice is hereby given that Ordinary Dividend No. 19 of 2 cents per share has been declared payable to holders registered in the books of the company at the close of business on 16 October 1987.

For this purpose, the Ordinary Share Register of the company will be closed from 17 October 1987 to 24 October 1987 both days inclusive.

Dividend warrants will be posted to shareholders on or about 2 November 1987.

Non-Resident Shareholders' Tax will be deducted from the dividends of Shareholders whose registered addresses are outside the Republic of South Africa.

By Order of the Board.—S. Brodovsky, Secretary.

Corbank Registrars Limited, P.O. Box 1053, Johannesburg, 2000, 5/10/87.

WINDSOR ONE-SIX-TWO (PTY) LTD

(In members voluntary winding-up)

Master's Reference No. T467/87/7B

Pursuant to Section 406 (3) of the Companies Act of 1973, notice is hereby given that the First and Final Liquidation and Distribution Account in the above-mentioned estate, will lie open for creditors inspection at the offices of the Master of the Supreme Court, Pretoria, and at the Magistrate, Kempton Park for a period of 15 (fifteen) days from 16 October 1987 to 30 October 1987—A. M. Serman, c/o A. M. Serman and Partners, P.O. Box 385, Kempton Park. Telephone 970-1030.

ANGLO-TRANVAAL COLLIERIES, LIMITED**Reg. No. 05/08294/06****CLOSING OF TRANSFER BOOKS AND REGISTERS OF MEMBERS**

Notice is hereby given that the transfer books and registers of members will be closed from 31 October to 6 November 1987, both days inclusive.

By Order of the Board.—C. H. Williams, per Anglovaal Limited, Secretaries, Johannesburg, 12 October 1987.

Advertiser and registered office: Anglo-Transvaal Collieries Limited, Anglovaal House, 56 Main Street, Johannesburg. DvdL/ai.

BENSONAR INVESTMENTS (PROPRIETARY) LIMITED

('the Company')

NOTICE OF RESOLUTION TO WIND-UP VOLUNTARILY

Notice is hereby given pursuant to Section 356 (2) (b) of the Companies Act 1973 as amended that at a general meeting of the shareholders of the Company, held at Johannesburg on 19 August 1987 the following special resolutions were adopted:

1. That the Company be voluntarily wound-up in terms of Section 349 (b) of the Companies Act 1973 (as amended).

2. That **Ian Graham Shapiro** be and is hereby appointed liquidator of the Company in terms of Section 375 (5) (b) of the Companies Act 1973 as amended, subject to the Master's approval.
3. That the liquidator be exempt from the obligations to provide security in terms of Section 375 (1) of the Companies Act 1973 as amended for the due performance of his duties.
4. That the liquidator be authorised to destroy the books and records of the Company on completion of the liquidation.
5. That the remuneration of the nominated liquidator be determined by the Company in general meeting.

Dated at Johannesburg on this the 19th day of August 1987.

Ian Graham Shapiro, c/o Moss-Morris Mendelow Browde, 8th Floor, The Inner Court, 74 Kerk Street, Johannesburg.

GENERAL OPTICAL COMPANY LIMITED

DIVIDEND No. 46

CLOSURE OF REGISTER OF MEMBERS

COMPANY NOTICE

DECLARATION OF DIVIDEND AND CLOSURE OF REGISTER

Notice is hereby given that Final Dividend No. 46 of 21 cents will be paid on 7 December 1987 to members registered in the books of the company at the close of business on 13 November 1987.

For the purpose of the Annual General Meeting which is to be held on 19 November 1987, the Register of Members will be closed from 14 to 19 November 1987, both dates inclusive.

By order of the Board: E. S. Godfrey, Secretary.

KAAP • CAPE

GUBB & INGGS LIMITED

(Incorporated in the Republic of South Africa)

SHARE AND TRANSFER REGISTER

The Transfer Register and Register of Members will be closed from 6 November to 18 November 1987, both days inclusive, for the purpose of compiling the lists of shareholders entitled to Final Dividend No. 83.

By Order of the Board.—H. N. Bonner, Secretary, Hendrik van Eck Drive, P.O. Box 23, Uitenhage, 6230.

BURLINGTON INDUSTRIES LIMITED

NOTICE OF PREFERENCE DIVIDEND No. 83

Reg. No. 05/21549/86

Notice is hereby given to Shareholders that a Preference Dividend in respect of the six months ending 30th September 1987 at the rate of 6 per cent per annum (equivalent to 6 cents per share), has been declared payable on the 31st October 1987 to all Preference Shareholders registered in the books of the Company at the close of the business on the 18th October 1987.

The Preference Transfer Register and the Register of Members will be closed from the 19th October to the 25th October 1987 both days inclusive.

By Order of the Board.—R. D. Hugo, Secretary, Transfer Office, 9 Hopkins Street, Salt River, 7925, 22nd September 1987.

CLEGHORN & HARRIS LIMITED

(Incorporated in the Republic of South Africa)

DECLARATION OF DIVIDEND

Notice is hereby given that a Final Dividend of 25 cents (twenty five cents) per share has been declared on Ordinary Shares and will be paid on 2 November 1987 to shareholders registered in the books of the Company at the close of business on 24 October 1987.

The Ordinary Share Register of the Company will be closed from 26 October 1987 to 2 November 1987, both days inclusive.

In terms of the Republic of South Africa Income Tax Act 1961 (as amended) Non-Resident Shareholders' Tax of 15% will be deducted from dividends payable to Non-Resident Shareholders.

By Order of the Board.—J. A. Simpson, Secretary, Cleghorn & Harris Ltd, 22 Station Road, Rondebosch, 7700, 5 October 1987.

NATAL

TAMBOURINE DOVE (PROPRIETARY) LIMITED

Notice is hereby given that the following Resolutions were passed pursuant to Section 349 (b) of the Companies Act, 1973, as amended, at a General Meeting of Shareholders of the company held for that purpose at Suite 1922, 320 West Street, Durban on 9th September 1987.

1. That the company be liquidated by process of a members' voluntary winding-up in terms of Section 350 of the Companies Act, 1973, as amended, and that **Alex Sinclair Moodie** be and he is hereby nominated Liquidator of the company.

2. That the Liquidator's remuneration be agreed between the Directors and the Liquidator provided it shall not exceed the tariff laid down in the Companies Act, 1973, as amended.

3. That in terms of Section 375 (1) of the Companies Act, 1973, as amended, it shall not be necessary for the Liquidator to furnish security for the due performance of his duties.

4. That upon the final dissolution of the company the Liquidator be and he is hereby authorised and directed to destroy the books and records of the company or to procure their destruction in terms of Section 422 (1) (b) of the Companies Act, 1973, as amended.

R. D. S. Quintas.

MECHAWELD MARINE (PROPRIETARY) LIMITED

Notice is hereby given that the following Resolutions were passed pursuant to Section 349 (b) of the Companies Act, 1973, as amended, at a General Meeting of Shareholders of the company held for that purpose at Suite 1922, 320 West Street, Durban on 9th September 1987.

1. That the company be liquidated by process of a members' voluntary winding-up in terms of Section 350 of the Companies Act, 1973, as amended, and that Alex Sinclair Moodie be and he is hereby nominated Liquidator of the company.
2. That the Liquidator's remuneration be agreed between the Directors and the Liquidator provided it shall not exceed the tariff laid down in the Companies Act, 1973, as amended.
3. That in terms of Section 375 (1) of the Companies Act, 1973, as amended, it shall not be necessary for the Liquidator to furnish security for the due performance of his duties.
4. That upon the final dissolution of the company the Liquidator be and he is hereby authorised and directed to destroy the books and records of the company or to procure their destruction in terms of Section 422 (1) (b) of the Companies Act, 1973, as amended.

R. D. S. Quintas.

HOSPITALITY PROPERTIES (PROPRIETARY) LIMITED

(In provisional liquidation)

MASTER'S REF. No. N13/87

NOTICE CONVENING MEETING OF CREDITORS IN ACCORDANCE WITH SECTION 311 OF THE COMPANIES ACT 61 OF 1973, AS AMENDED

1. Notice is given in terms of an Order dated 6th October 1987 of the Supreme Court of South Africa (Natal Provincial Division) ("the Court"), that **Mark William Lynn**, be and is hereby authorised to convene separate meetings in terms of Section 311 (1) of the Companies Act, No. 61 of 1973, as amended ("the Act") of:

- 1.1 Secured creditors.
- 1.2 Preferent creditors.
- 1.3 Concurrent creditors.

of **Hospitality Properties (Proprietary) Limited** ("the Company"), for the purpose of considering and, if though fit, of accepting, with or without modification, an Offer of Compromise proposed by the Company between the Company and its creditors.

2. The meetings will be held in the Boardroom of E. R. Browne Incorporated, 10th Floor, United Building, 194 Longmarket Street, Pietermaritzburg on the 30th October 1987. The meetings will be held on that date at 15h00, 15h15 and 15h30 respectively.

3. **Lloyd Edward Spendiff** shall act as Chairman at each of the said meetings.

4. A copy of this Order, in the terms of the said Offer of Compromise, a list of creditors of the Company and a Statement of the assets of the Company with their estimated values may be inspected during business hours at any time prior to the said meetings at the office of **E. R. Browne Incorporated**, 10th Floor, United Building, 194 Longmarket Street, Pietermaritzburg, Natal.

5. A copy of the Statement required by Section 312 (1) and (2) of the Act may be obtained by any creditor entitled to attend the said meetings at the time and place mentioned in paragraph 2 above, free of charge, on written application to The Liquidator, Hospitality Properties, E. R. Browne Incorporated, 10th Floor, United Building, 194 Longmarke Street, Pietermaritzburg, 3201.

6. In the event of the said Offer of Compromise being agreed to by the majorities required in terms of Section 311 (2) of the said Act, application will be made to the Court on Friday, 13th November 1987, at 09h30, or as soon thereafter as the matter can be heard, for the sanction by the Court of the said Scheme of Arrangement, as amended, and an Order that the provisional liquidation be discharged.

7. The Chairman of each of the said meetings shall report the result thereof to the Court by Affidavit.

8. In the event of the Applicant making application for the sanction of the Court of the said Arrangement, he may so apply on the papers filed in this application, duly supplemented insofar as it may be necessary.

9. A creditor intending to vote at any of the said meetings in person or by proxy must lodge with the Chairman of such meeting at the aforesaid offices of **E. R. Browne Incorporated** not later than forty eight (48) hours before the time at which it is to be held, a written statement of the amount of its claim and as to whether it is secured, preferent or concurrent.

10. A copy of the Report to the Court of the chairman of each meeting will be available to any creditor on request with effect from the 10th November 1987.

M. W. Lynn, the liquidator, Hospitality Properties (Pty) Ltd, E. R. Browne Incorporated, 10th Floor, United Building, 194 Longmarket Street, Pietermaritzburg.

**LIKWIDATEURS EN ANDER AANGESTELDES SE KENNISGEWINGS
LIQUIDATORS' AND OTHER APPOINTEES' NOTICES**

Kennisgewings deur likwidateurs en ander aangesteldes soos eksekuteurs, geregtelike bestuurders, trustees, kurators of voogde, van aanstellings, vergaderings, rekeninge, eise, verlof, vrystellings, ens.

Notices by liquidators and other appointees such as executors, judicial managers, trustees, curators or tutors, of appointments, meetings, accounts, claims, leave of absence, releases, etc.

KAAP • CAPE**ADA SHAPIRO & COMPANY (PROPRIETARY) LIMITED**

No. C402/87

(IN VOLUNTARY LIQUIDATION)

Notice is hereby given that **Claude William Kirkman** has been appointed Liquidator of Ada Shapiro & Company (Proprietary) Limited. Sandak-Lewin, Kirkman & Noland, 10th Floor, Southern Life Centre, 2 St George's Street, Cape Town, 8001.

ORDERS VAN DIE HOF • ORDERS OF THE COURT

Transvaalse Provinsiale Afdeling, Pretoria
Transvaal Provincial Division, Pretoria

Saak 12615/87

IN DIE HOOGGEREGSHOF VAN SUID-AFRIKA
 (Transvaalse Provinsiale Afdeling)

Pretoria, die 30ste dag van September 1987 voor Sy Edele Regter Esselen

In die saak tussen **Die Transvaalse Raad vir die Ontwikkeling van Buitestedelike Gebiede**, Applikant, en **Locarno Investments (Pty) Ltd, No. 51/01404/07**, Respondent

Na aanhoor van die advokaat namens die applikant en na deurlees van die Kennisgewing van Mosie en ander stukke geliasseer:

Word Gelas:

1. Dat 'n bevel *nisi* uitgereik word wat alle belanghebbende persone oproep om redes, indien enige, voor hierdie Hof aan te voer op 10 November 1987 om 10h00 waarom 'n bevel met die volgende terme nie gemaak moet word nie:

a. Dat die registrasie van die maatskappy **Locarno Investments (Pty) Ltd, No. 51/01404/07** (hierna "die Maatskappy" genoem) herstel word op die Register van Maatskappye ingevolge Artikel 73 (6) van Wet 61 van 1973 soos gewysig (hierna "die Wet" genoem).

b. Dat die volgende bate(s) van die Maatskappy verklaar word nie langer *bona vacantia* te wees nie:

Erf 101 geleë in dorp Pendale Landbouhoewes: Groot 1,7131 hektaar; Gehou kragtens Akte van Transport No. T484/1953.

c. Dat die Maatskappy gelas word om:

i. Vorm CM 22, CM 29, en CM 31 ingevolge Artikels 170, 216 en 276 van die Wet in te dien binne 30 (dertig) dae na datum van verlening van hierdie bevel.

ii. Die bewys van betaling van die jaargeld vir die jare 1965 tot 1974 ingevolge Artikel 174 (4) van die Wet op die voorgeskrewe vorm in te dien binne 30 (dertig) dae na datum van verlening van hierdie bevel.

d. Dat by die versuim van die Maatskappy om te voldoen aan die bepaling van paragraaf c. hierbo, die adjunk-balju van Pretoria gemagtig word om die vorms namens en ten behoeve van die Maatskappy te onderteken en in te dien.

e. Dat die Maatskappy gelas word om die koste van hierdie aansoek te betaal.

2. a. Dat hierdie bevel beteken word op die Registrateur van Maatskappy, die Registrateur van Aktes, die Minister van Finansies, die Minister van Openbare Werke en Grondsake, Max Katzoff en Douglas Isaac Espinosa Schulman.

b. Gesien in die lig van die feit dat die twee direkteure, Max Katzoff en Douglas Isaac Espinosa Schulman nie opgespoor kan word nie, betekening op hulle voldoende geskied by wyse van publikasie soos uiteengesit in paragraaf 3.

3. Dat hierdie bevel een maal gepubliseer word in Engels en in Afrikaans in die *Staatskoerant* asook een maal in Afrikaans in "*Die Beeld*" en een maal in Engels in "*The Star*" synde nuusblaai wat in Transvaal sirkuleer.

Deur die Hof.—M. S. Hansen, Griffier.

3 Griffiths. eb.

Case 12615/87

IN THE SUPREME COURT OF SOUTH AFRICA
 (Transvaal Provincial Division)

Pretoria, the 29th day of September 1987 before the Honourable Mr Justice Esselen

In the matter between **The Transvaal Board for the Development of Peri-Urban Areas**, Applicant, and **Locarno Investments (Pty) Ltd, No. 51/01404/07**, Respondent

Having heard Counsel for the applicant and having read the Notice of Motion and other documents filed:

It is Ordered:

1. That a rule *nisi* is hereby issued calling upon all persons concerned to appear and show cause, if any, to this court on the 10th of November 1987 at 10h00 why an order should not be made in the following terms:

a. That the registration of the company **Locarno Investments (Pty) Ltd No. 51/1404/07** (hereinafter referred to as "the Company") is restored to the company register in terms of Section 73 (6) of Act 61 of 1973 as amended (hereinafter referred to as "the Act").

b. That the following assets of the Company are declared to be no longer *bona vacantia*:

Erf 101 situated in the town Pendale: Measuring 1,7131 hectare: Held by deed of transfer No. T484/1953.

c. That the Company is ordered to:

i. Submit Forms CM 22, CM 29 and CM 31 in terms of Section 170, 216 and 276 of the Act, within 30 (thirty) days after date of this order.

ii. Submit proof of payment of the annual duty for the years 1974–1976 in terms of Section 174 (4) of the Act on the prescribed form within 30 (thirty) days after date of this order.

d. That should the Company neglect to comply with the provisions of paragraph c. above, the deputy sheriff of Pretoria be and is authorised to sign and submit the forms on behalf of the Company.

e. That the Company pays the costs of this application.

2. a. That this Rule *nisi* is to be served on the Registrar of Companies, the Registrar of Deeds, the Minister of Finance, the Minister of Public Works and Land Affairs, Max Katzoff and Douglas Isaac Espinosa Schulman.

b. Seeing in the light of the fact that the two directors, Max Katzoff and Douglas Isaac Espinosa Schulman have been unable to locate, that this rule *nisi* be served on them as set out in paragraph 3 hereof.

3. That this rule *nisi* is to be published once in English and in Afrikaans in the *Government Gazette* as well as once in Afrikaans in "*The Beeld*" and once in English in "*The Star*" being the newspapers circulating in the Transvaal.

By the Court.—M. S. Hansen, Registrar.

3 Griffiths. /eb.

ORDERS VAN DIE HOF (vervolg) • ORDERS OF THE COURT (continued)

Saak 15341/87

IN DIE HOOGGEREGSHOF VAN SUID-AFRIKA
(Transvaalse Provinsiale Afdeling)

Pretoria, die 24ste dag van September 1987 voor Sy Edele Regter Curlewis

In die saak tussen **Bob Ian Fitzgerald**, Applikant, en **L. P. C. Waterproofing (Edms) Bpk**, 1ste Vloer, Prentice Place, D. F. Malan Rylaan, Northcliff, Johannesburg, Respondent

Na aanhoor van die advokaat namens die applikant en na deurlees van die stukke geliasseer:

Word Gelas:

1. Dat die bogemelde Respondent maatskappy hierby in voorlopige likwidasië geplaas word.
2. Dat 'n bevel *nisi* hierby uitgereik word wat alle belanghebbende persone oproep om redes, indien enige, voor hierdie Hof aan te voer om 10h00 op die 3de November 1987 waarom die Respondent maatskappy nie onder finale likwidasië geplaas sal word nie.
3. Dat betekening van hierdie bevel *nisi* geskied aan die Respondent maatskappy by sy geregistreerde kantoor, aan alle bekende skuldeisers van die Respondent maatskappy per aangetekende pos en onverwyld gepubliseer word in elk van die *Staatskoerant* en die *Beeld* Nuusblad.

Let Wel: Enige krediteur wat verdere inligting rakende hierdie aangeleentheid verlang moet met die prokureurs aan die einde van hierdie bevel in verbinding tree, en/of met die Meester van die Hooggeregshof, Privaatsak X60, Pretoria, 0001, Tel. No. 28-6521.

Deur die Hof.—Griffier.

152 Botha, Posbus 2345, Pretoria. /mb.

Saak 9748/87

IN DIE HOOGGEREGSHOF VAN SUID-AFRIKA
(Transvaalse Provinsiale Afdeling)

Pretoria, die 6de dag van Oktober 1987 voor Sy Edele Regter McCreath

In die aansoek tussen **Josua Johan Andries Roux**, Applikant, en **Aldaleen Beleggings (Edms) Beperk**, Respondent

Na aanhoor van die Advokaat namens die applikant en na deurlees van die stukke geliasseer:

Word Gelas:

1. Dat die bogemelde Respondent maatskappy hierby in voorlopige likwidasië geplaas word.
 2. Dat 'n bevel *nisi* hierby uitgereik word wat alle belanghebbende persone oproep om redes, indien enige, voor hierdie Hof aan te voer om 10h00 op die 3de November 1987, waarom die Respondent maatskappy nie onder finale likwidasië geplaas sal word nie.
 3. Dat betekening van hierdie bevel *nisi* geskied aan die Respondent maatskappy by sy geregistreerde kantoor.
- Op Las van die Hof.—F. J. van Tonder, Applikant se prokureur, Heatherlandsgebou 107, Paul Krugerstraat 922, Mayville, Pretoria.

Saak 'X'

IN DIE HOOGGEREGSHOF VAN SUID-AFRIKA
(Transvaalse Provinsiale Afdeling)

Pretoria, die 29ste dag van September 1987 voor Sy Edele Regter Esselen

In die *ex parte* aansoek van **Sergio Cantale**, 1ste Applikant, en **Maria Cornelia Elizabeth Cantale**, 2de Applikant

Na aanhoor van advokaat vir die applikante en na deurlees van die stukke hierin word beveel dat:

Word Gelas:

1. 'n Bevel *Nisi* uitgereik word waarby die krediteure van die applikante 'n lys waarvan hierby aangeheg is as Bylae "A", asook enige ander krediteur, redes mag aanvoer op die 3de dag van November 1987 in bogenoemde Hof waarom dit nie beveel sal word:
 - 1.1 dat verlot verleen word aan applikante ingevolge artikel 21 (1) van Wet 88 van 1984 om die huweliksgoederebedeling tussen hulle te wysig deur die aangaan en registrasie van 'n notariële akte, 'n konsep waarvan aangeheg is aan eerste applikante se ondersteunde eedverklaring en gemerk " ", en welke akte, na registrasie daarvan, die huweliksgoederebedeling tussen die partye sal reël;
 - 1.2 dat die Registrateur van Aktes gemagtig word om die genoemde notariële akte te registreer;
 - 1.3 dat hierdie bevel—
 - 1.3.1 sal verval indien die notariële akte nie geregistreer word deur die Registrateur van Aktes binne twee maande nadat hierdie bevel bekragtig is nie; en
 - 1.3.2 nie die regte van enige krediteur van die applikante op datum van registrasie van die akte sal benadeel of beperk nie.
 2. Dat hierdie bevel per geregistreerde pos aan elkeen van die krediteure wie se name op Bylae "A" verskyn beteken word.
 3. Dat hierdie bevel ingeslote Bylae "A" in die *Staatskoerant* gepubliseer word.
- Op Las van die Hof.—GRIFFIER.

AANHANGSEL "A"

Krediteure:

1. Klererekening: Edgars, Kerkstraat, Pretoria;
2. Klererekening: Foschini, hoek van Pretorius- en Andriessstraat;
3. Barclay Card; Eerste Nasionale Bank, Kerkplein, Pretoria;
4. Skoolrekening: Loreto Convent: Queenswood; Christian Boys College Mount Edmund.

ORDERS VAN DIE HOF (vervolg) • ORDERS OF THE COURT (continued)

**Witwatersrandse Plaaslike Afdeling, Johannesburg
Witwatersrand Local Division, Johannesburg**

Case 9383/87

IN THE SUPREME COURT OF SOUTH AFRICA
(Witwatersrand Local Division)

Randburgh, the 29th day of September 1987 before his Worship Mr Justice Bosman

In the matter between **Donald Charles Goschen**, Applicant, and **Keats Meat Products CC**, Respondent

Having heard argument on behalf of Applicant and having read the application and other documents filed of record:

It is Ordered:

1. That the above-mentioned Respondent corporation be and is hereby placed under provisional winding-up in the hands of the Master having jurisdiction in terms of the Close Corporation Act 69 of 1984.
 2. That a Rule *Nisi* do issue calling upon all persons concerned to appear and to show cause, if any, to this Court on the 27th day of October 1987 at 09h00, why the said Respondent corporation should not be placed under final winding-up.
 3. That a copy of the Rule *Nisi* be served upon the Respondent corporation at its registered office and be published forthwith once in the *Government Gazette* and in a Johannesburg daily newspaper.
 4. That a copy of the Rule *Nisi* be served on all known creditors by registered post.
- By Order of the Board.—Ivan Zartz, Attorney for Applicant, 6th Floor, Kine Centre, Commissioner Street, Johannesburg.

Case 19026/87

IN THE SUPREME COURT OF SOUTH AFRICA
(Witwatersrand Local Division)

Johannesburg, the 29th day of September 1987 before the Honourable Mr Justice Weyers

In the matter between **H J Henochsberg Pty Ltd**, Applicant, and **Rodin Tie and Clothing Manufacturers Pty Ltd**, having its registered office at 31 Clovelly Road, Greenside Extension, Johannesburg and having its principal place of business at 3rd Floor, Primet House, 16 Buxton Street, Doornfontein, Johannesburg, Respondent

Having heard Counsel for the Applicant and having read the Application:

It is Ordered:

1. That the above-mentioned Respondent Company be and is hereby placed under provisional winding-up Order in the hands of the Master.
2. That a Rule *Nisi* do issue calling upon all persons concerned to appear and to show cause, if any, to this Court on the 3rd day of November 1987 at 10h00 a.m., why the said Respondent Company should not be placed under final winding-up Order.
3. That a copy of this Rule *Nisi* be served on the Respondent Company at its registered office and be published forthwith once in the *Government Gazette* and in a Johannesburg daily newspaper.
4. Recommending to the Master of the Supreme Court that he appoint a provisional liquidator of the Respondent as soon as possible.
5. Granting in terms of Section 386 (5) of Act No. 61 of 1973 as amended ("the Act") to the provisional liquidator so appointed by the Master to exercise the powers referred to in Section 386 (4) (f) of the Act.

By the Court.—H. van Rensburg, Registrar. /mm.

William Aronsohn & Goodman. Ref. J. Cuzen. Tel.: 339-1857.

Case 15705/87

IN THE SUPREME COURT OF SOUTH AFRICA
(Witwatersrand Local Division)

Johannesburg, the 11th day of August 1987 before the Honourable Mr Justice Preiss

In the matter between **Simon Zaidel**, Applicant, and **Simward Outfitters (Pty) Limited**, having its registered office at Suite 1, Nedbank Corner, Louis Botha Avenue, Bramley, Respondent

Having heard Counsel for the Applicant and having read the application:

It is Ordered:

1. That the above-mentioned Respondent Company be and is hereby placed under provisional winding-up Order in the hands of the Master.
2. That a Rule *Nisi* do issue calling upon all persons concerned to appear and to show cause, if any, to this Court on the 15th day of September 1987 at 10h00 a.m., why the said Respondent Company should not be placed under final winding-up Order.
3. That a copy of this Rule *Nisi* be served on the Respondent Company at its registered office and be published forthwith once in the *Government Gazette* and in the *Star*. Service on Co. at registered address.
4. That a copy of this Rule *Nisi* be served on all known creditors by registered post.

N.B. Any creditor who requires further information regarding this matter should communicate with the attorney/s reflected at the foot of this Order and/or with the Master of the Supreme Court, Private Bag X60, Pretoria, 0001. [Tel.: (012) 28-6521.]

By the Court.—G. A. Engelbrecht, Asst. Registrar. /mm.

Silver Singer Horwitz. Ref.: S1084/13299.

ORDERS VAN DIE HOF (vervolg) • ORDERS OF THE COURT (continued)

Case 15705/87

IN THE SUPREME COURT OF SOUTH AFRICA
(Witwatersrand Local Division)

Johannesburg, the 15th day of September 1987 before the Honourable Mr Justice Smit

In the matter between **Simon Zaidel**, Applicant, and **Simward Outfitters (Pty) Limited**, RespondentUpon the motion of Counsel for the Applicant and upon reading the Rule *Nisi* and provisional winding-up Order issued out of this Court on the 11th day of August 1987:*It is Ordered:*That the return day of the aforesaid Rule *Nisi* be and is hereby extended to the 27th day of October 1987.

By the Court.—D. G. Llewellyn, Asst. Registrar. /hm

Silver Singer Horwitz. Ref.: S1084/13299.

Case 18950/87

IN THE SUPREME COURT OF SOUTH AFRICA
(Witwatersrand Local Division)

Johannesburg, the 23rd day of September 1987 before the Honourable Mr Justice Flemming

In the matter between **Lever Brothers (Pty) Ltd**, Applicant, and **Cosmos Wholesalers and Exporters Pty Limited**, carries on business as wholesalers with its principal place of business at 32 Coppell Road, Alrode South Extension 2, Alberton, and its registered office at care of Geldenhuys and Steyn, 78 Rivonia Road, Sandhurst, Sandton, Respondent

Having heard Counsel for the Applicant and having read the Application:

It is Ordered:

1. That the above-mentioned Respondent Company be and is hereby placed under provisional Winding-up Order in the hands of the Master.
2. That a Rule *Nisi* do issue calling upon all persons concerned to appear and to show cause, if any, to this Court on the 27th day of October 1987 at 10h00 a.m., why the said Respondent Company should not be placed under final winding-up Order.
3. That a copy of this Rule *Nisi* be served on the Respondent Company at its registered office and be published forthwith once in the *Government Gazette* and in a Johannesburg daily newspaper.

By the Court.—D. G. Llewellyn, Registrar. /mm

Moss-Morris Mendelow Browde. Ref. Mr L. Chiat. Tel. 337-2121.

Case 87/18978

IN THE SUPREME COURT OF SOUTH AFRICA
(Witwatersrand Local Division)

Johannesburg, the 29th day of September 1987 before the Honourable Mr Justice Weyers

In the matter between **Pioneer Ready Mixed Concrete (Pty) Ltd**, Applicant, and **Dare Property Holding (Pty) Ltd**, trading as **Dare Manufacturing**, having its registered office at 15 9th Road, Rynfield Agricultural Holdings, Section 1, Benoni, Respondent

Having heard Counsel for the Applicant and having read the Application:

It is Ordered:

1. That the above-mentioned Respondent Company be and is hereby placed under provisional winding-up Order in the hands of the Master.
2. That a Rule *Nisi* do issue calling upon all persons concerned to appear and to show cause, if any, to this Court on the 20th day of October 1987 at 10h00 a.m., why the said Respondent Company should not be placed under final winding-up Order.
3. That a copy of this Rule *Nisi* be served on the Respondent Company at its registered office and be published forthwith once in the *Government Gazette* and in a Johannesburg daily newspaper.

By the Court.—D. G. Llewellyn, Asst. Registrar. /ws.

Taitz & Skikne. Ref. Mr Taitz.

Case 57104/87

IN THE MAGISTRATE'S COURT FOR THE DISTRICT OF JOHANNESBURG HELD AT JOHANNESBURG
(Witwatersrand Local Division)In the matter between **Collective Enterprises**, Applicant, and **Gift Creations CC**, trading as **Wendy's Gifts**, Respondent*It is Ordered:*

1. That the above-mentioned Respondent Close Corporation be and is hereby placed under provisional winding-up in the hands of the Master.
2. That a Rule *Nisi* do issue calling upon all persons concerned to appear and to show cause, if any, to this Court on the 21st day of October, 1987, at 09h00, why the said Respondent Close Corporation should not be placed under final winding-up.
3. That a copy of this Rule *Nisi* be served on the Respondent Close Corporation at its registered office and be published forthwith once in the *Government Gazette* and in a Johannesburg daily newspaper.
4. That the costs of this application be costs in the liquidation of the Respondent Close Corporation.

N.B. Any creditor who requires further information regarding this matter should communicate with the attorneys reflected at the foot of this Order and/or with the Master of the Supreme Court, Private Bag X60, Pretoria, 0001. [Tel.: (012) 28-6521.]

By Order of the Court.—Clerk of the Court.

Salomon-Friedman, Applicant's Attorneys, 1st & 2nd Floors, SFB Chambers, 133 Marshall Street, Johannesburg; P.O. Box 7019. Tel.: 331-0312. Ref.: Mr M. Salomon/jr.

ORDERS VAN DIE HOF (vervolg) • ORDERS OF THE COURT (continued)

Case 18507/87

IN THE SUPREME COURT OF SOUTH AFRICA
(Witwatersrand Local Division)

Johannesburg, the 22nd day of September 1987 before the Honourable Mr Justice Kriegler

In the matter between **Catholic (Proprietary) Limited**, First Applicant, **Anthony Jericevich**, Second Applicant, and **Bakers Fare (Proprietary) Limited**, having its registered office at c/o S. E. Kobrin and Co., 1st Floor, Hiross House, Corner Eileen and Geneva Roads, Blairgowrie, Randburg, Respondent

Having heard Counsel for the applicants and having read the application:

It is Ordered:

1. That the forms and service provided for in the Rules of Court be dispensed with in terms of Rule 6(12)(a).
2. That the above-mentioned respondent company be and is hereby placed under provisional winding up in the hands of the Master.
3. That a Rule *Nisi* do issue calling upon all persons concerned to appear and show cause, if any, to this Court on 3rd day of November 1987 at 10h00, why the said respondent company should not be placed under final winding up.
4. That a copy of this Rule *Nisi* be served on the respondent company at its registered office and be published forthwith once in the *Government Gazette* and in a Johannesburg daily newspaper.

By the Court.—D. G. Llewellyn, Registrar.
Wilks and Polovin. Tel. 23-2726.

Case 59991/87

IN THE MAGISTRATE'S COURT FOR THE DISTRICT OF JOHANNESBURG HELD AT JOHANNESBURG
(Witwatersrand Local Division)

Johannesburg, the 30th day of September 1987 before the Presiding Magistrate

In the *ex parte* application of **D.H.B. Agencies CC**, Applicant

Having heard the Applicant's Attorney of Record and having read the Application:

The Court Grants an Order:

1. That the above-mentioned Applicant be and is hereby placed under Provisional Winding Up in the hands of the Master of the Supreme Court.
2. That a Rule *Nisi* do issue calling upon all persons concerned to appear and to show cause, if any, to this Court on the 30th day of October 1987, at 9 a.m. why the Applicant should not be placed under a final Winding Up.
3. That a copy of this Rule *Nisi* be served on the Applicant at its registered office and be published forthwith once in the *Government Gazette* and in a Johannesburg daily newspaper.
4. That a copy of this Rule *Nisi* be served on all known creditors of the Applicant by prepaid registered mail.
5. That the costs of this Application be costs in the Winding Up.
6. That the Applicant report back to the above Honourable Court by Affidavit prior to the Return Date that it has complied with the contents of paragraphs 3 and 4 above.

N.B. Any creditor who requires further information regarding this matter should communicate with the Attorney reflected on this Order and/or with the Master of the Supreme Court, P.O. Box X60, Pretoria, 0001. [Tel.: (012) 28-6521.]

By the Court.—The Clerk of the Court, Johannesburg.

David Oshry, Applicant's Attorney, Suite 2715, Carlton Centre, Commissioner Street; P.O. Box 78, Johannesburg. Tel. 331-5361. Ref. Mr D. Oshry.

Case 59989/87

IN THE MAGISTRATE'S COURT FOR THE DISTRICT OF JOHANNESBURG HELD AT JOHANNESBURG
(Witwatersrand Local Division)

Johannesburg, the 30th day of September 1987 before the Presiding Magistrate

In the *ex parte* application of **Modern World CC**, Applicant

Having heard the Applicant's Attorney of Record and having read the Application:

The Court Grants an Order:

1. That the above-mentioned Applicant be and is hereby placed under Provisional Winding Up in the hands of the Master of the Supreme Court.
2. That a Rule *Nisi* do issue calling upon all persons concerned to appear and to show cause, if any, to this Court on the 30th day of October 1987, at 9 a.m. why the Applicant should not be placed under a final Winding Up.
3. That a copy of this Rule *Nisi* be served on the Applicant at its registered office and be published forthwith once in the *Government Gazette* and in a Johannesburg daily newspaper.
4. That a copy of this Rule *Nisi* be served on all known creditors of the Applicant by prepaid registered mail.
5. That the costs of this Application be costs in the Winding Up.
6. That the Applicant report back to the above Honourable Court by Affidavit prior to the Return Date that it has complied with the contents of paragraphs 3 and 4 above.

N.B. Any creditor who requires further information regarding this matter should communicate with the Attorney reflected on this Order and/or with the Master of the Supreme Court, P.O. Box X60, Pretoria, 0001. [Tel.: (012) 28-6521.]

By the Court.—The Clerk of the Court, Johannesburg.

David Oshry, Applicant's Attorney, Suite 2715, Carlton Centre, Commissioner Street; P.O. Box 78, Johannesburg. Tel. 331-5361. Ref. Mr D. Oshry.

ORDERS VAN DIE HOF (vervolg) • ORDERS OF THE COURT (continued)

Case 59991/87

IN THE MAGISTRATE'S COURT FOR THE DISTRICT OF JOHANNESBURG HELD AT JOHANNESBURG
(Witwatersrand Local Division)

Johannesburg, the 30th day of September 1987 before the Presiding Magistrate

In the *Ex Parte* Application of D.H.B. Agencies CC, Applicant

Having heard the Applicant's Attorney of Record and having read the Application:

The Court Grants an Order:

1. That the above-mentioned Applicant be and is hereby placed under Provisional Winding Up in the hands of the Master of the Supreme Court.
2. That a Rule *Nisi* do issue calling upon all persons concerned to appear and to show cause, if any, to this Court on the 30th day of October 1987, at 9 a.m. why the Applicant should not be placed under a final Winding Up.
3. That a copy of this Rule *Nisi* be served on the Applicant at its registered office and be published forthwith once in the *Government Gazette* and in a Johannesburg daily newspaper.
4. That a copy of this Rule *Nisi* be served on all known creditors of the Applicant by prepaid registered mail.
5. That the costs of this Application be costs in the Winding Up.
6. That the Applicant report back to the above Honourable Court by Affidavit prior to the Return Date that it has complied with the contents of paragraphs 3 and 4 above.

N.B. Any creditor who requires further information regarding this matter should communicate with the Attorney reflected on this Order and/or with the Master of the Supreme Court, P.O. Box X60, Pretoria, 0001. [Tel.: (012) 28-6521.]

By the Court.—The Clerk of the Court, Registrar.

David Oshry, Applicant's Attorney, Suite 2715, Carlton Centre, Commissioner Street; P.O. Box 78, Johannesburg. Tel. 331-5361. Ref. Mr D. Oshry.

Case 17471/87

IN THE SUPREME COURT OF SOUTH AFRICA
(Witwatersrand Local Division)

Johannesburg, the 15th day of September 1987 before the Honourable Mr Justice Smit

In the matter between Eric Cecil Denis Yoko, Applicant, and S A Tiling Contractors Pty Ltd, having its registered office at Suite 10, Northfield Centre, Northfield Avenue, Glenhazel, Johannesburg, Respondent

Having heard Counsel for the Applicant and having read the application:

It is Ordered:

1. That the above-mentioned Respondent Company be and is hereby placed under provisional winding-up Order in the hands of the Master.
2. That a Rule *Nisi* do issue calling upon all persons concerned to appear and to show cause, if any, to this Court on the 27th day of October 1987 at 10h00 a.m., why the said Respondent Company should not be placed under final winding-up Order.
3. That a copy of this Rule *Nisi* be served on the Respondent Company at its registered office and be published forthwith once in the *Government Gazette* and in a Johannesburg daily newspaper.

By the Court.—D. G. Llewellyn, Registrar. /mm.

Attorney Ivan Morris. Ref. Mr Morris. Tel.: 787-9638.

Case 87/18717

IN THE SUPREME COURT OF SOUTH AFRICA
(Witwatersrand Local Division)

Johannesburg, the 24th day of September 1987 before the Honourable Mr Justice Kriegler

In the matter between Charles Stanhope Courtney-Clarke, Applicant, and Industrial Investments & Development Company (Proprietary) Limited, has its registered office at Plot 7, Merrowlane, Merrowdown, Sandton, Respondent

Having heard Counsel for the Applicant and having read the Application:

It is Ordered:

1. That the above-mentioned Respondent Company be and is hereby placed under provisional winding-up Order in the hands of the Master.
2. That a Rule *Nisi* do issue calling upon all persons concerned to appear and to show cause, if any, to this Court on the 3rd day of November 1987 at 10h00 a.m., why the said Respondent Company should not be placed under final winding-up Order.
3. That a copy of this Rule *Nisi* be served on the Respondent Company at its registered office and be published forthwith once in the *Government Gazette* and in a Johannesburg daily newspaper.

By the Court.—D. G. Llewellyn, Ass. Registrar. /ws.

Feinstein Inc. Tel.: 833-6835. Ref. Mr Snoyman.

ORDERS VAN DIE HOF (vervolg) • ORDERS OF THE COURT (continued)

Case 16207/87

IN THE SUPREME COURT OF SOUTH AFRICA
(Witwatersrand Local Division)

Johannesburg, the 30th day of September 1987 before the Honourable Mr Justice Goldstone

In the matter between **Flamingo Laundries Pty Ltd**, Applicant, and **Krophile Investments Pty Ltd**, having its registered office at 16 Keyes Court, 12 Keyes Avenue, Rosebank, Johannesburg, Respondent

Having heard Counsel for the Applicant and having read the Application:

It is Ordered:

1. That the above-mentioned Respondent Company be and is hereby placed under provisional winding-up Order in the hands of the Master.
2. That a Rule *Nisi* do issue calling upon all persons concerned to appear and to show cause, if any, to this Court on the 27th day of October 1987 at 10h00 a.m., why the said Respondent Company should not be placed under final winding-up Order.
3. That a copy of this Rule *Nisi* be served on the Respondent Company at its registered office and be published forthwith once in the *Government Gazette* and in a Johannesburg daily newspaper.

By the Court.—D. G. Llewellyn, Registrar. /mm
Starfield and Kampel. Ref. P. Kampel.

**Noord-Kaapse Afdeling, Kimberley
Northern Cape Division, Kimberley**

Saak 1230/87

IN DIE HOOGGEREGSHOF VAN SUID-AFRIKA
(Noord-Kaapse Afdeling)

Kimberley, die 30ste dag van September 1987 voor Sy Edele Regter-President Van Rhyen (In Kamers)

In die saak tussen **Kroonstad Wes Koöperasie Bpk.**, Applikant, en **De Smidt Broers (Edms.) Bpk.**, met geregistreerde kantoor op die plaas "Rooikop", Douglas distrik, Respondent

Na aanhoor van die Advokaat en na deurlees van die betrokke stukke geliasseer:

Gelas die Hof:

1. Dat die Respondent Maatskappy hiermee in voorlopige Likwidasie geplaas word.
2. Dat 'n Bevel *Nisi* hiermee uitgereik word wat alle belanghebbende persone oproep om in hierdie Hof op die 30ste dag van Oktober 1987 om 10h00 redes, indien enige, aan te voer waarom:
 - (a) Die Respondent Maatskappy nie in finale Likwidasie geplaas sal word nie.
3. Dat hierdie Bevel *Nisi* en afskrif van die Kennisgewing van Mosie en aanhangsels aan die Respondent Maatskappy se Hoofkantoor beteken word en onverwyld gepubliseer word—eenmaal in die *Staatskoerant* en eenmaal in die "Volksblad".

Deur die Hof.—H. J. Brand, Griffier.
FH & H.

**Plaaslike Afdeling Durban en Kus, Durban
Durban and Coast Local Division, Durban**

Case 5194/87

IN THE SUPREME COURT OF SOUTH AFRICA
(Durban and Coast Local Division)

Durban, the 27th day of August 1987 before the Honourable Mr Justice Van Heerden

In the matter between **Vanjor Investments (Pty) Limited**, Applicant, and **Bushbucks Football Club (Pty) Limited** Kessel Feinstein, 3rd Floor, Durban Bay House, 333 Smith Street, Durban, Respondent

Upon the Motion of Counsel for the Applicant and Respondent and upon reading the Notice of Motion and the other documents filed of record:

It is Ordered:

1. That **Bushbucks Football Club (Pty) Limited** (hereinafter referred to as "the Respondent") and all interested persons are hereby called upon to show cause, if any, before this Honourable Court on the 25th day of September 1987 at 9.30 a.m. or as soon thereafter as the matter may be heard, why the Respondent should not be wound up.
2. That this order shall operate as an order provisionally winding up the Respondent.
3. That unless the provisional or final liquidator is specifically authorised to the contrary by order of a competent court he shall not be entitled merely by reason of this order to take into his possession or under his control any of the assets or the business of **Bushbucks Football Club**; it being recorded that **Lawrence Ngubane** disputes that the Respondent has any interest whatsoever in the said football club.
4. That this order be served on the Respondent forthwith and published on or before the 18th day of September 1987, once in the *Government Gazette* and once in a daily newspaper published and circulating in Durban.

By Order of the Court.—A. Welgemoed, Registrar. (Act. Asst.)
Berkowitz Kinkel Cohen Wartski Greenberg (12). /lr.

ORDERS VAN DIE HOF (vervolg) • ORDERS OF THE COURT (continued)

Case 5194/87

**IN THE SUPREME COURT OF SOUTH AFRICA
(Durban and Coast Local Division)**

Durban, the 25th day of September 1987 before the Honourable Mr Justice Galgut

In the matter between **Vanjor Investments (Pty) Limited**, Applicant, and **Bushbucks Football Club (Pty) Limited**, Kessel Feinstein, 3rd Floor, Durban Bay House, 333 Smith Street, Durban, Respondent

Upon the Motion of Counsel for the Applicant and upon reading the provisional winding up order issued out of this Court on the 27th day of August 1987 and the other documents filed of record:

*It is Ordered:*That the aforesaid rule *nisi* is hereby extended until the 23rd October 1987, the publication to take place on or before the 16th October 1987.

By Order of the Court.—F. S. Botha, Registrar.

Berkowitz Kirkel Cohen Wartski Greenberg (12). /lr

Case 5827/87

**IN THE SUPREME COURT OF SOUTH AFRICA
(Durban and Coast Local Division)**

Durban, the 23rd day of September 1987 before the Honourable Mr Justice Squires (Acting Judge)

In the matter between **Arthur Patrick Niel Barthus**, Applicant, and **A.C.I. Road and Airfreight CC**, M. D. Hopely and Company, 1st Floor, Connoisseur House, 24 Anderson Road, Pinetown, Natal, Respondent

Upon the Motion of counsel for the Applicant and upon reading the Notice of Motion and the other documents filed of record:

It is Ordered:

1. That A.C.I. Road and Airfreight C.C. (hereinafter referred to as "the Respondent") and all other interested persons, be and they are hereby called upon to show cause, if any, to this Honourable Court on the 23rd day of October 1987 at 09h30 in the forenoon or so soon thereafter as Counsel may be heard, why the Respondent should not be wound up.

2. That this order shall operate as an order provisionally winding-up the Respondent.

3. That this order be published on or before the 16th day of October 1987, once in the *Government Gazette* and once in a daily newspaper published in Durban and circulating in Natal, and that service of this order and of copies of the Applicant's Notice of Motion and the affidavit accompanying it be effected forthwith on the Respondent at its registered office.

By Order of the Court.—L. Bothma, Act. Asst. Registrar.

Ditz Inc. (2). cng.

Case 5905/87

**IN THE SUPREME COURT OF SOUTH AFRICA
(Durban and Coast Local Division)**

Durban, the 28th day of September 1987 before the Honourable Mr Justice Bristowe

In the matter between **Anthony Earnshaw Hopper**, Applicant, and **M & B Fire and Pipe Work Services (Pty) Limited**, 1st Floor, Outfitters Building, 3 Brickhill Road, Durban, Natal, Respondent

Upon the Motion of Counsel for the Applicant and upon reading the Notice of Motion and the other documents filed of record:

It is Ordered:

1. That M & B Fire and Pipe Work Services (Proprietary) Limited, which is hereinafter referred to as "the Respondent", and all other interested persons be and they are hereby called upon to show cause, if any, before this Honourable Court on the 29th day of October 1987 at 9.30 a.m. or so soon thereafter as Counsel may be heard why the Respondent should not be wound up.

2. That this order operates as an order provisionally winding-up the Respondent.

3. That this order be served forthwith upon the Respondent and that the order be published on or before the 16th October 1987, once in the *Government Gazette*, and once in a daily newspaper published and circulating in the Magisterial District of Durban, Natal.

By Order of the Court.—L. L. Venter, Registrar.

Van Onselen Coppen & O'Connell. (26). cng.

Case 5179/87

**IN THE SUPREME COURT OF SOUTH AFRICA
(Durban and Coast Local Division)**

Durban, the 25th day of September 1987 before the Honourable Mr Justice Galgut

In the *ex parte* application of **Sewcor (Pty) Limited**, 4th Floor, Fenton House, Fenton Road, Durban, Applicant

Upon the Motion of Counsel for the Applicant and upon reading the Notice of Set Down and the other documents filed of record:

It is Ordered:

1. That the applicant be and is hereby placed under provisional winding up in the hands of the Master.

2. That a rule *nisi* be issued calling upon all interested persons to appear and to show cause, if any, to this Court on Friday the 9th day of October 1987 at 9.30 a.m. why the said Applicant company should not be placed under final winding-up.

ORDERS VAN DIE HOF (vervolg) • ORDERS OF THE COURT (continued)

3. That a copy of the rule *nisi* be published on or before Friday, the 2nd day of October 1987, in the *Government Gazette* and a daily newspaper published and circulating in the Magisterial District of Durban, Natal.

4. Directing that the costs of this application be part of the costs of the winding-up of the Applicant.

5. The application papers and a copy of this Rule is to be served on the applicant company at its registered address.

By Order of the Court.—L. Bothma, Act. Asst. Registrar.

Nolan and Company (115), Applicant's Attorneys, 2nd Floor, Vareco House, 30 Masonic Grove, Durban. Ph.: 3040634.

Case 5179/87

IN THE SUPREME COURT OF SOUTH AFRICA
(Durban and Coast Local Division)

Durban, the 5th day of October 1987 before the Honourable Mr Justice Broome

In the matter of **Sewcor (Proprietary) Limited**, 4th Floor, Fenton House, Fenton Road, Durban, Applicant

Upon the Motion of Counsel for the Applicant and upon reading the Provisional Winding-Up order issued out of this Court on the 25th September 1987 and the other documents filed of record:

It is Ordered:

1. That the rule *nisi* issued on 25th September 1987 be and is hereby extended to Friday the 23rd day of October 1987 calling upon all interested persons to appear and show cause, if any, to this Court at 9.30 a.m. why the Applicant company should not be placed under final winding-up.

2. That a copy of the rule *nisi* be published on or before Friday the 16th day of October 1987, in the *Government Gazette* and a daily newspaper published and circulating in the Magisterial District of Durban, Natal

By Order of the Court.—L. Bothma, Act. Asst. Registrar.

Nolan & Co. (115), Applicant's Attorney, 2nd Floor, Vareco House, 30 Masonic Grove, Durban. Ph.: 3040634.

Oranje-Vrystaatse Provinsiale Afdeling, Bloemfontein
Orange Free State Provincial Division, Bloemfontein

Saak 3333/87

IN DIE HOOGGEREGSHOF VAN SUID-AFRIKA
(Oranje-Vrystaatse Provinsiale Afdeling)

Te Bloemfontein, op die 18de dag van Augustus 1987 voor Sy Edele Regter Kotze

In die saak tussen **Debora Jacoba du Plessis**, Applikante, en **Debora Jacoba Retief Coetzee**, 1ste Respondente, **Die Registrateur van Aktes**, 2de Respondent, **Christoffel Jacobus Lodewikus Foley**, 3de Respondent

Na oorweging van die Kennisgewing van Mosie en ander dokumente wat ingedien is en na aanhoor van die advokaat vir Applikant:

Word dit Gelas:

1. Dat die eerste respondente opgeroep word om redes, indien enige, aan te voer in hierdie Agbare Hof op Donderdag, 3 September 1987, om 10h00 waarom 'n bevel met die volgende bepalinge nie gemaak sal word nie:

1.1 Dat eerste respondente tot verkwyter verklaar word.

1.2 Dat eerste respondente verbied word om op enige wyse hoegenaamd te handel met die bates van haar boedel, dit te vervreem, te verkoop, met verband te beswaar, of om enige ooreenkoms hoegenaamd aan te gaan met enigiemand.

1.3 Dat **Hermanus Badenhorst** hierby aangestel word as kurator bonis in die boedel van eerste respondente, met die volgende magte:

(i) Om al die bates van die eerste respondente in ontvangs te neem, te bewaar, te beheer en te administreer.

(ii) Om enige regsgeding wat in belang is van die eerste respondente, of vir die deeglike en behoorlike administrasie van haar boedel, in te stel of voort te sit.

(iii) Om enige besigheid of onderneming van die gesegde eerste respondente, onderworpe aan enige toepaslike regsbeveling, voort te sit of te staak.

(iv) Om enige gelde wat van tyd tot tyd beskikbaar mag word en wat nie onmiddellik benodig word vir die doeleindes waarna in Artikel 82 (c) van die Wet op Administrasie van Boedels, Wet No. 66 van 1965, verwys word nie, te belê, of te her-belê.

(v) Om gelde op te neem by wyse van verband, oor of verpanding van enige van die roerende of onroerende eiendomme van die eerste respondente vir die betaling van haar skulde of die betaling van enige skuld of uitgawe aangegaan of aangegaan te word vir haar onderhoud, of andersins, vir die voordeel of vir die verbetering van enige van haar eiendomme.

(vi) Om enige eiendom, hetsy roerend, hetsy onroerend, hetsy in die geheel, hetsy gedeeltelik, behorende aan die gesegde eerste respondente, te verhuur, te verruil, te verdeel, te vervreem en vir enige wettige deel te ver-hipotikeer of te verpand.

(vii) Om uitvoering te gee aan enige kontrak handelende met die gesegde eerste respondente se eiendom en wat deur haar gesluit is of namens haar gesluit is, voor verlening van hierdie bevel.

(viii) Om enige eiendom, hetsy roerende, hetsy onroerend, tot voordeel van die eerste respondente te verkry, hetsy deur te koop, hetsy andersins.

(ix) Om enige bevoegdheid uit te oefen of enige toestemming wat nodig is vir die uitoefening van enige bevoegdheid te verleen waar sodanige bevoegdheid in die gesegde eerste respondente gevestig is, vir haar voordeel, of in die aard van die voordelige belang vir haar is.

(x) Om enige inkomste of kapitaal van die boedel van die eerste respondente aan te wend vir haar onderhoud of voordeel, vir die onderhoud, opvoeding of bevordering van enige persoon afhanklik van die eerste respondente, skulde deur haar verskuldig te betaal en vir die instandhouding, behoud en veilige bewaring of verbetering van enige van haar eiendom.

1.4 Dat die magte verleen aan die gesegde kurator bonis vermeld in sub-paragraaf 1.3 (i) tot (x) hiervan, uitgeoefen word onderworpe aan die Meester se toestemming en die verskaffing van behoorlike sekuriteit aan gemelde Meester.

1.5 Dat die kurator bonis kennis gee van hierdie bevel, een maal in die *Staatskoerant* en in die *Volksblad*, binne veertien (14) dae na datum van die bevel.

ORDERS VAN DIE HOF (vervolg) • ORDERS OF THE COURT (continued)

1.6 Dat die koste van hierdie aansoek, soos tussen prokureur en eie kliënt insluitend die koste vir die aansoek vir die aanstelling van die kurator bonis, betaal word uit die boedel van die eerste respondente.

2. Dat paragraaf 1.2 hierbo, sal geld as 'n interim interdik met onmiddellike werking.

3. Dat die tweede respondente, hangende 'n finale beslissing in hierdie aansoek, verbied word om transport van Erf 1146, geleë te Virginia te registreer in die naam van derde respondente.

Op las van die Hof.—S. Kruger, Hofgriffier.

Rosendorff Reitz & Barry.

Saak 3333/87

IN DIE HOOGGEREGSHOF VAN SUID-AFRIKA
(Oranje-Vrystaatse Provinsiale Afdeling)

Te Bloemfontein, op die 1ste dag van Oktober 1987 voor Sy Edele Regter Malherbe

In die saak tussen **Debora Jacoba du Plessis**, Applikante, en **Debora Jacoba Retief Coetzee**, Eerste Respondente, **Die Registrateur van Aktes**, Tweede Respondent, **Christoffel Jacobus Lodewikus Foley**, Derde Respondent

Na oorweging van die Kennisgewing van Mosie en ander dokumente wat ingedien is en na aanhoor van die Advokaat vir Applikante:

Word dit Gelas dat:

Die bevel uitgereik deur hierdie Hof op die 18de dat van Augustus 1987 bekragtig word uitgeslote paragraaf 2 van die bevel.

Op Las van die Hof.—Hofgriffier.

Rosendorff & Reitz Barry.

TERSYDESTELLINGS EN AFWYSINGS VAN AANSOEKE

Kennis word hiermee deur die Meester van die Hooggeregshof van Suid-Afrika, soos vermeld, gegee van die tersydestelling van voorlopige bevel van sekwestrasie/likwidasië en die afwysing van aansoeke.

Die inligting word verstrek in die volgorde: Boedelnommer; die applikant; die verweerder; die datum van uitreiking van die voorlopige bevel; die Afdeling van die Hooggeregshof; die datum van die afwysingsbevel.

SUPERSESIONS AND DISCHARGE OF PETITIONS

Notice is hereby given by the Master of the Supreme Court of South Africa, as stated, of the supersession of provisional orders of sequestration/liquidation and the discharge of petitions.

The information is given in the following order: Estate number; the applicant; the respondent; the date of the provisional order granted; the Supreme Court Division; the date of the discharge order.

T750/87—**Jan Jonathan Labuschagne Buitenbach**, Applikant; **Jan Hendrik Buitendag Tarentaalkraal (plaas) Thabazimbi**, Respondent; 11 Maart 1987, Transvaalse Provinsiale; 7 April 1987.

T1494/87—**Dawid Jacobus Pieterse**, Applikant; **Weldcorr Engineering (Pty) Limited**, Respondent; 21/5/87, Transvaalse Provinsiale; 8/9/87.

C493/87—**David Schur & Marais**, Applikant; **Petronella Wilna Felicity Esterhuizen**, residing at 6 Cabrescent, Worcester, Respondent; 7/8/87, Cape of Good Hope Provinsiale; 4/9/87.

C499/87—**James Ewart Bater Dark**, Applicant; **Theunis Judeel**, c/o Berg en Dal Boerdery Grootkloof Area, Worcester, Respondent; Cape of Good Hope Provinsiale.

C479/87—**Anna Johanna Janse van Rensburg**, Applikant; **Melt van der Spuy Myburgh**, woonagtig te Uygelaan 21, Stilbaai, Respondent; 30/7/87, Kaap die Goeie Hoop Provinsiale; 16/9/87.

E99/87—**Kildebt Investments**, Applicant; **Johannes Frederick Andries Potgieter**, presently residing at 3 Omdraai Street, Jeffreys Bay, Respondent; 13/5/87, Eastern Cape; 9/9/87.

E197/87—**Buffalo Building Supplies (Pty) Ltd**, Applicant; **Derrick Stephen Hilton**, residing at 5 Church Street, Breidbach, King William's Town and who carries on business as a building contractor, Respondent; 10/9/87, Eastern Cape; 15/9/87.

N331/87—**Volkswaas Industrial Bank Limited**, Applicant; **David Christopher Goss**, Respondent; 13/8/87, Natal Provinsiale; 4/9/87.

T1411/84—**Die Meester van die Hooggeregshof**, Applikant; **Johannes Hermanus Hendrikus Fourle**, Respondent; 3/7/84, Transvaalse Provinsiale; 11/8/87.

T2457/87—**Sarah Maryna Burger**, Applikant; **Pieter Daniel Burger**, Respondent; 14/8/87, Transvaalse Provinsiale; 15/9/87.

T2290/87—**John Louis Carter Fourle N.O.**, First Applicant, **Andrew David Wilkins N.O.**, Second Applicant; **Jet Freight Services (Cape) (Pty) Ltd**, Respondent; 14/7/87, Transvaal Provinsiale; 8/9/87.

T2458/87—**Willem Constantyn Janson**, Applikant; **Christiaan Burger**, van die plaas Lanatimond, Barberton, Respondent; 18/8/87, Transvaalse Provinsiale; 15/9/87.

T2782/87—**Francis Joseph Albert McCabe**, Applicant; **Johannes Hendrikus Viljoen**, Respondent; 25/8/87, Witwatersrandse Plaaslike; 22/9/87.

T4242/86—**Eland International (Prop.) Ltd, Ex parte**; 31/10/86, Witwatersrand Local; 9/9/87.

T4771/86—**Lyndor Investments (Pty) Limited**, Applicant; **Mac Baren Investments (Pty) Limited**, Respondent; 9/12/86, Witwatersrand Local; 28/4/87.

T2301/87—**Johannes Frederick Fourie**, Applikant; **Rudolph Johannes Strydom**, Respondent; 28/7/87, Witwatersrandse Plaaslike; 8/9/87.

N285/87—**Ahmed Adam**, Applicant; **Essop Patel**, Respondent; 16/7/87, Natal Provinsiale; 17/9/87.

N293/87—**Alexander Ogilvie Bischoff**, Applicant; **Alexander Dirk Bischoff & Julie Heather Bischoff**, married in community of property, Respondent; 15/7/87, Natal Provinsiale; 18/9/87.

**GEREGTELIKE EN ANDER OPENBARE VERKOPE
SALES IN EXECUTION AND OTHER PUBLIC SALES
GEREGTELIKE VERKOPE • SALES IN EXECUTION
TRANSCVAAL**

Case 1667/87

IN THE MAGISTRATE'S COURT FOR THE DISTRICT OF ALBERTON HELD AT ALBERTON

In the matter between **United Building Society Limited**, Plaintiff, and **Pieter Johannes de Klerk**, Defendant

Be pleased to take notice that a Sale in Execution in the above matter will take place on the 25th November 1987 at 10.00 a.m. in the forenoon at:

The offices of the Messenger of the Court, Alberton, being Jobria Court, 4 Du Plessis Street, Florentia, Alberton, of the following:

Erf 1133 Mayberry Park, Registration Division I.R. Transvaal, situated at:

30 Apiesdoring Street, Mayberry Park, Alberton in a good residential area. The following information is furnished *re* the improvements, though in this respect nothing is guaranteed.

Improvements: North facing brick under tile dwelling comprising: Entrance hall, lounge, diningroom, 3 bedrooms, 2 bathrooms/wc, kitchen, attached single garage/servants wc, swimmingpool/paving and precast walls.

Zoning: Residential Area.

The property hereby sold is in a White Group area.

Terms:

1. Ten per centum (10%) of the purchase price shall be paid at the time of the sale and the following shall be secured by a bank or building society guarantee in a form acceptable to the Plaintiff's conveyancers:

1.1 The full balance of the purchase price; and

1.2 Interest on the amount of the Plaintiff's claim, calculated at the current rate referred to in the Warrant of Execution (and in the event of there being any other preferent creditor then the interest payable upon such preferent creditors claim) from the date of sale to the date of Transfer.

The guarantee shall be delivered by the purchaser to the Plaintiff's conveyancers within fourteen (14) days of the date of sale and shall provide for the payment of the full balance and any such interest payable as aforesaid provided that if the Plaintiff be the purchaser then no deposit or guarantee will be necessary and the Plaintiff shall pay the full purchase price plus interest to the Messenger of the Court in cash against transfer.

Signed and dated at Alberton on this the 29th September 1987.

(Sgd.) J. Sherman, for Jack Sherman, Plaintiff's Attorneys, 2nd Floor, United Building, 24 Voortrekker Road, Alberton.

To: The Clerk of the Court Alberton.

Case 8037/87

IN THE SUPREME COURT OF SOUTH AFRICA

(Transvaal Provincial Division)

In the matter between **S A Permanent Building Society**, Plaintiff, and **Gerhardt Froneman and Angelina Fredreika Jooste**, Defendant

Pursuant to a Judgment of the above Court and Writ of Execution dated the 28th day of July 1987, the undermentioned property will be sold in execution at 11h00 on Friday the 30th October 1987 at the offices of the Deputy Sheriff, 43E Murray Avenue, Brits.

Erf 331, situate in the township of Brits, Registration Division J Q Transvaal;

Measuring 1 115 square metres;

Held by the Defendants under Deed of transfer No. T59177/86;

Known as 50 Harrington Street, Brits.

The following improvements are situate on the property although in this respect nothing is guaranteed:

Tiled roof, 1½ bathrooms and toilets, Wall to Wall carpets, kitchen, lounge, Dining Room, 2 bedrooms.

Outbuildings: 1 Garage, 1 Servants court.

The Conditions of sale, which will be read immediately prior to the sale, are lying for inspection at the offices of the Deputy Sheriff.

Signed at Pretoria, this the, 16th day of September 1987.

(Sgd) M. S. L. Coetzee, Plaintiff's Attorney, c/o Findlay & Niemeyer, 635 Permanent Building, Paul Kruger Street, Pretoria. Ref: Mrs Rowe.

Case 5807/86

IN THE SUPREME COURT OF SOUTH AFRICA

(Transvaal Provincial Division)

In the matter between **South African Permanent Building Society**, Plaintiff, and **Dawid Johannes Gouws**, Defendant

Pursuant to a Judgment of the above Court and Writ of Execution dated the 6th November 1986, the undermentioned property will be sold in execution at 9.30 a.m. on Friday the 30 October 1987, at the offices of the Deputy Sheriff 43E Murray Avenue, Brits, to the highest bidder:

Erf 138, situate in the Township Elandsrand, Registration Division J Q Transvaal;

Measuring 1 261 square metres;

Held by the Defendant under Deed of Transfer No. T28095/78;

Known as 29 Drakensburg Crescent, Elandsrand Brits;

The following improvements are situate on the property, although in this respect nothing is guaranteed.

A dwelling house consisting of three bedrooms, lounge, diningroom, two bathrooms and toilet.

Outbuildings consist of garage and toilet.

The conditions of Sale, which will be read immediately prior to the sale, are lying for inspection at the offices of the Deputy Sheriff 43E Murray Avenue, Brits.

Signed at Pretoria, this 11th day of September 1987.

(Sgd) M. S. L. Coetzee, Plaintiff's Attorney, c/o Findlay & Niemeyer, 635 Permanent Building, Paul Kruger Street, Pretoria. Tel.: 26-2487. Ref.: Mrs Rowe.

IN THE SUPREME COURT OF SOUTH AFRICA

(Transvaal Provincial Division)

In the matter between **The South African Permanent Building Society**, Plaintiff, and **Johanna Franciena Janse van Rensburg**, Defendant

Pursuant to a judgment of the above Court and Writ of Execution dated the 4th day of January 1985, the undermentioned property will be sold in execution at 10 a.m. on Wednesday, the 4th November 1987 at the office of the Deputy Sheriff, 142 Struben Street, Pretoria, to the highest bidder:

Erf 387, situate in the township of Claremont, Registration Division J.R. Transvaal.

Measuring 2 800 square metres:

Held by the Defendant under Deed of Transfer No. T35757/1978, dated the 8th December 1978.

Known as 1103 and 1105 Deborah Street, Claremont, Pretoria.

The following improvements are situate on the property, although in this respect, nothing is guaranteed:

First House: 1 Lounge, 1 kitchen, 2 bedrooms, 1 bathroom and a toilet.

Second House: 1 Lounge, 1 Kitchen, 3 bedrooms, 1 bathroom and a toilet.

Outbuildings: For the second house only consist of a garage, servant's room and toilet.

Signed at Pretoria, this 25 day of September 1987.

(Sgd.) M. S. L. Coetzee, Plaintiff's Attorney, c/o Findlay & Niemeyer, 635 Permanent Building, Paul Kruger Street, Pretoria. Tel.: 26-2487. Ref.: Mrs Rowe.

Case 10757/87

IN THE SUPREME COURT OF SOUTH AFRICA

(Witwatersrand Local Division)

In the matter between **South African Permanent Building Society**, Plaintiff, and **One Sixty Five Oxford Properties CC**, Defendant

In execution of a Judgment of the Supreme Court of South Africa (Witwatersrand Local Division) in this suit, a sale without reserve will be held at the office of the Deputy Sheriff, 131 Marshall Street, Johannesburg at 10h00 on 5th November 1987 in the forenoon, of the undermentioned property of the Defendant on Conditions to be read out by the Auctioneer at the time of the sale and which may be inspected at the office of the Deputy Sheriff prior to the sale.

Certain: Erf 101 Illovo Township, Registration Division I.R., Transvaal;

Situation: 265 Oxford Road, Illovo, Johannesburg;

Area: 3 718 (three thousand seven hundred and eighteen) square metres;

Improvements (not guaranteed): A single storey semi-detached house and two cottages under iron roof, consisting of three bathrooms, fitted carpets and tiled floors and single garage.

Terms: 10% of the purchase price in cash on the day of the sale; the balance and interest on the full purchase price at current bond rates payable against registration of transfer, to be secured by a bank, building society or other acceptable guarantee to be furnished within 14 (fourteen) days from the date of sale. Auctioneer's charges are payable on the day of the sale and calculated at 5% on the proceeds of the sale up to a price of R10 000,00 and thereafter 2½%, to a maximum fee of R5 000,00 and a minimum of R30,00.

Dated at Johannesburg on this the 1st day of October 1987.

Sgd. A. Lowndes, for Smith & Lowndes, Plaintiff's Attorneys, 10th Floor, S A Centre, 253 Bree Street, P.O. Box 8274, Johannesburg. Tel.: 337-6015. Ref.: Mr Lowndes/SP 257.

Case 4963/1987

IN THE MAGISTRATE'S COURT FOR THE DISTRICT OF BOKSBURG HELD AT BOKSBURG

In the matter between **South African Permanent Building Society**, Plaintiff, and **Leon Olckers**, 1st Defendant, **Maria Johanna Olckers**, 2nd Defendant

On the 6th day of November 1987 at 11h15 a public auction sale will be held in front of the entrance to the Magistrate's Court, Adderley Street, Boksburg at which the Messenger of the Court, pursuant to a judgment of the Court in this Action, warrant of execution issued in terms thereof and attachment in execution made thereunder sell:

Certain Erf 746 Atlasville Extension 1 Township, Registration Division I.R. Transvaal.

Measuring 1 126 (One Thousand One Hundred and Twenty Six) Square Metres.

Also known as 41 Pheasant Road, Atlasville Extension 1, Boksburg.

Improvements: (which are not warranted to be correct and are not guaranteed)

Detached single storey brick residence consisting of 3 Bedrooms, Lounge, diningroom, Familyroom, 2 Bathrooms, kitchen and outbuildings of similar construction consisting of: n/a.

(Hereinafter called "the property".)

The Material Conditions of the Sale are:

1. The sale shall, in all respects, be governed by the Magistrate's Court Act, 1944 and the Rules made thereunder or any amendment thereof or substitution thereof and, subject thereto, the property shall be sold "voetstoots" to the highest bidder without reserve.

2. The price shall bear interest at the rate of 16,5 per centum per annum, or if the claim of the South African Permanent Building Society exceeds the price, interest amounting to the same as interest at that rate on that claim subject to such interest not exceeding the maximum allowed by Laws.

3. The purchaser shall be obliged pay a deposit of 10% (Ten Per Centum) of the price R400,00 (Four Hundred Rand) (whichever is the greater) immediately after the sale and the balance of the price and interest shall, within 14 (Fourteen) days of the date of sale be paid or be secured by unconditional or approved bank and/or building society guarantee/s payable to the Messenger of the Court and/or such other person/s as he requires on transfer of the property to the purchaser.

4. The purchaser shall be liable for and shall pay to the Plaintiff's conveyancers on request the fees of the Messenger of the Court for acting as auctioneer and all amounts necessary to obtain transfer of the property, including stamp duty, other costs of transfer and all such rates and taxes and other amounts as are payable to obtain a Certificate in terms of Section 50 of the Local Government Ordinance (Transvaal) 1939 or any amendment of substitution therefor.

5. Possession and occupation of the property shall, subject to the rights of any existing tenant/s pass to the purchaser upon the sale being effected from which date all benefits, risks and liabilities shall pass to the purchaser.

Dated at Boksburg on this the 24th September 1987.

Hendry Tucker & Partners, 2nd Floor, Permanent Bld, 312 Commissioner Street, Boksburg. Tel.: 892-3400. Ref.: Mr Klinkert/EDUP.

Case 25125/87

IN THE MAGISTRATE'S COURT FOR THE DISTRICT OF JOHANNESBURG HELD AT JOHANNESBURG

In the matter between **Sandton Finance (Pty) Limited**, Plaintiff, and **G. V. Blom**, Defendant

In pursuance of a Judgment in the Court of the Magistrate of Johannesburg and a Warrant of Execution dated the 10th day of June 1987, the following property will be sold in execution on the 11th day of November 1987 at 10h00 at the messenger's offices, 10 Park Street, Kempton Park, to the highest bidder:

Certain: Erf 1063 Norkem Park Ext 2 Township.

Measuring: 1 009 square metres.

Known as: 5 Sand River Road, Norkem Park, Kempton Park.

Conditions of Sale

1. The property shall be sold without reserve and to the highest bidder and shall be subject to the terms and conditions of the Magistrate's Court Act and the Rules made thereunder, and of the title deeds, in so far as these are applicable.

2. The following improvements on the property have been reported, but nothing is guaranteed:

A dwelling house with the usual outbuildings.

Zoned special residential. White Group Area.

3. *Terms:* The Purchase price shall be paid as to ten per centum (10%) thereof on the signing of the Conditions of Sale and the unpaid balance together with interest thereon at the rate stipulated in the 1st Mortgage Bond registered against the property to date of payment, within fourteen (14) days to be paid or secured by an approved Bank or Building Society guarantee.

4. *Conditions:* The full Conditions of Sale which will be read by the Messenger of the Court, Kempton Park, immediately prior to the sale, may be inspected at his office, Kempton Park and at the offices of Messrs Bredell Murray & Ronbeck, 17th Floor, Kine Centre, Commissioner Street, Johannesburg.

Dated at Johannesburg on this the 2nd day of October 1987.

(Sgd) E. A. Ronbeck, for Bredell Murray & Ronbeck, Plaintiff's Attorneys, 17th Floor, Kine Centre, Commissioner Street, Johannesburg.

Case 604/87

IN THE MAGISTRATE'S COURT FOR THE DISTRICT OF MIDDELBURG HELD AT MIDDELBURG

In the matter between **South African Permanent Building Society**, Execution Creditor, and **F. J. A. du Toit**, 1st Execution Debtor, **A. M. du Toit**, 2nd Execution Debtor

In execution of a Judgment of the Magistrate's Court for the District of Middelburg dated 17th August, 1987 and in pursuance of an Attachment in Execution dated 1st September, 1987 a Sale by Public Auction will be held in front of the Magistrate's Court Middelburg on Saturday 31st October, 1987 at 10.00 a.m. of the following immovable property situate at: 15 Murray Street, Middelburg being:

Erf 154 Middelburg, in the Municipality and Division of Middelburg;

In Extent: 506 square metres.

Held by: Francois Jacobus Alwyn du Toit, under Deed of Transfer No. 24458/86 dated 26th June, 1986 and subject to the conditions referred to therein.

The following improvements are situate on the property although nothing in this respect is guaranteed: Dwellinghouse and outbuildings.

The Conditions of Sale will be read immediately prior to the Sale, and are lying for inspection at the Office of the Messenger of the Court at Middelburg.

Terms: 10% of the Purchase price and 4% Messenger's (Auctioneer's) charges in cash on the date of the Sale; the balance against transfer to be secured by a Bank or Building Society or other acceptable Guarantee, to be furnished to the Messenger of the Court within twenty-one (21) days from date of sale.

Dated at Uitenhage this 29th day of September, 1987.

J. S. Levy & Levy, c/o South African Permanent Building Society, 38a, Caledon Street, Graaff-Reinet, P.O. Box 10, Uitenhage.

Case 8649/87

IN THE SUPREME COURT OF SOUTH AFRICA

(Witwatersrand Local Division)

In the matter between **South African Permanent Building Society**, Plaintiff, and **John Selborne Hulley**, Defendant

In Execution of a Judgment of the Supreme Court of South Africa (Witwatersrand Local Division) in this suit, a sale without reserve will be held at the office of the Deputy Sheriff, Elna Randhof, cnr Selkirk Avenue and Blairgowrie Drive, Randburg at 10 o'clock on 3rd November 1987 in the forenoon, of the undermentioned property of the Defendant on Conditions to be read out by the Auctioneer at the time of the sale and which may be inspected at the office of the Deputy Sheriff prior to the sale.

Certain: Unit comprising Section 16 and its undivided share in the common property in the Malanshof Centre sectional title scheme.

Area: 102 square metres.

Situation: Flat 107 Malanshof Centre, Hans Schoeman Road, Malanshof, Randburg.

Improvements (not guaranteed): "A flat consisting of 2 bedrooms, 2 bathrooms, lounge and fitted carpets".

Terms: 10% of the purchase price in cash on the day of the sale; the balance and interest on the full purchase price at current bond rates payable against registration of transfer, to be secured by a bank, building society or other acceptable guarantor to be furnished within 14 days from the date of sale. Auctioneer's charges are payable on the day of the sale and calculated at 5% on the proceeds of the sale up to a price of R10 000,00 and thereafter 2½%, to a maximum fee of R5 000,00 and a minimum of R30,00.

Dated at Johannesburg on 30th September 1987.

Sgd. S. E. van Zyl, for E. F. K. Tucker Inc., Plaintiff's Attorneys, 48th Floor, Carlton Centre, Commissioner Street, Johannesburg. Tel.: 331-7211.
Ref.: Foreclosures/SAPE 7110-074.

Saak 1162/87

IN DIE LANDDROSHOF VIR DIE DISTRIK VAN HEIDELBERG, TRANSVAAL GEHOU TE HEIDELBERG, TRANSVAAL

In die saak tussen **Die Allied Bouvereniging**, Eiser, en **Stephanus Johannes Bronkhorst**, Verweerder

Ten uitvoerlegging van 'n uitspraak van die Landdroshof vir die distrik van Heidelberg, Transvaal en 'n Lasbrief vir Eksekusie gedateer die 20ste Augustus 1987 sal die eiendom hieronder vermeld per openbare veiling verkoop word voor die Landdroshof, Begemanstraat, Heidelberg op die 30ste dag van Oktober 1987 om 11h00 aan die hoogste bieër, naamlik:

Erf 118 geleë in die dorp Rensburg, Heidelberg, Registrasie Afdeling I.R. Transvaal.

Groot: 1 190 (Eenduisend Eenhonderd en Negentig) vierkante meter:

Gehou kragtens Akte van Transport T 42314/84.

Voorwaardes van Verkoop:

1. Die eiendom word voetstoots verkoop aan die hoogste bieër kragtens die Wet om Magistraatshowe en die regulasies daaronder uitgevaardig en onderhewig aan die voormelde Akte van Transport.

2. Die eiendom is verbeterd.

3. Twintig (20%) persent van die koopprijs is betaalbaar in kontant en die balans teen registrasie van transport van die eiendom in die naam van die koper, wat verseker moet word deur 'n bevredigende Bank of Bouvereniging waarborg, welke waarborg aan die Geregsbode voorsien moet word binne veertien (14) dae vanaf die datum van ondertekening van die Koopoooreenkoms.

4. Die koper sal verantwoordelik wees vir die koste van transport, agterstallige belastinge en alle ander kostes asook vir betaling van munisipale belastinge vanaf datum van koop van die gemelde eiendom.

5. Okkupasie op registrasie van eiendom.

6. Die voorwaardes van verkoop sal gesien kan word ten kantoor van die Geregsbode, Heidelberg.

Geteken te Heidelberg, Transvaal op hierdie 18de dag van Augustus 1987.

(Get) I. J. du P. van den Berg, vir Viljoen & Meek, Prokureurs vir Eiser, Voortrekkerstraat 29, Posbus 21, Heidelberg.

Case 14580/1986

IN THE MAGISTRATE'S COURT FOR THE DISTRICT OF GERMISTON HELD AT GERMISTON

In the matter between **Allied Building Society**, Plaintiff, and **Frederik John Blignaut**, First Defendant, **Nicolene de Freitas**, Second Defendant

In pursuance of a judgment in the Court of the Magistrate of Germiston a Writ of Execution, dated 19th March 1987 the property listed herein will be sold in execution on Tuesday 10th November 1987 at 10h00 in front of the Magistrate's Court, President Street, Germiston to the highest bidder:

Erf 1570 Primrose Township, Registration Division I.R. Tvl.,

Situate on: 30 Maroela Street, Primrose.

Measuring: 973 square metres.

The Judgment Creditor described the improvements on the property as set out hereunder, but no warranties are given in respect thereof:

Improvements

Single detached dwelling under iron consisting of an entrance hall, lounge, dining room, kitchen, pantry, bathroom and wc. Outbuildings are separate from the mainbuilding consisting of garage, 2 rooms, shower, servants room and separate wc.

Zoning: Residential 1.

Group Areas: White 1.

Terms: The purchase price shall be paid as to ten per cent (10%) thereof on the day of the sale and the unpaid balance, together with interest thereon to date of registration of transfer shall be paid or secured by a Bank or Building Society Guarantee within fourteen (14) days of the date of the sale to the Messenger of the Court.

The Conditions of Sale, which will be read immediately prior to the sale, may be inspected at the office of the Messenger of the Court, Germiston.

Wright, Rose-Inness, Louw & Wise, Allied Building, 170 Meyer Street, Germiston. Ref: WmdV/DdK.

Case 2757/1987

IN THE MAGISTRATE'S COURT FOR THE DISTRICT OF ALBERTON HELD AT ALBERTON

In the matter between **Allied Building Society**, Plaintiff, and **Midnight Awakening Call Association**, Defendant

In pursuance of a judgment in the Court of the Magistrate of Alberton a Writ of Execution, dated 4th May 1987 the property listed herein will be sold in execution on Wednesday 11th November 1987 at 10h00 at the Messenger's office, Johria Court, 4 Du Plessis Road, Florentia, Alberton to the highest bidder:

Erf 46 Newmarket Agricultural Holdings, Reg. Division IR Tvl;

Situate on: 46 Goodwood Street, Newmarket.

Measuring: 1.5971 Hectares.

The Judgment Creditor described the improvements on the property as set out hereunder, but no warranties are given in respect thereof:

Improvements

850 seat Hall (Church) under steel sheeting roof with three offices and small hall on West side. Block of 5 offices and ablution block.

Zoning: Agricultural.

Group Areas: White 1.

Terms: The purchase price shall be paid as to ten per cent (10%) thereof on the day of the sale and the unpaid balance, together with interest thereon to date of registration of transfer shall be paid or secured by a Bank or Building Society Guarantee within fourteen (14) days of the date of the sale to the Messenger of the Court.

The Conditions of Sale, which will be read immediately prior to the sale, may be inspected at the office of the Messenger of the Court, Alberton. Wright, Rose-Innes, Louw & Wise, Allied Building, 170 Meyer Street, Germiston. Ref: WmdV/DdK.

Case 5112/1987

IN THE MAGISTRATE'S COURT FOR THE DISTRICT OF ALBERTON HELD AT ALBERTON

In the matter between **Allied Building Society**, Plaintiff, and **Itireleng Ezekiel Khantsi**, First Defendant, **Alice Maleshoeane Khantsi**, Second Defendant

In pursuance of a judgment in the Court of the Magistrate of Alberton a Writ of Execution, dated 7 July 1987 the property listed herein will be sold in execution on Tuesday 10th November at 10h00 at the Messenger's office, Johria Court, 4 Du Plessis Road, Florentia, Alberton to the highest bidder:

The right, title and interest in the leasehold in respect of Lot 534 Township Ramakonopi East.

Situate on: 534 Ramakonopi East, Katlehong.

Measuring: 649 square metres.

The Judgment Creditor described the improvements on the property as set out hereunder, but no warranties are given in respect thereof:

Improvements

Single detached dwelling under tiles consisting of a lounge, diningroom, 4 bedrooms, kitchen, bathroom and wc. Outbuildings are attached to mainbuilding consisting of garage.

Zoning: Residential.

Group Areas: Black.

Terms: The purchase price shall be paid as to ten per cent (10%) thereof on the day of the sale and the unpaid balance, together with interest thereon to date of registration of transfer shall be paid or secured by a Bank or Building Society Guarantee within fourteen (14) days of the date of the sale to the Messenger of the Court.

The Conditions of Sale, which will be read immediately prior to the sale, may be inspected at the office of the Messenger of the Court, Germiston. Wright, Rose-Innes, Louw & Wise, Allied Building, 170 Meyer Street, Germiston. Ref: WmdV/DdK.

Case 5042/1986

IN THE MAGISTRATE'S COURT FOR THE DISTRICT OF ALBERTON HELD AT ALBERTON

In the matter between **Allied Building Society**, Plaintiff, and **Anthony Lewis Greyvenstein**, Defendant

In pursuance of a judgment in the Court of the Magistrate of Alberton a Writ of Execution, dated 3rd November 1986 the property listed herein will be sold in execution on Wednesday 11th November 1987 at 10h00 at the Messenger's Office, Johria Court, 4 Du Plessis Road, Florentia, Alberton to the highest bidder:

Erf 1632 Randhart Extension 2 Township, Registration Division IR, Transvaal;

Situate on: 5 Jasper Street, Randhart.

Measuring: 1 000 square metres.

The Judgment Creditor described the improvements on the property as set out hereunder, but no warranties are given in respect thereof:

Improvements

Single detached dwelling under tiles consisting of a lounge, diningroom, kitchen, 3 bedrooms, bathroom, shower and wc. Outbuildings are attached to the main buildings consisting of double garage, servants room with bathroom and wc.

Zoning: Residential 1.

Group Areas: White 1.

Terms: The purchase price shall be paid as to ten per cent (10%) thereof on the day of the sale and the unpaid balance, together with interest thereon to date of registration of transfer shall be paid or secured by a Bank or Building Society Guarantee within fourteen (14) days of the date of the sale to the Messenger of the Court.

The Conditions of Sale, which will be read immediately prior to the sale, may be inspected at the office of the Messenger of the Court, Alberton.

Wright, Rose-Innes, Louw & Wise, Allied Building, 170 Meyer Street, Germiston. Ref: WmdV/DdK.

Case 8152/87

IN THE SUPREME COURT OF SOUTH AFRICA

(Witwatersrand Local Division)

In the matter between **United Building Society Limited**, Plaintiff, and **Govindsamy Pillay**, First Defendant, **Laurin Cynthia Pillay**, Second Defendant

In Execution of a Judgement of the Supreme Court of South Africa (Witwatersrand Local Division) in the above-mentioned suit a Sale without Reserve will be held at the office of the Deputy Sheriff, at 131 Marshall Street, Johannesburg on the 5th day of November 1987 at 10h00 of the undermentioned property of the Defendant on the Conditions to be read out by the Auctioneer at the offices of the Deputy Sheriff, 131 Marshall Street, Johannesburg prior to the sale.

(Short description of property, situation, and street number):

Erf 590 Lenasia South Extension 1 Township, Registration Division I Q Transvaal and situate at 590 Greenwich Street, Lenasia South Extension 1, measuring 540 square metres.

The following information is furnished *re* the improvements, though in this respect nothing is guaranteed:

Dwellinghouse consisting of 3 bedrooms, bathroom and toilet, entrance/lounge, kitchen/diningroom.

Terms: 10% (Ten per cent) of the purchase price in cash on the day of the sale, the balance payable against registration of Transfer, to be secured by a Bank or Building Society or other acceptable guarantee to be furnished within 14 (fourteen) days from the date of sale. Auctioneers charges, payable on the day of sale, to be calculated as follows: 5% (Five per cent) on the proceeds of the sale up to a price of R10 000,00 (Ten Thousand Rand) and thereafter 2½% (two and a half per cent) up to a maximum fee of R5 000,00 (Five Thousand Rand). Minimum charges R30,00 (Thirty Rand).

Dated: 30 September 1987.

(Sgd) R. S. Rappoport, for Fluxman Rabinowitz & Rubenstein, Plaintiff's Attorneys, First Floor, City Centre, 8 Luttig Street, P.O. Box 116, Roodepoort, 1725. Tel: 763-6121. Ref: R. S. Rappoport.

Case 2827/87

IN THE MAGISTRATE'S COURT FOR THE DISTRICT OF BOKSBURG HELD AT BOKSBURG
Between **Town Council of Boksburg**, Plaintiff, and **J. H. Delport**, Defendant

Persuant to a Judgment granted by the abovenamed Honourable Court dated the 18th May 1987 and a Warrant of Execution, the undermentioned property will be sold on the 6th day of November 1987 at 11.15 am in front of the Magistrate's Court, Adderley Street, Boksburg, to the highest bidder:

Certain Erf: 398 Beyerspark Ext 3.

Known as: 21 Lucas Meyer Street Beyerspark Boksburg.

Measuring: 796 Square Metres.

Held under Deed of Transfer No.: T22361/78, Dated 28/12/78,

Improvements: Single Storey Dwelling Under Tiled Roof, consisting of, Lounge, 3 Bedrooms, Kitchen, 1 Bathroom, Single Garage. (Which are not warranted to be correct, and which are not guaranteed.)

Terms and Conditions

1) 10% (tien per centum) of the purchase price to be paid on the date of the sale and the balance together with interest to be paid or secured by an approved Bank or Building Society Guarantee within 14 (Fourteen) days of the date of the Sale.

2) The Purchaser shall be liable for all costs and expenses to procure transfer including the Messenger of the Court's fees.

3) The Purchaser shall be liable for all outstanding Rates and Taxes.

4) The complete Conditions of Sale may be inspected at the office of the Messenger of the Court, Boksburg.

Dated at Boksburg on this the 21st day of September 1987.

(Sgd) J. P. J. van Vuuren, for Malherbe Rigg & Randwell, Standard Bank Chambers, 264 Commissioner Street, Boksburg. Ref: Mrs Jenner.

Case 7675/87

IN THE SUPREME COURT OF SOUTH AFRICA
(Witwatersrand Local Division)

In the matter between **Allied Building Society**, Plaintiff, and **Lofred Share Block (Proprietary) Limited**, 1st Defendant, **Adam Barnard**, 2nd Defendant

In execution of a Judgment of the Supreme Court of South Africa (Witwatersrand Local Division) in the above-mentioned suit, a sale without reserve will be held in the main entrance hall at the Magistrate's Court, Vanderbijlpark, on Thursday the 29th day of October 1987 at 09h00 of the undermentioned property of the first Defendant on the conditions to be read out by the Auctioneer at the main entrance hall, Magistrate's Court, Vanderbijlpark, prior to the sale:

Sections 3, 20, 21, 22, 23, 24, 25, 26, 32, 33, 34, 35, 36, 37, 38, 39, 40, 41, 42 and 43, as shown and more fully described on Section Plan No.: 314/84 ("the Sectional Plan") in the building or buildings known as Jakaranda Park and the undivided share in the common property in the said land and building or buildings apportioned to the said mortgaged sections in accordance with the participation quotas of the said mortgaged sections;

[Corresponding to Flat Nos.: 3, 20, 21, 22, 23, 24, 25, 26, 32, 33, 34, 35, 36, 37, 38, 39, 40, 41, 42 and 43, Jakaranda Park, Frikie Meyer Boulevard (between Jenner Street and Faraday Boulevard), Vanderbijlpark.]

The following information is furnished *re* the improvements, though in this respect nothing is guaranteed:

Mainbuilding:

20 Flats comprising two bedrooms, combined diningroom and lounge, kitchenette, bathroom.

Outbuildings:

Garage.

Construction: Brik under tile.

Terms: 10% (Ten Per Cent) of the purchase price in cash on the day of the sale, the balance payable against registration of transfer, to be secured by a Bank or Building Society or other acceptable guarantee to be furnished within 14 (fourteen) days from the date of sale.

Auctioneer's charges, payable on the day of the sale, to be calculated as follows: 5% (five per cent) on the proceeds of the sale up to a price of R10 000,00 (ten thousand rand) and thereafter 2½% (two and a half per cent) up to a maximum of R5 000,00 (five thousand rand). Minimum charges R30,00 (thirty rand).

Dated: 8 September 1987.

(Sgd) H. Mer, for Raphaely-Weiner, Attorneys for Plaintiff, 8th Floor, Nedbank Mall, Cor Commissioner and Small Streets, P.O. Box 2590, Johannesburg. Tel.: 331-0111. Ref.: Mr Mer/jg/AL 128.

Saak 3082/87

IN DIE LANDDROSHOF VIR DIE DISTRIK VAN RUSTENBURG GEHOU TE RUSTENBURG
In die saak tussen **Saambou-Nasionale Bouvereniging**, Eiser, en **Jozua Grobler**, Verweerder

Ingevolge uitspraak van bogenoemde Agbare Hof en 'n Lasbrief tot Eksekusie gedateer die 26ste Augustus 1987 sal hierdie ondervermelde eiendom geregtelik verkoop word op die 30ste Oktober 1987 om 11h00 voor die Landdroskantore, Rustenburg aan die persoon wat die hoogste aanbod maak, naamlik:

Gedeelte 5 ('n gedeelte van Gedeelte 1) Erf 861, Rustenburg, Registrasie Afdeling, J.Q. Transvaal;

Groot: 844 vierkante meter;

Gehou: Kragtens Akte van Transport T26547/86 onderworpe aan sodanige voorwaardes as wat in gemelde Akte vermeld staan of na verwys word.

Verkoopsvoorwaardes

1. Die eiendom sal sonder voorbehoud verkoop word aan die hoogste bieder en die verkoping sal onderworpe wees aan die bepalings van die Wet op Landdroshoue, 32 van 1944, en die reëls daaronder uitgevaardig, asmede die voorwaardes vervat in die bestaande titel, sover van toepassing.

2. Na bewering is die eiendom as volg verbeter maar niks word gewaarborg nie:

'n Woonhuis met die gewone buitegeboue.

3. *Terme*

Tien Per Centum (10%) van die koopprys en die koste sal met ondertekening van die verkoopsvoorwaardes betaalbaar wees en die uitstaande balans, tesame met rente teen die koers bepaal in die bestaande eerste verband, indien enige, geregistreer oor die eiendom tot datum van betaling sal binne Veertien (14) dae betaal of deur middel van 'n goedgekeurde bank- of bougenootskapwaarborg verseker word.

4. *Voorwaardes*

Die volledige verkoopsvoorwaardes, wat onmiddellik voor die verkoping deur die Geregsbode, Rustenburg, gelees sal word lê ter insae in die Geregsbode se kantoor te Rustenburg en die kantore van Mnr Jac H. Smit, Leonard & Breytenbach, Eerste Vloer, Sanlamsentrum, Boomstraat, Rustenburg.

Geteken te Rustenburg op hede die 7de dag van September 1987.

Jac H. Smit, Leonard & Breytenbach, Eerste Vloer, Sanlamsentrum, Boomstraat, Rustenburg. (Verwysing Mnr Smit/SB.)

Saak 3066/86

IN DIE LANDDROSHOF VIR DIE DISTRIK VAN ERMELO GEHOU TE ERMELO

In die saak tussen **B & S Vleishandel**, Eksekusieskuldeiser, en **Gys Laurens**, Eksekusieskuldenaar

Ter uitvoering van 'n Vonnis van bogenoemde Agbare Hof en 'n Lasbrief vir Eksekusie gedateer 25 November 1986, word die hiernavermelde eiendom in eksekusie verkoop aan die hoogste bieder, sonder reserwe, op Vrydag 30 Oktober 1987 om 10h00 voor die Landdroskantoor, Ermelo:

Die lewenslange vruggebruik van Gysbert Sybrand Laurens (gebore 26 Oktober 1932) en sy eggenote Christina Louisa Jacoba Laurens (gebore op 1 September 1939) oor:

Gedeelte 3 ('n gedeelte van Gedeelte 2) van die plaas USUTU 250, Registrasie Afdeling I.T., Transvaal; Groot 179, 9616 hektaar.

Ligging: Ongeveer 9 kilometer Suid-Oos van Lothair.

Terme: 10% van die koopprys plus afslaaerskommissie betaalbaar by toeslaan van die bod, en die balans verseker te word binne 14 dae deur Bank- of ander goedgekeurde waarborg.

Voorwaardes: Die volle verkoopsvoorwaardes sal ter insae lê by die kantoor van die Geregsbode, De Clercqstraat 10, Ermelo.

Gedateer te Ermelo op hierdie 8ste September 1987.

Dr M. M. Nolte, Prokureurs vir Eiser, De Clercqstraat 18, Ermelo.

Saak 1498/1987

IN DIE LANDDROSHOF VIR DIE DISTRIK VAN OBERHOLZER GEHOU TE OBERHOLZER

In die saak tussen **Suid-Afrikaanse Permanente Bouvereniging**, Eiser, en **Andries Jacobus van Wyk**, Verweerder

In gevolg uitspraak van die Landdros van Oberholzer en Lasbrief vir Eksekusie teen Goed met datum 20 Julie 1987 sal die ondervermelde eiendom op Vrydag, 6 November 1987 om 10h00 by die kantore van die Landdros Van Zyl Smitshtraat, Oberholzer aan die hoogste bieder verkoop word, naamlik:

Erf 163, geleë in die dorp Oberholzer, Registrasie Afdeling I.Q., Transvaal;

Groot 1 115 (Eenduisend Eenhonderd en Vyftien) vierkante meter;

(Bekend as Ernsstraat 36, Oberholzer.)

Onderhewig aan die volgende voorwaardes:

1. Die eiendom sal "voetstoots" en sonder reserwe verkoop word aan die hoogste bieder, en die veiling sal onderworpe wees aan die voorwaardes van Artikel 66 van die Wet op Landdroshoue van 1944, soos gewysig, onderhewig egter aan die goedkeuring van die eerste verbandhouer, die Suid-Afrikaanse Permanente Bouvereniging.

2. Die koopprys sal betaalbaar wees teen betaling van 10 (Tien) % van die koopprys in kontant onmiddellik na afhandeling van die verkoop, en die onbetaalde balans tesame met rente daarop bereken teen 16 % per jaar tot datum van registrasie van transport, sal binne 21 (Een en Twintig) dae betaal word of gewaarborg word deur 'n goedgekeurde Bank of Bougenootskapwaarborg.

3. Die volgende verbeterings word beweer op die eiendom te wees: 'n Losstaande enkelverdieping woning bestaande uit:

3 (Drie) Slaapkamers, 2 (Twee) Badkamers, 1 (Een) Kombuis, gebou van steen onder 'n sinkdak, Volvloermatte, Garage bediendekamer met gewone buit buitegeboue, woonstel met motorafdak.

4. *Voorwaardes van Verkoop*

Die Voorwaardes van Verkoop in Eksekusie mag gedurende kantoorure by die kantoor van die Bode van die Hof, Eggo Janstraat 42, Oberholzer, 2502 nagesien word.

Gedateer te Klerksdorp hierdie 15de dag van September 1987.

(Get) Charl du Plooy, vir J. J. Oosthuizen, Du Plooy & Vennote, 1ste Vloer, SA-Perm Gebou, Boomstraat, Posbus 22, Klerksdorp, 2570.

En p/a Laage Schoeman & Stadler, Fluorspar 2, Fluorsparstraat, Posbus 854, Carletonville, 2500.

Case 2788/87

IN THE MAGISTRATE'S COURT FOR THE DISTRICT OF BRAKPAN HELD AT BRAKPAN

In the matter between **Allied Building Society**, Plaintiff, and **J. B. du Toit**, 1st Defendant, **C. du Toit**, 2nd Defendant

In pursuance of a Judgment in the Court of the Magistrate of Brakpan and Writ of Execution dated the 3rd day of July 1987, the property listed hereunder will be sold in Execution on the 6th day of November 1987, at 11 a.m. at the premises of the Messenger of the Court, 439 Prince George Avenue, Brakpan to the highest bidder:

Certain:

Erf 1320 Leachville Extension 1 Township, Registration Division I R Transvaal.

Measuring 600 (Six Hundred) Square Metres.

Held by Deed of Transfer No.: T 37037/1986.

The Property is defined as a residential stand, situated at 14 Winterberg Street, Grenelefe, Brakpan.

No warrant or undertaking is given in relation to the nature of the improvements, which are described as follows:

Main Building: 1 Lounge, 1 Dining Room, 1 Bathroom plus Toilet, 1 Kitchen, 3 Bedrooms, Plastered Walls under Tile Roof.

Outbuildings: Single Garage, Walled Fencing.

The material conditions of sale are:

- a) The sale will be held by Public Auction and without reserve and will be "voetstoots".
- b) Immediately after the sale the Purchaser shall sign the Conditions of Sale which can be inspected at the Messenger of the Court's office, Brakpan.
- c) The purchaser shall pay all amounts necessary to obtain transfer of the property, including all costs of transfer, transfer duty, rates, taxes, licenses, sanitary fees, interest etc.
- d) The purchase price shall be paid as to 10% (Ten per cent) thereof or R500,00 (Five hundred rand) whichever is the greater, on the day of the sale and the unpaid balance, together with interest on the full amount of the Judgment Creditor's claim at the rate specified in the full conditions of sale to date of payment, within fourteen days to be paid or secured by a Bank or Building Society guaranteed.
- e) The property shall be sold subject to any existing tenancy.
- f) Failing compliance with the provisions of the conditions of Sale, the Purchaser shall forfeit for the benefit of the Execution Creditor the deposit referred to in (d) above, without prejudice to any claim against him for damages.

The full Conditions of Sale may be inspected at the Offices of the Messenger of the Court.

Dated at Brakpan on this 14th day of September 1987.

(Sgd) P. J. Cowling, for Trollip, Joubert, Cowling & Janeke, 125A Kingsway Avenue, P.O. Box 38, Brakpan. Tel: 55-8363.

Saak 2842/87

IN DIE LANDDROSHOF VIR DIE DISTRIK MIDDELBURG GEHOU TE MIDDELBURG

Tussen **Allied Bouvereniging**, Eiser, en **B. J. Kriel**, Verweerder

Ingevolge uitspraak in die Hof van die Landdros van Middelburg en Lasbrief tot Geregtelike verkoping gedateer die 27ste dag van Augustus 1987 sal die ondervermelde goedere op Vrydag die 30ste dag van Oktober 1987 om 12h30, te Landdroshof, Markstraat, Middelburg, 1050 aan die hoogste bieder geregtelik verkoop word, naamlik:

Erf: 2870 geleë in die dorp Middelburg, Uitbreiding 10, Registrasie Afdeling J.S., Transvaal.

Groot: 1 128 (Eenduisend Eenhonderd Agt-en-Twintig) vierkante meter;

Gehou: Kragtens Akte van Transport T 12893/85 onderhewig aan sodanige voorwaardes soos in genoemde akte vermeld staan of na verwys word insluitend die voorbehoud van regte tot minerale;

Geleë: Te Palmstraat 20, Middelburg, 1050.

Verkoopsvoorwaardes:

1. 'n Deposito van 10 % (Tien per centum) van die koopprys op datum van verkoping met goedgekeurde bank/bouverenigings waarborge vir die balans koopprys binne 45 (vyf-en-veertig) dae na datum van verkoping;
2. Verdere voorwaardes is beskikbaar by die kantore van die plaaslike Geregsbode en by Esterhuysen Botha & Van der Walt Prokureur, Markstraat 20B, Middelburg, Transvaal, 1050.

(Get) P. J. van der Walt, vir Esterhuysen Botha & Van der Walt.

Saak 3126/87

IN DIE LANDDROSHOF VIR DIE DISTRIK VAN BENONI GEHOU TE BENONI

In die saak tussen **Die Trust Bank van Afrika Beperk**, Eiser, en **D. C. Swart**, Eerste Verweerder, **H. A. Swart**, Tweede Verweerder

Kragtens 'n vonnis in die Landdroshof van Benoni en 'n Lasbrief vir Eksekusie gedateer 21 Mei 1987, word die ondergenoemde eiendom op Woensdag 4 November 1987 om 11h00 te Landdroskantoor, Harpurlaan, Benoni geregtelik aan die hoogste bieder verkoop:

Hoewe 312 Benoni Agricultural Holdings, Registrasieafdeling I.R. Transvaal.

Groot 2,1146 (twee komma een een vier ses) hektar welke eiendom bestaan uit:

Woonhuis met siersteenmure en platdak bestaande uit 3 slaapkamers, 1 badkamer, 1 sitkamer, 1 kombuis en buitegeboue bestaande uit bediende kamer met toilet en motoraafdak.

Die wesentlike voorwaardes van die veiling is:

1. Die veiling sal sonder voorbehoud in die openbaar geskied en is voetstoots.
2. Die Koper sal onmiddellik na die veiling die verkoopsvoorwaardes, wat in die kantoor van die Geregsbode, Princeslaan 28, Benoni ter insae lê, teken.
3. Die Koper sal die nodige bedrae betaal om oordrag van die eiendom te verkry. Dit sluit in: Alle oordragkoste, oordragbelasting, belasting, munisipale belasting, lisensie, sanitere fooie, rente ens.
4. Die koopprys sal soos volg betaal word: 20 % (twintig persent) daarvan op R300,00 (watter een ook al die grootste is) op die dag van die veiling en die balans, met rente op die volle bedrag van die vonniseiser se eis tot op die dag van betaling, binne 14 (veertien) dae by wyse van 'n bank- of bouverenigingwaarborg gelewer.
5. Die eiendom is onderhewig aan enige bestaande huurkontrak.
6. Sou die Koper in gebreke bly om aan die verkoopsvoorwaardes te voldoen, sal hy die deposito, waarna in (4) hierbo verwys word, ten gunste van die vonniseiser verbeur, sonder voorbehoud van enige skadevergoedingseis teen hom.

Gedateer te Benoni hierdie 22ste September 1987.

(Get) J. W. A. van Wyk, vir Du Plessis, De Heus & Van Wyk, Marilest Gebou, Eerste Vloer, Woburnlaan 72, Benoni. Verw. Mnr van Wyk/sp.

IN THE SUPREME COURT OF SOUTH AFRICA
(Transvaal Provincial Division)

In the matter between **Barclays National Bank Limited**, Plaintiff, and **Daniël Gerhardus van den Heever**, Defendant

In terms of a judgment of the Supreme Court of South Africa (Transvaal Provincial Division) and writ dated 5 November 1986 in the above matter, a sale by public auction without a reserve price will be held by the deputy sheriff, Potgietersrus in front of the Magistrate's Court, Hooge Street, Potgietersrus, on Friday, 6 November 1987 at 10h00 upon conditions which may now be inspected at the offices of the deputy sheriff, at 1st Floor, Santambank Centre, 80 Voortrekker Road, Potgietersrus and which will be read by him at the time of the sale, of the following property owned by defendant:

The farm Kwarriepoort 226, registration division L.R., Transvaal;

Measuring: 1390,7824 hectares;

Held by Daniël Gerhardus van den Heever (identity number: 5112025077007) under deed of transfer No. T23092/1986.

The following improvements are on the property:

A farm house, a store, a shed. The property is fenced with game-proof fencing. The property is divided into eight camps with water points in each camp. There are two boreholes with pumps. There is 100 hectares of dry land.

No guarantee is given as to the nature and extent of the property or as to the improvements on the property.

Terms:

Ten per centum (10%) of the purchase price and auctioneer's charges in cash on the day of the sale, the balance against transfer to be secured by a bank or building society or other acceptable guarantee to be furnished to the deputy sheriff within fourteen (14) days from the date of sale.

R. M. Brink, for Rooth & Wessels, Attorney for Plaintiff, Barclays Bank Building, Church Square, Pretoria. (Tel: (012) 3252940.)

Case 5825/87

IN THE SUPREME COURT OF SOUTH AFRICA
(Witwatersrand Local Division)

In the matter between **Fidelity Bank Limited**, Plaintiff, and **Jan Bastiaan Spanner**, Defendant

In Execution of a Judgment of the Supreme Court of South Africa (Witwatersrand Local Division) in the above-mentioned suit, a sale with a reserve price of R144 000,00 will be held in front of the Magistrate's Court of Tzaneen, Morgan Street, Tzaneen on 30 October 1987 at 10h00 of the undermentioned property of the Defendant on the conditions to be read out by the Auctioneer at the time of the sale which conditions will lie for inspection at the offices of the Deputy Sheriff, Cor Danie Joubert and Agatha Streets, Tzaneen prior to the sale.

Ptn 43 (a Ptn of Ptn 42) of the Farm Hasivona No. 561.

The following information is furnished *re* the improvements, though in this respect nothing is guaranteed:

Dwelling house and usual outbuildings.

Terms: 10% (tne per centum) of the purchase price in cash on the day of the sale, the balance payable against registration of transfer, to be secured by a bank or building society or other acceptable guarantee to be furnished within 14 (fourteen) days from the date of sale. Auctioneers charges, payable on the day of sale, to be calculated as follows: 5 % (five per centum) on the proceeds of the sale up to a price of R10 000,00 (ten thousand Rand) and thereafter 2½% (two and a half per centum) up to maximum of R5 000,00 (five thousand rand). Minimum charges R30,00 (thirty Rand).

Dated at Johannesburg on this 23rd Day of September 1987.

Salomon-Friedman, Attorneys for Plaintiff, 1st and 2nd Floor, SFB Chambers, Cor Marshall and Von Brandis Sts., Johannesburg. (Ref.: J. F. Bezuidenhout), Tel. 331-0312.

Saak 3231/87

IN DIE LANDDROSHOF VIR DIE DISTRIK VAN RUSTENBURG GEHOU TE RUSTENBURG

In die saak tussen **S A Permanente Bouvereniging**, Eiser, en **L. P. A. Spies**, Verweerder

Ingevolge uitspraak van die Landdros van Rustenburg en Lasbrief tot Geregtelike Verkoop met datum die 2de September 1987 sal die ondervermelde eiendom op Vrydag, 30 Oktober 1987 om 10.30 v.m. voor die Landdroskantoor Rustenburg aan die hoogste bieder geregtelike verkoop word naamlik:

Erf 879 in die dorp Geelhoutpark Uitbreiding 4, Rustenburg, Registrasie Afdeling J.Q. Transvaal.

Groot: 744 (Sewe Vier Vier) Vierkante Meter;

Gehou kragtens Akte van Transport No. 15202/87.

Geleë te Lekkerbreekweg 67, Geelhoutpark, Uitbreiding 4, Rustenburg waarop opgerig is een woonhuis van baksteenmure onder grasdak wat gesê word vier Kamers, buiten kombuis en een badkamer en gewone buitegeboue bestaande uit een motorhuis, te bevat ten opsigte waarvan egter geen waarborg gegee word nie.

Voorwaardes:

10 (Tien Persent) van die koopsom in kontant op die dag van die verkoop en die balans teen registrasie van transport, verseker te wees deur 'n goedgekeurde Bank of Bouvereniging se waarborg gelewer te word binne 21 (Een en Twintig) dae. Die eiendom word voetstoots onderhewig aan enige bewoningsreg.

Die volledige voorwaardes van verkoop (wat na die verkoop geteken moet word) mag gedurende kantoor-ure by die Kantoor van die Geregsbode, Smitslaan, Rustenburg nagesien word.

Die Eiser is bereid om 'n verband aan 'n goedgekeurde Koper toe te staan.

Immelman Visagie & Van der Merwe, Prokureurs vir Eiser, H/v Van Staden- en Bergstraat, Posbus 673, Rustenburg, 0300. Verw: Mnr. Visagie/cl.

Saak 8689/86

IN DIE LANDDROSHOF VIR DIE DISTRIK VAN SPRINGS GEHOU TE SPRINGS

In die saak tussen **E. P. Bouvereniging**, Eiser, en **D. L. Pinnoy**, Verweerder

Geliewe kennis te neem dat ingevolge uitspraak van bogenoemde agbare Hof gedateer 2 Desember 1986 en daaropvolgende Lasbrief vir Eksekusie die hiernagenoemde eiendom om 10h00 op 27 Oktober 1987 te die Landdros Hof Presidentstraat, Germiston geregtelik verkoop sal word, naamlik:

Erf 648, Elsburg Uitbreiding 1.

Groot: 991 (Negehonderd Een en Negentig) vierkante meter;

Gehou: Onder Titellakte T9317/86.

Ek neem verder kennis dat die verkoopsvoorwaardes by die kantore van die Geregsbode Germiston ter insae lê en behels o.a. die volgende:

1. Tien persent van koopsom op datum van veiling.
2. Balans koopsom, plus rente binne 14 dae vanaf datum van veiling.
3. Besit onderhewig aan enige huurkontrak.

Gedateer te Springs op hede die 4de September 1987.

(Get.) J. D. Dippenaar, vir Dippenaar & Kie., 5de Vloer, E.P. Gebou, h/v 3de Straat en 4de Laan, Springs.

Saak 465/87

IN DIE LANDDROSHOF VIR DIE DISTRIK VAN WARMBAD GEHOU TE WARMBAD

In die saak tussen **Stadsraad van Warmbad**, Eiser, en **Eson (Edms.) Beperk**, Verweerder

Ingevolge uitspraak van bogenoemde Agbare Hof en 'n Lasbrief tot Eksekusie gedateer 23 Julie 1987 sal hierdie ondervermelde eiendom geregtelik verkoop word op Donderdag, 29 Oktober 1987 om 10h00 voormiddag voor die Landdroskantoor, Warmbad aan die persoon wie die hoogste aanbod maak, nl.:

Erf 457 geleë in die dorp Warmbaths, Registrasie Afdeling K.R., Transvaal.

Groot: 1 631 (Een Ses Drie Een) Vierkante Meter.

Gehou kragtens Akte van Transport No. T35748/1980; onderhewig aan al sodanige voorwaardes as wat in gemelde akte vermeld staan of na verwys word.

Die Verkoopsvoorwaardes, wat onmiddellik voor die verkoping gelees sal word, lê ter insae in die kantoor van die Geregsbode, Warmbad. Die belangrikste voorwaardes daarin vervat is die volgende:

Dat die eiendom vir kontant en aan die hoogste bieder verkoop sal word onderworpe aan die regte van die Verbandhouders soos uiteengesit in die Verkoopsvoorwaardes wat ter insae lê by die kantore van die Geregsbode, Warmbad.

Geteken te Warmbad op hede die 21ste dag van September 1987.

(Get.) J. Koorts, vir Herman & Oberholzer, Prokureur vir Eiser, Paratusgebou, Pretoriaweg 2, Posbus 106, Warmbad, 0480.

Saak 2784/87

IN DIE LANDDROSHOF VIR DIE DISTRIK VAN MIDDELBURG GEHOU TE MIDDELBURG

Die Trust Bouvereniging, Eiser, en **Jan Paul van Vollenhoven**, Verweerder

Ooreenkomstig van 'n Vonnis van die Landdros in bogemelde Agbare Hof en 'n Lasbrief tot Uitwinning gedateer 7 September 1987 sal die ondergenoemde eiendom as 'n eenheid op Vrydag 6 November 1987 om 10h00 op die trappe voor die Landdroskantoor, Middelburg, per publieke veiling verkoop word:

Erf Resterende gedeelte van erf 654 geleë in die dorp Middelburg, Registrasie Afdeling J S, Transvaal;

Groot 1 902 vierkante meter;

Gehou kragtens Akte van Transport T27211/83.

Hierdie eiendom sluit in: Woonhuis met buitegeboue.

Die Wesentlike Voorwaardes van Verkoop is:

i) Die eiendom sal "voetstoots" aan die hoogste bieder sonder 'n reserweprys verkoop word.

ii) Die koopprijs sal betaal word teen 10% (Tien Persent) daarvan op die dag van die verkoping en die balans verskuldig, tesame met rente op die totale bedrag van die Skuldeiser se eis, teen 14% (Veertien Persent) per jaar vanaf 24 Julie 1987 tot datum van betaling, sal betaal of verseker word deur 'n Bank- en/of Bougenootskapswaarborg binne 14 (Veertien) dae datum van verkoping.

iii) Die Koper sal binne 14 (Veertien) dae vanaf datum van alle agterstallige belastings aan die Plaaslike Owerheid of aan enige ander persoon of persone wat daarop geregtig is, betaal om oordrag van die eiendom te verseker, en sal ook onmiddellik alle transportkoste, hereregte, lisensies sanitêre gelde, en rente en enige ander uitgawes aan die Eiser se prokureurs betaal om oordrag van die eiendom te verkry.

iv) Die eiendom sal verkoop word onderhewig aan enige bestaande huurtermyn.

Die volledige verkoopsvoorwaardes kan nagesien word in die kantoor van die Geregsbode, Middelburg.

Gedateer te Middelburg hierdie 23ste dag van September 1987.

(Get.) H. P. Campher, vir Van Deventer Rousseau & Campher, Markstraat 22, Posbus 2125, Middelburg. Tel: 25204. Verw: Mnr. Campher/av/T186.

Case 9080/87

IN THE MAGISTRATE'S COURT FOR THE DISTRICT OF JOHANNESBURG HELD AT JOHANNESBURG

In the matter between **Denver Finance (Pty) Limited**, Plaintiff, and **P. J. & H. S. Kleynhans**, Defendant

In pursuance of a Judgment in the Court of the Magistrate of Johannesburg and a Warrant of Execution dated the 6th day of May 1987, the following property will be sold in execution on the 9th day of November 1987 at 11.00 a.m. at the Magistrates Court, Pretorius Street, Pretoria, to the highest bidder:

Certain: 2337 Danville.

Measuring: 674 square metres.

Known as: 81 Delaney Street, Danville.

Conditions of Sale

1. The property shall be sold without reserve and to the highest bidder and shall be subject to the terms and conditions of the Magistrate's Court Act and the Rules made thereunder, and of the title deeds, in so far as these are applicable.

2. The following improvements on the property have been reported, but nothing is guaranteed:

A dwelling house with the usual outbuildings.

Zoned special residential, White Group Area.

3. *Terms:* The Purchase price shall be paid as to ten per centum (10%) thereof on the signing of the Conditions of Sale and the unpaid balance together with interest thereon at the rate stipulated in the 1st Mortgage Bond registered against the property to date of payment, within fourteen (14) days to be paid or secured by an approved Bank or Building Society guarantee.

4. *Conditions:* The full Conditions of Sale which will be read by the Messenger of the Court, Pretoria immediately prior to the sale, may be inspected at his office, Pretoria and at the offices of Messrs Bredell Murray & Ronbeck, 17th Floor, Kine Centre, Commissioner Street, Johannesburg.

Dated at Johannesburg on this the 23rd day of September 1987.

(Sgd) E. A. Ronbeck, for Bredell Murray & Ronbeck, Plaintiff's Attorneys, 17th Floor, Kine Centre, Commissioner Street, Johannesburg.

Case 25146/87

IN THE MAGISTRATE'S COURT FOR THE DISTRICT OF JOHANNESBURG HELD AT JOHANNESBURG

In the matter between **Denver Finance (Pty) Limited**, Plaintiff, and **Richard Carl van den Heever**, Defendant

In pursuance of a Judgment in the Court of the Magistrate of Johannesburg and a Warrant of Execution dated the 8th day of June 1987, the following property will be sold in execution on the 4th day of November 1987 at 10h00 at Biccard Street Entrance, Krugersdorp (in front of the Magistrate's Court) to the highest bidder:

Certain: Erf: Portion 498 of Erf: 251 Krugersdorp.

Measuring: 500 square metres.

Known as: 9 Die Laan, Krugersdorp North.

Conditions of Sale

1. The property shall be sold without reserve and to the highest bidder and shall be subject to the terms and conditions of the Magistrate's Court Act and the Rules made thereunder, and the title deeds, in so far as these are applicable.

2. The following improvements on the property have been reported, but nothing is guaranteed:

A dwelling house with usual outbuildings.

Zoned special residential, White Group Area.

3. *Terms:* The Purchase price shall be paid as to ten per centum (10%) thereof on the signing of the Conditions of Sale and the unpaid balance together with interest thereon at the rate stipulated in the 1st Mortgage Bond registered against the property to date of payment, within fourteen (14) days to be paid or secured by an approved Bank or Building Society guarantee.

4. *Conditions:* The full Conditions of Sale which will be read by the Messenger of the Court, Krugersdorp immediately prior to the sale, may be inspected at his office, Krugersdorp and at the offices of Messrs Bredell Murray & Ronbeck, 17th Floor Kine Centre, Commissioner Street, Johannesburg.

Dated at Johannesburg on this 23rd day of September 1987.

(Sgd) E. A. Ronbeck, for Bredell Murray & Ronbeck, Plaintiff's Attorney, 17th Floor, Kine Centre, 141 Commissioner Street, Johannesburg.

Saak 3749/86

LANDDROSHOF KLERKSDROP

United Bouvereniging Beperk, Eiser, en **Roelof Gert van Rooyen**, Eerste Verweerder, **Maria Johanna van Rooyen**, Tweede Verweerder

As gevolg van 'n vonnis van die Landdroshof Klerksdorp en 'n lasbrief van eksekusie gedateer die 12de Mei 1987 sal die volgende eiendom in eksekusie verkoop word op Vrydag die 30ste Oktober 1987 om 10h00 by die eiendom, naamlik Kiplingstraat 1, Orkney.

Erf 998, geleë in die dorp Orkney, Registrasie Afdeling I.P., Transvaal;

Groot: 1 016 (Eenduisend en Sestien) vierkante meter;

Verkoopsvoorwaardes:

1. Die gesegde eiendom sal verkoop word sonder voorbehoud aan die hoogste bieder en die verkoping sal onderhewig wees aan die bepalinge van die Landdroshowewet en reëls daarvolgens neergelê en die voorwaardes van die akte van transport asook die verkoopsvoorwaardes waarna verwys word in paragraaf 4 hiervan.

2. Sonder om dit enigins te waarborg is die eiendom verbeter met woonhuis bestaande uit:

Portaal, sitkamer, eetkamer, drie slaapkamers, 1 badkamer, 1 toilet, kombuis en buitegeboue bestaande uit 'n enkel motorhuis, bediendekamer en toilet.

3. Die koopprijs is betaalbaar soos volg:

10% van die koopprijs op die verkoping en die balans moet betaal of gewaarborg word met 'n goedgekeurde bank- of bougenootskapwaarborg binne veertien (14) dae vanaf datum van koop.

4. Die volledige verkoopsvoorwaardes sal deur die Geregsbode van hierdie Agbare Hof uitgelees word voor die verkoping en lê ook ter insae by sy kantore en die kantoor van die Eise se prokureurs.

O.P.B. L'ange, vir L'ange, De Waal & Freysen, Eerste Verdieping, Ferum Huis, Kockstraat 22, Posbus 59, Klerksdorp.

Case 7059/87

IN THE SUPREME COURT OF SOUTH AFRICA

(Witwatersrand Local Division)

In the matter between **South African Permanent Building Society**, Plaintiff, and **Frederick Brooker**, Defendant

In execution of a Judgment of the Supreme Court of South Africa (Witwatersrand Local Division) in this suit, a sale without reserve will be held at the office of the Deputy Sheriff, 131 Marshall Street, Johannesburg at 10h00 on 5th November 1987 in the forenoon, of the undermentioned property of the Defendant on Conditions to be read out by the Auctioneer at the time of the sale and which may be inspected at the office of the Deputy Sheriff prior to the sale.

Certain: Erf 21 Ormonde Extension No. 1 Township, Registration Division I.Q., Transvaal;

Situation: 29 Essen Road, Ormonde;
Area: 648 (six hundred and forty eight) square metres;
Improvement (not guaranteed): A house under tiled roof, consisting of six rooms, two bathrooms, fitted carpets and slate floors, two garages, servants quarter and toilet and brick wall surrounding property.

Terms: 10% of the purchase price in cash on the day of the sale; the balance and interest on the full purchase price at current bond rates payable against registration of transfer, to be secured by a bank, building society or other acceptable guarantee to be furnished within 14 (fourteen) days from the date of sale. Auctioneer's charges are payable on the day of the sale and calculated at 5% on the proceeds of the sale up to a price of R10 000,00 and thereafter 2½%, to a maximum fee of R5 000,00 and a minimum of R30,00.

Dated at Johannesburg on this the 22nd day of September 1987.

Sgd. A. Lowndes, for Smith & Lowndes, Plaintiff's Attorneys, 10th Floor, S A Centre, 253 Bree Street, P.O. Box 8274, Johannesburg. Tel: 337-6015. Ref: Mr Lowndes/SAP103.AGL.

Case 17033/87

IN THE SUPREME COURT OF SOUTH AFRICA
 (Witwatersrand Local Division)

In the matter between **South African Permanent Building Society**, Plaintiff, and **Margaret Norman Marescia**, Defendant

In execution of a Judgment of the Supreme Court of South Africa (Witwatersrand Local Division) in this suit, a sale without reserve will be held at the office of the Deputy Sheriff, Johannesburg, 131 Marshall Street, Johannesburg at 10h00 on 5th November 1987 in the forenoon, of the undermentioned property of the Defendant on Conditions to be read out by the Auctioneer at the time of the sale and which may be inspected at the office of the Deputy Sheriff prior to the sale.

Certain: Erf 3615 Eldoradopark Extension 2 Township, Registration Division I.Q., Transvaal;

Situation: 18 Nieuveld Street, Eldoradopark Extension 2;

Area: 330 (three hundred and thirty) square metres;

Improvements (not guaranteed): A house under tiled roof, consisting of three bedrooms, lounge, diningroom, one bathroom and separate toilet, fitted carpets, single garage and retaining wall.

Terms: 10% of the purchase price in cash on the day of the sale; the balance and interest on the full purchase price at current bond rates payable against registration of transfer, to be secured by a bank, building society or other acceptable guarantee to be furnished within 14 (fourteen) days from the date of sale. Auctioneer's charges are payable on the day of the sale and calculated at 5% on the proceeds of the sale up to a price of R10 000,00 and thereafter 2½%, to a maximum fee of R5 000,00 and a minimum of R30,00.

Dated at Johannesburg on this the 22nd day of September 1987.

Sgd. A. Lowndes, for Smit & Lowndes, Plaintiff's Attorneys, 10th Floor, S A Centre, 253 Bree Street, P.O. Box 8274, Johannesburg. Tel: 337-6015. Ref: Mr Lowndes/SAP103.AGL.

Saak 7456/85

IN DIE LANDDROSHOF VIR DIE DISTRIK VAN VANDERBIJLPARK GEHOU TE VANDERBIJLPARK

In die saak tussen **United Bouvereniging**, Eksekusieskuldeiser, en **Mnr P. C. Volschenk**, Eksekusieskuldenaar

Ingevolge 'n Vonnis van die Landdroshof vir die distrik van Vanderbijlpark gedateer die 26ste November 1985 en 'n Lasbrief vir Eksekusie uitgereik die 26ste November 1985 sal die volgende eiendom in eksekusie verkoop word op Vrydag die 30ste Oktober 1987 om 10h00 te Landdroshof gebou, Vanderbijlpark.

Sekere

Erf 854, Vanderbijlpark South West 5, Uitbreiding 2 Dorpsgebied, Registrasie Afdeling I.Q. Transvaal; Groot: 1 257 (Een Duisend Twee Honderd Sewe en Vyftig) vierkante meter; Gehou kragtens Akte van Transport No. T 42649/83; Onderhewig aan die voorwaardes daarin vermeld maar meer spesifiek die voorbehoud van Minerale Regte. (Ook bekend as Gounodstraat 13, Vanderbijlpark.)

Die gebied beskryf is vir okkupasie deur lede van die Wit groep alleenlik.

Die eiendom word verkoop onderhewig aan die bepalings van die Groepsgebiedewet en 10% (Tien Persent) van die koopprys is betaalbaar by sluiting van die Kooporeenkoms en die balans teen registrasie van Transport aan die Koper, moet verseker word deur 'n aanvaarbare waarborg wat aan die Geregsbode voorsien moet word binne 14 (Veertien) dae vanaf datum van verkoping. Die verkoping is onderhewig aan Artikel 66 van die Wet op Landdroshowe No. 32 van 1944 soos gewysig. Die volle voorwaardes van die eksekusieverkoping wat op die Koper bindend sal wees, sal voor die verkoping uitgelees word en kan gedurende kantoorure nagegaan word by die kantoor van die Geregsbode, Vanderbijlpark en by die kantore van Eiser se Prokureurs.

Geteken te Vanderbijlpark hierdie 22ste dag van September 1987.

Raubenheimer Theron & Ferreira, Prokurerus vir Eiser, Unitedgebou 1, Eric Louwstraat, Posbus 581, Vanderbijlpark, 1900.

Saak 19112/1985

IN DIE HOOGGEREGSHOF VAN SUID-AFRIKA

(Transvaalse Provinsiale Afdeling)

In die saak tussen **J. A. C. Nel**, Eiser, en **C. J. van Heyde**, Verweerder

Ingevolge 'n uitspraak van bogenoemde Hof op 31 Maart 1987 en Lasbrief tot Eksekusie in terme daarvan, sal die Adjunk-Balju, Rustenburg op 6 November 1987 om 10h00 by die Landdroskantoor, h/v Van Staden- en Klopperstraat, Rustenburg verkoop die ondergenoemde onroerende eiendom met verbeterings daarop soos aangedui hierin en op die voorwaardes wat uitgelees sal word deur die Adjunk-Balju, Rustenburg:

Gedeelte 75 ('n Gedeelte van Gedeelte 14) van die plaas Boekenhoutfontein 260, Registrasie Afdeling JQ, Transvaal;

Groot: Een-en-twintig komma vier een drie drie (21,4133) hektaar;

Gehou onder Akte van Transport No. 34271/82.

Verbeterings: Vier Slaapkamerhuis met sinkdak; twee badkamers, twee toilette, eetkamer, sitkamer, televisiekamer, twee sementdamme, boord onder besproëing, twee werksnemershuisse, warmwaterstelsel; koeistal vir tien koeie; twee opgaar varswaterhouers elk van 20 000 liter; elektriese buiteligte; dubbel motorhuis en staanplek vir karavaan; vrugte-pakkamer; afdak vir trekker en twee vragmotors en 'n bakkie; 8 hondehokke; grasdak-somerhuisie; 5 morge groentetuin met ondergrondse besproëing; drukgang vir vee; twee boorgate; bo-grondse besproëing vir 7 000 sitrusbome; huis omhein met doringdraad; drie veekampe wat verdeel is; 242 Defystoof; 10 liter vrieskas; volvloermatter in huis.

Voorwaardes:

Enige koper moet 'n deposito van 10% van die koopprys en die Adjunk-Baljufoeie betaal op die dag van die verkoping, die balans betaal te word teen transport en verseker te word deur 'n waarborg van 'n bank- of 'n bouvereniging wat deur die Eiser se prokureurs goedgekeur word, die waarborg aan die Adjunk-Balju binne 30 dae na datum van verkoping verstrekt te word. Geen waarborg word verskaf in verband met enige verbeterings op die eiendom nie.

Geteken te Pretoria hierdie 24ste dag van September 1987.

A. de W. Horak, vir Couzyn, Hertzog & Horak Ing., Eiser se Prokureurs, Trust Bank Sentrum, Sentraalstraat, Pretoria. Verw.: Mnr. Horak/pc.

Case 3491/87

IN THE MAGISTRATE'S COURT FOR THE DISTRICT OF BRAKPAN HELD AT BRAKPAN

In the matter between **Allied Building Society**, Plaintiff, and **P. J. Viljoen**, Defendant

In pursuance of a Judgement in the Court of the Magistrate of Brakpan and Writ of Execution dated the 21st day of July, 1987, the property listed hereunder will be sold in Execution on the 6th day of November, 1987, at 11 a.m. at the premises of the Messenger of the Court, 439 Prince George Avenue, Brakpan to the highest bidder:

Certain: Erf 163 Brakpan Noord Township Registration Division I R Transvaal;

Measuring: 888 (eight hundred and eighty eight) square metres.

Held by Deed of Transfer No: T29649/1984.

The Property is defined as a residential stand, situated at I Proctor Crescent, Brakpan North, Brakpan.

No warrant or undertaking is given in relation to the nature of the improvements, which are described as follows:

Main Building: brick/plaster walls, tiled roof, lounge, diningroom, three bedrooms, two bathrooms, kitchen.

Outbuildings: Double garage, one toilet, precast walling, paved drive-way.

The material conditions of sale are:

- a) The sale will be held by Public Auction and without reserve and will be "voetstoots".
- b) Immediately after the sale the Purchaser shall sign the Conditions of Sale which can be inspected at the Messenger of the Court's Office, Brakpan.
- c) The purchaser shall pay all amounts necessary to obtain transfer of the property, including all costs of transfer, transfer duty, rates, taxes, licenses, sanitary fees, interest etc.
- d) The purchase price shall be paid as to 10% (Ten per cent) thereof or R500,00 (Five hundred rand) whichever is the greater, on the day of the sale and the unpaid balance, together with interest on the full amount of the Judgment Creditor's claim at the rate specified in the full conditions of sale to date of payment, within fourteen days to be paid or secured by a Bank or Building Society guarantee.
- e) The property shall be sold subject to any existing tenancy.
- f) Failing compliance with the provisions of the conditions of Sale, the Purchaser shall forfeit for the benefit of the Execution Creditor the deposit referred to in (d) above, without prejudice to any claim against him for damages.

The full Conditions of Sale may be inspected at the Offices of the Messenger of the Court.

Dated at Brakpan on this 17th day of September 1987.

(Sgd) P. J. Cowling for Trollip, Joubert, Cowling & Janeke, 125A Kingsway Avenue, P.O. Box 38, Brakpan. Tel: 55-8363.

Case 3755/87

IN THE MAGISTRATE'S COURT FOR THE DISTRICT OF BRAKPAN HELD AT BRAKPAN

In the matter between **Allied Building Society**, Plaintiff, and **S. B. Berry**, Defendant

In pursuance of a Judgment in the Court of the Magistrate of Brakpan and Writ of Execution dated the 11th day of August 1987, the property listed hereunder will be sold in Execution on the 6th day of November, 1987, at 11 a.m. at the premises of the Messenger of the Court, 439 Prince George Avenue, Brakpan to the highest bidder:

Certain: Erf 1775 Dalpark Extension 6, Brakpan Registration Division I R Transvaal;

Measuring 1 343 (one thousand three hundred and forty three) square metres.

Held by Deed of Transfer No: T71/1985.

The Property is defined as a residential stand, situated at 18 Augrabies Avenue, Dalpark Extension 6, Brakpan.

No warrant or undertaking is given in relation to the nature of the improvements, which are described as follows:

Main Building: Brick/Plaster Walls under tiled Roof, Lounge, Diningroom, three bedrooms, bathroom plus two separate toilets, kitchen.

Outbuildings: Single Garage, Brick and Plaster Fencing.

The material conditions of sale are:

- a) The sale will be held by Public Auction and without reserve and will be "voetstoots".
- b) Immediately after the sale the Purchaser shall sign the Conditions of Sale which can be inspected at the Messenger of the Court's Office, Brakpan.
- c) The purchaser shall pay all amounts necessary to obtain transfer of the property, including all costs of transfer, transfer duty, rates, taxes, licenses, sanitary fees, interest etc.
- d) The purchase price shall be paid as to 10% (Ten per cent) thereof or R500,00 (Five hundred rand) whichever is the greater, on the day of the sale and the unpaid balance, together with interest on the full amount of the Judgment Creditor's claim at the rate specified in the full conditions of sale to date of payment, within fourteen days to be paid or secured by a Bank or Building Society guarantee.
- e) The property shall be sold subject to any existing tenancy.
- f) Failing compliance with the provisions of the conditions of Sale, the Purchaser shall forfeit for the benefit of the Execution Creditor the deposit referred to in (d) above, without prejudice to any claim against him for damages.

The full Conditions of Sale may be inspected at the Offices of the Messenger of the Court.

Dated at Brakpan on this 17th day of September, 1987.

(Sgd) P. J. Cowling for Trollip, Joubert, Cowling & Janeke, 125A Kingsway Avenue, P.O. Box 38, Brakpan. Tel: 55-8363.

IN THE SUPREME COURT OF SOUTH AFRICA
(Witwatersrand Local Division)

In the matter between **South African Permanent Building Society**, Plaintiff, and **Bazil Henry Joseph Varcoe**, Defendant

In execution of a Judgment of the Supreme Court of South Africa (Witwatersrand Local Division) in this suit, a sale without reserve will be held at the office of the Deputy Sheriff, Elna Randhof, cnr Selkirk Avenue and Blairgowrie Drive, Randburg at 10 o'clock on 3rd November 1987 in the forenoon, of the undermentioned property of the Defendant on Conditions to be read out by the Auctioneer at the time of the sale and which may be inspected at the office of the Deputy Sheriff prior to the sale.

Certain: Erf 3897 Bryanston Extension 3, Registration Division I.R., Transvaal;

Area: 2 858 square metres;

Situation: 11 Jacaranda Avenue, Bryanston Extension 3;

Improvements (not guaranteed): "A house under tiled roof consisting of 4 bedrooms (main en suite), 2 bathrooms, lounge, diningroom, family room, fitted carpets, 2 carports, servants quarters, servants bathroom, swimming pool with wire fencing around property".

Terms: 10% of the purchase price in cash on the day of the sale; the balance and interest on the full purchase price at current bond rates payable against registration of transfer, to be secured by a bank, building society or other acceptable guarantee to be furnished within 14 days from the date of sale. Auctioneer's charges are payable on the day of the sale and calculated at 5% on the proceeds of the sale up to a price of R10 000,00 and thereafter 2½%, to a maximum fee of R5 000,00 and a minimum of R30,00.

Dated at Johannesburg on 21st September 1987.

Sgd. S. E. van Zyl for E. F. K. Tucker Inc., Plaintiff's Attorneys, 48th Floor, Carlton Centre, Commissioner Street, Johannesburg. Tel: 331/7211.
Ref: Foreclosures/SAPE 7110-105.

Saak 2839/87

IN DIE LANDDROSHOF VIR DIE DISTRIK MIDDELBURG GEHOU TE MIDDELBURG

Tussen **Allied Bouvereniging**, Eiser, en **S. J. Smuts**, Verweerder

Ingevolge uitspraak in die Hof van die Landdros van Middelburg en Lasbrief tot Geregtelike verkoping gedateer die 27ste dag van Augustus 1987 sal die ondervermelde goedere op Vrydag die 30ste dag van Oktober 1987 om 11h30 te Landdroshof, Markstraat, Middelburg, 1050 aan die hoogste bieder geregtelik verkoop word, naamlik:

Gedeelte 1 van Erf 823 geleë in die dorp Middelburg, Registrasie Afdeling J.S., Transvaal;

Groot: 2 617 (tweeëuisend seeshonderd en sewentien) vierkante meter;

Gehou: Kragtens Akte van Transport T36061/86;

Geleë: te Hoogstraat 9A, Middelburg, 1050.

Verkoopsvoorwaardes:

1. 'n Deposito van 10% (Tien per centum) van die koopprijs op datum van verkoping met goedgekeurde bank/bouverenigings waarborge vir die balans koopprijs binne 45 (vyf-en-veertig) dae na datum van verkoping;

2. Verdere voorwaardes is beskikbaar by die kantore van die plaaslike Geregsbode en by Esterhuysen Botha & Van der Walt Prokureurs, Markstraat 20B, Middelburg, Transvaal, 1050.

(Get) P. J. van der Walt vir Esterhuysen Botha & Van der Walt.

Saak 2840/87

IN DIE LANDDROSHOF VIR DIE DISTRIK MIDDELBURG GEHOU TE MIDDELBURG

Tussen **Allied Bouvereniging**, Eiser, en **G. J. Smit**, Verweerder

Ingevolge uitspraak in die Hof van die Landdros van Middelburg en Lasbrief tot Geregtelike verkoping gedateer die 27ste dag van Augustus 1987 sal die ondervermelde goedere op Vrydag die 30ste dag van Oktober 1987 om 11h00 te Landdroshof, Markstraat, Middelburg, 1050 aan die hoogste bieder geregtelik verkoop word, naamlik:

Erf 2248 geleë in die dorp Middelburg, Uitbreiding 8, Registrasie Afdeling J.S., Transvaal;

Groot: 1 984 (eenduisend negehonderd vier-en-tagtig) vierkante meter;

Gehou: Kragtens Akte van Transport T83/1980;

Geleë: te Jan Cilliersstraat 74, Middelburg, 1050.

Verkoopsvoorwaardes:

1. 'n Deposito van 10% (Tien per centum) van die koopprijs op datum van verkoping met goedgekeurde bank/bouverenigings waarborge vir die balans koopprijs binne 45 (vyf-en-veertig) dae na datum van verkoping;

2. Verdere voorwaardes is beskikbaar by die kantore van die plaaslike Geregsbode en by Esterhuysen Botha & Van der Walt Prokureurs, Markstraat 20B, Middelburg, Transvaal, 1050.

(Get) P. J. van der Walt vir Esterhuysen Botha & Van der Walt.

Case 25741/86

IN THE SUPREME COURT OF SOUTH AFRICA

(Witwatersrand Local Division)

In the matter between **South African Permanent Building Society**, Plaintiff, and **Marcus Hendrik Maria Broers**, Defendant

In execution of a Judgment of the Supreme Court of South Africa (Witwatersrand Local Division) in this suit, a sale without reserve will be held at the office of the Deputy Sheriff, Magistrate's Office Westonaria at 10 o'clock on 6th November 1987 in the forenoon, of the undermentioned property of the Defendant on Conditions to be read out by the Auctioneer at the time of the sale and which may be inspected at the office of the Deputy Sheriff prior to the sale.

Certain: Holding 363 West Rand Agricultural Holdings Extension I Township;

Area: 2,0845 square metres;

Situation: Holding 363, Bruce Avenue, West Rand a/h Ext. 1 Zuurbekom;

Improvements (not guaranteed): "A house under corrugated iron roof, consisting of 3 bedrooms, 2 bathrooms, lounge, diningroom, familyroom, fitted carpets, swimmingpool and mesh wire around property".

Terms: 10% of the purchase price in cash on the day of the sale; the balance and interest on the full purchase price at current bond rates payable against registration of transfer, to be secured by a bank, building society or other acceptable guarantee to be furnished within 14 days from the date of sale. Auctioneer's charges are payable on the day of the sale and calculated at 5% on the proceeds of the sale up to a price of R 10 000,00 and thereafter 2½%, to a maximum fee of R5 000,00 and a minimum of R30,00.

Dated at Johannesburg on 14th September 1987.

Sgd. S. E. van Zyl for E. F. K. Tucker Inc., Plaintiff's Attorneys, 48th Floor, Carlton Centre, Commissioner Street, Johannesburg. Tel: 331-7211. Ref: Foreclosures/SAPE 7109-744.

Case 18196/85

IN THE SUPREME COURT OF SOUTH AFRICA
(Transvaal Provincial Division)

In the matter between **Automated Business Systems (Pty) Ltd**, Plaintiff, and **Demetrius Pieter Breet**, First Defendant and **Demetrius Breet**, Second Defendant

By virtue of a certain Writ of Execution issued out of the above Honourable Court the undermentioned property will be sold by public auction on Wednesday the 4th day of November 1987 at 10h00 at the office of the Deputy Sheriff, 142 Struben Street, Pretoria:

Certain Plot 84 Magaliesmoot Agricultural Holdings, Registration Division J R Transvaal (the improvements to the property consist of a brick house under tiles consisting of: 6 bedrooms, diningroom, 2 lounges, 2 kitchens, 3 bathrooms, 2 toilets, 4 servants quarters and 1 toilet. 2 garages and storeroom. No guarantee whatsoever is given in this regard);

Measuring 2,0234 hectares;

Held by Demetrius Pieter Breet under Deed of Transfer No. T31262/86.

The Conditions of Sale may be inspected at the office of the Deputy Sheriff, Pretoria, who will also furnish any other information required.

Dated at Pretoria this 24th day of September 1987.

Friedland Hart & Partners, Attorneys for Plaintiff, Van der Stel Building, Pretorius Street, Pretoria. Ref.: Mr Brauer/vc. Tel.: 26 3331 (012).

Saak 1604/1987

IN DIE LANDDROSHOF VIR DIE DISTRIK LETABA GEHOU TE TZANEEN

In die saak tussen **Nywerheid-Ontwikkelingskorporasie van Suid-Afrika Beperk**, Eiser, en **C M S M Knitwear (Edms) Beperk**, Verweerder

Uit kragte van 'n vonnis van die Landdros van Tzaneen en kragtens 'n Lasbrief vir eksekusie gedateer 16 Julie 1987 sal die volgende eiendom per publieke veiling op Vrydag 30 Oktober 1987 om 10h00 voor die Landdroskantoor Tzaneen te Morganstraat, aan die hoogste bieder verkoop word, naamlik:

Erf 352 geleë in die dorpsgebied Tzaneen Pusestraat 27 Uitbreiding 4 Tzaneen.

Groot 1 435 vierkante meter.

Vernaamste Verkoopvoorwaardes:

1. Die eiendom sal sonder reserwe en onderworpe aan die bepalings van die Wet op Landdroshowe en reëls daar kragtens aan die hoogste bieder verkoop word.

2. Die koper betaal 10% (Tien Persent) van die koopsom onmiddellik na die verkoping aan die Geregsbode en die balans word verseker by wyse van 'n bank- of bouvereniging waarborg, betaalbaar teen oordrag van die eiendom in die naam van die koper en wat afgelewer word by die eiser se prokureurs binne 14 (Veertien) dae na die datum van verkoping.

Voorwaardes van verkoop sal gedurende kantoorure by die kantoor van die Geregsbode, Eerstelaan 8 Tzaneen ter insae lê.

Get. A. E. Rech vir Joubert & May, Prokureur vir eiser, Rentmeestergebou, Posbus 35, Tzaneen.

Case 1604/1987

IN THE MAGISTRATE'S COURT FOR THE DISTRICT OF LETABA HELD AT TZANEEN

In the matter between **Nywerheid-Ontwikkelingskorporasie van Suid-Afrika Beperk**, Plaintiff, and **C M S M Knitwear (Edms) Beperk**, Defendant

In pursuance of judgment of the Court of the Magistrate of Tzaneen and Writ of Execution dated 16th July 1987 the following property will be sold by public auction on Friday 30th October 1987 at 10h00 in front of the Magistrate's Court, Morgan Street, Tzaneen to the highest bidder, viz:

Erf 352 Situate in the Township Tzaneen 27 Puse Street Extension 4 Tzaneen.

Measuring: 1 435 Square metres.

Material Conditions of Sale:

1. The property will be sold to the highest bidder without reserve and subject to the Magistrate's Court Act and Rules in terms thereof;

2. The purchaser shall pay 10% (Ten Per Cent) of the purchase price to the Messenger of the Court immediately after the sale and the balance shall be secured by means of Bank or Building Society guarantee, payable against registration of the property in the name of the purchaser, which guarantee shall be delivered to the plaintiff's attorneys within 14 (Fourteen) days of the date of sale.

The conditions of sale will lie for inspection during office hours at the offices of the Messenger of the Court, 8 First Avenue, Tzaneen.

Sgd A. E. Rech for Joubert & May, Rentmeester Building, Attorneys for plaintiff, Rentmeester Building, P.O. Box 35, Tzaneen.

Case 9394/86

IN THE MAGISTRATE'S COURT FOR THE DISTRICT OF BOKSBURG HELD AT BOKSBURG

In the matter between **Stabilitas Eksekuteurskamers (Pty) Limited**, Plaintiff Execution Creditor, and **Josias Hendrik Delpport**, Defendant Execution Debtor

Be pleased to take notice that a sale in execution in the above matter will take place on the 30th October 1987, at 11.15 a.m. at the main entrance Magistrate's Court, Adderley Street, Boksburg, which sale will be held by the Messenger of the Court, Boksburg, of the following immovable property:

Erf 398 Beyerspark Extension 3 Township Registration Division J R Transvaal situate at 21 Lucas Meyer Street, Beyerspark, Boksburg;

Measuring 763 square metres, comprising a dwelling-house with the usual outbuildings.

Terms and Conditions: 10% (ten per centum) of the purchase price to be paid on the date of the sale and the balance together with interest to be paid or secured by an approved Bank or Building Society guarantee within 14 days of the date of sale.

The complete Conditions of Sale may be inspected at the offices of the Messenger of the Court, Boksburg.

Dated at Boksburg on this the 16th day of September 1987.

Sgd H. M. Husted for Manfred Jacobs & Husted, 101 Nedbank Centre, Market Street, Boksburg. Tel: 52-7406. Ref: Mr Husted/ij.

Saak 1099/87

IN DIE LANDDROSHOF VIR DIE DISTRIK VAN LICHTENBURG GEHOU TE LICHTENBURG

Tussen **Stadsraad van Lichtenburg**, Eiser, en **S. W. Smit**, Verweerder

Ingevolge 'n uitspraak in die Hof van die Landdros te Lichtenburg en Laasbrief tot Geregtelike Verkoop gedateer 15 September 1987 word die ondervermelde eiendom om 10h00 op 6 November 1987 voor die Geregsbodekantoor, Kerkstraat 80, Lichtenburg geregtelik verkoop aan die persoon wie die hoogste aanbod maak:

Resterende Gedeelte van Erf 844 Lichtenburg vry van reserwe.

Die voorwaardes van verkoop sal ter insae wees by die Landdros, Lichtenburg en by ondergetekende en bepaal kortliks dat 10% van die koopprijs op die dag van die verkoping betaalbaar sal wees en die koopprijs tesame met rente daarop gereken word teen 10% per jaar vanaf datum van die verkoping tot datum van registrasie van transport van die eiendom ten name van die koper, gewaarborg moet word binne 14 dae vanaf datum van die verkoping, dat besit van die eiendom aan die Koper gegee sal word sodra gemelde balans koopprijs verseker is soos voormeld, dat die uitsluitlike risiko, wins en verlies ten opsigte van die eiendom by die Koper sal berus sodra die bod daarvoor op hom toegeslaan word, dat die Koper self sal moet reël vir okkupasie, dat die Koper verantwoordelik sal wees vir alle kostes, insluitende alle agterstallige belastinge en fooie en verkoopskommissie, dat die eiendom voetstoots verkoop word en dat alleen 'n lid van die Blanke Groep, soos omskryf in die Wet op Groepsgebiede No. 77 van 1957, soos gewysig, geregtig sal wees om die eiendom te koop.

(Get) J. J. Sauer vir Bosman & Bosman, Prokureur vir Eiser, Melvillestraat 45, Posbus 1, Lichtenburg, Verwysings 1127/87E.

Case 6862/87

IN THE MAGISTRATE'S COURT FOR THE DISTRICT OF JOHANNESBURG HELD AT JOHANNESBURG

In the matter between **Natal Building Society**, Plaintiff, and **Robert Mananga**, Defendant

In pursuance of a Judgment in the Court of the Magistrate, Johannesburg District Johannesburg, and Writ of Execution dated the 2nd March 1987 the following will be sold in execution on the 6th day of November 1987 at 10h00, Fox Street entrance of the Magistrate's Court Building, Johannesburg to the highest bidder:

The right of leasehold in site: 4315 Pimville Zone 4, Johannesburg.

In extent: known as: 4314 Pimville Zone 4, Johannesburg.

Conditions of sale:

1. The property shall be sold without reserve and to the highest bidder, and shall be subject to the terms and conditions of the Magistrate's Court Act and the Rules made thereunder, and of the title deeds in so far as these are applicable.

2. The following improvements on the property are reported but nothing is guaranteed: dwelling; single story, walls; brick and painted plaster under tiled roof; comprising of lounge, diningroom, 3 bedrooms, 1 bathroom, 1 kitchen, 1 W.C. floors; tiled and carpeted. Outbuildings: One garage. Improvements: None.

3. Terms—the purchase price shall be paid as to 10% thereof at the time of the sale, unless otherwise agreed by the Execution Creditor and the Messenger of the Court, and the unpaid balance together with interest on the full amount of the Judgment Creditor's claim at the rate of 15% per annum to date of payment, within 21 days to be paid or secured by an approved bank or building society guarantee.

4. The full conditions of sale may be inspected at the office of the Messenger of Court of Johannesburg and will be read out by the Messenger of Court immediately prior to the sale.

Melman, McCarthy & Serfontein, Plaintiff's Attorneys, Suite 4712, Carlton Centre, Commissioner Street, Johannesburg. Tel: 331 9526. Ref: D McCarthy/js.

Case 2061/87

IN THE MAGISTRATE'S COURT FOR THE DISTRICT OF JOHANNESBURG HELD AT JOHANNESBURG

In the matter between **Natal Building Society**, Plaintiff, and **Jerry Pyp Tshabalala**, Defendant

In pursuance of a Judgment in the Court of the Magistrate, Johannesburg District Johannesburg, and Writ of Execution dated the 10th February 1987 the following will be sold in execution on the 6th day of November 1987 at 10h00, Fox Street entrance of the Magistrate's Court Building, Johannesburg to the highest bidder:

The right of leasehold in erf: 456 Diepkloof extension.

In extent: 429 square metres, known as: 456 Diepkloof Extension Phase 2, Johannesburg.

Conditions of Sale:

1. The property shall be sold without reserve and to the highest bidder, and shall be subject to the terms and conditions of the Magistrate's Court Act and the Rules made thereunder, and of the title deeds in so far as these are applicable.

2. The following improvements on the property are reported but nothing is guaranteed: dwelling; single story, detached, walls; brick and painted plaster under tiled roof; comprising of lounge, diningroom, 2 bedrooms, 1 family room, 1 bathroom, 1 kitchen, 1 w.c. floors; fully carpeted tiles and vinyl. Outbuildings: double garage. Improvements: Patio, tiled stoep, slasto paving, brick wall and gate.

3. Terms—the purchase price shall be paid as to 10% thereof at the time of the sale, unless otherwise agreed by the Execution Creditor and the Messenger of the Court, and the unpaid balance together with interest on the full amount of the Judgment Creditor's claim at the rate of 15% per annum to date of payment, within 21 days to be paid or secured by an approved bank or building society guarantee.

4. The full conditions of sale may be inspected at the office of the Messenger of Court of Johannesburg and will be read out by the Messenger of Court immediately prior to the sale.

Melman, McCarthy & Serfontein, Plaintiff's Attorneys, Suite 4712, Carlton Centre, Commissioner Street, Johannesburg. Tel: 331 9526. Ref: D McCarthy/js.

IN DIE LANDDROSHOF VIR DIE DISTRIK VAN BRITS GEHOU TE BRITS

In die saak tussen **Allied Bouvereniging**, Eiser, en **J. C. F. Oosthuizen**, en mevrou **J. H. Oosthuizen**, Verweerders

Ingevolge 'n uitspraak van bogenoemde Hof en Lasbrief tot Eksekusie gedateer 20 Augustus 1987 sal die hierondervermelde eiendom geregtelik verkoop word op Vrydag 30 Oktober 1987, om 10h30 by die Landdroskantoor, Van Veldenstraat, Brits, aan die persoon wie die hoogste aanbod maak, naamlik:

Gedeelte 456 ('n gedeelte van Gedeelte 273) van die plaas Roodekopjes of Zwartkopjes 427 Registrasie Afdeling J.Q., Transvaal;

Groot 857 vierkante meter;

Gehou deur die Verweerder kragtens Akte van Transport T2595/87;

Die eiendom is verbeter met 'n woonhuis en nodige buitegeboue.

Die Verkoopsvoorwaardes wat onmiddellik voor die verkoping gelees sal word, lê ter insae te die kantore van die Adjunk-Balju, Murraylaan 43E, Brits. Die gesegde verkoopsvoorwaardes bevat onder andere die volgende voorwaardes:

a) Die koper moet 'n deposito van tien persent van die koopprys kontant op die dag van die verkoping betaal, die balans betaalbaar teen transport en verseker te word deur 'n waarborg van 'n Bank- of Bouvereniging wat deur die Eiser se Prokureur goedgekeur is, die waarborg aan die Adjunk-Balju binne 14 dae na die datum van die verkoping verstrek te word;

b) Die koper moet afslaersgelde op die dag van die Verkoping betaal.

Geteken te Brits op hierdie 9de dag van September 1987.

G. J. Pretorius vir Smuts, Pretorius, Krige & Roets, Prokureur vir Eiser, Van Veldenstraat 37, Posbus 32, Brits, 0250. Tel: 01211-24338/9.

IN DIE LANDDROSHOF VIR DIE DISTRIK VAN WONDERBOOM GEHOU TE PRETORIA-NOORD

In die saak tussen **Barlow Rand Limited**, Eiser, en **P. H. Veldtsman**, Verweerder

Kennis word hiermee gegee dat ingevolge 'n uitspraak van bogenoemde Hof op 19 Februarie 1986 en 'n Lasbrief vir Eksekusie van goed gedateer 3 September 1986, sal die hierna gemelde eiendom op die 6de dag van November 1987 om 10h00 te Landdroskantoor, Ben Viljoenstraat, Pretoria-Noord, geereglik verkoop word aan die bieder wat die hoogste bode maak onderhewig aan die voorwaardes hieronder aangegee.

Eiendom: Lopie Fouriestraat 377, Wolmer, Pretoria-Noord, Erf 328, dorpsgebied Wolmer J.R.

Groot: 1 313 vk. meter.

Gehou deur die Eksekusieskuldenaar kragtens Akte van Transport No. T64761/1980.

Eiendom is verbeter met woonhuis en buitegeboue.

Voorwaardes: Voorwaardes van verkoop ter insae by Geregsbode, 558 Gerrit Maritzstraat, Pretoria-Noord.

Geteken te Pretoria-Noord hierdie 15de dag van September 1987.

(Get) H. J. Nel vir A. J. van Deventer, Grondvloer Jancorgebou, Burgerstraat 295, Pretoria-Noord. Verw: K1/526 B rb.

IN THE MAGISTRATE'S COURT FOR THE DISTRICT OF BRAKPAN HELD AT BRAKPAN

In the matter between **Allied Building Society**, Plaintiff, and **B. S. van der Merwe**, 1st Defendant and **P. van der Merwe**, 2nd Defendant

In pursuance of a Judgment in the Court of the Magistrate of Brakpan and Writ of Execution dated the 11th day of August 1987, the property listed hereunder will be sold in Execution on the 6th day of November 1987, at 11 a.m. at the premises of the Messenger of the Court, 439 Prince George Avenue, Brakpan to the highest bidder:

Certain: Erf 926 Leachville Extension 1 Township Registration Division I R Transvaal.

Measuring 660 (six hundred and sixty) square metres.

Held by deed of transfer No: T30965/1986.

The Property is defined as a residential stand, situated at 67 Augrabies Avenue, Grenelefe, Brakpan.

No warrant or undertaking is given in relation to the nature of the improvements, which are described as follows:

Main Building: Lounge, diningroom, 2 bedrooms, bathroom plus separate toilet, kitchen, brick/plaster walls, tiled roof.

Outbuildings: Single garage, brick and plaster (75%) fencing.

The material conditions of sale are:

a) The sale will be held by Public Auction and without reserve and will be 'voetstoots'.

b) Immediately after the sale the Purchaser shall sign the Conditions of Sale which can be inspected at the Messenger of the Court's Office, Brakpan.

c) The purchaser shall pay all amounts necessary to obtain transfer of the property, including all costs of transfer, transfer duty, rates, taxes, licenses, sanitary fees, interest etc.

d) The purchase price shall be paid as to 10% (Ten per cent) thereof or R500,00 (Five hundred rand) whichever is the greater, on the day of the sale and the unpaid balance, together with interest on the full amount of the Judgment Creditor's claim at the rate specified in the full conditions of sale to date of payment, within fourteen days to be paid or secured by a Bank or Building Society guarantee.

e) The property shall be sold subject to any existing tenancy.

f) Failing compliance with the provisions of the conditions of Sale, the Purchaser shall forfeit for the benefit of the Execution Creditor the deposit referred to in (d) above, without prejudice to any claim against him for damages.

The full Conditions of Sale may be inspected at the Offices of the Messenger of the Court.

Dated at Brakpan on this 17th day of September 1987.

(Sgd) P. J. Cowling for Trollip, Joubert, Cowling & Janeke, 125A Kingsway Avenue, P.O. Box 38, Brakpan. Tel: 55-8363.

IN THE MAGISTRATE'S COURT FOR THE DISTRICT OF BRAKPAN HELD AT BRAKPAN

In the matter between **Allied Building Society**, Plaintiff, and **E. M. Plenaar**, Defendant

In pursuance of a Judgment in the Court of the Magistrate of Brakpan and Writ of Execution dated the 21st day of July 1987, the property listed hereunder will be sold in Execution on the 6th day of November 1987, at 11 a.m. at the premises of the Messenger of the Court, 439 Prince George Avenue, Brakpan to the highest bidder:

Certain: Erf 122 Brakpan-Noord, Township Registration Division I R Transvaal;

Measuring 1 012 (one thousand and twelve) square metres.

Held by Deed of Transfer No: T5825/1984.

The property is defined as a residential stand, situated at 4 Nomis Avenue, Brakpan North, Brakpan.

No warrant or undertaking is given in relation to the nature of the improvements, which are described as follows:

Main Building: Brick/plaster walls under tiled roof, lounge, diningroom, two bedrooms, bathroom, kitchen.

Outbuildings: Single garage, one toilet, pre-cast walling.

The material conditions of sale are:

- a) The sale will be held by Public Auction and without reserve and will be "voetstoots".
- b) Immediately after the sale the Purchaser shall sign the Conditions of Sale which can be inspected at the Messenger of the Court's Office, Brakpan.
- c) The purchaser shall pay all amounts necessary to obtain transfer of the property, including all costs of transfer, transfer duty, rates, taxes, licenses, sanitary fees, interest etc.
- d) The purchase price shall be paid as to 10% (Ten per cent) thereof or R500,00 (Five hundred rand) whichever is the greater, on the day of the sale and the unpaid balance, together with interest on the full amount of the Judgment Creditor's claim at the rate specified in the full conditions of sale to date of payment, within fourteen days to be paid or secured by a Bank or Building Society guarantee.
- e) The property shall be sold subject to any existing tenancy.
- f) Failing compliance with the provisions of the conditions of Sale, the Purchaser shall forfeit for the benefit of the Execution Creditor the deposit referred to in (d) above, without prejudice to any claim against him for damages.

The full Conditions of Sale may be inspected at the Offices of the Messenger of the Court.

Dated at Brakpan on this 17th day of September, 1987.

(Sgd) P. J. Cowling for Trollip, Joubert, Cowling & Janeke, 125A Kingsway Avenue, P.O. Box 38, Brakpan. Tel: 55-8363.

Case 1891/87

IN THE MAGISTRATE'S COURT FOR THE DISTRICT OF BRAKPAN HELD AT BRAKPAN

In the matter between **Allied Building Society**, Plaintiff, and **R. A. Gebhardt**, Defendant

In pursuance of a Judgment in the Court of the Magistrate of Brakpan and Writ of Execution dated the 23rd day of April 1987, the property listed hereunder will be sold in Execution on the 6th day of November 1987, at 11 a.m. at the premises of the Messenger of the Court, 439 Prince George Avenue, Brakpan to the highest bidder:

Certain: Erf 1002 Brakpan-Noord Extension 3 Registration Division I R Transvaal.

Measuring: 804 (eight hundred and four) square metres.

Held by Deed of Transfer No: T26980/1984.

The property is defined as a residential stand, situated at 13 Victor Street, Brakpan North Ext. 3, Brakpan.

No warrant or undertaking is given in relation to the nature of the improvements, which are described as follows:

Main Building: Brick/plaster walls, tiled roof, one lounge, one diningroom, three bedrooms, one bathroom, one kitchen.

Outbuildings: Single garage, one toilet, 75% diamond mesh fencing, paved drive-way.

The material conditions of sale are:

- a) The sale will be held by Public Auction and without reserve and will be "voetstoots".
- b) Immediately after the sale the Purchaser shall sign the Conditions of Sale which can be inspected at the Messenger of the Court's Office, Brakpan.
- c) The purchaser shall pay all amounts necessary to obtain transfer of the property, including all costs of transfer, transfer duty, rates, taxes, licenses, sanitary fees, interest etc.
- d) The purchase price shall be paid as to 10% (Ten per cent) thereof or R500,00 (Five hundred rand) whichever is the greater, on the day of the sale and the unpaid balance, together with interest on the full amount of the Judgment Creditor's claim at the rate specified in the full conditions of sale to date of payment, within fourteen days to be paid or secured by a Bank or Building Society guarantee.
- e) The property shall be sold subject to any existing tenancy.
- f) Failing compliance with the provisions of the conditions of Sale, the Purchaser shall forfeit for the benefit of the Execution Creditor the deposit referred to in (d) above, without prejudice to any claim against him for damages.

The full Conditions of Sale may be inspected at the Offices of the Messenger of the Court.

Dated at Brakpan on this 17th day of September 1987.

(Sgd) P. J. Cowling for Trollip, Joubert, Cowling & Janeke, 125A Kingsway Avenue, P.O. Box 38, Brakpan. Tel: 55-8363.

Case 6715/87

IN THE MAGISTRATE'S COURT FOR THE DISTRICT OF VEREENIGING HELD AT VEREENIGING

In the matter between **United Building Society**, Plaintiff (Execution Creditor), and **Rajko John Sarkic**, Defendant (Execution Debtor)

In execution of the judgment granted herein and subsequent notice of attachment dated the 21st day of September 1987 the undermentioned property will be sold by the Messenger of the Court on the 29th day of October 1987 at the offices of the Messenger of the Court, Sherman Building 7 Loch Street, Meyerton, at 10.00 a.m.

Description: Certain improved residential property situate in Meyerton Farms Township, Registration Division I.R., Transvaal;

Being Portion 27 of Erf 183 in extent 1 000 (one thousand) square metres; (2 bedrooms house with lounge, dining room, kitchen, bathroom and toilet, separate toilet, attached carport, fencing).

The outstanding amount under the existing bond amounts to plus minus R41 289,00.

The street address of the property is 88 Zebra Street, Meyerton Small Farms, Meyerton.

Conditions:

1. The sale shall be subject to the provisions laid down by the Magistrate's Court Act No. 32 of 1944, and the Rules made thereunder, the conditions contained in the Title Deed/s and will be sold to the highest bidder without reserve.

2. The purchaser shall pay to the Messenger of the Court 10% of the purchase price immediately upon signature of the Conditions of Sale and furnish him with a Bank or Building Society guarantee within (14) fourteen days from the date of the sale for the balance of the purchase price.

3. The Execution Creditor will consider favourably granting an approved purchaser a loan up to 90% of the purchase price of the property and arrangements should be made with the Execution Creditor before the sale.

4. The full conditions of the sale may be inspected at the office of the Messenger of the Court during office hours and will be read out before the property is put up for sale.

Dated at Vereeniging this 28th day of September 1987.

(Sgd) E. H. Lyell for Steyn Lyell & Marais, Attorneys for Execution Creditor, Second Floor, United Building, Voortrekker Street, P.O. Box 83, Vereeniging. Tel. 21-4471.

Saak 10662/87

IN DIE HOOGGEREGSHOF VAN SUID-AFRIKA

(Transvaalse Provinsiale Afdeling)

In die saak tussen **Volkskas Beperk**, Eiser, en **Stephanus Johannes Leppan**, Verweerder

Ten uitvoerlegging van 'n Vonnis in die bogemelde Agbare Hof, gedateer die 28ste dag van Julie 1987 en 'n Lasbrief vir Eksekusie word die volgende eiendom in eksekusie verkoop op die 4de dag van November 1987 om 10h00 by die kantoor van die Adjunk-Balju, Strubenstraat 142, Pretoria aan die hoogste bieder, sonder reserwe:

Deel 6 soos getoon en volledig beskryf op Deelplan SS. 81/77, in die gebou of geboue bekend as Faroma Court van welke deel die vloeroppervlakte volgens voormelde Deelplan 99 vierkante meter groot is; en 'n onverdeelde aandeel in die gemeenskaplike eiendom in die grond en geboue soos getoon en volledig beskryf op genoemde deelplan, toegeheel aan genoemde deel in ooreenstemming met die deelnemingskwota van genoemde deel, gespesifiseer in 'n bylae op genoemde deelplan aangeteken.

Gehou kragtens sertifikaat van geregistreerde deeltitel ST.81/1977 (6) (Unit). (Ook bekend as Deel 6, Faroma Court, Masseylaan 1243, Queenswood, Pretoria).

Die eiendom is 'n duplexwoonstel bestaande uit drie slaapkamers, eet- en sitkamer gekombineerd, aparte toilet, badkamer en kombuis, motorafdak. Die kompleks bestaan uit 13 wooneenhede.

Terme en Voorwaardes:

Terme: Die koopprys sal wees 10% (Tien persent) daarvan by verkoping en die balans moet binne 10 dae verseker word by wyse van 'n Bank- of Bouvereniging waarborg.

Voorwaardes: Die volle voorwaardes van verkoping wat deur die Adjunk-Balju van Pretoria onmiddellik voor die verkoping uitgelees sal word, ter insae lê by die kantoor van die Adjunk-Balju, Strubenstraat 142, Pretoria.

Geteken te Pretoria op hierdie 11de dag van September 1987.

Tim du Toit & Kie Ingelyf, Prokureurs vir Eiser, Volkskasgebou 1920, Strijdomplein, Pretoria. Mnr De Villiers/hs. Tel: 325-2277/88.

Saak 87/2548

IN DIE LANDDROSHOF VIR DIE DISTRIK VAN SPRINGS GEHOU TE SPRINGS

In die saak tussen **Allied Bouvereniging**, Eiser, en **Jozef Uri**, Verweerder

Ingevolge 'n uitspraak van bogenoemde Agbare Hof en geregtelike Lasbrief, sal die ondervermelde eiendom op Vrydag die 6de dag van November 1987 om 15h00 deur die Geregsbode, Springs aan die hoogste bieder verkoop word:

Sekere Erwe 874 en 876 geleë in die Dorpsgebied Springs, Registrasie Afdeling I.R., Transvaal synde No. 140—7de Straat, Springs en bestaande uit 'n baksteen huis onder sinkdak met ingangsportaal, sitkamer, eetkamer, drie slaapkamers, kombuis, spens, twee badkamers, twee motorhuise en gewone buitegeboue.

Voorwaardes: Die verkoping sal onderworpe wees aan die betaling van tien persent van die koopprys op die dag van die verkoping en 'n Bank- of Bougenootskapswaarborg moet binne veertien dae daarna gelewer word vir die betaling van die balans. Die volledige koopvoorwaardes, wat onmiddellik voor die veiling voorgelees sal word, sal by die kantoor van die Geregsbode, Springs ter insae lê.

Gedateer te Springs op hede die 16de Oktober 1987.

Ivan Davies Theunissen, Eiser se Prokureur, IDT Gebou, Vierde Straat 64, Posbus 16, Springs. 812-1050. (Verwys mnr. B. Cooper/AvdB.)

Case 14307/1986

IN THE SUPREME COURT OF SOUTH AFRICA

(Witwatersrand Local Division)

In the matter between **Nedbank Limited**, Plaintiff, and **Phillippus Albertus Strydom**, Defendant

In pursuance of a Judgment in the Supreme Court of South Africa (Witwatersrand Local Division) and Writ of Execution dated 16th September, 1986, the property listed herein will be sold in execution on Thursday the 29th day of October, 1987 at 11h00 at the office of the Deputy Sheriff, 1st Floor, Rothburn House, 61 Woburn Avenue, Cor. Rothsay Street, Benoni, to the highest bidder with a reserve price of R47 437,12 plus 14.5% interest from 28th July, 1987 to date of cancellation of bond:

Erf 1213 Crystal Park Ext. 1 Township, Registration Division I.R. Transvaal.

Situate on 11 Hlobane Crescent, Crystal Park, Benoni.

Measuring 813 square metres.

The improvements on the property are described as set out hereunder but no warranties are given in respect thereof:

Improvements: Brick under tile dwelling consisting of lounge, diningroom, 2 bedrooms, bathroom and w/c, kitchen; Outbuilding: garage, servant's w/c.

Terms: The purchase price shall be paid as to ten per cent (10%) thereof on the day of the sale and the unpaid balance against transfer to be secured by a bank or building society guarantee, to be approved by Plaintiff's attorney, to be furnished to the Deputy Sheriff within thirty (30) days after the date of sale.

If transfer of the property is not registered within one month after the sale, the purchaser shall be liable for payment of interest to the Plaintiff at the rate of 19.5% per annum and to the bondholder at the rate applicable to the bond on the respective amounts of the award to the Plaintiff and the bondholder in the plan of distribution as from the expiration of one month after the sale to date of transfer.

The conditions of sale, which will be read immediately prior to the sale, may be inspected at the office of the Deputy Sheriff, at the address set out above.

Barry Katz & Partners, 8th Floor, Trust Bank Centre, Voortrekker Street, P.O. Box 367, Kempton Park, 1620. Ref. Mr Katz/mr. Tel. 970-1000/6.

Case 16629/87

IN THE SUPREME COURT OF SOUTH AFRICA

(Witwatersrand Local Division)

In the matter between **South African Permanent Building Society**, Plaintiff, and **Bell Curle**, Defendant

In execution of a Judgment of the Supreme Court of South Africa (Witwatersrand Local Division) in this suit, a sale without reserve will be held at the office of the deputy sheriff, No. 6 Elna Randhof Corner, Corner Blairgowrie Drive and Selkirk Avenue, Blairgowrie, Randburg at 10h00 on 3 November 1987 in the forenoon of the undermentioned property of the Defendant on Conditions to be read out by the Auctioneer at the time of the sale and which may be inspected at the office of the Deputy Sheriff prior to the sale.

Certain: Portion 1 of Erf 398 Johannesburg North Township, Registration Division I.Q., Transvaal;

Situation: Portion 1 of 398 Conduit Road, Johannesburg North;

Area: 1 100 (one thousand one hundred) square metres;

Improvements (not guaranteed): A double storey house under thatch roof, consisting of four rooms, two bathrooms, swimming pool and brick wall surrounding property.

Terms: 10% of the purchase price in cash on the day of the sale; the balance and interest on the full purchase price at current bond rates payable against registration of transfer, to be secured by a bank, building society or other acceptable guarantee to be furnished within 14 (fourteen) days from the date of sale. Auctioneer's charges are payable on the day of the sale and calculated at 5% on the proceeds of the sale up to a price of R10 000,00 and thereafter 2½%, to a maximum fee of R5 000,00 and a minimum of R30,00.

Dated at Johannesburg on this the 18th day of September 1987.

Sgd. A. Lowndes for Smit & Lowndes, Plaintiff's Attorneys, 10th Floor, S A Centre, 253 Bree Street, P.O. Box 8274, Johannesburg. Tel: 337 6015. Ref: Mr Lowndes/SAP103.AGL.

T11470/87

IN DIE HOOGGEREGSHOF VAN SUID-AFRIKA

(Transvaalse Provinsiale Afdeling)

In die saak tussen **Saambou Nasionale Bouvereniging**, Eiser, en **Petronella Magrieta Mlekella**, Verweerderes

Kennis word hiermee gegee dat ingevolge 'n uitspraak van bogemelde Agbare Hof in bogemelde saak op 4 Augustus 1987 en ter uitvoering van 'n Lasbrief vir beslaglegging uitgereik op 7 Augustus 1987 sal die Adjunk-Balju, Pretoria op die 4de dag van November 1987, om 10h00, te sy kantoor Strubenstraat 142, Pretoria per openbare veiling die ondervermelde eiendom verkoop:

Deel No. 5 soos getoon en vollediger beskryf op Deelplan No. SS 104/84 in die gebou of geboue bekend as Poku, Muckleneuk.

Groot: 32 (twee en dertig) vierkante meter.

Gehou kragtens sertifikaat van Geregistreerde Deeltitel No. ST 104/84 (5) gedateer 22 Mei 1984.

Unit

(Ook bekend as Poku w/s No. 15, Walkerstraat 491, Muckleneuk, Pretoria.)

Verbeterings: 1 Kamer, kombuis, badkamer en toilet.

Terme: Die koper moet 'n deposit van tien persent van die koopprys in kontant op die dag van die verkoping betaal. Die balans moet verseker word deur 'n bank- of bougenootskapswaarborg wat deur Eiser se prokureurs goedgekeur is en verstrekk te word aan gesegde prokureurs binne veertien dae na datum van verkoping, en soos meer volledig blyk uit die Voorwaardes van Verkoping wat nagegaan kan word ten kantore van die Adjunk-Balju, Pretoria gedurende kantoorure.

Voorwaardes: Die eiendom sal verkoop word aan die hoogste bieder sonder enige reserweprys.

Gedateer te Pretoria op hierdie 6de dag van Oktober 1987.

(Get) L. M. Erasmus vir Ross & Jacobsz, R & J Gebou, Kerkstraat-Oos 421, Arcadia. Verw: L. M. Erasmus. Tel: 28-3709. Verw: LE/1908.

Case 6117/87

IN THE SUPREME COURT OF SOUTH AFRICA

(Witwatersrand Local Division)

In the matter between **South African Permanent Building Society**, Plaintiff, and **Matu Mary Sebeela**, Defendant

In execution of a judgment of the Supreme Court of South Africa (Witwatersrand Local Division) in this suit, a sale without reserve will be held at the office of the Deputy Sheriff, 131 Marshall Street, Johannesburg at 10 o'clock on 5th November 1987 in the forenoon, of the undermentioned property of the Defendant on Conditions to be read out by the Auctioneer at the time of the sale and which may be inspected at the office of the Deputy Sheriff prior to the sale.

Certain: Right of leasehold in respect of Lot 1022 Tladi Township.

Area: 374 square metres.

Situation: 1022 Tladi.

Improvements (not guaranteed): "A house under asbestos roof consisting of 2 bedrooms, lounge, lino flooring, single garage, 2 rooms in outbuilding with wire fencing around property".

Terms: 10% of the purchase price in cash on the day of the sale; the balance and interest on the full purchase price at current bond rates payable against registration of transfer, to be secured by a bank, building society or other acceptable guarantee to be furnished within 14 days from the date of sale. Auctioneer's charges are payable on the day of the sale and calculated at 5% on the proceeds of the sale up to a price of R10 000,00 and thereafter 2½%, to a maximum fee of R5 000,00 and a minimum of R30,00.

Dated at Johannesburg on 5th October 1987.

Sgd. S. E. van Zyl for E. F. K. Tucker Inc., Plaintiff's Attorneys, 48th Floor, Carlton Centre, Commissioner Street, Johannesburg. Tel: 331-7211. Ref: Foreclosures/SAPE 7109-976.

Case 15541/86

IN THE SUPREME COURT OF SOUTH AFRICA
(Witwatersrand Local Division)

In the matter between **Small Business Development Corporation Limited**, Plaintiff, and **Bennett Mlangeni**, Defendant

In execution of a judgment of the Supreme Court of South Africa (Witwatersrand Local Division) in the above-mentioned suit, a sale without reserve will be held at the office of the Deputy Sheriff, at 131 Marshall Street, Johannesburg, on the 5th day of November 1987 at 10h00 of the undermentioned property of the defendant on the conditions to be read out by the Auctioneer at the offices of the Deputy Sheriff, 131 Marshall Street, Johannesburg, prior to the sale.

Site numbers 2056, and 2057 and 2058, Tladi, as shown on Plan L, No. 251/80 including the improvements thereon, situated in Matlomo Street, next to the Tladi Training Centre, Corner of Digwale Street.

The following information is furnished, *re* the improvements, though in this respect nothing is guaranteed: The improvements consist of *inter alia*, a building in which is conducted a business of a Restaurant and a Night Club.

Terms: 10% (ten per cent) of the purchase price in cash on the day of the sale, the balance payable against registration of transfer, to be secured by a Bank or Building Society—or other acceptable guarantee to be furnished within 14 (fourteen) days from the date of sale.

Auctioneer charges payable on the day of sale, to be calculated as follows: 5% (Five Per Cent) on the proceeds of the sale up to a price of R10 000,00 (ten thousand rand) and thereafter 2½ (two and a half per cent) up to a maximum fee of R5 000,00 (five thousand rand). Minimum charges: R30,00 (thirty rand).

Dated at Johannesburg this the 29th day of September 1987.

(Sgd) John G. Hunter for John G. Hunter, Attorney for Plaintiff, 301 Palace Buildings, 52 Pritchard Street, P.O. Box 4693, Johannesburg. Tel: 832-1401/3. Ref: Mr Hunter/pt.

Case 87/16248

IN THE SUPREME COURT OF SOUTH AFRICA
(Witwatersrand Local Division)

In the matter between **United Building Society**, Plaintiff, and **Tutuzi James Khumalo (male)**, Defendant

In execution of a Judgment of the Supreme Court of South Africa (Witwatersrand Local Division) in the above-mentioned suit a Sale without Reserve will be held at the office of the Deputy Sheriff, at 131 Marshall Street, Johannesburg on the 5th day of November 1987 at 10h00 of the undermentioned property of the Defendant on the Conditions to be read out by the Auctioneer at the offices of the Deputy Sheriff, 133 Marshall Street, Johannesburg prior to the sale. All right, title and interest in the leasehold of Lot Number 1747 in the township of Protea North. Held by Tutuzi James Khumalo under Certificate of Registered Grant of Leasehold No. TL 30884/1986. Measuring 262 Square metres.

The physical address is Stand 1747 Protea North. Group Area Black.

The following information is furnished *re* the improvements, though in this respect nothing is guaranteed:

Residence comprising of—Lounge, dining room, 3 bedrooms, bathroom, separate w c, kitchen.

Terms: 10% (ten per cent) of the purchase price in cash on the day of the sale, the balance payable against registration of Transfer, to be secured by a Bank—or Building Society—or other acceptable guarantee to be furnished within 14 (fourteen) days from the date of sale. Auctioneers charges, payable on the day of sale, to be calculated as follows: 5% (five per cent) on the proceeds of the sale up to a price of R10 000,00 (ten thousand rand) and thereafter 2½% (two and a half per cent) up to a maximum fee of R5 000,00 (five thousand rand). Minimum charges R30,00 (thirty rand).

Date: At Johannesburg on this the 5th day of October, 1987.

Bowens Garlicke and Bousfield, Plaintiff's Attorneys, 7th Floor, Hunts Corner, 20 New Street South Johannesburg. Tel 836-4179. P.O. Box 6434. Ref Mrs Botha.

Case 13129/86

IN THE SUPREME COURT OF SOUTH AFRICA
(Transvaal Provincial Division)

In the matter between **First National Bank of Southern Africa Limited**, Plaintiff, and **Adriaan Hendrikus Lamprecht**, Defendant

In terms of a judgment of the Supreme Court of South Africa (Transvaal Provincial Division) and writ dated 21 October 1986 in the above matter, a sale by public auction subject to confirmation will be held by the deputy sheriff, Balfour, in front of the Magistrate's Court, Frank Street, Balfour, Transvaal on Saturday 7 November 1987 at 09h00 upon conditions which may now be inspected at the offices of the deputy sheriff, Vlakfontein, Balfour of the following property:

Portion 1 of Erf 562 situate in the town Balfour, registration division I.R., Transvaal;

Measuring: 1 427 square metres;

Held by Adriaan Hendrikus Lamprecht (Identity number 5607265025004) under deed of transfer No. T 35108/1985.

The property has been improved by the erection of a dwelling thereon of brick under iron roof consisting of three bedrooms, combined lounge and dining room, a kitchen, toilet, car port. The property is fenced.

This property is known as 46A Montique, Balfour, Transvaal.

No guarantee is given as to the nature and extent of the property or as to the improvements on the property.

Terms:

Ten per centum (10%) of the purchase price and auctioneer's charges in cash on the day of the sale, the balance against transfer to be secured by a bank or building society or other acceptable guarantee to be furnished to the deputy sheriff within fourteen (14) days from the date of sale.

R. M. Brink, for Rooth & Wessels, Attorney for Plaintiff, First National Bank Building, Church Square, Pretoria. (Tel: (012) 3252940.)

Saak 8219/86

IN DIE LANDDROSHOF VIR DIE DISTRIK VAN WELKOM GEHOU TE WELKOM

In die saak tussen **Die Trust Bank van Afrika Beperk**, Eiser, en **M. Nortje**, Verweerder

Ten uitvoerlegging van 'n vonnis in die Landdroshof Alberton gedateer 15de dag van Augustus 1985, en lasbrief vir Eksekusie gedateer 15de dag van Augustus 1985, sal die volgende eiendom in eksekusie verkoop word, sonder reserwe, aan die hoogste aanbieder op Woensdag die 11de dag van November 1987 om 10h00 by die kantore van die Geregsbode te Johria Hof, Du Plessisweg 4, Florentia, Alberton, naamlik:

Sekere: Erf 917 New Redruth Dorpsgebied, Registrasie afdeling I R Transvaal;

Ook bekend as: Porthpeanstraat 7, New Redruth, Alberton;

Groot: 773 Vierkante Meter;

Gehou deur: Marius Nortje onder Akte van Transportnommer T 19961/85.

Sonering: Residensiëel.

Spesiale gebruiksvergunninge of vrystellings: Geen.

Groepsgebiedewet: Blank.

Die Vonnis Skuldeiser beskryf die verbeterings op die eiendom, sonder om dit te waarborg as volg:

Hoofgebou: Baksteengebou met sinkdak, bestaande uit 3 Slaapkamers, 1 Eetkamer, 1 Sitkamer, 1 Kombuis, 1½ Badkamers en 2 Toilette.

Buitegeboue: Slegs omheining.

Terme en Voorwaardes van Verkoop:

1. *Terme:*

Die Koopprijs is betaalbaar teen 10% ten tye van die verkoping en die onbetaalde balans plus rente teen 18% (Agtien Per Sentum) per jaar tot datum van betaling binne 30 (Dertig) dae of gewaarborg deur 'n goedgekeurde Bank en/of Bouvereniging Waarborg.

2. *Voorwaardes:*

Die volle voorwaardes van verkoping wat deur die Geregsbode onmiddellik voor die verkoping uitgelees sal word, lê ter insae by die Kantoor van die Geregsbode te Johria Hof, Du Plessisweg 4, Florentia, Alberton.

Gedateer te Alberton hierdie 22ste dag van September 1987.

Wessels & Smith, vir Klopper, Jonker & Vennote, Eiser se Prokureurs, 1ste Vloer, Terracegebou, Eaton Terrace, New Redruth, Alberton. SH 1155.

Saak 567/87

IN DIE LANDDROSHOF VIR DIE DISTRIK VAN KLERKSDORP GEHOU TE KLERKSDORP

In die saak tussen **Trek Petroleum (Edms.) Beperk**, Eiser, en **H. C. Esterhuizen**, Verweerder

Uit kragte van 'n Vonnis van die Landdroshof van Klerksdorp en kragtens 'n Lasbrief vir Eksekusie gedateer 18 Augustus 1987 sal ondervermelde eiendom op die 6de dag van November 1986 om 10h00 by die kantore van die Geregsbode, Leaskstraat 23, Klerksdorp aan die hoogste bieder geregtelike en sonder voorbehoud verkoop word vir kontant of 'n deposito van 10% kontant en die balans van die koopsom verseker te word deur 'n goedgekeurde Bank-of Bougenootskapswaarborg binne 30 (Dertig) dae na datum van koop:

Erf 625 geleë in die dorp La Hoff, Registrasie Afdeling I.P. Transvaal.

Groot 1 690 vierkante meter.

Gehou kragtens Akte van Transport No. 39004/1975.

Die volgende verbeterings word beweer op die eiendom te Von Willighstraat 88, La Hoff, Klerksdorp te wees: Enkelverdieping woonhuis bestaande uit: 6 (Ses) kamers, 1 (Een) kombuis; 1 (Een) ingangsportaal; 2 (Twee) badkamers, 1 (Een) stort; die huis is gebou met stene onder 'n dak van sinkplate; Buitegeboue bestaande uit: 2 motorhuise; 2 (Twee) afdakke vir motors; bediendekamer.

Die volledige voorwaardes van die verkoop kan by die Geregsbode voornoem geïnspekteer word of by die kantore van die Eiser se prokureurs.

Gedateer te Klerksdorp op hede hierdie 25ste dag van September 1987.

(Get) D. J. Lindemann, vir Erasmus Jooste, Eiser se Prokureurs, Joostegebou, Siddlestraat 49, Klerksdorp. Tel. 2-1581/5.

Saak 8999/87

IN DIE HOOGGEREGSHOF VAN SUID-AFRIKA

(Transvaalse Provinsiale Afdeling)

In die saak tussen **Volkskas Beperk**, Eiser, en **Simon Bos**, Verweerder

Ten uitvoerlegging van 'n Vonnis in die bogemelde Agbare Hof, gedateer die 14de dag van Julie 1987 en 'n Lasbrief vir Eksekusie word die volgende eiendom in eksekusie verkoop op die 30ste dag van Oktober 1987 om 10h00 by die Landdroshofkantore, Paul Krugerstraat, Bronkhorstspuit aan die hoogste bieder sonder reserwe:

Erf 381 geleë in die dorp Riamarpark, Registrasie Afdeling J.R., Transvaal.

Groot 1 120 vierkante meter.

Gehou kragtens Akte van Transport T.23844/84.

Die eiendom bestaan uit 'n drie slaapkamer huis met moderne kombuis, sit/eetkamer, badkamer met stort, wasbak en toilet, aparte toilet en buitegeboue bestaande uit waskamer en motorhuis vir een motor.

Terme en Voorwaardes

Terme

Die koopprijs sal wees 10% (Tien Persent) daarvan by verkoping en die balans moet binne 10 dae verseker word by wyse van 'n Bank- of Bouverenigingwaarborg.

Voorwaardes

Die volle voorwaardes van verkoping wat deur die Adjunk-Balju van Bronkhorstspuit onmiddellik voor die verkoping uitgelees sal word, ter insae lê by die kantoor van die Adjunk-Balju, Stadsentrum, 5de Vloer, Pretoriusstraat 272, Pretoria.

Geteken te Pretoria op hierdie 26ste dag van Augustus 1987.

J. H. de Villiers, vir Tim du Toit & Kie Ingelyf, Prokureurs vir Eiser, Volkskasgebou 1920, Strijdomplein, Pretoria. (Mnr. De Villiers/bs, Tel: 325-2277/88.)

IN THE SUPREME COURT OF SOUTH AFRICA
(Transvaal Provincial Division)

In the matter between **South African Permanent Building Society**, Plaintiff, and **Dawid Johannes Gouws**, Defendant

Pursuant to a Judgment of the above Court and Writ of Execution dated the 6th November 1986, the undermentioned property will be sold in execution at 9.30 a.m. on Friday the 30 October 1987, at the offices of the Deputy Sheriff 43E Murray Avenue, Brits, to the highest bidder:

Erf 138, situate in the Township Elandsrand, Registration Division J Q Transvaal;

Measuring 1 261 square metres;

Held by the Defendant under Deed of Transfer No. T28095/78;

Known as 29 Drakensberg Crescent, Elandsrand Brits;

The following improvements are situate on the property, although in this respect nothing is guaranteed.

A dwelling house consisting of the three bedrooms, lounge, dining room, two bathrooms and toilet.

Outbuildings consist of garage and toilet.

The conditions of Sale, which will be read immediately prior to the sale, are lying for inspection at the offices of the Deputy Sheriff 43E Murray Avenue, Brits.

Signed at Pretoria, this 11th day of September 1987.

(Sgd) M. S. L. Coetzee, c/o Findlay & Niemeyer, Plaintiff's Attorney, 635 Permanent Building, Paul Kruger Street, Pretoria. Tel: 26-2487. Ref: Mrs Rowe.

Case 7999/1985

IN THE SUPREME COURT OF SOUTH AFRICA
(Transvaal Provincial Division)

In the matter between **South Africa Permanent Building Society**, Plaintiff, and **Martha Petrocina Maria Catharina Pienaar**, Defendant

Pursuant to a judgment of the above Court and Writ of Execution dated the 6th day of August, 1985, the undermentioned property will be sold in execution on Wednesday, 4th November, 1987 at 11h00 in front of the Magistrate's Court, Cullinan, to the highest bidder:

Portion 180 (a Portion of Portion 8) of the farm Mooiplaas No. 367, Registration Division J.R., Transvaal:

Measuring 8,5653 hectares:

Held by the Defendant under Deed of Transfer No. 29469/1982.

The following improvements are situate on the property, although in this respect nothing is guaranteed:

A dwelling house consisting of lounge, dining room, three bedrooms, kitchen and bathroom, with fitted carpets. Outbuildings consist of three garages and a store room. There is a borehole on the property.

The Conditions of Sale, which will be read immediately prior to the sale, are lying for inspection at the offices of the Deputy Sheriff for the District of Cullinan, 230 Van Erkom Building, 217 Pretorius Street, Pretoria.

Signed at Pretoria, this 30th day of September, 1987.

(Sgd) M. S. L. Coetzee, c/o Findlay & Niemeyer, Plaintiff's Attorney, 635 Permanent Building, Paul Kruger Street, Pretoria. Tel. 26-2487. Ref. Mrs. Rowe.

Case 2839/87

IN THE SUPREME COURT OF SOUTH AFRICA
(Transvaal Provincial Division)

In the matter between **South African Permanent Building Society**, Plaintiff, and **Gert Benjamin Johannes Jacobs and Charmaine, Magdalena Jacobs and Karl Amatnieks**, Defendants

Pursuant to a Judgment of the above Court and Writ of Execution dated the 28th July 1987, the undermentioned property will be sold in execution at 10h00 on Wednesday the 4th November 1987 at the offices of the Deputy Sheriff, 142 Struben Street, Pretoria to the highest bidder:

Erf 2, situate in the township Pretorius Park, Registration Division J R Transvaal;

Measuring 1 000 square metres;

Held by the Defendant under Deed of Transfer No. 39451/85 known as 877 Patryshond Street, Pretorius Park, Pretoria.

The following improvements are situate on the property although in this respect nothing is guaranteed:

Two semi-detached houses each consisting of a lounge, Dining Room 2 bedrooms, 1 bathroom and 1 kitchen.

Outbuildings: Storeroom and toilet for each house.

The Conditions of sale, which will be read immediately prior to the sale, are lying for inspection at the offices of the Deputy Sheriff.

Signed at Pretoria, this the, 30th day of September 1987.

(Sgd) M. S. L. Coetzee, c/o Findlay & Niemeyer, Plaintiff's Attorney, 635 Permanent Building, Paul Kruger Street, Pretoria. Ref: Mrs Rowe.

Saak 212/87

IN DIE LANDDROSHOF VIR DIE DISTRIK VAN JOHANNESBURG GEHOU TE JOHANNESBURG

In die saak tussen **Barclays National Bank Limited**, Eiser, en **V. A. C. Craythorn**, Verweerder

Ingevolge 'n Vonnis van die Landdroshof te Roodepoort en 'n Lasbrief vir Eksekusie gedateer die 3de dag van Junie 1987 sal die volgende eiendom in eksekusie verkoop word te, voor die Landdroshof Kantoor, Randburg op die 4de dag van November 1987 om 10h00 aan die hoogste bieder, naamlik—

Erf 103 Windsor Dorpsgebied, Registrasie Afdeling I.Q. Transvaal.

Groot 895 (Agthonderd Vyf en Negentig) vierkante meter.

Gehou deur Vincent Alexander Christopher Craythorn kragtens Transportakte No. 57132/1983.

Ook bekend as No. 2 Queens Avenue, Windsor.

Geen waarborg of onderneming word gegee ten opsigte van die aard van of in verband met die verbeterings.

Titelakte Voorwaarde—Streng vir woning doeleindes alleenlik

Terme: Tien persent (10%) van die koopprys in kontant betaalbaar ten tye van die verkoping en die balans teen registrasie van transport, verseker te word deur 'n goedgekeurde bank- of bouvereniging waarborg binne 15 (vyftien) dae na datum van verkoping.

Die Verkoopsvoorwaardes mag gedurende kantoorure te Kantore van die Geregsbode, Randhof, Randburg ondersoek word.

Gedateer te Johannesburg op die 1ste Oktober 1987.

Alberts Van Biljon & Schickerling, Nathanson Bowman & Nathan, Eiser se Prokureurs, 5de Vloer, Burlington House, Rissikstraat 22, Johannesburg.

Saak 16210/86

IN DIE HOOGGEREGSHOF VAN SUID-AFRIKA

(Transvaalse Provinsiale Afdeling)

In die saak tussen **The Provident Fund for the Clothing Industry (Tvl)**, Eiser, en **Lendor Beleggings (Edms.) Bpk.**, 1ste Verweerder, **Daniel van der Merwe**, 2de Verweerder, **Marietta van der Merwe**, 3de Verweerder

Ten uitvoerlegging van 'n vonnis van bogemelde Hof en 'n Lasbrief tot Eksekusie, gedateer 23 Januarie 1987 sal die ondervermelde eiendom in eksekusie verkoop word op 30 Oktober 1987 om 09h00 te die kantore van die Adjunk-Balju, Murraylaan 43E, Brits, aan die hoogste bieder:

Sekere Gedeelte 199 ('n Gedeelte van Gedeelte 118) van die plaas Zandfontein 447, Registrasie Afdeling J Q, Transvaal:

Groot 20,0133 ha.

Gehou deur 1ste Verweerder kragtens Transportakte No. T 16355/85.

Die volgende verbeterings is aan die eiendom aangebring, alhoewel geen waarborg in dié verband gegee word nie:

Twee toegeruste boorgate;

Wild omheining, in goeie toestand.

Die verkoopsvoorwaardes, wat onmiddellik voor die verkoping gelees sal word, lê ter insae te die kantore van die Adjunk-Balju, Murraylaan 43E, Brits.

Geteken te Pretoria die 2de dag van September 1987.

Metelerkamp & Ritson, Prokureurs vir Eiser, IBM Gebou, Paul Krugerstraat, Pretoria. (GA/eb.)

Case 16210/86

IN THE SUPREME COURT OF SOUTH AFRICA

(Transvaal Provincial Division)

In the matter between **The Provident Fund for the Clothing Industry (Tvl)**, Plaintiff, and **Lendor Beleggings (Edms.) Bpk.**, 1st Defendant, **Daniel van der Merwe**, 2nd Defendant, **Marietta van der Merwe**, 3rd Defendant

Pursuant to a judgment of the above Court and Writ of Execution dated 23rd January 1987 the undermentioned property will be sold in execution on 30 October 1987 at 09h00 at the offices of the Deputy Sheriff, 43E Murray Avenue, Brits, to the highest bidder:

Certain Portion 199 (a Portion of Portion 118) of the farm Zandfontein 447, Registration Division J Q, Transvaal;

Measuring 20.0133 ha;

Held at 1st Defendant under Deed of Transfer No. T 16355/85.

The following improvements are situate on the property, although in this respect nothing is guaranteed:

Two equipped boreholes;

Game fencing, in good condition.

The conditions of sale, which will be read immediately prior to the sale, are lying for inspection at the offices of the Deputy Sheriff, 43E Murray Avenue, Brits.

Dated at Pretoria this 2nd day of September 1987.

Metelerkamp & Ritson, Attorneys for Plaintiff, IBM Building, Paul Kruger Street, Pretoria. (GA/eb.)

Saak 4027/87

IN DIE HOOGGEREGSHOF VAN SUID-AFRIKA

(Witwatersrandse Plaaslike Afdeling)

In die saak tussen **Allied Bouvereniging**, Eiser, en **Adeline May Wooldridge**, Verweerder

Ter uitwinning van 'n vonnis van die Hoogeregshof van Suid-Afrika (Witwatersrandse Plaaslike Afdeling) in bogemelde saak, sal 'n verkoping sonder 'n reserweprys, die prys onderhewig aan die goedkeuring van die Eiser, gehou word te die kantore van die Adjunk-Balju, Marshallstraat 131, Johannesburg op die 5de dag van November 1987, om 10h00 van die ondervermelde eiendom van die Verweerder op die voorwaardes wat deur die vendisieafslaer gelees word ten tyde van die verkoping en welke voorwaardes hy die kantore van die Adjunk-Balju voor die verkoping ter insae sal lê.

(Beskryf eiendom asook straatnommer.)

Sekere: Erf 1287, Parkhurst Dorpsgebied, Registrasie Afdeling I.R. Transvaal en ook bekend as 11de Straat 41, Parkhurst, Johannesburg.

Grootte: 495 vierkante meter.

Verbeterings (geen waarborg in verband hiermee word gegee nie) *bestaan uit die volgende*:

Hoofgebou: Ingangsportaal, sitkamer, eetkamer, studeerkamer, familiekamer, 3 slaapkamers, kombuis, badkamer/toilet, stort, toilet.

Konstruktueer: Baksteen onder sinkdak.

Buitegeboue: 2 Motorhuise, 1 bediendekamer, toilet, opwasplek, muuromheining, gekonstruktueer: baksteen onder sinkdak.

Terme: 10% (Tien persent) van die koopprys in kontant op die dag van verkoping en ten opsigte van die balans betaalbaar teen registrasie van transport, moet 'n Bank- of Bougenootskap- of ander aanneembare waarborg binne 14 (Veertien) dae vanaf datum van verkoping verskaf word. Vendusiekoste betaalbaar op dag van verkoping, sal as volg bereken word. 5% (Vyf persent) op die opbrengs van die verkoping tot 'n prys van R10 000 (Tien Duisend Rand) en daarna 2,50% (Twee en 'n half persent) tot 'n maksimum fooi van R5 000,00 (Vyf Duisend Rand). Minimum fooie R30,00 (Dertig Rand).

Gedateer te Johannesburg hierdie 7de dag van Oktober 1987.

Botha Moll & Vennote, 9de Verdieping, Atkinson Huis, Eloffstraat 24, Posbus 1588, Johannesburg. Tel: 331-6521. Verw: Rossouw/ jv/04/A010/088.

Saak 10127/87

IN DIE HOOGGEREGSHOF VAN SUID-AFRIKA

(Transvaalse Provinsiale Afdeling)

In die saak tussen **Sambou Nasionale Bourvereniging**, Eiser, en **Chris Engelbrecht**, Verweerder

Kennis word hiermee gegee dat ingevolge 'n uitspraak van die Hooggeregshof van Suid-Afrika, Transvaalse Provinsiale Afdeling, in bogemelde saak op die 14de dag van Julie 1987 en ter uitvoering van 'n lasbrief tot uitwinning sal die Adjunk-Balju op die 4de dag van November 1987 om 10h00 te die kantore van die Adjunk-Balju, Strubenstraat 142, Pretoria, verkoop:

Sekere: Deel No. 30 soos getoon en vollediger beskryf op Deelplan No. SS.200/85 in die gebou of geboue bekend as Demakot met straatadres te Demakotwoonstelle 502, Kotzestraat, Sunnyside.

Groot: 31 (Een en Dertig) vierkante meter.

Die eiendom is verbeter en bestaan uit:

1 Kamer, kombuis, badkamer en toilet.

Die koper moet 'n deposito van 10% van die koopprys, Adjunk-Balju se fooie en agterstallige belasting betaald op die dag van die verkoping, die balans betaalbaar teen transport en verseker te word deur 'n waarborg van 'n Bank of Bouvereniging wat deur die Eiser se prokureur goedgekeur is, die waarborg aan die Adjunk-Balju binne 14 (Veertien) dae na datum van die verkoping verstrek te word.

Gemelde eiendom sal verkoop word op die voorwaardes wat gelees sal word deur die Adjunk-Balju ten tye van die verkoping, welke verkoping nagegaan kan word by die kantore van die Adjunk-Balju.

Geteken te Pretoria hierdie 5de dag van Oktober 1987.

Dyason Odendaal & Van Eeden, Prokureurs vir Eiser, 2de Verdieping, Lepontgebou, Kerkstraat-Oos 451, Pretoria. (Verw: Mnr. Willems/ed, Tel: 325-2600.)

Saak 3612/86

IN DIE LANDDROSHOF VIR DIE DISTRIK VAN RANDFONTEIN GEHOU TE RANDFONTEIN

In die saak tussen **Carlos D. Gouveia M. de Menezes**, Eiser, en **B. C. Jones**, Verweerder

Ingevolge uitspraak van die Landdros van Randfontein, en Lasbrief tot Geregtelike verkoop, met datum 17 Desember 1986, sal die ondervermelde eiendom op die 12de dag van November 1987, om 10h00 by Lochstraat 7, Meyerton aan die hoogste bieder geregtelik verkoop word, naamlik:

Erf 740 Henley-On-Klip, Registrasie Afdeling I.R., Transvaal.

'n Leë erf ten opsigte waarvan geen waarborg gegee kan word nie.

Voorwaardes:

10% van die Koopprys kontant op die dag van verkoop en die balans teen registrasie van Transport, verseker te word deur 'n goedgekeurde Bank- of Bougenootskap waarborg gelewer te word binne 14 (veertien) dae daarna.

Die Voorwaardes van Verkoop mag gedurende kantoorure by die kantore van die Geregsbode te Lochstraat 7, Meyerton, nagesien word.

Datum: 1 Oktober 1987.

Truter Crous & Wiggill, Iurisgebou, Sutherlandstraat, Randfontein.

Case 3519/1987

IN THE MAGISTRATE'S COURT FOR THE DISTRICT OF WITBANK HELD AT WITBANK

In the matter between **SA Permanent Building Society** Plaintiff, and **P. J. W. H. van der Merwe**, Defendant

1. Kindly take notice that the following property namely: Portion 61 (a Portion of Portion 33) of the farm Klipfontein 322 Registration Division JS Transvaal;

Measuring: 4 100 square metres; shall be sold in execution on: 30th October 1987 at 10.00 a.m.

2. The sale shall be held at the Magistrate's Court, Delville Street, Witbank.

3. Subject to the provisions of Section 66 (2) of the Magistrate's Court Act No. 21 of 1944, the sale shall be without reserve and the property shall be sold to the highest bidder.

4. The purchase price of the property shall be paid as follows:

a) A deposit of 10% in cash at the conclusion of the sale.

b) The balance of the purchase price shall be paid in cash or secured by an approved Bankers of Building Society guarantee, payable against registration of transfer. Such guarantee shall be furnished within thirty (30) days from date of sale.

5. The property and any improvements thereon shall be sold "voetstoots".

Dated at Witbank this 1st day of October 1987.

I. Schech & Son, Attorneys for Plaintiff, SA Perm Building, President Avenue, P.O. Box 137, Witbank.

IN THE MAGISTRATE'S COURT FOR THE DISTRICT OF BENONI HELD AT BENONI

In the matter between **United Building Society**, Plaintiff, and **Jacob Dedeni Mokoena**, Defendant

In pursuance of a Judgment in the Court of the Magistrate of Benoni and Writ of Execution dated the 8th July 1987 the property listed hereunder will be sold in execution on 11th November 1987 at 11h00 at the Magistrate's Court, Harpur Avenue, Benoni to the highest bidder.

Certain: Lot 383, Daveyton Extension 2 Township, General Plan No. L141/1984 is held by Leasehold Title No. TL 25150/1985.

Situate at: 383 Mathewson Street, Daveyton Extension 2, Benoni.

Conditions of Sale

- (a) The Sale will be held by public auction and without reserve and will be voetstoots.
- (b) Immediately after the Sale the Purchaser shall sign the Conditions of Sale which can be inspected at the Messenger of the Court's office.
- (c) The Purchaser shall pay all amounts necessary to obtain transfer of the property, including all costs of transfers, transfer duty, rates, taxes, licences, sanitary fees, interest etc.
- (d) The purchase price shall be paid as to 10 (ten per centum) thereof or R300,00 (Three hundred Rand) whichever is the greater, on the date of the sale, and the unpaid balance, together with interest on the full amount of the Judgment Creditor's claim at the rate of 14% per annum to date of payment, within 14 days to be paid or secured by a Bank or Building Society guarantee.
- (e) The property shall be sold subject to any existing tenancy.
- (f) Failing compliance with the provisions of the Conditions of sale, the Purchaser shall forfeit for the benefit of the Execution Creditor the deposit referred to in (d) above without prejudice to any claim against him for damages.

Dated at Benoni this 2nd day of October 1987.

Edelstein Kahn Connack & Muller, Attorneys for Execution Creditor, Cedvic House, 94 Prince's Avenue (off Bunyan St), Benoni.

Case 64275/85

IN THE MAGISTRATE'S COURT FOR THE DISTRICT OF JOHANNESBURG HELD AT JOHANNESBURG

In the matter between **Formscraft (Pty) Ltd Acc. No.: 00239-58176**, Plaintiff, and **Joe van Vuuren t/a Blue Chip Inc**, Defendant

Pursuant to a Judgment of the above Honourable Court, dated the 27th day of October 1986, the undermentioned immovable property will be sold in execution by public auction to the highest bidder at 10h00 on the 30th October 1987, in front of the Court Building, Fox Street Entrance, Johannesburg pursuant to a warrant of execution dated the 14/11/86.

Description: Erf 609, Robertsham, Johannesburg.

Town Planning Zone: Residential.

Group Area: White.

Known as: 1 Gerald Street, Robertsham, Johannesburg.

Terms: The purchase price shall be paid as ten per cent (10%) thereof on the day of the sale and the unpaid balance together with interest thereon to date of registration of transfer, shall be paid or secured by an unconditional or approved Bank or Building Society guarantee within (14) (Fourteen) days of the date of sale to Messenger of the Court. The full Conditions of Sale may be inspected at the office of the Messenger of the Court, 100 Sheffield Street, Turffontein, Johannesburg.

Dated at Johannesburg on this 3rd day of October 1987.

(Sgd) E. Gatzouris, for Salomon-Friedman, 1st and 2nd Floors, SFB Chambers, 133 Marshall Street, Johannesburg. Tel: 331-0312. Ref: Mr Georgiev.

To: The Messenger of the Court Johannesburg South.

Case 6883/87

IN THE SUPREME COURT OF SOUTH AFRICA

(Witwatersrand Local Division)

In the matter between **United Building Society Limited**, Plaintiff, and **Goodenough Wallace Nkomo**, Defendant

In Execution of a Judgment of the Supreme Court of South Africa, (Witwatersrand Local Division) in the above-mentioned suit, a Sale without Reserve will be held at the office of the Deputy Sheriff, Johannesburg at 131 Marshall Street, Johannesburg on Thursday the 12th day of November 1987 at 10.00 am of the undermentioned property of the Defendant on the Conditions to be read out by the Auctioneer at the time of the Sale, which conditions will lie for inspection at the offices of the Deputy Sheriff, Johannesburg prior to the sale.

The Right of Leasehold in respect of Site No. 3185 Moroka Village/Township.

The following information is furnished *re* the improvements, though in this respect nothing is guaranteed:

A Dwelling House consisting of Lounge, Dining Room, Two Bedrooms, Bathroom and w.c., Kitchen.

Terms: 10 % of the purchase price in cash on the day of the sale, the balance payable against registration of Transfer, to be secured by a Bank or Building Society or other acceptable guarantee to be furnished within 14 days from the date of sale.

Auctioneer's charges, payable on the day of the sale, to be calculated as follows: 5 % on the proceeds of the sale up to a price of R10 000,00 and thereafter 2,5 % up to a maximum fee of R5 000,00, minimum charges R30,00.

Dated at Johannesburg on the 29th day of September 1987.

Bowman Gilfillan Hayman Godfrey Inc., Plaintiff's Attorneys, 21st Floor, United Towers, 160 Main Street, Johannesburg. Tel: 28-5120. Ref: W. K. Rush/GGLIT 737909.

IN THE SUPREME COURT OF SOUTH AFRICA

(Witwatersrand Local Division)

In the matter between **United Building Society Limited**, Plaintiff, and **Ellen Nonyane**, Defendant

In Execution of a Judgement of the Supreme Court of South Africa, (Witwatersrand Local Division) in the above-mentioned suit, a Sale without Reserve will be held at the office of the Deputy Sheriff, Johannesburg at 131 Marshall Street, Johannesburg on Thursday the 12th day of November 1987 at 10.00 am of the undermentioned property of the Defendant on the Conditions to be read out by the Auctioneer at the time of the Sale, which conditions will lie for inspection at the offices of the Deputy Sheriff, Johannesburg prior to the sale.

The Right of Leasehold in respect of Lot No. 1168 Protea North Village/Township.

Measuring 232 Square Metres.

The following information is furnished *re* the improvements, though in this respect nothing is guaranteed:

Lounge, Diningroom, 2 Bedrooms, Bathroom and wc, Kitchen.

Terms: 10 % of the purchase price in cash on the day of the sale, the balance payable against registration of Transfer, to be secured by a Bank or Building Society or other acceptable guarantee to be furnished within 14 days from the date of sale.

Auctioneer's charges, payable on the day of the sale, to be calculated as follows: 5 % on the proceeds of the sale up to a price of R10 000,00 and thereafter 2,5 % up to a maximum fee of R5 000,00, minimum charges R30,00.

Dated at Johannesburg on the 29th day of September 1987.

Bowman Gilfillan Hayman Godfrey Inc., Plaintiff's Attorneys, 20th Floor, United Towers, 160 Main Street, Johannesburg. Tel: 28-5120. Ref: W. K. Rush/GGLIT 742506.

Case 4796/87

IN THE SUPREME COURT OF SOUTH AFRICA

(Witwatersrand Local Division)

In the matter between **United Building Society Limited**, Plaintiff, and **Jacobus Michael Henning**, Defendant

In Execution of a Judgement of the Supreme Court of South Africa, (Witwatersrand Local Division) in the above-mentioned suit, a Sale without Reserve will be held at the office of the Deputy Sheriff, Johannesburg at 131 Marshall Street, Johannesburg on Thursday the 12th day of November 1987 at 10.00 am of the undermentioned property of the Defendant on the Conditions to be read out by the Auctioneer at the time of the Sale, which conditions will lie for inspection at the offices of the Deputy Sheriff, Johannesburg prior to the sale.

Erf 2166 Newlands Township, Registration Division 1 Q, Transvaal, being 27 Shortmarket Street Newlands Johannesburg.

Measuring 342 Square Metres.

use Zone: Residential 1.

The following information is furnished *re* the improvements, though in this respect nothing is guaranteed:

Entrance Hall, Lounge, Diningroom, 2 Bedrooms, Sunroom, Bathroom and w c Kitchen, Garage, Servant's Room and w c.

Terms: 10 % of the purchase price in cash on the day of the sale, the balance payable against registration of Transfer, to be secured by a Bank or Building Society or other acceptable guarantee to be furnished within 14 days from the date of sale.

Auctioneer's charges, payable on the day of the sale, to be calculated as follows: 5 % on the proceeds of the sale up to a price of R10 000,00 and thereafter 2,5 % up to a maximum fee of R5 000,00, minimum charges R30,00.

Dated at Johannesburg on the 30th day of September 1987.

Bowman Gilfillan Hayman Godfrey Inc., Plaintiff's Attorneys, 20th Floor, United Towers, 160 Main Street, Johannesburg. Tel: 28-5120. Ref: W. K. Rush/GGLIT 785365.

Case 38847/87

IN THE MAGISTRATE'S COURT FOR THE DISTRICT OF PRETORIA HELD AT PRETORIA

In the matter between **United Building Society Limited**, Plaintiff, and **Charmaine Poolman**, Defendant

A sale in execution of the property described hereunder will be held in front of the Magistrate's Court, Pretorius Street, Pretoria at 11h00 on 28 October 1987:

(a) Section 1 as shown and more fully described on sectional plan No. SS 181/86 in the building or buildings known as "Jubilee Park Mansions" of which the floor area, according to the said sectional plan is 45 square metres in extent; and

(b) an undivided share in the common property in the land and building or buildings as shown and more fully described on the said sectional plan, apportioned to the said section in accordance with the participation quota of the said section, held under certificate of registered sectional title No. ST 181/86(1)(Unit) dated 28 July 1986.

The following particulars are furnished but not guaranteed:

This fairly neatly kept unit, known as Flat No. 1 Jubilee Park Mansions, c/o Mear and Kotze Streets, Sunnyside, Pretoria, is situated in a good, White residential area.

Improvements Comprise

This flat consists of a lounge-diningroom, kitchen, 1 bedroom and 1 bathroom and toilet, wall to wall carpets and 1 built-in cupboard.

A substantial Building Society bond can be arranged for an approved purchaser.

The conditions of sale may be inspected at the office of the Messenger of the Court, (Pretoria South) Room 1, Erasmusrand Centre, cnr Rigel Avenue and Buffelsdrift Street, Erasmusrand, Pretoria.

6 October 1987.

J. A. Alheit, for MacRobert, De Villiers & Hitge Inc., 501 United Building, 263 Andries Street, Pretoria. Tel: 28-6770. NI/145132/J. A. Alheit/be.

Saak 1917/87

IN DIE LANDDROSHOF VIR DIE DISTRIK VAN KEMPTON PARK GEHOU TE KEMPTON PARK

In die saak tussen **Natal Bouvereniging**, Eiser, en **Iain Bruce Basson**, Verweerder

Ingevolge 'n vonnis toegestaan en 'n Lasbrief vir Eksekusie gedateer die 8ste Mei, 1987 uitgereik in die Landdroshof, Kempton Park word die volgende eiendom deur die Geregsbode verkoop by die Geregsbode Kantore, Parkstraat 10, Kempton Park aan die hoogste bieder op Donderdag die 12de November, 1987 om 10h00.

Erf 2765, Blich Acres Uitb. 17, Kempton Park, Registrasie Afdeling IR Transvaal.

Groot: 841 (Agt Honderd Een en Veertig) vierkante meter;

Geleë te: Watertrapperstraat 70, Birch Acres Uitb. 17, Kempton Park.

Gehou: Onder Akte van Transport T1312/86.

Voorwaardes van Verkoop

1. Die eiendom sal verkoop word sonder reserweprys aan die hoogste bieder en sal onderworpe wees aan die bepalinge en voorwaardes van die Landdroshowe Wet en Reëls daaronder geproklameer en van die bepalinge van die Titellakte, insover dit van toepassing mag wees.

2. Die volgende verbeterings op die eiendom word aangekondig maar geen waarborg in verband daarmee word verskaf nie:

Sitkamer, Eetkamer, 3 Slaapkamers, Studeerkamer, 1 ½ Badkamer, 2 Toilette, 1 Afdak, alles onder teëldak, eiendom is omhein.

3. Hierdie verkoping is onderhewig aan 'n huurooreenkoms wat verstryk op 31 Maart 1988.

4. *Betaling*: Die Koopprijs sal betaalbaar wees synde 10% daarvan op die dag van verkoping aan die Geregsbode en die balans tesame met rente daarop teen 13,5% tot datum van registrasie van oordrag by wyse van 'n Bank- of Bouverenigingwaarborg, gelewer te word binne 21 dae vanaf datum van Verkoping van hierdie eiendom.

5. *Voorwaardes*: Die volle voorwaardes van Verkoping lê vir insae by die Kantoor van die Geregsbode te Kempton Park.

(Get) J. H. B. Schnetler, vir J. H. Badenhorst-Schnetler, 3de Vloer, Hees en Van Loggerenberggebou, Longstraat 23, Posbus 9, Kempton Park. 975-7100. JHBS/g1/N59.

Case 6726/87

IN THE MAGISTRATE'S COURT FOR THE DISTRICT OF JOHANNESBURG HELD AT JOHANNESBURG

Between **Natal Building Society**, Plaintiff, and **Ramesh Chunilal Chhagan**, Defendant

In pursuance of a Judgment in the Court for the Magistrate of Johannesburg and Writ of Execution dated the 19th day of June, 1987, the property listed hereunder will be sold in execution on Friday the 6th day of November, 1987, at 10.00 a.m. in front of the Magistrate's Court, Westonaria, to the highest bidder.

Certain: Erf 2267 Lenasia South Township, Registration Division I.Q. Transvaal;

Measuring 600 (six hundred) square metres;

Held under Deed of Transfer No. T3213/1984 and situate at 2267 Orchid Street, Second Off Starling Street, Lenasia South, Johannesburg.

The following improvements are reported to be on the property, but nothing is guaranteed.

A single storey dwelling built of brick, roofed with tile, comprising lounge, dining room, kitchen, 3 bedrooms, 2 bathrooms, 2 w.c.'s and entrance way. Outbuildings consist of one garage and outside w.c.

Terms:

1. 10% (Ten Per Cent) of the purchase price in cash on the day of the sale, the balance together with interest thereon at 15% p.a. payable against registration of Transfer, to be secured by a Bank or Building Society or other acceptable guarantee to be furnished within twenty-one (21) days from the date of sale. (A substantial Building Society loan can be raised for an approved purchaser).

2. Auctioneer's charges, payable on the day of sale, to be calculated as follows: 4% (Four Per Cent) on the proceeds of the sale.

Conditions of sale:

1. The property shall be sold without reserve and to the highest bidder and shall be subject to the terms and conditions of the Magistrate's Court Act and the rules made thereunder and of the Title Deeds in so far as these are applicable.

2. The full Conditions of Sale may be inspected at the office of the Messenger of the Court.

Moodie & Robertson, Plaintiff's Attorneys, 8th Floor, African Life Centre, Cor. Eloff and Commissioner Streets, Johannesburg. Tel: 28-2636. Ref: Mr Johanson.

Case 15680/87

IN THE SUPREME COURT OF SOUTH AFRICA

(Witwatersrand Local Division)

In the matter between **United Building Society Limited**, Plaintiff, and **Thandeka Mahlali**, Defendant

In execution of a Judgement of the Supreme Court of South Africa, (Witwatersrand Local Division) in the above-mentioned suit, a Sale without Reserve will be held at the office of the Deputy Sheriff, Johannesburg at 131 Marshall Street, Johannesburg on Thursday the 12th day of November 1987 at 10. a.m. of the undermentioned property of the Defendant on the Conditions to be read out by the Auctioneer at the time of the Sale, which conditions will lie for inspection at the offices of the Deputy Sheriff, Johannesburg prior to the sale.

The Right of Leasehold in respect of Lot No. 1345 Protea North Village/Township.

Measuring 242 square metres.

The following information is furnished *re* the improvements, though in this respect nothing is guaranteed:

A dwelling house consisting of: Entrance hall, lounge, dining room, 3 bedrooms, 2 bathrooms with toilets, kitchen.

Terms: 10% of the purchase price in cash on the day of the sale, the balance payable against registration of Transfer, to be secured by a Bank- or Building Society- or other acceptable guarantee to be furnished within 14 days from the date of sale.

Auctioneer's charges, payable on the day of the sale, to be calculated as follows: 5% on the proceeds of the sale up to a price of R10 000,00 and thereafter 2,5% up to a maximum fee of R5 000,00 minimum charges R30,00.

Dated at Johannesburg on the 29th day of September 1987.

Bowman Gilfillan Hayman Godfrey Inc., Plaintiff's Attorneys, 20th Floor, United Towers, 160 Main Street, Johannesburg. Tel: 28-5120. Ref: WK Rush/GGLIT 781156.

IN THE SUPREME COURT OF SOUTH AFRICA

(Witwatersrand Local Division)

In the matter between **United Building Society Limited**, Plaintiff, and **Dennis Masuku**, Defendant

In execution of a judgement of the Supreme Court of South Africa, (Witwatersrand Local Division) in the above-mentioned suit, a Sale without Reserve will be held at the office of the Deputy Sheriff Johannesburg at 131 Marshall Street, Johannesburg on Thursday the 12th day of November 1987 at 10.00 a.m. of the undermentioned property of the Defendant on the Conditions to be read out by the Auctioneer at the time of the Sale, which conditions will lie for inspection at the offices of the Deputy Sheriff, Johannesburg prior to the sale.

The Right of Leasehold in respect of Site No. 1206 Chiawelo Village/Township.

The following information is furnished *re* the improvements, though in this respect nothing is guaranteed:

A dwelling house consisting of a lounge, two bedrooms, kitchen, servant's room, bathroom/wc.

Terms: 10% of the purchase price in cash on the day of the sale, the balance payable against registration of Transfer, to be secured by a Bank- or Building Society- or other acceptable guarantee to be furnished within 14 days from the date of sale.

Auctioneer's charges, payable on the day of the sale, to be calculated as follows: 5% on the proceeds of the sale up to a price of R10 000,00 and thereafter 2,5% up to a maximum fee of R5 000,00, minimum charges R30,00.

Dated at Johannesburg on the 29th day of September 1987.

Bowman Gilfillan Hayman Godfrey Inc., Plaintiff's Attorneys, 20th Floor, United Towers, 160 Main Street, Johannesburg. Tel: 28-5120. Ref: WK Rush/GGLIT 711402.

Case 7540/87

IN THE SUPREME COURT OF SOUTH AFRICA

(Witwatersrand Local Division)

In the matter between **The Liquidators of A A Mutual Insurance Association Limited**, Plaintiff, and **Jose Manuel Goncalves Bessa Gomes**, First Defendant and **Maria Manuela Gomes**, Second Defendant

In execution of a Judgement of the Supreme Court of South Africa (Witwatersrand Local Division) in the above-mentioned suit a Sale without reserve will be held at the office of the Deputy Sheriff, at 131 Marshall Street, Johannesburg on the 12th day of November 1987 at 10h00 of the undermentioned property of the Defendant on the Conditions to be read out by the Auctioneer at the time of the sale which conditions will lie for inspection at the offices of the Deputy Sheriff, Johannesburg prior to the sale.

(Short description of property, situation, and street number):

Erf 137 Oakdene Extension 1 Township Registration Division I R Transvaal situate at 26 Swartberg Drive, Oakdene Extension 1, Johannesburg.

Measuring 1 289 square metres.

Use Zone: Residential 1.

The following information is furnished *re* the improvements, though in this respect nothing is guaranteed. A partially built dwelling house with no floors, windows, doors, ceilings or roof.

Terms: 10% (Ten per cent) of the purchase price in cash on the day of the sale, the balance payable against registration of Transfer, to be secured by a Bank- or Building Society- or other acceptable guarantee to be furnished within 14 (fourteen) days from the date of sale.

Auctioneers charges, payable on the day of sale, to be calculated as follows: 5% (Five per cent) on the proceeds of the sale up to a price of R10 000,00 (Ten Thousand Rand) and thereafter 2½% (two and a half per cent) up to a maximum fee of R5 000,00 (Five thousand rand). Minimum charges R30,00 (Thirty Rand).

Dated at Johannesburg on this the 30th day of September 1987.

Bowman Gilfillan for Hayman Godfrey Incorporated, Plaintiff's Attorneys, 20th Floor, United Towers, 160 Main Street, Johannesburg, 2001. Tel. 285 120. Ref. Mr W K Rush/jm/KR 775637.

Case 12280/86

IN THE SUPREME COURT OF SOUTH AFRICA

(Witwatersrand Local Division)

In the matter between **United Building Society**, Plaintiff, and **Thandukwazi Sunford Mthethwa**, Defendant

In execution of a judgment of the Supreme Court of South Africa, (Witwatersrand Local Division) in the above-mentioned suit, a Sale without Reserve will be held at the office of the Deputy Sheriff, Randburg 6 Elna Randhof, corner Blairgowrie Drive and Selkirk Avenue, Blairgowrie, Randburg on Tuesday, the 3rd day of November 1987, at 10.00 a.m., of the undermentioned property of the Defendant on the Conditions to be read out by the Auctioneer at the time of the Sale, which Conditions will lie for inspection, prior to the sale, at the offices of the Deputy Sheriff, Randburg.

(Short description of property situation, and street number):

The Right of Leasehold in respect of Site No. 57 Alexandra Ext. 1 township.

The following information is furnished *re* the improvements, though in this respect nothing is guaranteed:

The house consists of an entrance hall, lounge, diningroom, kitchen, bathroom, toilet, 3 bedrooms. There is also a single garage.

Terms: 10% (Ten per cent) of the purchase price in cash on the day of the sale, the balance payable against registration of Transfer to be secured by a Bank- or Building Society -or other acceptable guarantee to be furnished within 14 (fourteen) days from the date of sale.

Auctioneer's charges, payable on the day of sale, to be calculated as follows: 5% (five per cent) on the proceeds of the sale up to a price of R10 000,00 (Ten thousand Rand) and thereafter 2½% (two-and-a-half per cent) up to a maximum fee of R5 000,00 (Five thousand Rand) Minimum charge R30,00 (Thirty Rand).

Date: 1 October 1987.

Langstaffe Bird and Company, Plaintiff's Attorneys, Langstaffe Bird and Company, 8th Floor, United Towers, 160 Main Street, Johannesburg. Ref: Mr E. Letty. Tel: 337-3993.

Case 6666/87

IN THE MAGISTRATE'S COURT FOR THE DISTRICT OF JOHANNESBURG HELD AT JOHANNESBURG

In the matter between **Fibreflex Pools (S.A.) (Pty) Limited**, Plaintiff, and **R. M. R. East**, Defendant

In pursuance of a judgment of the Magistrate of Johannesburg, granted on the 8th day of April 1987 and a warrant of execution issued in pursuance thereof the right, title and interest in the undermentioned property will be sold in execution on Friday, the 30th day of October 1987 at the Fox Street entrance of the Johannesburg Magistrate's Court Building, to the highest bidder namely:

Erf 103 Malvern (Johannesburg) Township Registration Division I.R. Transvaal situate at 3 Mars Street, Malvern, Johannesburg.

In extent: 495 (four hundred and ninety five) square metres.

Held by Ronnie East under deed of transfer No. 6605/1976.

The property can be described as follows:

Dwelling House consisting of a lounge, 3 bedrooms, kitchen, bathroom and toilet, guest toilet, store-room, carport and swimming pool.

Terms: The purchase price shall be paid as to 10% thereof on the day of the sale and the unpaid balance together with interest thereon as stated in the Conditions of Sale, to date of registration of transfer shall be paid or secured by the delivery of an acceptable Bank or Building Society guarantee within 30 (thirty) days of the date of sale. The full and complete Conditions of Sale which will be read immediately prior to the sale may be inspected to the offices of the Messenger of Court, Johannesburg East, A4 Sanlam Industrial Park, Prop Street, Selby, Johannesburg.

(Sgd) H. B. Salmon for Edgar Salmon & Salmon, Plaintiff's Attorneys, 801 Kelhof, 112 Pritchard Street, Johannesburg. P.O. Box 4199, Tel: 23-9501. Ref: Mr H. Salmon/as.

Saak 5509/87

IN DIE LANDDROSHOF VIR DIE DISTRIK VAN KEMPTON PARK GEHOU TE KEMPTON PARK

In die saak tussen **United Bouvereniging Beperk**, Eiser, en **Andre Johan van Coller**, Verweerder

Ingevolge 'n vonnis toegestaan in die Landdroshof en 'n Laasbrief vir Eksekusie gedateer 7 September 1987 uitgereik deur die Hof te Kempton Park, sal die volgende eiendom verkoop word deur die Geregsbode by die Geregsbode kantoor, Parkstraat 10, Kempton Park aan die hoogste bieder op Woensdag 18 November 1987 om 11h00.

Erf: 112 Birchleigh Noord Uitbreiding 3 Dorpsgebied Registrasie Afdeling I.R. Transvaal;

Groot: 1 089 (eenduisend nege en tagtig) vierkante meter;

Bekend as: 24 Hermostraat, Birchleigh Noord X3 Kempton Park.

Voorwaardes van Verkoop:

1. Die eiendom sal verkoop word sonder reserwe aan die hoogste bieder en sal onderworpe wees aan die terme en voorwaardes van die Landdroshof Wet en Reëls daaronder geproklameer en van die terme van die Titelaktes, in so ver dit van toepassing mag wees.

2. Die volgende verbeterings op die eiendom word aangekondig maar geen waarborg in verband daarmee word verskaf nie;

Leë erf.

3. Terme: Die koopprys sal betaalbaar wees synde 10% daarvan op die dag van die verkoping aan die Geregsbode en die balans, tesame met rente op die volle koopprys vanaf datum van verkoping tot datum van registrasie van transport teen 'n rentekoers van 14,50% per jaar sal binne veertien (14) dae aan die Geregsbode betaal word of gedek word deur 'n goedgekeurde Bank- of Bougenootskapswaarborg.

4. Voorwaardes: Die volle voorwaardes van verkoping lê ter insae by die kantoor van die Geregsbode te Kempton Park.

(Get) C. A. McKenzie vir Botha Massyn & McKenzie, Prokureur vir Eiser, 9de Vloer, United Gebou, Kempton Park, 1620.

Case 1495/86

IN THE SUPREME COURT OF SOUTH AFRICA

(Transvaal Provincial Division)

In the matter between **Barclays National Bank Limited**, Plaintiff, and **Claude Findlay de Lange**, Defendant

In execution of a judgment granted by the Supreme Court of South Africa, Natal Provincial Division on Wednesday the 25th March 1987 in the above-named suit, the following immovable properties will be sold by public auction by the Deputy Sheriff of the Supreme Court of South Africa for the District of Pietermaritzburg on the steps of his office at 176 Loop Street, Pietermaritzburg, Natal at 9.00 a.m. on Saturday the 31st October 1987 on conditions which will be read out by the Deputy Sheriff before the sale, and which conditions are in the possession of the Deputy Sheriff and may be inspected at office at 176 Loop Street, Pietermaritzburg, Natal, namely:

(a) Sub 4 of Lot 2037 Pietermaritzburg, situate in the City of Pietermaritzburg, Administrative District of Natal, in extent One Thousand One Hundred and Seventy One (1 171) square metres;

(b) Sub 4 of Lot 2038 Pietermaritzburg, situate in the City of Pietermaritzburg, Administrative District of Natal, in extent Two Hundred (200) square metres, which properties are physically situate at 379 Greyling Street, Pietermaritzburg and which properties are held by Claude Findlay de Lange, the abovenamed Defendant under and by virtue of Deed of Transfer Number T16112/1970 dated 8 October 1970.

Improvements: Without constituting a warranty of any nature, the properties have been improved by the erection thereon of five (5) mini factories with toilet facilities and two (2) offices with toilet and kitchen facilities.

Zoning: The property is zoned for General Industrial Area.

Group Area: The properties are situate within a Coloured Area and accordingly no bids can be accepted by or on behalf of any person who is not a member of that Group unless such person exhibits to the auctioneer at the sale the requisite permit entitling and authorising such person to acquire the property.

Terms: The purchase price will be payable subject to the Conditions of sale, as follows:

(a) Ten per cent of the purchase price together with the Deputy Sheriff's commission on the sale to be paid immediately in cash on the date of sale.

(b) All current and arrear rates, taxes, electrical, sanitary, water and other fees or charges to be paid in cash within Seven (7) Days of the date of sale together with costs of transfer and transfer duty.

(c) The balance of the purchase price together with interest at the rate of 19.5 per cent per annum compounded monthly in advance on the amount referred to in the conditions of Sale from date of sale to date of transfer both days inclusive, to be secured by an acceptable guarantee to be furnished within Fourteen (14) Days after the date of sale.

M. E. Cajee for Cajee & Associates, Plaintiff's Attorneys; G. N. Pudney signed on behalf of M. E. Cajee by MacRobert De Villiers & Hitge Inc., First Floor, 108 Retief Street, Pietermaritzburg.

IN THE MAGISTRATE'S COURT FOR BRONKHORSTSPRUIT HELD AT BRONKHORSTSPRUIT

In the matter between **Natal Building Society Limited**, Plaintiff, and **Catharina Susanna Joubert**, Defendant

Sale in execution to be held in front of the Magistrate's Court, Bronkhorstspuit at 10 a.m. on the 30th day of October, of: Erf 708 situate in the Township of Bronkhorstspuit Extension I Registration Division J.R. Transvaal;

Measuring 1 050 square metres;

The property is known as 62 General Louis Botha Street, Bronkhorstspuit in a good residential area.

Improvements which are not guaranteed comprise a sound brick under tile dwelling of lounge, diningroom, three bedrooms, kitchen, two bathrooms, shower and two w.c.'s wall to wall caprets and front verandah. Outbuildings comprise garage, servant's room, laundry and w.c.

A substantial Building Society Bond can be arranged for an approved Purchaser.

Terms: 10% in cash on the day of sale and the balance against transfer to be secured by an approved guarantee to be furnished within 21 days after the date of sale.

Conditions of Sale can be inspected at the Offices of the Messenger of the Court, Bronkhorstspuit.

8 October 1987.

Solomon & Nicolson Inc., P.O. Box 645, Pretoria. Ref. N.B.S. 1166.

Saak 6126/87

IN DIE HOOGGEREGSHOF VAN SUID-AFRIKA

(Transvaalse Provinsiale Afdeling)

In die saak tussen **Santambank Beperk**, Eiser, en **André Lotter**, Verweerder

Ter uitwinning van 'n vonnis van die Hooggeregshof van Suid-Afrika (Transvaalse Provinsiale Afdeling) sal in bogemelde saak 'n verkoping gehou word te die Landdroshofkantoor, Jan van Riebeeckstraat, Swarttruggens op die 30ste dag van Oktober 1987 om 10h00 van die ondervermelde eiendom van die Verweerder wat deur die Venuaafslaer gelees sal word ten tye van die verkoping en welke voorwaarde by die kantore van die Adjunk-Balju, Swarttruggens voor die verkoping ter insae sal lê.

Resterende Gedeelte van Gedeelte 11 (gedeelte van Gedeelte 3) van die plaas Koornfontein 385 Registrasie Afdeling JP Transvaal.

Groot: 110,2424 Hektaar.

Gehou kragtens Akte van Transport T7416/86.

Daar is verbeterings op die eiendom wat bestaan uit: —Een 3 slaapkamerwoonhuis, 250 vierkante meter groot met 'n enkel motorhuis; —Een oop staalstoor van 120 vierkante meter; —8 Varkhokke, toegeruste boorgat; Geen verbeterings word egter gewaarborg nie.

Terme: Tien persent (10%) van die koopprys en afslaaersgelde in kontant op die dag van die verkoping en die balans teen registrasie van transport. Ten opsigte van die balans moet 'n Bank of Bougenootskapswaarborg of ander aanneembare waarborg binne 21 dae vanaf datum van verkoping verskaf word.

Davis van der Stoep & Winsnes, Eiser se Prokureurs, 1e Vloer, Lougardia Gebou, Verwoerdburgstad. Tel: 663 1340. Verw. mnr vd Stoep/me/SSL109.

Case 65351/86

IN THE MAGISTRATE'S COURT FOR THE DISTRICT OF PRETORIA HELD AT PRETORIA

In the matter between **United Building Society Limited**, Plaintiff, and **Shauvette Properties (Pty) Limited**, 1st Defendant, **Nicolaas Leon Erwee**, 2nd Defendant, **Stephanus Sigismundus Carroll**, 3rd Defendant

A sale in execution of the property described hereunder will be held in front of the Magistrate's Court, Pretorius Street, Pretoria, at 11h00 on 28 October 1987.

Remaining Extent of Erf 350 situate in the township Hatfield, Registration Division J R Transvaal;

Measuring: 850 square metres;

The following particulars are furnished but not guaranteed:

This property, known as 485 Glyn Street, Hatfield, Pretoria, is an old type dwelling situated near the University in a good, White residential area.

Improvements Comprise:

1. Brick dwelling under iron roof consisting of lounge, kitchen, 9 bedrooms and 2 bathrooms.

Construction includes "Compo"-board ceilings, vinyl tile and carpeted floors, built-in cupboards and a hot water system.

2. 2 carports, servants room and toilet.

A substantial Building Society bond can be arranged for an approved purchaser.

The conditions of sale may be inspected at the office of the Messenger of the Court (Southern area), 1st Floor, Erasmusrand Centre, cnr. Rigel Avenue and Buffeldrift Street, Erasmusrand, Pretoria.

2 October 1987.

J. A. Albeit, for MacRobert, De Villiers & Hitge Inc., 501 United Building, 263 Andries Street, Pretoria. Tel. 28-6770. Ref: N1/121036/mw.

Case 33449/87

IN THE MAGISTRATE'S COURT FOR THE DISTRICT OF PRETORIA HELD AT PRETORIA

In the matter between **United Building Society Limited**, Plaintiff, and **Barmer (Pty) Ltd**, Defendant

A sale in execution of the property described hereunder will be held in front of the Magistrate's Court, Pretorius Street, Pretoria at 11h00 on 28 October 1987:

(a) Section 1 as shown and more fully described on sectional plan No. SS 120/86 in the building or buildings known as "Bruce" of which the floor area, according to the said sectional plan is 115 square metres in extent; and

(b) an undivided share in the common property in the land and building or buildings as shown and more fully described on the said sectional plan, apportioned to the said section in accordance with the participation quota of the said section, held under certificate of registered sectional title No. ST 120/86(1)(Unit) dated 15 May 1986.

The following particulars are furnished but not guaranteed:

This property known as 1 Bruce, Loskop Street, Newlands, Pretoria, is situated in a good, White residential area.

Improvements Comprise

This dwelling consists of a lounge, diningroom, familyroom, kitchen, 2 bedrooms, 2 bathrooms, 2 w c's and a laundry with carpeted floors and built-in cupboards.

A substantial Building Society bond can be arranged for an approved purchaser.

The conditions of sale may be inspected at the office of the Messenger of the Court, (Pretoria South) Room 1, Erasmusrand Centre, c/o Rigel Avenue and Buffelsdrift Street, Erasmusrand, Pretoria.

8/10/87.

J. A. Alheit, for MacRobert, De Villiers & Hitge Inc., 501 United Building, 263 Andries Street, Pretoria. Tel: 28-6770. N1/142773/J. Alheit/pf.

Case 65965/86

IN THE MAGISTRATE'S COURT FOR THE DISTRICT OF PRETORIA HELD AT PRETORIA

In the matter between **United Building Society Limited**, Plaintiff, and **Barmer (Pty) Ltd**, Defendant

A sale in execution of the property described hereunder will be held in front of the Magistrate's Court, Pretorius Street, Pretoria at 11h00 on 28 October 1987:

(a) Section 2 as shown and more fully described on sectional plan No. SS 66/87 in the building or buildings known as "Meridy" of which the floor area, according to the said sectional plan is 102 square metres in extent; and

(b) an undivided share in the common property in the land and building or buildings as shown and more fully described on the said sectional plan, apportioned to the said section in accordance with the participation quota of the said section, held under certificate of registered sectional title No. ST 66/87(2)(Unit) dated 7 April 1987.

The following particulars are furnished but not guaranteed:

This property known as 233 Gloxinia Street, Newlands, Pretoria, is situated in a good, White residential area.

Improvements Comprise

This dwelling consists of a lounge, diningroom, familyroom, kitchen, 2 bedrooms, 2 bathrooms, 2 w c's and a laundry with carpeted floors and built-in cupboards.

A substantial Building Society bond can be arranged for an approved purchaser.

The conditions of sale may be inspected at the office of the Messenger of the Court, (Pretoria South) Room 1, Erasmusrand Centre, c/o Rigel Avenue and Buffelsdrift Street, Erasmusrand, Pretoria.

8/10/87.

J. A. Alehit, for MacRobert, De Villiers & Hitge Inc., 501 United Building, 263 Andries Street, Pretoria. Tel: 28-6770. N1/123045/J. Alheit/pf.

IN DIE HOOGGEREGSHOF VAN SUID-AFRIKA

(Transvaalse Provinsiale Afdeling)

In die saak tussen **Volkskas Beperk**, Eiser, en **Raymond de Haast**, Eerste Verweerder, **Werron Alwyn de Haast**, Tweede Verweerder

Ingevolge 'n Vonnis deur bogemelde Agbare Hof, op 10 Desember 1985 en 'n lasbrief vir eksekusie word die volgende onroerende eiendom op 4 November 1987 om 10h00 verkoop te die kantoor van die Adjunk-Balju te Strubenstraat 142, Pretoria aan die hoogste bieder:

1. Erf 2596 geleë in die dorpsgebied Wierdapark Uitb. 2, Registrasie Afdeling J.R. Transvaal.

Groot 1 050 (Eenduisend en Vyftig) vierkante meter.

Gehou kragtens Akte van Transport T 56297/84.

2. Hoewe 42 geleë in Mnandi Landbouhoewes, Registrasie Afdeling J.R. Transvaal.

Groot 4,0041 (Vier komma Nul Nul Vier Een) hektaar.

Gehou kragtens Akte van Transport T22233/75.

Die reserweprys is R3 214,00.

Terme en Voorwaardes:

Terme

Die koopprys sal wees 10 % (Tien Persent) daarvan by verkoping en die balans moet binne 10 dae verseker word by wyse van 'n bank- of buverenigingwaarborg.

Voorwaardes

Die volle voorwaardes van verkoping wat deur die Adjunk-Balju van Nylstroom onmiddellik voor die verkoping uitgelees sal word, sal ter insae lê by die kantoor van die Adjunk-Balju te Strubenstraat 142, Pretoria.

Geteken te Pretoria op hierdie dag van 1987.

Tim du Toit & Kie Ingelyf, Prokureurs vir Eiser, Volkskasgebou 1920, Strijdomplein, Pretoria. (Mnr. Coetzer, Tel: 325-2277/88.)

Saak 1714/87

IN DIE LANDDROSHOF VIR DIE DISTRIK VAN GERMISTON GEHOU TE GERMISTON

In die saak tussen **Die United Bouvereniging**, Eiser, en **Nicholas Valasis**, Verweerder

Ter uitvoerlegging van 'n vonnis van die Landdros van Germiston toegestaan op 4 Mei 1987 en 'n Lasbrief vir Eksekusie uitgereik in opvolging daarvan sal die ondergemelde eiendom in eksekusie verkoop word op Dinsdag, 24 November 1987 om 10h00 by die Landdroskantore Germiston, Presidentstraat, Germiston, aan die hoogste bieder naamlik:

'n Woonhuis geleë te Erf 546 Bedfordview Uitbreiding 108 Dorpsgebied, Registrasie Afdeling I.R. Transvaal;

Groot 1 983 (Een Duisend Nege Honderd Drie en Tagtig) vierkante meter;

Gehou kragtens Akte van Transport No. T25852/1986.

Die eiendom kan omskryf word soos volg:

Woonhuis geleë te Sugerbushweg 37, Morninghill, Bedfordview, bestaande uit; ingangsportaal, sitkamer, eetkamer, gesinskamer, 4 slaapkamers, 2 badkamers met toilet, kombuis, waskamer, 2 motorhuise, bediendekamer, stort met toilet en studeerkamer.

Terme:

10 % van die koopprys in kontant betaalbaar ten tye van die verkoping en die balans tesame met rente soos in die Verkoopvoorwaardes uiteengesit, moet verseker word deur; goedgekeurde Bank- of Bougenootskapswaarborg binne 14 (Veertien) dae vanaf datum van die verkoping. Volledige besonderhede van die Verkoopvoorwaardes wat onmiddellik voor die aanvang van die verkoop gelees word, is ter insae by die kantore van die Geregsbode, Germiston, te Argosy Huis 406, h/v President- en Spilsburystraat en kan te enige tyd gedurende kantoorure geïnspekteer word.

Geteken te Germiston hierdie 24ste dag van September 1987.

(Get) I. J. Greyling, vir Greylings, Eiser se Prokureurs, Volkskasgebou 301, Presidentstraat 88, Germiston. Tel. No.: 825-3714.

Saak 87/9915

IN DIE HOOGGEREGSHOF VAN SUID-AFRIKA

(Witwatersrandse Plaaslike Afdeling)

In die saak tussen **Eastern Province Bouvereniging**, Eiser, en **Pieter Bydel van Rooyen**, Eerste Verweerder, **Elizabeth Engela van Rooyen**, Tweede Verweerder

Ter uitwinning van 'n Vonnis van die Hooggeregshof van Suid-Afrika (Witwatersrandse Plaaslike Afdeling) in bogemelde saak, sal 'n verkoping sonder 'n reserweprys gebou word ten kantore van die Adjunk-Balju, te Germiston Volkskasgebou, Presidentstraat 88, Germiston op Donderdag die 5de dag van November 1987, om 10h00 van die ondervermelde eiendom van die Verweerder op die voorwaardes wat deur die Venduafslaer gelees sal word ten tye van die verkoping en welke Voorwaardes by die kantore van die Adjunk-Balju, Germiston voor die verkoping ter insae sal lê.

(Kort beskrywing van eiendom, ligging, straatnommer ens.):

Portion 84 (A Portion of Portion 3) of Lot 54 Klippoortjie Agricultural Lots, Du Pisansiestraat 10, Elsburg.

Die volgende inligting word verskaf insake verbeteringe, alhoewel geen waarborg in verband daarmee gegee kan word nie:

Sitkamer, Eetkamer, 3 Slaapkamers, 2 Badkamers, 2 Toilette, 1 Stortbad, kombuis en waskamer, 2 Motorhuise, 1 Bediendekamer en 1 Stortbad.

Terme: 10% (Tien persent) van die koopprys in kontant op die dag van die verkoping en ten opsigte van die balans betaalbaar teen registrasie van Transport moet 'n Bank- of Bougenootskap- of ander aanneembare waarborg binne 14 (veertien) dae vanaf datum van verkoping verskaf word.

Vendukoste betaalbaar op dag van verkoping, sal as volg bereken word: 5 % (Vyf persent) op die opbrengs van die verkoping tot 'n bedrag van R10 000,00 (Tien Duisend Rand) en daarna 2½ % (Twee en 'n half persent) tot 'n maksimum fooi van R5 000,00 (Vyf Duisend Rand). Minimum fooie R30,00 (Dertig Rand).

Datum: 21 September, 1987.

Stabin, Gross & Shull, Eiser se Prokureur, Lovedayhuis 801, Lovedaystraat 15, Posbus 3744, Johannesburg. Tel: 836-7091. Ref: P. Stabin/px.

Case 2696/87

IN THE MAGISTRATE'S COURT FOR THE DISTRICT OF KEMPTON PARK HELD AT KEMPTON PARK

In the matter between **Allied Building Society**, Plaintiff, and **A. M. du Plessis**, Defendant

In pursuance of the Judgment in the Court of the Magistrate, Kempton Park and a Warrant of Execution dated the 3rd August 1987 the property listed hereunder will be sold in execution on the 4th day of November 1987 at 10h00 in front of the Messenger's Court 10 Park Street Kempton Park to the highest bidder:

Certain: Portion 19 more fully described in Sectional Plan No. SS35/1982.

Situate at: 19 Wida Hof, Houtkapper Street Birchleigh Extension 9 Kempton Park.

Measuring: 151 Square Metres.

Consisting of: House and Outbuildings i.e. lounge, dining room, 3 bedrooms 2 bathrooms, 3 toilets, double garage, all under tiled roof.

Subject to: Certain servitudes and held under Sectional Title No. ST35/1982 dated the 4th December 1986.

The conditions of sale will be read out immediately prior to the sale and may be inspected at the offices of the Messenger of the Court, Kempton Park.

(Sgd) M. C. van Rensburg, for Van Rensburg, Schoon & Cronje, 101 Myrtle Court, 23 West Street, P.O. Box 755, Kempton Park. Tel: 970-1203.

Case 3221/87

IN THE MAGISTRATE'S COURT FOR THE DISTRICT OF KEMPTON PARK HELD AT KEMPTON PARK

In the matter between **Allied Building Society**, Plaintiff, and **P. Labuschagne**, Defendant

In pursuance of the Judgment in the Court of the Magistrate, Kempton Park and a Warrant of Execution dated the 26th August 1987 the property listed hereunder will be sold in execution on the 11th day of November 1987 at 10h00 in front of the Messenger's Court 10 Park Street Kempton Park to the highest bidder:

Certain: Erf 115 Kempton Park West Township, Registration Division I R Transvaal.

Situate at: 40 Bultoprit Street, Kempton Park West.

Measuring: 612 square metres.

Consisting of: House and Outbuildings i.e. lounge, diningroom, 3 bedrooms, 1 toilet, carport, corrugated iron roof, fenced.

Subject to: Certain servitudes and held under Deed of Transfer No. T. 55393/86, dated the 2/12/86.

The conditions of sale will be read out immediately prior to the sale and may be inspected at the offices of the Messenger of the Court, Kempton Park.

(Sgd) M. C. van Rensburg, for Van Rensburg, Schoon & Cronje, 101 Myrtle Court, 23 West Street, P.O. Box 755, Kempton Park. Tel: 970-1203.

IN THE SUPREME COURT OF SOUTH AFRICA
(Transvaal Provincial Division)

In the matter between **Chamberlain & Karlsson (Pty) Limited t/a White River Building Supplies (Pty) Ltd**, Plaintiff, and **J. J. Prinsloo**, Defendant
In pursuance of a judgment of the above Honourable Court dated 9th September 1986 the following will be sold in execution to the highest bidder on Friday 6th November 1987 at 10h00 at the main entrance to the Magistrate's Court, Barberton:

Erf 264 situate in the township Komatipoort, Registration Division J U Transvaal.

Measuring 2 855 square metres.

Held by Deed of Transfer No. T.63230/1980.

Known as 462 Bourhill Street, Komatipoort.

The property has been improved with a dwelling house and the normal outbuildings, although this is not guaranteed.

The conditions of sale and reserve price, (if any) will be read immediately before the sale and will in the meantime lie for inspection at the offices of the Deputy Sheriff, United Building, 35 President Street, Barberton.

Dated at Barberton on this the 30th day of September 1987.

C. J. Joubert, Asst Deputy Sheriff, Barberton, 35 President Street, Barberton, 1300. (Telephone No.: Code: 01314-24200/24202.)

Saak 22241/86

IN DIE HOOGGEREGSHOF VAN SUID-AFRIKA
(Transvaalse Provinsiale Afdeling)

In die saak tussen **Eerste Nasional Bank van Suidelike Afrika Beperk**, Eiser, en **Johannes Michael Richter**, Verweerder

Ingevolge 'n vonnis van die Hooggereshof van Suid-Afrika (Transvaalse Provinsiale Afdeling) en lasbrief gedateer 2 Maart 1987 in bogemelde saak, word 'n openbare veiling sonder 'n reserwe prys deur die adjunk-balju Koster voor die Landdroskantoor, Malanstraat, Koster, Transvaal gehou op Vrydag 6 November 1987 om 10h00 volgens voorwaardes wat nou by P H F Grobler, die adjunk-balju Koster, te Kosterfontein, Koster, Transvaal se kantoor (telefoonnommer 0142412 369) ter insae lê en wat ten tye van die veiling voorgelees sal word, van die volgende eiendom:

Sekere gedeelte 3 ('n gedeelte van gedeelte 1) van die plaas Panfontein 492, registrasie afdeling J.P., Transvaal.

Groot 1,7131 hektaar.

Geregistreer in die naam van die verweerder kragtens akte van transport T17595/85.

Geen waarborg omtrent die omvang en verbeterings op die eiendom word gegee nie.

Terme:

Tien per centum (10%) van die koopprys en afslaersgelde in kontant op die veilingsdag; die saldo teen oordrag wat verseker moet word deur 'n bank- of bougenootskapwaarborg wat binne veertien (14) dae van die veilingsdatum by die adjunk-balju ingelewer moet wees.

R. M. Brink, vir Rooth & Wessels, Prokureur vir Eiser, Barclays Bankgebou, Kerkplein, Pretoria. [Tel: (012) 3252940.]

KAAP • CAPE

Case 6439/87

IN THE MAGISTRATE'S COURT FOR THE DISTRICT OF CAPE TOWN HELD AT CAPE TOWN

In the matter between: **Boland Bank Limited**, Plaintiff, and **Eric Arthur Jackson**, Defendant

In pursuance of a Judgment of the above Court dated 10th April 1987, and an attachment in execution pursuant thereto, the following properties listed will be sold in front of the New Law Courts, Main Street, Port Elizabeth, by public auction on Friday, the 30th October 1987 at 14h15:

1. Section No. 10, Rollnick Court.

Measuring 115 (One hundred and fifteen) square metres;

2. Section No. 30, Rollnick Court.

Measuring 16 (Sixteen) square metres.

The full Conditions of Sale will be read immediately prior to the sale and may be inspected at the office of the Messenger of the Court, Port Elizabeth South.

Terms: 10% in Cash on the date of sale and the balance against transfer.

Dated at Port Elizabeth this 28th day of August 1987.

Burman Katz Saks & Butler, Plaintiff's Attorneys, Security Place, cnr. Market and Hancock Streets, Port Elizabeth (Ref. Mr. Saks/jg).

Case 2226/87

IN THE MAGISTRATE'S COURT FOR THE DISTRICT OF KUILS RIVER HELD AT KUILS RIVER

In the matter between: **South African Permanent Building Society**, Plaintiff, and **Patrick Jonathan Williams**, and **Anna Christina Williams**, Defendants

In the above matter a sale will be held on Wednesday 28 October 1987 at 12,15 pm at the site of No. 28 Lacus Street, Eerste River being:

Erf 146 Kleinvlei situate in Melton Rose Local Area, Administrative District of Stellenbosch.

Measuring: 479 m².

Conditions of Sale

1. The sale is subject to the terms and conditions of the Magistrate's Court Act No. 32 of 1944, the property being sold voetstoots and as it stands and subject to the conditions of the existing Title Deed.

2. One-tenth of the purchase price shall be paid immediately after the property is declared to be sold and the balance of the purchase price together with interest thereon at the rate of (16,5%) Sixteen Comma Five Per Centum per annum is to be paid against registration of transfer, which shall be given and taken forthwith after the sale.

3. This property is reserved for the use of members of the Coloured Group.
 4. The following improvements are on the property A single storey brick dwelling under tiled roof comprising of five rooms, 1½ bathroom, kitchen and w.c. (although nothing in this respect is guaranteed).
 5. The complete Conditions of Sale will be read out at the time of the sale and may be inspected prior thereto at the offices of the Messenger of the Court, Kuils River and at the offices of the undersigned.
- Minde Schapiro & Smith, Attorneys for Plaintiff, 49 Durban Road, Bellville.

Case 13126/87

IN THE MAGISTRATE'S COURT FOR THE DISTRICT OF BELLVILLE HELD AT BELLVILLE

In the matter between: **South African Permanent Building Society**, Plaintiff, and **Hendrik Johannes Nicolaas Shepherd**, and **Christina Elizabeth Shepherd**, Defendants

In the above matter a sale will be held on Friday 30 October 1987 at 12,15 pm at the site of No. 65 Visagie Street, Parow Valley being: Erf 10082 Parow situate in the Municipality of Parow, Division of the Cape.

Measuring: 494 m².

Conditions of Sale

1. The sale is subject to the terms and conditions of the Magistrate's Court Act No. 32 of 1944, the property being sold voetstoots and as it stands and subject to the conditions of the existing Title Deed.
2. One-tenth of the purchase price shall be paid immediately after the property is declared to be sold and the balance of the purchase price together with interest thereon at the rate of (16,5%) Sixteen Comma Five Per Centum per annum is to be paid against registration of transfer, which shall be given and taken forthwith after the sale.
3. This property is reserved for the use of members of the White Group.
4. The following improvements are on the property A single storey brick dwelling under a tiled roof comprising of lounge, two bedrooms, kitchen, bathroom and single garage (although nothing in this respect is guaranteed).
5. The complete Conditions of Sale will be read out at the time of the sale and may be inspected prior thereto at the offices of the Messenger of the Court, Bellville and at the offices of the undersigned.

Minde Schapiro & Smith, Attorneys for Plaintiff, 49 Durban Road, Bellville.

Case 9347/87

IN THE MAGISTRATE'S COURT FOR THE DISTRICT OF BELLVILLE HELD AT BELLVILLE

In the matter between: **South African Permanent Building Society**, Plaintiff, and **Keith John Norval**, Defendant

In the above matter a sale will be held on Friday 29 October 1987 at 11,45 am at the site of No. 7 Piet Retief Street, Parow Valley being:

1. Erf 19198 Parow situate in the Municipality of Parow, Division of the Cape,

Measuring: 446 m².

2. Erf 19199, Parow, situate as above,

Measuring: 446 m².

Conditions of Sale

1. The sale is subject to the terms and conditions of the Magistrate's Court Act No. 32 of 1944, the property being sold voetstoots and as it stands and subject to the conditions of the existing Title Deed.
2. One-tenth of the purchase price shall be paid immediately after the property is declared to be sold and the balance of the purchase price together with interest thereon at the rate of (16,5%) Sixteen Comma Five Per Centum per annum is to be paid against registration of transfer, which shall be given and taken forthwith after the sale.
3. This property is reserved for the use of members of the White Group.
4. The following improvements are on the property A single storey brick dwelling under a tiled roof comprising of five rooms, bathroom, kitchen and single garage (although nothing in this respect is guaranteed).
5. The complete Conditions of Sale will be read out at the time of the sale and may be inspected prior thereto at the offices of the Messenger of the Court, Bellville and at the offices of the undersigned.

Minde Schapiro & Smith, Attorneys for Plaintiff, 49 Durban Road, Bellville.

Case 2840/87

IN THE MAGISTRATE'S COURT FOR THE DISTRICT OF BELLVILLE HELD AT BELLVILLE

In the matter between: **South African Permanent Building Society**, Plaintiff, and **Ronald John Payten**, and **Leigh Rebecca Payten**, Defendants

In the above matter a sale will be held on Wednesday 28 October 1987 at 11,15 am at the site of No. 1 Joubert Street, Kraaifontein being:

Erf 237 Kraaifontein situate in the Municipality of Kraaifontein, Division of Paarl.

Measuring: 719 m².

Conditions of Sale

1. The sale is subject to the terms and conditions of the Magistrate's Court Act No. 32 of 1944, the property being sold voetstoots and as it stands and subject to the conditions of the existing Title Deed.
2. One-tenth of the purchase price shall be paid immediately after the property is declared to be sold and the balance of the purchase price together with interest thereon at the rate of (16,5%) Sixteen Comma Five Per Centum per annum is to be paid against registration of transfer, which shall be given and taken forthwith after the sale.
3. This property is reserved for the use of members of the White Group.

4. The following improvements are on the property A single storey brick dwelling under an asbestos roof comprising of five rooms, kitchen, bathroom, w.c. and single garage (although nothing in this respect is guaranteed).

5. The complete Conditions of Sale will be read out at the time of the sale and may be inspected prior thereto at the offices of the Messenger of the Court, Bellville and at the offices of the undersigned.

Minde Schapiro & Smith, Attorneys for Plaintiff, 49 Durban Road, Bellville.

Case 4649/87

IN THE MAGISTRATE'S COURT FOR THE DISTRICT OF KUILS RIVER HELD AT KUILS RIVER

In the matter between: **South African Permanent Building Society**, Plaintiff, and **Kendan Ontwikkelings (Proprietary) Limited**, Defendant

In the above matter a sale will be held on Thursday 29 October 1987 at 10h00 am at the site, remainder Erf 191, Brackenfell, measuring 3,2055 hectares, situate on Ravlee, Els and Lotz Streets, Brackenfell.

Conditions of Sale

1. The sale is subject to the terms and conditions of the Magistrate's Court Act No. 32 of 1944, the property being sold voetstoots and as it stands and subject to the conditions of the existing Title Deed.

2. One-tenth of the purchase price shall be paid immediately after the property is declared to be sold and the balance of the purchase price together with interest thereon at the rate of (16,5%) Sixteen Comma Five Per Centum per annum is to be paid against registration of transfer, which shall be given and taken forthwith after the sale.

3. This property is reserved for the use of members of the White Group.

4. The following improvements are on the property: Vacant erf (although nothing in this respect is guaranteed).

5. The complete Conditions of Sale will be read out at the time of the sale and may be inspected prior thereto at the offices of the Messenger of the Court, Kuils River and at the offices of the undersigned.

Minde Schapiro & Smith, Attorneys for Plaintiff, 49 Durban Road, Bellville.

Saak 24498/86

IN DIE LANDDROSHOF VIR DIE DISTRIK VAN BELLVILLE GEHOU TE BELLVILLE

In die saak tussen: **Allied Bouvereniging Beperk**, Eiser, en **G. C. S. Smith**, Verweerder

Kragtens 'n uitspraak van bogemelde Agbare Hof en Lasbrief tot Eksekusie, sal die ondervermelde onroerende eiendom per Openbare Veiling verkoop word op Woensdag, 4 November 1987 om 10h00 op die perseel geleë te Visserstraat 83, Kraaifontein;

Die onroerende eiendom te koop, staan bekend as:

Erf 7778, Kraaifontein, geleë in die Munisipaliteit van Kraaifontein, afdeling Paarl;

Groot 496 Vierkante Meter;

Gehou kragtens Akte van Transport No. T8327/1979, synde 'n woonhuis bestaande uit baksteenmure met asbesdak, drie slaapkamers, kombuis, badkamer/toilet, eetkamer, sitkamer, enkel motorhuis.

Verkoopsvoorwaardes

1. Die verkoping sal voetstoots geskied, onderworpe aan die bepalings van die Wet op Landdroshowe, No. 32 van 1944, soos gewysig, asook die voorwaardes van die titelakte waaronder die eiendom gehou word.

2. Een Tiende (1/10) van die koopprijs moet by wyse van kontant of bankgewaarborgde tjek betaal word onmiddellik nadat die eiendom verkoop verklaar is, terwyl die balans van die koopprijs tesame met rente daarop teen 15% per jaar vanaf datum van verkoping tot datum van registrasie van oordrag, in kontant betaal moet word teen registrasie van oordrag. Die koper moet voorts binne veertien (14) dae na die verkoping, Vonnisskuldeiser voorsien van 'n bank- of bouverenigingswaarborg vir behoorlike nakoming van al sy verpligtinge onder die verkoopsvoorwaardes.

3. Aandag word gevestig op die bepalings van die Wet op Groepsgebiede, No. 36 an 1966 en die Wet op Gemeenskapsontwikkeling, No. 3 van 1966, soos gewysig, waarkragtens eiendomsreg ten opsigte van gemelde eiendom beperk word tot lede van die Blanke Groep.

4. Die verkoping sal voorts onderworpe wees aan verdere voorwaardes wat ten tye van die verkoping uitgelees sal word, welke verdere voorwaardes ter insae lê by die kantoor van die afslaer, Herman Smit, Smit Nel Kruger & Potgieter, Stasieweg 9, Kraaifontein.

Geteken te Kraaifontein op hierdie 14de dag van September 1987.

J. T. Potgieter, vir Smit Nel Kruger & Potgieter, Stasieweg 9, Kraaifontein.

Saak 23073/86

IN DIE LANDDROSHOF VIR DIE DISTRIK VAN BELLVILLE GEHOU TE BELLVILLE

In die saak tussen: **Kraaifontein Munisipaliteit**, Eiser, en **C. P. C. du Plessis**, Verweerder

Kragtens 'n uitspraak van bogemelde Agbare Hof en Lasbrief tot Eksekusie, sal die ondervermelde onroerende eiendom per Openbare Veiling verkoop word op Dinsdag, 3 November 1987 om 10h00 op die perseel geleë te Edwardstraat 111, Kraaifontein;

Die onroerende eiendom te koop, staan bekend as:

Erf 6641, Kraaifontein, geleë in die Munisipaliteit van Kraaifontein, Afdeling Paarl;

Groot 744 Vierkante Meter;

Gehou kragtens Akte van Transport No. T 40392/1974, synde 'n woonhuis bestaande uit baksteengebou met asbesdak, sitkamer/eetkamer, kombuis, badkamer, 3 slaapkamers, toilet.

Verkoopsvoorwaardes

1. Die verkoping sal voetstoots geskied, onderworpe aan die bepalings van die Wet op Landdroshowe, No. 32 van 1944, soos gewysig, asook die voorwaardes van die titelakte waaronder die eiendom gehou word.

2. Een Tiende (1/10) van die koopprijs moet by wyse van kontant of bankgewaarborgde tjek betaal word onmiddellik nadat die eiendom verkoop verklaar is, terwyl die balans van die koopprijs tesame met rente daarop teen 15% per jaar vanaf datum van verkoping tot datum van registrasie van oordrag, in kontant betaal moet word teen registrasie van oordrag. Die koper moet voorts binne veertien (14) dae na die verkoping, Vonnisskuldeiser voorsien van 'n bank- of bouverenigingswaarborg vir behoorlike nakoming van al sy verpligtinge onder die verkoopsvoorwaardes.

3. Aandag word gevestig op die bepalings van die Wet op Groepsgebiede, No. 36 an 1966 en die Wet op Gemeenskapsontwikkeling, No. 3 van 1966, soos gewysig, waarkragtens eiendomsreg ten opsigte van gemelde eiendom beperk word tot lede van die Blanke Groep.

4. Die verkoping sal voorts onderworpe wees aan verdere voorwaardes wat ten tye van die verkoping uitgelees sal word, welke verdere voorwaardes ter insae lê by die kantoor van die afslaer, Herman Smit, Smit Nel Kruger & Potgieter, Stasieweg 9, Kraaifontein.

Geteken te Kraaifontein op hierdie 15de dag van September 1987.

J. T. Potgieter, vir Smit Nel Kruger & Potgieter, Stasieweg 9, Kraaifontein.

Case 2174/87

IN THE SUPREME COURT OF SOUTH AFRICA
(South-Eastern Cape Local Division)

In the matter between: **South African Permanent Building Society**, Plaintiff, and **Luthando Dennis Matthews**, Defendant

In pursuance of a Judgment of the above Court, dated the 23rd day of September, 1987 and an attachment in execution, the right of leasehold to the following immovable property will be sold from the basement of the A.A. Mutual Building, 15 Rink Street, Central, Port Elizabeth, by public auction on Friday, the 6th November, 1987 at 2.15 p.m.

Site 36523 Zwide IV Stage IA, Measuring 227 Square Metres.

Situate At 8 Hewana Street, Zwide, Port Elizabeth.

While nothing is guaranteed, it is understood that on the property is a detached space frame dwelling under a tiled roof, consisting of four rooms, kitchen and one and a half bathroom.

A substantial Building Society bond can be arranged for an approved purchaser.

The Conditions of Sale will be read prior to the sale and may be inspected at the Deputy Sheriff's Office, 5th Floor, A.A. Mutual Building, 15 Rink Street, Port Elizabeth.

Terms: 10%, and Deputy Sheriff's charges of 5% on the first R10 000,00 and 2,5% on the balance, on the date of sale, the balance against transfer to be secured by a Bank or Building Society guarantee, to be approved of by Plaintiff's Attorneys, to be furnished to the Deputy Sheriff within Twenty One (21) days from the date of the sale.

Dated at Port Elizabeth this 28th day of September, 1987.

Pagdens, Plaintiff's Attorneys, Nedbank Centre, 88 Main Street, Port Elizabeth.

Case 16453/87

IN THE MAGISTRATE'S COURT FOR THE DISTRICT OF PORT ELIZABETH HELD AT TODD CHAMBERS, TODD STREET,
PORT ELIZABETH

In the matter between: **Allied Building Society**, Plaintiff, and **Charl Wynand Louw Baard**, Defendant

In pursuance to a Judgment in the Court of the Magistrate of the District of Port Elizabeth dated the 1st August 1987 the property listed hereunder will be sold in execution on Friday 30th October 1987 at 14h15 at the front entrance of the Law Courts, North End, Port Elizabeth, to the highest bidder and for cash:

Erf: 860 Newton Park in the Municipality and Division of Port Elizabeth,

Measuring: 697 square metres.

Situated At: 15 Glen Hurd Drive, Glen Hurd, Port Elizabeth.

Conditions of Sale:

The purchase price will be payable as to a deposit in cash of 10% and the balance against transfer. The full conditions of sale will be read immediately prior to the sale and may be inspected at the office of the Messenger of the Court, Port Elizabeth. A substantial Building Society loan can be arranged for an approved purchaser.

Dated at Port Elizabeth on the 17th day of September 1987.

J. G. Richards, for Rushmere Noach & Partners, Plaintiff's attorneys, Allied Building, Port Elizabeth, Ref: Mr Richards/cn. Tel:(041)523450.

Case 17431/87

IN THE MAGISTRATE'S COURT FOR THE DISTRICT OF PORT ELIZABETH HELD AT TODD CHAMBERS, TODD STREET,
PORT ELIZABETH

In the matter between: **Allied Building Society**, Plaintiff, and **Edwin Petrus Johannes Walt**, Defendant

In pursuance to a Judgment in the Court of the Magistrate of the District of Port Elizabeth dated the 20th August 1987 the property listed hereunder will be sold in execution on Friday 30th October 1987 at 14h15 at the front entrance of the Law Courts, North End, Port Elizabeth, to the highest bidder and for cash:

Erf: 782 Algoa Park in the Municipality and Division of Port Elizabeth,

Measuring: 599 (Five Hundred and Ninety Nine) square metres.

Situated At: 2 Keurboom Crescent, Algoa Park, Port Elizabeth.

Conditions of Sale:

The purchase price will be payable as to a deposit in cash of 10% and the balance against transfer. The full conditions of sale will be read immediately prior to the sale and may be inspected at the office of the Messenger of the Court, Port Elizabeth. A substantial Building Society loan can be arranged for an approved purchaser.

Dated at Port Elizabeth on the 14th day of September 1987.

J. G. Richards, for Rushmere Noach & Partners, Plaintiff's attorneys, Allied Building, Port Elizabeth, Ref: Mr Richards/cn. Tel:(041)523450.

IN DIE LANDDROSHOF VIR DIE DISTRIK VAN WORCESTER GEHOU TE WORCESTER

In die saak tussen: **Die Suid Afrikaanse Permanente Bouverenging**, Eiser, en **Mnr. N. J. M. van West**, Verweerder

Ingevolge uitspraak van bogenoemde Agbare Hof en die Lasbrief vir Eksekusie gedateer 17 Junie 1987 sal die hieronder vermelde eiendom verkoop word op die 4de dag van November 1987 om 11h00 voormiddag op die perseel aan die persoon wie die hoogste aanbod maak, naamlik:

Erf No. 6295 Worcester.

Afdeling Worcester.

Groot 334 vierkante meter.

Gehou kragtens Akte van Transport No. 32575.

Bekend As Swartstraat 44, Worcester.

Die volgende verbeterings is op die eiendom geleë maar in hierdie verband word niks gewaarborg nie, naamlik: Losstaande enkel verdieping woonhuis, 4 slaapkamers, 1 sitkamer, 1 badkamer, buitemure het baksteen konstruksie, volvloermatte en klip, Rhino plafon, Asbes dak, buite toilet en draad omheining.

Die verkoopsvoorwaardes wat onmiddellik voor die verkoping gelees sal word, lê ter insae in die kantoor van die Geregsbode, Worcester en by die ondergetekendes.

Die belangrikste voorwaarde daarin vervat is die volgende: Dat die eiendom vir kontant aan die hoogste bieder verkoop sal word.

Geteken te Worcester op hierdie 7de dag van September 1987.

Robertson Botha Kotzé en Badenhorst, Kerkstraat 66, Posbus 18, Worcester, 6850.

Saak 509/87

IN DIE LANDDROSHOF VIR DIE DISTRIK VAN BREDASDORP GEHOU TE BREDASDORP

In die saak tussen: **Die Suid Afrikaanse Permanente Bouverenging**, Eiser, en **Mnr. G. W. L. Walters**, Verweerder

Ingevolge uitspraak van bogenoemde Agbare Hof en die Lasbrief vir Eksekusie gedateer 26 Junie 1987 sal die hieronder vermelde eiendom verkoop word op die 6de dag van November 1987 om 11h00 voormiddag op die perseel aan die persoon wie die hoogste aanbod maak, naamlik:

Gedeelte 26 ('n gedeelte van Gedeelte 7) van die Plaas Wolven Gat No. 297.

Afdeling Bredasdorp.

Groot 1,5116 (een komma vyf een ses) hektaar.

Gehou kragtens Akte van Transport No. T49800/84.

Bekend As Plaas Wolvengat 297, Bredasdorp.

Die volgende verbeterings is op die eiendom geleë maar in hierdie verband word niks gewaarborg nie, naamlik—Kleinhoewe met enkel verdieping woning met een badkamer, buitemure het baksteen konstruksie, met plank en Parket vloere, hout plafonne, sinkdak, buite stoorkamer, gas warmwater sisteem, 2 kragopwekkers voorsien 220V en 32V, 3 boorgate lewer plus minus 1,000 l.p.h., omheining.

Die verkoopsvoorwaardes wat onmiddellik voor die verkoping gelees sal word, lê ter insae in die kantoor van die Geregsbode, Bredasdorp en by die ondergetekendes.

Die belangrikste voorwaarde daarin vervat is die volgende: Dat die eiendom vir kontant aan die hoogste bieder verkoop sal word.

Geteken te Worcester op hierdie 7de dag van September 1987.

Robertson Botha Kotzé en Badenhorst, Kerkstraat 66, Posbus 18, Worcester, 6850.

Case 25351/85

IN THE MAGISTRATE'S COURT FOR THE DISTRICT OF WYNBERG HELD AT WYNBERG

In the matter between: **Cape of Good Hope Bank Limited formerly The Cape of Good Hope Savings Bank**, Plaintiff, and **H. J. du Plessis**, Defendant

In execution of the Judgment of the Magistrate's Court of Wynberg in the above matter, a sale will be held on Thursday the 29th day of October 1987 at 10h00 of the following immovable property:

Erf: 14900 Cape Town at 76 Chamberlain Street, Woodstock, in the Municipality of Cape Town Cape Division.

In extent: 169 (One Hundred and Sixty Nine) square metres.

Held by: Deed of Transfer No.: T.7974/1987.

Also known as: 76 Chamberlain Street, Woodstock.

Conditions of Sale

1. The sale is subject to the terms and conditions of the Magistrate's Court Act No. 32 of 1944 the property being sold voetstoots and as it stands and subject to the conditions of the existing title deed. The highest bidder shall be the purchaser, subject to the provisions of the Section 66 of the above Act.

2. One-tenth (1/10th) of the purchase price shall be paid in cash or by means of a bank marked cheque and immediately after the property is declared to be sold and the balance of the purchase price together with interest thereon at the rate to be paid against registration of transfer, and received within fourteen (14) days after the date of sale by a bank or building society guarantee.

3. Attention is drawn to the provisions of the Group Areas Act No. 36 of 1966, as amended, and also the Community Development Act No. 3 of 1966, as amended, and the onus shall be on the purchaser to acquire the property, within fourteen (14) days of the date of sale.

And subject to further conditions which will be read out at the time of the sale and which may be inspected at the offices of the Messenger of the Court at Maurcon House, 1st Floor, Barrack Street, Cape Town.

Dated at Cape Town this 10th day of September 1987.

G. I. Rushton, for Findlay & Tait Inc., Plaintiff's attorneys, 30 Hout Street, Cape Town.

To: The Messenger of the Court, Magistrate's Court, Wynberg.

IN DIE LANDDROSHOF VIR DIE DISTRIK GOODWOOD GEHOU TE GOODWOOD

In die saak tussen: **Die Trust Bank van Afrika Beperk**, Eiser, en **J. E. du Toit**, Eerste Verweerder en **F. J. Snyman**, Tweede Verweerder (Eiendom wat te koop aangebied word)

Ingevolge 'n Vonnis van die Landdroshof Goodwood gedateer 9 April 1986 en 'n Lasbrief vir Eksekusie word die eiendom van die tweede verweerder hieronder beskryf op die perseel te Richmondstraat 63, Vrijzee, per geregtelike veiling te koop aangebied op Woensdag, 18 November 1987 om 12h00.

Seker stuk grond geleë in die Munisipaliteit van Goodwood, Afdeling van die Kaap, synde Erf 5750, Goodwood;

Groot: 495 (Vierhonderd Vyf en Negentig) Vierkante Meter;

Gehou kragtens Transportakte No. T18270 van 1980.

Voorwaardes:

1. Die eiendom word voetstoots verkoop aan die hoogste bieër kragtens die Wet op Landdroshowe, No. 32 van 1944, en die reëls daaronder uitgevaardig.

2. Tien persent (10%) van die koopsom moet betaal word in kontant of deur middel van 'n bankgewaarborgde tjek onmiddellik nadat verklaar is dat die eiendom verkoop is. Die balans van die koopsom tesame met rente daarop bereken teen 15% per jaar maandeliks saamgestel te word vanaf 18 November 1987 moet betaal word teen registrasie van transport. 'n Bank of bougenootskapswaarborg vir betaling van die balans en rente moet aan die Geregsbode oorhandig word binne veertien dae na datum van die veiling.

3. Die Koper sal verantwoordelik wees vir afslaerskoste, advertensiekoste, koste van registrasie van transport, alle agterstallige belastings en gelde, indien enige, en alle ander koste wat nodig is om die gee van oordrag moontlik te maak.

4. Besit sal onderworpe wees aan bestaande huurkontrakte, indien enige, en sal gegee word op datum van die veiling. Die aandag word gevestig op die bepalinge van die Wet op Groepsgebiede, No. 36 van 1966, asook die Wet op Gemeenskapsontwikkeling, No. 3 van 1966, en die Koper moet die nodige bewys of permit verkry wat hom magtig om die eiendom te besit binne veertien dae na die veiling. Die eiendom is geleë binne 'n geproklameerde Blanke Groepsgebied.

En Verder onderworpe aan die volledige veilingsvoorwaardes wat uitgelees sal word ten tye van die veiling en wat ter insae lê by die kantoor van die Geregsbode te Goodwood en by die kantoor van die ondergemelde Bill Tolken Bresler & Brynard, Prokureurs vir Eiser, Sarel Cilliersstraat 1, Bellville.

Bill Tolken Bresler & Brynard, Sarel Cilliersstraat 1 (Posbus 687, Sanlamhof 7532), Bellville. Datum en verwysing: 28 September 1987, Mev. M. Bothma.

Saak 145/87

IN DIE LANDDROSHOF VIR DIE DISTRIK VAN DE AAR GEHOU TE DE AAR

In die saak tussen: **S A Permanente Bouvereniging**, Eiser, en **A. R. Breytenbach**, Verweerder

Ter uitvoering van 'n vonnis van die Landdros te De Aar en 'n Lasbrief gedateer 16 Julie 1987 sal die ondervermelde eiendom in Eksekusie verkoop word op 30 Oktober 1987 om 10h00 voor die Landdroskantoor De Aar.

Erf 667 De Aar geleë in die Munisipaliteit De Aar Afdeling Philipstown.

Groot: 684 (Ses Honderd Vier en Tagtig) vierkante meter.

Voorwaardes van Verkoop:

Die eiendom word verkoop aan die hoogste bieder onderhewig aan die voorwaardes van die Landdroshowewet en die reëls daaronder gemaak en onderhewig aan die voorwaardes van die transportakte is soverre dié van toepassing is.

Terme:

Die Koopprijs sal in kontant betaal word by registrasie van transport of andersins, soos die afslaer of bode mag reël. Die koopprijs moet gewaarborg word deur goedgekeurde bank- of bougenootskapswaarborg gelewer te word op aanvraag van die Eiser.

Voorwaardes:

Die volle voorwaardes van verkoop, gelees te word deur die afslaer onmiddellik voor die verkoping, is ter insae by die Geregsbode, De Aar.

André Venter, Prokureur vir Eiser, Voortrekkerstraat 47 (Posbus 22), Boland Bank Gebou, De Aar.

Saak 217/87

IN DIE LANDDROSHOF VIR DIE DISTRIK VAN SWELLENDAM GEHOU TE SWELLENDAM

In die saak tussen: **Suid-Afrikaanse Permanente Bouvereniging**, Vonnisskuldeiser, en **A. P. Saayman**, en **J. Saayman**, Vonnisskuldenaars

'n Veiling in bovermelde saak gehou op Vrydag 30 Oktober 1987 om 10h00 te Akasialaan 32 Swellendam synde Erf 2385 ('n gedeelte van Erf 2022) Swellendam, in die Munisipaliteit en Afdeling Swellendam, Groot 504 Vierkante Meter.

Veilingsvoorwaardes:

1. Die veiling is onderworpe aan die bepalinge en voorwaardes van die Wet op Landdroshowe No. 32 van 1944 en ook onderworpe aan die bepalinge van die Wet op Groepsgebiede No. 36 van 1966, soos gewysig en die Wet op Gemeenskapsontwikkeling No. 3 van 1966 soos gewysig. Die eiendom word "Voetstoots" en onderworpe aan die voorwaardes van die bestaande Titelbewys verkoop.

2. Een-Tiende van die koopprijs sal kontant betaal word onmiddellik nadat die eiendom verkoop verklaar word en die saldo van die koopprijs, met rente daarop teen die koers van 17% per jaar sal teen registrasie van transport betaal word, wat onverwyld nà die veiling gegee en geneem sal word.

3. Die volgende verbeteringe is op die eiendom—enkelwoning met vyf woonvertrekke, een badkamer, kombuis, motorhuis en pakkamer onder asbesdak.

4. Die volledige veilingsvoorwaardes sal tydens die veiling voorgelees word en is beskikbaar in die kantoor van die Geregsbode, Swellendam en in die kantoor van die ondergetekende.

Mnre Sandler Smith & Kie., Prokureurs vir Vonnisskuldeiser, Badstraat 42A, Posbus 40, Montagu, 6720, Telefoon: 0234-41107.

IN THE MAGISTRATE'S COURT FOR THE DISTRICT OF SIMON'S TOWN HELD AT SIMON'S TOWN

In the matter between: **Allied Building Society**, Plaintiff, and **Mr. Abdulla A. J. Moses**, Defendant

In Terms of a Judgment granted by the Magistrate's Court for the District of Simon's Town dated the 1st day of April 1987 and a Warrant of Execution dated the 13th April 1987, the undermentioned property will be sold voetstoots and without reserve in execution by Public Auction held on the premises, to the highest bidder on Wednesday 28th October 1987 at 12h00 noon.

Erf 91 Ocean View situate in the Local Area of Ocean View, Cape Division.

In Extent: 562 (five hundred and sixty two) square metres.

Address: 28 Aries Avenue, Ocean View, Fish Hoek.

Conditions of Sale

1. The property will be sold in execution without reserve and voetstoots to the highest bidder by Public Auction and subject to the provisions and conditions of the Magistrate's Court Act No. 32 of 1944 as amended and the Rules applicable thereto and also the servitudes and conditions attached to the property contained in the relevant Title Deeds.

2. The following information is furnished but not guaranteed: Single dwelling.

3. The full and complete conditions of sale will be announced by the Auctioneers, Messrs. S. M. Sass & Company of 203 Avlew Place, Claremont, immediately before the sale and will lie for inspection at the offices of the Messenger of the Court and at the offices of the Auctioneers.

4. Payment shall be effected as follows:

Ten Per Cent (10%) of the purchase price on the day of the sale and the balance together with interest thereon at the rate of 16% (Sixteen per cent) per annum from the date of sale to date of registration of transfer against transfer of the property into the name of the purchaser, which payment shall be secured by an approved Bank or Building Society guarantee within Fourteen (14) days of the date of sale.

Dated at Claremont this 16th day of September 1987.

W. D. Baxter, for Buchanan Boyes & Klossers, Townhouse Chambers, Mosque Lane, Claremont.

Case 18982/86

IN THE MAGISTRATE'S COURT FOR THE DISTRICT OF BELLVILLE HELD AT BELLVILLE

In the matter between: **Maitland Timber Co. (Pty) Limited**, Plaintiff, and **Mr. A. J. Britz**, Defendant

In pursuance of a Judgment of the above Honourable Court obtained on the 29th January 1987 and a Warrant of Execution, the undermentioned property will be sold in Execution without reserve by the Messenger of the Court, Bellville on the 11th day of November 1987 at 10.00 a.m. at the premises—11 Tulip Street, Amanda Glen, Durbanville, to the highest bidder.

Certain Erf 2219 Eversdale, in the Municipality of Durbanville, Cape Division;

Measuring 1029 Square Metres;

Held By Deed of Transfer T.2846/1986.

Terms and Conditions of Sale

The Sale will be subject to payment of 10% of the Purchase price on the date of the sale, the balance to be secured by a Bank or Building Society Guarantee cheque within 14 days on the date of sale.

The full conditions of sale may be inspected at the offices of the Messenger of the Court, Bellville.

The following improvements are reported, but nothing is guaranteed: A vacant plot.

Signed and Dated at Cape Town on this the 16th September 1987.

Asherson and Asherson, Plaintiff's Attorneys, 34 Plein Street, Cape Town, Tel: 466240, Ref: Miss. Badria/coll.

Case 20806/85

IN THE MAGISTRATE'S COURT FOR THE DISTRICT OF WYNBERG HELD AT WYNBERG

In the matter between: **Barclays Western Bank Limited**, Plaintiff, and **Jacob Rudolph Fransman**, Defendant

In execution of the Judgment of the Magistrate's Court at Wynberg, in the above matter, a sale will be held on Tuesday, the 1st day of December, 1987 at 10.00 a.m. on the spot, of the following immovable property:

Erf 82660 Cape Town in the Municipality of Cape Town, Cape Division.

Measuring: 543 (Five Hundred and Forty Three) Square Metres.

The above property is situate and known as "Mazeltov", Allenby Drive, Steenberg, and comprises: One single dwelling with brick walls under a tiled roof, consisting of a kitchen, a lounge, three bedrooms, one bathroom and one toilet.

Conditions of Sale

1. The sale is subject to the terms and conditions of the Magistrate's Court Act No. 32 of 1944 (as amended), the property being sold voetstoots and as it stands and subject to the conditions of the existing Title Deed. The highest bidder shall be the Purchaser, subject to the provisions of the Section 66 of the above Act.

2. One-tenth (1/10th) of the purchase price shall be paid in cash or by means of a bank-marked cheque and immediately after the property is declared to be sold and the balance of the purchase price together with interest thereon at the ruling Building Society rate to be paid against registration of transfer, and secured within fourteen (14) days after the date of sale by a Bank or Building Society guarantee.

3. Attention is drawn to the provisions of the Group Areas Act No. 36 of 1966, and also Act No. 3 of 1966. The property is situate within a proclaimed Coloured Group Area.

And subject to further conditions which will be read out at the time of the sale and which may be inspected at the offices of the Messenger of the Court, Wynberg.

Kantor & Fialkov, Attorneys for Judgment Creditor, 120, Main Road, Claremont.

IN THE MAGISTRATE'S COURT FOR THE DISTRICT OF WYNBERG HELD AT WYNBERG

In the matter between: **The South African Permanent Building Society**, Judgment Creditor, and **Manuel Cileu Rebelo**, Judgment Debtor

In Execution of the Judgment of the Magistrate's Court of Wynberg in the above matter, on the 30 October 1987 at 2 p.m. at 7 Waterloo Road, Kenwyn, 7764, a sale of the following immovable property, situate at the said address, namely:

Erf 63038 Cape Town at Lansdowne, situate in the Municipality of Cape Town, Division of the Cape.

In Extent: 620 square metres.

The property includes a dwelling comprising: Brick walls under asbestos roof, consisting of: 1 Lounge, 1 Kitchen, 3 Bedrooms, 1 Bathroom, 1 Toilet and 1 Garage.

Conditions of Sale

1. The sale is subject to the terms and conditions of the Magistrate's Court Act No. 32 of 1944 (as amended), the property being sold "voetstoots" and as it stands and subject to the conditions of the existing Title Deed. The highest bidder shall be the Purchaser, subject to the provisions of the Section 66 of the above Act.

2. One tenth (1/10th) of the purchase price shall be paid in cash or by means of a bank-marked cheque and immediately after the property is declared to be sold and the balance of the purchase price, together with interest thereon at the ruling Building Society rate to be paid against registration of transfer, and secured within fourteen (14) days after the date of sale by a Bank or Building Society guarantee.

3. Attention is drawn to the provisions of the Group Areas Act No. 36 of 1966, and also Act No. 3 of 1966. The property is situate within a proclaimed White Group Area.

And subject to further conditions which will be read out at the time of the sale and which may be inspected at the offices of the Messenger of the Court, Wynberg and at the offices of the Auctioneer's, Messrs. Ford & Van Niekerk, 156 Main Road, Plumstead.

Pincus Matz-Marquard Hugo-Hamman, Attorneys for Judgment Creditor, 135 Main Road, Claremont (Ref: A. F. Watermeyer).

Case 12968/86

IN THE MAGISTRATE'S COURT FOR THE DISTRICT OF WYNBERG HELD AT WYNBERG

In the matter between: **The Municipality of the City of Cape Town**, Plaintiff (Judgment Creditor), and **Mohammed Cassiem Sunday**, Defendant (Judgment Debtor)

In pursuance of a judgment in the Court of the Magistrate for the district of Wynberg dated 16th October 1986 and Writ of Execution dated 10th July 1987 the following will be sold in execution at 12h00 on the 11th November 1987 at the site being:

Certain Land situate at Athlone in the City of Cape Town, Cape Division, known as Erf 39835 Cape Town at Athlone.

Measuring 1876 (One Thousand Eight Hundred and Seventy-Six) square metres:

Held under Deed of Transfer No. 3136 dated 29th January 1985.

Also Known As 9 Charrick Crescent, Athlone.

Conditions of Sale

1. The property shall be sold to the highest bidder subject to the terms and conditions of the Magistrate's Court Act and the rules made thereunder and of the title deed in so far as these are applicable.

2. The following improvements on the property are reported, but nothing is guaranteed: 1 single storey dwelling, built of brick walls, under asbestos roof, consisting of 4 sub units with 4 w.c.'s.

3. *Payment:*

3.1. Ten per centum (10%) of the purchase price shall be paid in cash to or by means of a bank or building society guaranteed cheque to the Messenger of the Court or the auctioneer may arrange;

3.2. the unpaid balance shall be paid on registration of transfer in a form acceptable to the execution creditor's conveyancers;

3.3. interest shall be paid on—

3.3.1. the amount of Plaintiff's claim at the rate of 28% per annum for each month or part thereof from the date of sale to date of registration of transfer;

3.3.2. interest shall further be paid on any preferent creditors claim at the applicable rate from the date of sale to date of registration of transfer.

3.4. All the amounts mentioned in paragraphs 3.2. and 3.3. above are to be secured by the purchaser by approved banker's or building society guarantee to be delivered within fourteen (14) days of the date of sale to the execution creditor's conveyancers.

4. *Full Conditions of Sale:*

The full Conditions of Sale which will be read out by the Messenger of the Court or the auctioneer, immediately prior to the sale, may be inspected at either the Messenger of the Court or the auctioneer's office.

C. L. Faure, for Silberbauers, Plaintiff's Attorneys, United Building, 118 St George's Street, Cape Town.

Case 2281/87

IN THE MAGISTRATE'S COURT FOR THE DISTRICT OF KUILS RIVER HELD AT KUILS RIVER

In the matter between: **United Building Society Limited**, Judgment Creditor, and **Katrina Cornelia Oliphant**, Judgment Debtor

In pursuance of a Judgment in the Court of the Magistrate of Kuils River and Writ of Execution dated 2 July 1987 the following property will be sold in execution, in front of the Court-house of the District of Kuils River, on Tuesday, 10 November 1987 at 10h00, to the highest bidder:

Certain Erf 600 Kuils River, in the Municipality of Kuils River, Division of Stellenbosch.

Measuring Eight hundred and ninety eight (898) square metres.

Held Under Deed of Transfer No. 30062/1981.

Also Known As 35 Nooiensfontein Road, Kuils River, Cape.

Conditions of Sale

1. The Sale shall be subject to the terms and conditions of the Magistrate's Court Act, the Rules made thereunder and of the Title Deeds of the property and the property shall, subject to the foregoing, be sold to the highest bidder.
2. The following improvements on the property are reported but nothing is guaranteed: Lounge/dining room, kitchen, three bedrooms, bathroom/shower, separate toilet. Double garage.
3. *Payment:* Ten per centum of the purchase price shall be paid in cash at the time of the Sale and the full balance thereof together with interest at the current rate of Fourteen (14) per centum per annum calculated on the amount of the Judgement Creditor's claim (and in the event of there being any preferent creditor then also the interest payable upon such preferent creditor's claim) from the date of sale to the date of transfer, against registration of transfer, which amounts are to be secured by approved bank or building society guarantee to be delivered within fourteen (14) days of the date of sale.
4. The owner of the property is a member of the Coloured Group.
5. *Conditions:* The full Conditions of Sale which will be read out by the Messenger of the Court immediately prior to the Sale and may be inspected at his office.

L. J. le Roux, for Silberbauers, Attorneys for the Judgment Creditor, United Building, 118 St George's Street, Cape Town, 8001.

Case 3107/87

IN THE MAGISTRATE'S COURT FOR THE DISTRICT OF KUILS RIVER HELD AT KUILS RIVER

In the matter between: **United Building Society Limited**, Judgment Creditor, and **Charles Hilton Claasen**, Judgment Debtor

In pursuance of a Judgment in the Court of the Magistrate of Kuils River and Writ of Execution dated 21 August 1987, the following property will be sold in execution, in front of the Court-house of the District of Kuils River, on Monday, 9 November 1987 at 10h00, to the highest bidder:

Certain Erf 1558 Gaylee, in the Melton Rose Local Area, Administrative District of Stellenbosch.

Measuring Three hundred and twelve (312) square metres.

Held Under Deed of Transfer No. 10195/1987.

Also Known As 43 Rooiberg Street, Gaylee, Melton Rose, Cape.

Conditions of Sale

1. The Sale shall be subject to the terms and conditions of the Magistrate's Court Act, the Rules made thereunder and of the Title Deeds of the property and the property shall, subject to the foregoing, be sold to the highest bidder.
2. The following improvements on the property are reported but nothing is guaranteed: Kitchen, lounge, three bedrooms, bathroom/toilet.
3. *Payment:* Ten per centum of the purchase price shall be paid in cash at the time of the Sale and the full balance thereof together with interest at the current rate of Fourteen (14) per centum per annum calculated on the amount of the Judgement Creditor's claim (and in the event of there being any preferent creditor then also the interest payable upon such preferent creditor's claim) from the date of sale to the date of transfer, against registration of transfer, which amounts are to be secured by approved bank or building society guarantee to be delivered within fourteen (14) days of the date of sale.
4. The owner of the property is a member of the Coloured Group.
5. *Conditions:* The full Conditions of Sale which will be read out by the Messenger of the Court immediately prior to the Sale and may be inspected at his office.

L. J. le Roux, for Silberbauers, Attorneys for the Judgment Creditor, United Building, 118 St George's Street, Cape Town, 8001.

Case 3218/87

IN THE MAGISTRATE'S COURT FOR THE DISTRICT OF GOODWOOD HELD AT GOODWOOD

In the matter between: **United Building Society Limited**, Judgment Creditor, and **Patrick William Labuschagne**, Judgment Debtor

In pursuance of a Judgment in the Court of the Magistrate of Goodwood and Writ of Execution dated 20 May 1987 the following property will be sold in execution, at the site, Erf 2 Richmond Park, (sand-road 200m from intersection Woodlands Avenue/Annandale Drive, Richwood, Cape), on Wednesday, 11 November 1987 at 12h00, to the highest bidder:

Certain Erf 2 Richmond Park, situate in the Cape Division.

Measuring Five thousand nine hundred and forty eight (5 948) square metres.

Held Under Deed of Transfer No. 20406/1986.

Also Known As Erf 2 Richmond Park (sand-road 200m from intersection Woodlands Avenue/Annandale Drive, Richwood, Cape).

Conditions of Sale

1. The Sale shall be subject to the terms and conditions of the Magistrate's Court Act, the Rules made thereunder and of the Title Deeds of the property and the property shall, subject to the foregoing, be sold to the highest bidder.
2. The following improvements on the property are reported but nothing is guaranteed: Double storey dwelling: Hall, lounge, diningroom, family room, study, kitchen, four bedrooms, bath/shower and toilet, shower and toilet. Servant's room, bath/toilet. Two single garages.
3. *Payment:* Ten per centum of the purchase price shall be paid in cash at the time of the Sale and the full balance thereof together with interest at the current rate of Fourteen (14) per centum per annum calculated on the amount of the Judgement Creditor's claim (and in the event of there being any preferent creditor then also the interest payable upon such preferent creditor's claim) from the date of sale to the date of transfer, against registration of transfer, which amounts are to be secured by approved bank or building society guarantee to be delivered within fourteen (14) days of the date of sale.
4. The owner of the property is a member of the White Group.
5. *Conditions:* The full Conditions of Sale which will be read out by the Messenger of the Court immediately prior to the Sale and may be inspected at his office.

L. J. le Roux, for Silberbauers, Attorneys for the Judgment Creditor, United Building, 118 St George's Street, Cape Town, 8001.

IN THE MAGISTRATE'S COURT FOR THE DISTRICT OF GOODWOOD HELD AT GOODWOOD

In the matter between: **United Building Society Limited**, Judgment Creditor, and **Fransoa Ebersohn**, First Judgment Debtor and **Johanna Susara Aletta Ebersohn**, Second Judgment Debtor

In pursuance of a Judgment in the Court of the Magistrate of Goodwood and Writ of Execution dated 8 August 1987 the following property will be sold in execution, at the site being 30 Woodlands Avenue, Richwood, Cape on Wednesday, 11 November 1987 at 11h00, to the highest bidder:

Certain Erf 1103, a portion of Erf 869, Richmond Park, in the Municipality of Milnerton, Cape Division.

Measuring Four hundred and ninety six (496) square metres.

Held Under Deed of Transfer No. 20322/1986.

Also Known As 30 Woodlands Avenue, Richwood, Cape.

Conditions of Sale

1. The Sale shall be subject to the terms and conditions of the Magistrate's Court Act, the Rules made thereunder and of the Title Deeds of the property and the property shall, subject to the foregoing, be sold to the highest bidder.

2. The following improvements on the property are reported but nothing is guaranteed: Hall, lounge, diningroom, kitchen, laundry, three bedrooms, bath/toilet.

3. *Payment*: Ten per centum of the purchase price shall be paid in cash at the time of the Sale and the full balance thereof together with interest at the current rate of Fourteen (14) per centum per annum calculated on the amount of the Judgement Creditor's claim (and in the event of there being any preferent creditor then also the interest payable upon such preferent creditor's claim) from the date of sale to the date of transfer, against registration of transfer, which amounts are to be secured by approved bank or building society guarantee to be delivered within fourteen (14) days of the date of sale.

4. The owners of the property are members of the White Group.

5. *Conditions*: The full Conditions of Sale which will be read out by the Messenger of the Court immediately prior to the Sale and may be inspected at his office.

L. J. le Roux, for Silberbauers, Attorneys for the Judgment Creditor, United Building, 118 St George's Street, Cape Town, 8001.

Case 14345/87

IN THE MAGISTRATE'S COURT FOR THE DISTRICT OF THE CAPE HELD AT CAPE TOWN

In the matter between: **United Building Society Limited**, Judgment Creditor, and **Alan Vincent Haynes**, Judgment Debtor

In pursuance of a Judgment in the Court of the Magistrate of Cape Town and Writ of Execution dated 24 August 1987 the following property will be sold in execution at the site, 76 Heron Waters, Blaauwberg Road, Table View, Cape, on Thursday, 12 November 1987 at 10h00, to the highest bidder:

1.1 (a) Section 32 as shown and more fully described on Sectional Plan No. 158/1986 in the building or buildings known as Heron Waters of which the floor area according to the Sectional Plan is eighty two (82) square metres in extent and

(b) An undivided share in the common property in the land or building or buildings as shown and more fully described on the said Sectional Plan apportioned to the said Section in accordance with the participation quota of the said Section.

Held Under Certificate of Registered Sectional Title No. 158/1986 (32) (Unit).

Also Known As 76 Heron Waters, Blaauwberg Road, Table View, Cape.

Conditions of Sale

1. The Sale shall be subject to the terms and conditions of the Magistrate's Court Act, the Rules made thereunder and of the Title Deeds of the property and the property shall, subject to the foregoing, be sold to the highest bidder.

2. The following improvements on the property are reported but nothing is guaranteed: Lounge, three bedrooms, kitchen, bath/toilet.

3. *Payment*: Ten per centum of the purchase price shall be paid in cash at the time of the Sale and the full balance thereof together with interest at the current rate of Fourteen (14) per centum per annum calculated on the amount of the Judgement Creditor's claim (and in the event of there being any preferent creditor then also the interest payable upon such preferent creditor's claim) from the date of sale to the date of transfer, against registration of transfer, which amounts are to be secured by approved bank or building society guarantee to be delivered within fourteen (14) days of the date of sale.

4. The owner of the property is a member of the White Group.

5. *Conditions*: The full Conditions of Sale which will be read out by the Messenger of the Court immediately prior to the Sale and may be inspected at his office.

L. J. le Roux, for Silberbauers, Attorneys for the Judgment Creditor, United Building, 118 St George's Street, Cape Town, 8001.

Case 18916/87

IN THE MAGISTRATE'S COURT FOR THE DISTRICT OF WYNBERG HELD AT WYNBERG

In the matter between: **Allied Building Society Limited**, Execution Creditor, and **A. G. Hoole**, Execution Debtor

In Terms of a Judgment granted by the Magistrate's Court for the District of Wynberg dated 29th July 1987 and a Warrant of Execution dated 29th July 1987 the undermentioned property will be sold voetstoots and without reserve in execution by Public Auction held on the premises, to the highest bidder on 30th October, 1987 at 10.00 o'clock.

Erf 79421 Cape Town at Diep River in the City of Cape Town, Cape Division;

In Extent: 495 Square Metres:

Address: 19 Talent Street, Diep River, Cape.

Conditions of Sale

(1) The property will be sold in execution without reserve and voetstoots to the highest bidder by Public Auction and subject to the provisions and conditions of the Magistrate's Court Act No. 32 of 1944 as amended and the Rules applicable thereto and also the servitudes and conditions attaching to the property contained in the relevant Title Deeds.

(2) The following information is furnished but not guaranteed: "Timber clad single storey dwelling with garage."

(3) The full and complete conditions of sale will be announced by the Auctioneers, S. M. Sass & Company, 203 Avlew Place, Grove Avenue, Claremont, Cape immediately before the sale and will lie for inspection at the offices of the Messenger of the Court, Wynberg and at the offices of the Auctioneers.

(4) Payment shall be effected as follows:

Ten Per Cent (10%) of the purchase price on the day of the sale and the balance together with interest thereon at the rate of fourteen per cent (14%) from the date of sale to date of registration of transfer against transfer of the property into the name of the purchaser, which payment shall be secured by an approved Bank or Building Society guarantee within Fourteen (14) days of the date of sale.

Dated at Cape Town on this 17th day of August 1987.

Buchanan Boyes & Klossers, Attorneys for Execution Creditor, St George's Centre, 13 Hout Street, Cape Town (A. L. N. Berrangé).

Case 22375/86

IN THE MAGISTRATE'S COURT FOR THE DISTRICT OF WYNBERG HELDA AT WYNBERG

In the matter between: **Cordel**, Judgment Creditor, and **Jonbyar t/a Ulti Furniture Manufacturers**, Judgment Debtor

In pursuance of a judgment in the Court of the Magistrate for the district of Wynberg, dated the 21st August 1986, and Writ of Execution dated 13th August 1987, the following will be sold in execution at 2.30 p.m. on the 24th November 1987 at the site being:

Erf 38760, Cape Town, at Athlone, in the City of Cape Town, Cape Division;

In Extent Four Hundred and Forty-Six (446) Square Metres;

Held By Deed of Transfer No. T3066/1979;

Also Known As 26 Limirick Road, Crawford.

Conditions of Sale

1. The property shall be sold to the highest bidder subject to the terms and conditions of the Magistrate's Court Act and the rule made thereunder and of the title deed in so far as these are applicable.

2. The following improvements on the property are reported, but nothing is guaranteed:

3. *Description of the Property*

Consisting of brick walls under asbestos roof, with 1 x Lounge/Diningroom, 1 x Kitchen, 3 x Bedrooms, 1 x Bathroom and Toilet, 1 x outside garage.

4. *Payment*

4.1. Ten per centum (10%) of the purchase price shall be paid in cash or by means of a bank or Building Society guaranteed cheque to the Messenger of the Court or the Auctioneer upon signature of the Conditions of Sale, or otherwise as the Messenger of the Court or the Auctioneer may arrange;

4.2. the unpaid balance shall be on registration of transfer in a form acceptable to the Execution Creditor's Conveyancers;

4.3. Interest shall be paid on:

4.3.1. the balance of the purchase price from date of sale to date of registration of transfer at ruling Building Society rates of interest on the amount of the balance outstanding;

4.3.2. any preferent creditor's claim at the applicable rate of interest from date of sale to date of registration of transfer.

4.4. All the amounts mentioned in paragraph 4.2. and 4.3. above are to be secured by the Purchaser by approved banker's or Building Society guarantee to be delivered within fourteen (14) days of the sale to the Execution Creditor's Conveyancers.

Full Conditions of Sale

The full conditions of sale which will be read out by the Messenger of the Court or the Auctioneer, immediately prior to the sale, may be inspected at either the Messenger of the Court or the Auctioneer's office.

Dated at Cape Town, this 17th day of September 1987.

Simon Abel & Son, Attorneys for Execution Creditor, Sam Newman House, 67 Long Street, Cape Town.

Case 1734/87

IN THE MAGISTRATE'S COURT FOR THE DISTRICT OF KUILS RIVER HELD AT KUILS RIVER

In the matter between **Allied Building Society Ltd**, Plaintiff, and **R. J. MacDougall**, Defendant

In the above matter a sale will be held on the 16th November 1987 at 10h00 at 15 Brandwood Avenue, Kuils River, at the site being: Erf 2443, Kuils River, in the Municipality of Kuils River, Division of Cape; measuring (504) five hundred and four square metres.

Conditions of Sale

1. The sale is subject to the terms and conditions of the Magistrate's Court Act, No. 32 of 1944, the property being sold voetstoots and as it stands and subject to the conditions of the existing Title Deed.

2. The purchase price for the property shall be paid in the following manner:

(a) One-tenth of the purchase price in cash or by means of a bank initialled cheque in favour of the Messenger of the Court shall be paid to the Messenger of the Court on the day of the sale;

(b) The balance of the purchase price together with interest thereon at ruling building society rates from date of sale to date of payment shall be paid to the transfer attorneys free of exchange at Kuils River against registration to transfer;

and the Purchaser shall within fourteen (14) days of the date of sale furnish the transfer attorneys with a bank or building society guarantee to the satisfaction of such attorneys for the due payment of the balance of the purchase price and interest.

3. The property is reserved for the use of the members of the White Group.

4. The following improvements are on the property:

A single-storey brick dwelling comprising of lounge, dining-room, 3 bedrooms, kitchen, bathroom and toilet, 1 garage (although nothing in this respect is guaranteed).

5. The complete Conditions of Sale will be read out at the time of the sale and may be inspected prior thereto at the office of the Messenger of the Court, Bellville, and at the offices of the undersigned.

Dated at Kuils River this 5th day of October 1987.

A. van Eeden, for Hickman & Van Eeden, Attorneys for Plaintiff, Elim Centre, corner of Carinus Street and Van Riebeeck Road, Kuils River.

IN THE SUPREME COURT OF SOUTH AFRICA

(Cape of Good Hope Provincial Division)

Between **Umdloti Strand Hotel (Pty) Limited**, Execution Creditor, and **Specified Steel Profiles (Pty) Limited**, First Execution Debtor, **Jan Oosthuizen**, Second Execution Debtor, and **Jean Oosthuizen**, Third Execution Debtor

The property described hereunder will be sold on Thursday 5th November 1987 at 14h00 at Glen Heights, Silverhurst Drive, Constantia, Cape Province, namely:

Erf 5946 Constantia in the local area of Constantia, Division of the Cape;

In extent: One Thousand Five Hundred and One (1 501) square metres;

Held by the Second Execution Debtor by Deed of transfer T. 27434/1982.

A dwelling is situate on the said property which, without warranty, is said to be a single storey brick dwelling with a tiled roof consisting of lounge/dining room combined, three bedrooms, one kitchen, two bathrooms, two toilets, double garage with maid's quarters consisting of a room with a bathroom.

The property will be sold to the highest bidder, voetstoots and without warranty of possession, the price being payable either in cash on sale or as to ten per centum (10%) of the price in cash on sale and the balance against transfer plus interest on any unpaid balance at the rate of 15% per annum from one (1) month after the date of sale, such balance to be secured by an approved guarantee for payment thereof within fourteen (14) days of sale. The buyer shall:

- (a) Pay Auctioneers charges, transfer dues, costs of transfer, arrear rates and water charges if any, necessary to enable transfer to be given;
- (b) Obtain within six (6) weeks of sale, if necessary, a permit under the Group Areas Act and a certificate under the Group Area Development Act;
- (c) Insure the property against damage by fire;
- (d) Be liable on cancellation in case of default for damages including wasted costs.

The full conditions of sale will be announced at the sale and may be inspected at the offices of the Deputy Sheriff, Wynberg, and Fairbridge Arderne & Lawton Incorporated at the address below.

Fairbridge Arderne & Lawton Incorporated, Attorneys for the Execution Creditor, 4th Floor, Main Tower, Cape Town Centre, Heerengracht, Cape Town. Telephone: 21-5120. Reference: L. G. Rood.

NATAL

IN THE MAGISTRATE'S COURT FOR THE DISTRICT OF PORT SHEPSTONE HELD AT PORT SHEPSTONE

In the matter between **Natal Building Society Limited**, Plaintiff, and **Denleigh Craig de Saxe**, Defendant

In pursuance of a Judgment in the Court of the Magistrate at Port Shepstone and a Warrant of Execution issued pursuant thereto on 7 August 1987, the immovable property known as—

Sub 6 of Lot 476 Umtentweni, situate in the Township of Umtentweni and in the Lower South Coast Regional Water Services Area, Administrative District of Natal, in extent two thousand and fifteen (2 015) square metres,

will be sold in execution on Friday, 30 October 1987 at 10h00 in front of the Court House, Port Shepstone, on terms and conditions which will be read at the time of the sale and which may in the meantime be inspected at the Office of the Messenger of the Court, 6 Archibald Street, Port Shepstone, or at the office of Messrs. Forder Ritch Pfaff & Redpath, the Plaintiff's Attorneys, 1 Court House Road, Port Shepstone. The material terms and conditions of the sale are as follows:

(1) The purchaser shall pay ten (10 %) per centum of the purchase price immediately after the sale and shall furnish a Bank or Building Society guarantee acceptable to the Plaintiff's Attorneys securing the balance plus the interest referred to below within fourteen (14) days after the sale.

(2) In addition to the purchase price, the Purchaser shall pay all transfer costs, all arrear rates and penalties and collection charges (if any) thereon, and interest to the Plaintiff on R65 075 (sixty five thousand and seventy five rand) at 14,5 % (fourteen comma five) per centum per annum from the date of the sale to the date on which the transfer of the property into the name of the Purchaser is registered, both days inclusive.

The property is situate in Milton Road in Umtentweni and the following information is supplied in respect of improvements on the property but nothing is guaranteed in this regard:

There is a main building and an outbuilding on the property. The main building consists of a house and a self-contained flat with its own entrance and a double garage. The house consists of 3 bedrooms, 2 bathrooms, combined lounge/dining room and kitchen. The flat consists of 1 bedroom, kitchen and bathroom. The outbuilding consists of a laundry room and servants room with shower and toilet.

Forder, Ritch Pfaff & Redpath, Attorneys for Plaintiff, 1 Court House Road, P.O. Box 32, Port Shepstone, 4240.

IN DIE LANDDROSHOF VIR DIE DISTRIK VAN NEWCASTLE

In die saak tussen **Die Stadtesourier van die Stadsraad van Newcastle**, Eksekusieskuldeiser, en **Mev. M. A. Vermeulen**, Eksekusieskuldenaar

Ingevolge uitspraak van bogenoemde Agbare Hof en 'n Lasbrief vir Eksekusie teen onroerende goed gedateer 26 Augustus 1987 word die onder vermelde eiendom om 10h00 op 4 November 1987 in die voorkamer van die Landdroshof, Newcastle geregteelik verkoop, nl:

Erf 2896, Newcastle.

Die eiendom bestaan uit 'n woonhuis met verbeterings daarop maar niks word gewaarborg nie.

Die verkoopvoorwaardes is ter insae by die kantore van die Geregsbode van Newcastle te Nedbanksentrum, Hardingstraat, Newcastle en is onder andere die volgende:

1. Die eiendom sal deur die Geregsbode van Newcastle by wyse van openbare veiling aan die hoogste bieder verkoop word, maar sodanige verkoping is onderhewig aan bekragtiging deur die vonnisskuldeiser of sy prokureurs binne 10 dae vanaf datum van die verkoping.

2. Die koper sal 'n deposito betaal van 10 % van die koopprys op tekening van die verkoopvoorwaardes en die balans van die koopprys plus rente teen 15 % per jaar vanaf die datum van verkoping tot op datum van registrasie van transport sal gewaarborg word by wyse van 'n goedgekeurde Bank of Bouvereniging waarborg wat gelewer moet word aan die Eksekusieskuldeiser se prokureurs binne veertien dae vanaf die datum van verkoping.

3. Die eiendom is gesoneer vir bewoning deur blankes en word verkoop onderhewig aan die voorwaardes soos vervat in die titelakte daarvan.

Gedateer te Newcastle op hede die 21ste dag van September 1987.

P. G. Steyn, vir De Jager, Kloppers & Steyn, Prokureurs vir Eksekusieskuldeiser, Vierde Vloer, United Gebou, Scottstraat 52, Newcastle.

IN THE SUPREME COURT OF SOUTH AFRICA

(Natal Provincial Division)

In the matter between **L. G. Green (Pty) Ltd**, Plaintiff, and **C. F. de Lange**, trading as **S. K. de Lange**, Defendant

Please take notice that the undermentioned property will be sold by Public Auction by P. C. Harwood, the Acting Deputy Sheriff for the District of Pietermaritzburg on Saturday the 31st day of October 1987 at 09.00 a.m., on 176 Loop Street, Pietermaritzburg,

namely:

Remainder of Sub 2 of Lot 2141 Pietermaritzburg situate in the City of Pietermaritzburg, Administrative District of Natal in extent five hundred and forty one (541) square metres.

The postal address of the property is 413 Boom Street, Pietermaritzburg, Natal.

The property has been improved by the erection of buildings thereon full details of which may be obtained by inspecting the Conditions of Sale.

The conditions of sale may be inspected at the Office of the Deputy Sheriff, Pietermaritzburg, 176 Loop Street, Pietermaritzburg, as from the date of publication hereof.

Dated at Pietermaritzburg this 6th day of October 1987.

Errol W. Stowell & Company, Plaintiff's Attorneys, Seventh Floor, Shepstone, Chancery Lane, Pietermaritzburg.

Saak 2316/87

IN DIE LANDDROSHOF VIR DIE DISTRIK VAN NEWCASTLE

In die saak tussen **Nywerheid-ontwikkelingskorporasie van S.A. Beperk**, Eksekusieskuldeiser, en **Andre Johannes Smith**, en **Helen Elizabeth Smith**, Eksekusieskuldenaars

Ingevolge uitspraak van bogenoemde Agbare Hof en 'n Lasbrief vir Eksekusie teen onroerende goed gedateer 24 Augustus 1987 word die onder vermelde eiendom om 10h00 op 4 November 1987 in die voorkamer van die Landdroshof, Newcastle geregtelik verkoop, nl:

Onderverdeling 3 van Perseel 794, Newcastle.

Die eiendom bestaan uit 'n woonhuis met verbeterings daarop maar niks word gewaarborg nie.

Die verkoopsvoorwaardes is ter insae by die kantore van die Geregsbode van Newcastle te Nedbanksentrum, Hardingstraat, Newcastle en is onder andere die volgende:

1. Die eiendom sal deur die Geregsbode van Newcastle by wyse van openbare veiling aan die hoogste bieder verkoop word, maar sodanige verkoping is onderhewig aan bekragtiging deur die vonnisuldeiser of sy prokureurs binne 10 dae vanaf datum van die verkoping.

2. Die koper sal 'n deposito betaal van 10 % van die koopprijs op tekening van die verkoopsvoorwaardes en die balans van die koopprijs plus rente teen 16 % per jaar vanaf die datum van verkoping tot op datum van registrasie van transport sal gewaarborg word by wyse van 'n goedgekeurde Bank of Bouvereniging waarborg wat gelewer moet word aan die Eksekusieskuldeiser se prokureurs binne dertig dae vanaf die datum van verkoping.

3. Die eiendom is gesoneer vir bewoning deur blankes en word verkoop onderhewig aan die voorwaardes soos vervat in die titelakte daarvan.

Gedateer te Newcastle op hede die 5de dag van Oktober 1987.

P. G. Steyn, vir De Jager, Kloppers & Steyn, Prokureurs vir Eksekusieskuldeiser, 4de Vloer, United Gebou, Scottstraat 52, Newcastle.

Case 2002/87

IN THE MAGISTRATE'S COURT FOR THE DISTRICT OF CHATSWORTH HELD AT CHATSWORTH

In the matter between **United Building Society Limited**, No. 86/04794/06, Execution Creditor, and **Munusami Pillay**, Execution Debtor

In pursuance of a Judgment granted on 20th May 1987 in the Court of the Magistrate, Chatsworth and under a Writ of Execution issued thereafter, the immovable property listed hereunder will be sold in execution on Tuesday, 27th October 1987 at 10.00 a.m., in front of the Magistrate's Court, Chatsworth to the highest bidder.

Description: A certain piece of land being:

Lot 1666 Shallcross (Extension 1), situate in the Development Area of Shallcross, County of Durban, Province of Natal, in extent four hundred and sixty five (465) square metres.

Now known as:

Lot 1666 Shallcross (Extension 1), situate in the Development Area of Shallcross, Administrative District of Natal, in extent four hundred and sixty five (465) square metres.

Postal address: 42 Simla Street, Shallcross.

Improvements: 1 Block under tile roof dwelling comprising of 3 bedrooms, lounge, kitchen, toilet and bathroom.

Town Planning—Zoning: Special Residential; Special Privileges: Nil.

Group Area Act: Group entitled to occupy: Indian.

Nothing is guaranteed in these respects

Material conditions:

1. The sale shall be subject to the terms and conditions of the Magistrate's Court Act and the Rules made thereunder.
2. The purchaser shall pay a deposit of 10 % of the purchase price in cash at the time of the sale, the balance against transfer to be secured by a Bank or Building Society guarantee to be approved by the Plaintiff's Attorneys to be furnished to the Court Messenger within fourteen (14) days after the date of sale.

3. The attention of all prospective purchasers is directed to the provisions of the Group Areas Act.

4. If more than one property is to be sold, the properties may be purchased separately, unless this is precluded by the conditions of title or law.

The full conditions may be inspected at the offices of the Messenger of the Court, Chatsworth or at our offices.

C. M. Kenton, for Browne, Brodie & Co., Plaintiff's Attorneys, c/o Ash Haripersad & Partners, 1st Floor, Montford Service Station, 160 Road 701, Chatsworth.

IN THE MAGISTRATE'S COURT FOR THE DISTRICT OF DURBAN HELD AT DURBAN

In the matter between **United Building Society**, Plaintiff, and **T. & I. Jhagaroo**, Defendant

In pursuance of a Judgment in the Magistrate's Court, Durban 2nd April 1987, and a writ of execution dated 3 April 1987 the undermentioned property will be sold in execution on the 30th day of October 1987 at 10h00 in front of the Magistrate's Court, Somtseu Road, Durban, the highest bidder:

Property description: Lot 2465 Isipingo (Extension 19) situate in the Borough of Isipingo and in the Amanzimtoti Regional Water Services Area, Administrative District of Natal in extent eight hundred and thirty six (836) square metres.

Consisting of: Brick under tile dwelling—lounge, diningroom, open plan kitchen, 3 bedrooms en suite, 1 bedroom, scullery separate dormes—roof area with staircase, balcony single garage, servant's quarters, incomplete swimming pool.

Postal address: 39 Barracuda Drive, Isipingo Beach.

Town Planning: Residential.

But nothing is guaranteed in these respects.

1. The property shall be sold to the highest bidder and shall be subject to the terms and conditions of the Magistrate's Court Act and the rules made thereunder and of the Title Deeds in so far as these are applicable.

2. The purchaser shall pay ten percent (10 %) of the purchase price in cash immediately after the sale and the balance shall be paid or secured by a satisfactory Bank or Building Society guarantee to be approved by the Plaintiff's Attorneys, to be furnished to the Court Messenger, Durban District within fourteen days (14) of the date of sale.

3. Attention of the prospective purchasers is directed to the provisions of the Group Areas Act. The property is in an Indian Group Area.

4. The purchaser shall pay auctioneer's charges on the date of sale and in addition transfer dues, costs of transfer plus arrear rates and any other charges necessary to effect transfer upon request by the Attorney for the Execution Creditor.

The full conditions of sale may be inspected at the office of the Messenger of the Court, Durban South, 101 Lejaton, 40 St George's Street, Durban.

Dated at Durban this 15th day of September 1987.

S. W. van den Bosch & Company, Plaintiff's Attorneys, 8th Floor, AA Mutual House, 447 Smith Street, Durban, 4001.

Case 965/86

IN THE SUPREME COURT OF SOUTH AFRICA

(Durban and Coast Local Division)

In the matter between **Syfre's Mortgage Nominees Limited**, Plaintiff, and **Seray Investments (Pty) Limited**, First Defendant; **Edmund Gerald Anand Ray**, Second Defendant; **Sarasvathy Ray**, Third Defendant

In pursuance of a Judgment of the Supreme Court of South Africa dated the 2nd day of June 1986 and a Writ of Execution issued thereafter, the immovable property listed hereunder will be sold in execution on the 30th day of October, 1987 at 10h00 outside the front entrance of the Verulam Magistrate's Court, Verulam.

Title Deed Description:

Lots 58, 59 and 60 Desainagar situate in the Township of Tongaat and in the North Coast Regional Water Services Area, Administrative District of Natal in extent four hundred and sixty eight square metres (468 m²), four hundred and forty seven square metres (447 m²) and five hundred and fifty four square metres (554 m²) respectively.

Postal address: 58 Park Avenue, Desainagar Township.

Improvements: (but nothing is guaranteed in respect thereof).

Business known as Sunray consisting of three offices, one hall, two storerooms, four toilets, one bar brick and tile, lights and water (please note that the business itself is not sold together with the immovable property. Only the fixed improvements).

1. The sale shall be subject to the terms and conditions of the Supreme Court Act and the Rules made thereunder.

2. No bid will be accepted by or on behalf of a person who is not a member of the Indian Group and the purchaser (other than the Execution Creditor) shall pay a deposit of 10 % of the purchase price in cash at the time of the sale.

3. The balance of the purchase price is payable against transfer to be secured by a Bank or Building Society guarantee approved by the Execution Creditor's Attorneys and to be furnished within fourteen days after the date of sale.

4. The purchaser shall be liable for the payment of interest to the execution creditor and to the bondholder (if any) from date of sale to date of registration of transfer, as set out in the Conditions of Sale.

5. Transfer shall be effected by the Attorneys for the execution creditor and the purchaser shall pay all transfer costs, including arrear and current rates, sewerage connection fees (if any), taxes and other charges necessary to effect transfer on request by the said attorneys.

6. The full conditions of sale may be inspected at the offices of the Deputy Sheriff, Verulam.

Dated at Durban this day of 1987.

De Villiers Evans & Petit, Plaintiff's Attorneys, 501 NBS Building, 300 Smith Street, Durban. (Mr Brauteseth/3307/86).

Case 49347/86

IN THE MAGISTRATE'S COURT FOR THE DISTRICT OF DURBAN HELD AT DURBAN

In the matter between **Ovland Centre (Durban) (Pty) Ltd**, Plaintiff, and **Frederick Johannes Beeslaar**, Defendant

In pursuance of a Judgment granted on the 16th January 1987 in the Magistrate's Court, Durban and under a Warrant of Execution issued thereafter, the immovable property listed hereunder will be sold in Execution on the 6th day of November 1987 at 11.00 a.m., at the front entrance to the Magistrate's Court Building, Moss Street, Verulam.

Description: A certain piece of land being Lot 1207 La Lucia Township, being known as 129 Forest Drive, La Lucia, situate in the Administrative District of Natal, Borough of Umhlanga and in the North Coast Regional Water Services Area, measuring one thousand three hundred and one (1 301) square metres.

Address: 129 Forest Drive, La Lucia.

Improvements: Concrete roof and brick dwelling comprising of:

2 Bathrooms and toilets; 1 diningroom, 1 lounge; 1 kitchen; 1 TV room and 1 playroom; 3 bedrooms;

Group Areas Act: Group entitled to occupy: White.

Nothing is guaranteed in these respects.

Material conditions:

1. The sale shall be subject to the terms and conditions of the Magistrate's Court Act and the Rules made thereunder.

2. The purchaser shall pay a deposit of 10 % of the purchase price in cash at the time of the sale, the balance against transfer to be secured by a Bank or Building Society guarantee to be approved by the Plaintiff's Attorneys to be furnished to the Court Messenger within fourteen (14) days after the date of sale.

3. The attention of all prospective purchasers is directed to the provisions of the Group Areas Act.

4. If more than one property is to be sold, the properties may be purchased separately, unless this is precluded by the conditions of title or law.

The full conditions may be inspected at the offices of the Messenger of Court, Verulam, or at the offices of Leandy & Partners.

Leandy & Partners, Plaintiff's Attorneys, 5th Floor, JBS/Allied Building, Cnr West and Field Streets, Durban.

Case 27161/87

IN THE MAGISTRATE'S COURT FOR THE DISTRICT OF DURBAN HELD AT DURBAN

In the matter between **United Building Society**, Plaintiff, and **H. & M. Strydom**, Defendant

In pursuance of a Judgment in the Magistrate's Court, Durban, 31 July 1987 and a writ of execution dated 7 August 1987, the undermentioned property will be sold in execution on the 30th day of October 1987 at 10h00 in front of the Magistrate's Court, Somtseu Road, Durban, the highest bidder:

Property description: Section 10 as shown and more fully described on Sectional Plan 43/1978 in building or buildings known as Kingsley Gardens of which the floor area according to the said sectional plan is one hundred and thirty two (132) square metres.

Consisting of: 1 Kitchen, 1 lounge/diningroom, 1 enclosed verandah, 1 bedroom with en-suite and built in cupboards, 2 rooms with built in cupboards, 1 toilet and bathroom.

Town planning: Residential.

Postal address: 10 Kingsley Gardens, Kingsley Terrace, Amanzimtoti.

But nothing is guaranteed in these respects.

1. The property shall be sold to the highest bidder and shall be subject to the terms and conditions of the Magistrate's Court Act and the Rules made thereunder and of the Title Deeds in so far as these are applicable.

2. The purchaser shall pay ten percent (10 %) of the purchase price in Cash immediately after the sale and the balance shall be paid or secured by a satisfactory Bank or Building Society guarantee to be approved by the Plaintiff's Attorneys, to be furnished to the Court Messenger, Durban District within fourteen days (14) of the date of sale.

3. Attention of the prospective purchasers is directed to the provisions of the Group Areas Act. The property is in a White Group Area.

4. The purchaser shall pay auctioneer's charges on the date of sale and in addition transfer dues, costs of transfer plus arrear rates and any other charges necessary to effect transfer upon request by the Attorney for the Execution Creditor.

The full conditions of sale may be inspected at the office of the Messenger of the Court, Durban South, 101 Lejaton, 40 St George's Street, Durban.

Dated at Durban this 18th day of September 1987.

S. W. van den Bosch & Company, Plaintiff's Attorneys, 8th Floor, AA Mutual House, 447 Smith Street, Durban, 4001.

Case 17601/87

IN THE MAGISTRATE'S COURT FOR THE DISTRICT OF DURBAN HELD AT DURBAN

In the matter between **United Building Society**, Plaintiff, and **David Greenwood**, Defendant

In pursuance of a Judgment in the Magistrate's Court, Durban 31 July 1987 and a writ of execution dated 7 August 1987, the undermentioned property will be sold in execution on the 30th day of October 1987 at 10h00 in front of the Magistrate's Court steps, Somtseu Road, Durban, to the highest bidder:

Property description: Section 29 as shown and more fully described on Sectional Plan 43/1984 in the building or buildings known as Miland Court of which the floor area according to the said sectional plan is fifty four (54) square metres.

Consisting of: 1 Kitchen, 1 diningroom, 1 sleeping porch, 1 bathroom and toilet, 1 closed porch.

Town Planning: Residential.

But nothing is guaranteed in these respects.

1. The property shall be sold to the highest bidder and shall be subject to the terms and conditions of the Magistrate's Court Act and the rules made thereunder and of the Title Deeds in so far as these are applicable.

2. The purchaser shall pay ten percent (10%) of the purchase price in cash immediately after the sale and the balance shall be paid or secured by a satisfactory Bank or Building Society guarantee to be approved by the Plaintiff's Attorneys, to be furnished to the Court Messenger, Durban District within fourteen days (14) of the date of sale.

3. Attention of the prospective purchasers is directed to the provisions of the Group Areas Act. The property is in a White Group Area.

4. The purchaser shall pay auctioneer's charges on the date of sale and in addition transfer dues, costs of transfer plus arrear rates and any other charges necessary to effect transfer upon request by the Attorney for the Execution Creditor.

The full conditions of sale may be inspected at the office of the Messenger of the Court, Durban South, 101 Lejaton, 40 St George's Street, Durban.

Dated at Durban this 18th day of September 1987.

S. W. van den Bosch & Company, Plaintiff's Attorneys, 8th Floor, AA Mutual House, 447 Smith Street, Durban, 4001.

IN THE SUPREME COURT OF SOUTH AFRICA

(Durban and Coast Local Division)

In the matter between **Swiftprops Proprietary Limited**, Plaintiff, and **Leo Nigel Smitbers**, First Defendant; **David Walter Woodland**, Second Defendant

In pursuance of a Judgment of the above Honourable Court, dated the 3rd April 1987 and under a Writ of Execution issued thereafter, the immovable property listed hereunder shall be sold in execution to the highest bidder on the 30th October 1987 at 10h00 on the steps of the entrance to the Supreme Court, Masonic Grove, Durban, on conditions to be read out by the Deputy Sheriff on day of the sale.

Description: Lot 2289 of Lot 14, No. 1547, situate in the City of Durban, Administrative District of Natal, in extent 1 Rood (1 012 square metres) one thousand and twelve square metres.

Postal address: 43 Balmoral Drive, Durban North.

Improvements: A single storey dwelling with plastered walls under tile roof, entrance hall, back porch, lounge/diningroom, four rooms, one kitchen, one separate toilet, one bathroom, one shower/toilet off main bedroom, one bar, one single garage under main tile roof with plastered walls, servant's quarters of one room with one toilet/shower, one swimming pool.

Group Areas Act:

Group entitled to purchase: White.

Town Planning Zoning: Special residential (minimum plot size nine hundred square metres).

Special privileges: Nil

Nothing is guaranteed in the above respects.

1. The purchaser shall pay a deposit of 10 % of the purchase price and the Auctioneer's Commission in cash immediately after the sale and the balance against a transfer to be secured by a Bank or Building Society Guarantee to be furnished to the Deputy Sheriff within fourteen days after the sale to be approved by the Plaintiff's Attorneys.

2. The purchaser shall be liable for payment of interest at the rate of 15 % per annum to the Execution Creditor and to the Bondholder/s at a prescribed rate of interest on the respective amounts of the awards to the Execution Creditor and to the Bondholder/s in the Plan of Distribution from the date of sale to date of transfer.

3. Inasmuch as the Second Defendant is the member of the White group, no bids will be accepted by or on behalf of a person who is not a member of such Group unless such person exhibits to the Auctioneer, at the sale, a permit authorising him to acquire such property which is in a proclaimed White area.

4. Transfer shall be effected by the attorneys of the Plaintiff and the Purchaser shall pay all the transfer dues including transfer duty, current and any arrear rates, and other necessary charges to effect transfer upon request by the said attorneys.

5. The full conditions of sale may be inspected at the offices of the Deputy Sheriff, Durban, at 1103 Sanlam Centre, 331 West Street, Durban.

Dated at Durban this 22nd day of September 1987.

Woodroffe & Kleyn, Plaintiff's Attorneys, 1st Floor, Masonic Grove Chambers, 32 Masonic Grove, Durban, 4001.

IN THE MAGISTRATE'S COURT FOR THE DISTRICT OF DURBAN HELD AT DURBAN

In the matter between **The New Republic Bank Limited**, Plaintiff, and **Y. B. Balraj**, Defendant

In pursuance of a Judgment granted on the 27th February 1986 in the above Court and under a Writ of Execution issued thereafter, the immovable property described hereunder shall be sold in execution on the 20th day of November 1987 by the Messenger of Court, at the Magistrate's Court, Mountview Shopping Centre, Verulam at 10.00 a.m., to the highest bidder.

Property: Lot 83, Everest Heights Township.

Postal address: 8 Kamet Crescent, Everest Height Township, Verulam.

Improvements: Brick and tile dwelling comprising of 3 bedroom, 1 kitchen, 1 lounge, 1 diningroom, 1 toilet, 1 bathroom.

Material conditions:

1. The sale shall be subject to the terms and conditions of the Magistrate's Court Act and the rules made hereunder.

2. The sale is for cash only.

3. The property is sold "voetstoots".

Dated at Durban this 21st day of September 1987.

Harkoo, Brijlal & Reddy, Plaintiff's Attorneys, 602 Kara Centre, 3 Bond Street, Durban. Ref.: Mr Reddy/N28/VP. Tel.: 3017772/3.

IN THE SUPREME COURT OF SOUTH AFRICA

(Durban and Coast Local Division)

In the matter between **Industrial Council For The Building Industry, Natal**, Plaintiff, and **Daltile**, Defendant

In execution of a Judgment of the Supreme Court of South Africa, Durban and Coast Local Division in the above suit, a sale to the highest bidder subject to a reserve price of seventy-one thousand three hundred and fifty-two rand and seventeen cents (R71 352,17) plus interest thereon at the rate of 16,5 % per annum from 16th September, 1987 to date of payment, both days inclusive, will be held on the steps of the Supreme Court, Masonic Grove, Durban, Natal on Friday the 30th day of October, 1987 at 10.00 a.m., of the undermentioned property on the conditions to be read out by the Auctioneer immediately prior to the sale and which conditions may be inspected at the office of the Deputy Sheriff, 1103 Sanlam Centre, 331 West Street, Durban:

Sub A of Sub 12 of Lot MM of the farm Duikerfontein 785, situate in the City of Durban, Administrative District of Natal, in extent one thousand and forty eight (1 048) square metres, and known as 10 Ben Nevis Road, Red Hill, Durban, being Special Residential and Coloured Zoning and which property is registered in the names of Dalton Vernon Bouchier and Lorraine Georgina Olga Bouchier.

The following information is furnished although nothing in this respect is guaranteed:

Single storey dwelling of brick and plaster under asbestos roof consisting of enclosed front porch, five rooms, kitchen and pantry, one bathroom and toilet combined. A flat adjoins the main building consisting of three rooms, kitchen, bathroom and toilet combined. Outbuildings of brick under tile roof consist of one double garage.

Terms: Ten per centum (10%) of the Purchase Price on the day of the sale, together with Auctioneer's Commission of five per centum (5%) of the purchase price up to an amount of ten thousand rand (R10 000) and thereafter two-and-one-half per centum (2½%) on the balance of the purchase price with a maximum of five thousand rand (R5 000) and subject to a minimum fee of twenty rand (R20). The balance of the Purchase Price against transfer of the property to be secured by an acceptable Bank or Building Society guarantee to be furnished to the Deputy Sheriff within seven (7) days after the date of the sale.

Lyle, Lambert & Knipe, Plaintiff's Attorneys, 17th Floor, General Building, 47 Field Street, Durban.

Case 2666/87

IN THE SUPREME COURT OF SOUTH AFRICA

(Durban and Coast Local Division)

In the matter between **Barclays National Bank Limited**, Plaintiff, and **William Arthur Azor**, Defendant

In the execution of a Judgment granted in the Supreme Court of South Africa, Durban and Coast Local Division, on the 11th June, 1987, in the abovementioned suit, the following property will be sold by the Deputy Sheriff of the Supreme Court, District of Durban, on the 30th October, 1987, at 10.00 a.m., on the steps of the Supreme Court, Masonic Grove, Durban, without reserve, on conditions to be read out by the Deputy Sheriff prior to the sale, which conditions may be inspected at the office of the Deputy Sheriff, 1103 Sanlam Centre, 331 West Street, Durban: Subdivision 1 of Lot E of 15 Block F of the Townlands of Durban 1737, situate in the City of Durban, Administrative District of Natal, measuring six hundred and twenty three (623 square metres) (address: 42 Maze Road, Glenwood, Durban).

Improvements: Without constituting a warranty of any nature, the property has been improved by the erection thereon of the following:

1 double storey brick and plaster under tile dwelling comprising *downstairs* 1 front verandah, 1 back verandah, 1 lounge, 1 room, 1 kitchen, 1 toilet, 2 small storerooms and *upstairs* 4 bedrooms, 1 bathroom/toilet/shower cubicle; 1 brick and plaster under asbestos outbuilding comprising 1 garage, 1 laundry, 1 servants room, 1 bathroom, 1 storeroom; 1 car port under asbestos roof.

Zoning: Special residential.

Group Area: White.

Terms: 10 per cent of the purchase price in cash on the day of sale, the balance against transfer to be secured by a Bank or Building Society guarantee to be approved by the Plaintiff's Attorneys, to be furnished to the Deputy Sheriff within 14 days after the date of sale.

Smithers & Co., Plaintiff's Attorneys, 42 Overport Drive, Durban, 4001.

Case 4116/86

IN THE MAGISTRATE'S COURT FOR THE DISTRICT OF DURBAN HELD AT DURBAN

In the matter between **Ashok Patel**, Plaintiff, and **Soomayah Naidoo**, Defendant

In pursuance of a Judgment granted on the 13th August 1986 in the above Honourable Court, and under a Writ of Execution issued thereafter, the immovable property listed hereunder shall be sold in Execution to the highest bidder on the 27th October 1987 at 10.00 a.m., in front of the Magistrate's Court, Chatsworth.

Description: Lot 1738 Shallcross (Extension 1), situate in the Development Area of Shallcross, Administrative District of Natal, in extent 541 square metres.

Postal address: 28 Sinai Street, Shallcross, Durban.

Improvements: The property consists of 1 brick block under tile roof dwelling comprising of double garage, lounge, 3 bedrooms, kitchen, toilet and bathroom, 3 rooms, toilet and bathroom, 2 bedrooms, kitchen, toilet and bathroom, 1 room, kitchen, toilet and bathroom and 1 toilet.

Material conditions:

1. The sale shall be subject to the terms and conditions of the Magistrate's Court Act and the Rules made thereafter.
- 2.1 The purchaser shall pay a deposit of 10% (ten percent) of the purchase price and the Auctioneer's Commission in cash immediately after the sale and the balance against transfer to be secured by a Bank or Building Society guarantee to be approved by the Plaintiff's Attorneys to be furnished to the Messenger of Court within 14 (fourteen) days after the sale.
- 2.2 The purchaser shall be liable for payment of interest at the rate of 20% to the Plaintiff on the respective amount of the award in the plan of distribution from the date of sale to the date of transfer, both days inclusive.
3. Transfer shall be effected by the attorneys for the Plaintiff and the Purchaser shall pay all transfer costs, including arrear and current rates, sewerage, connection fees (if any), taxes and other charges necessary to effect transfer on request by the said Attorneys.
4. Inasmuch as the Defendant is a member of the Indian Group no bids will be accepted by or on behalf of a person who is not a member of such group unless such person exhibits to the Auctioneer at the sale a permit from the Minister concerned authorising him to acquire such property.

The full conditions of sale may be inspected at the office of the Messenger of Court.

Dated at Durban on this 30th day of September 1987.

Kiran Desai & Company, Suites 60/61, 6th Floor, Cnr House, 22 Cross Street, Durban. (Ref.: A. Makan/tr/K16).

Case 28447/86

IN THE MAGISTRATE'S COURT FOR THE DISTRICT OF DURBAN HELD AT DURBAN

In the matter between **Allied Building Society**, Plaintiff, and **Adlah Naidu**, Defendant

In pursuance of a Judgment granted on the 27th day of July, 1986, in the Court of the Magistrate, Durban and under a Writ of Execution issued thereafter, the immovable property listed hereunder shall be sold in execution to the highest bidder on the 27th day of October, 1987 at 10.00 a.m., in front of the Magistrate's Court Building, Chatsworth.

Description: Sub 1449 of the farm Mobeni 13538, situate in the City of Durban, Administrative District of Natal, in extent four hundred and sixty five (465) square metres.

Postal address: 6 Turtle Place, Mobeni Heights, Durban.

Improvements: 1 partly double storey brick under tile roof dwelling comprising of 3 bedrooms, lounge, diningroom, balcony, shower-room, separate wash closet, bathroom with wash closet, kitchen, 1 large basement comprising 2 sections: Section 1 comprising of lounge, bedroom, shower, wash closet plus basin, kitchen. Section 2 comprising of lounge, bedroom, kitchen, shower plus wash closet and basin.

Group Areas Act: Group entitled to purchase: Indian.

Town Planning Zoning: Special Residential (400 sq metres min Plot size).

Special Privileges: Nil.

Nothing is guaranteed in the above respects

1. The sale shall be subject to the terms and conditions of the Magistrate's Court Act and the Rules made thereunder.

2.1 The purchaser shall pay a deposit of 10% of the purchase price and the auctioneer's commission in cash immediately after the sale, and the balance against transfer to be secured by a Bank or Building Society guarantee to be furnished to the Messenger of the Court within fourteen days after the sale to be approved by the Plaintiff's Attorneys.

2.2 The purchaser shall be liable for payment of interest at the rate of 14,5% per annum to the Execution Creditor and to the bondholder/s at a prescribed rate of interest per annum on the respective amounts of the awards to the Execution Creditor and to the Bondholder/s in the Plan of Distribution from the date of sale to date of transfer.

3. Inasmuch as the Defendant is a member of the Indian Group, no bids will be accepted by or on behalf of a person who is not a member of such Group, unless such person exhibits to the auctioneer, at the sale, a permit authorising him to acquire such property which is in a proclaimed Indian Area.

4. Transfer shall be effected by the attorneys of the Plaintiff and the Purchaser shall pay all transfer dues, including transfer duty, current and any arrear rates, and other necessary charges to effect transfer upon request by the said attorneys.

The full conditions of sale may be inspected at the offices of the Messenger of the Court, Chatsworth, at 12 Oak Avenue, Kharwastan.

Dated at Durban this 15th day of September, 1987.

Romer Robinson & Catterall, Plaintiff's Attorneys, 7th Floor, Allied Building, Gardiner Street, Durban.

Case 20614/87

IN THE MAGISTRATE'S COURT FOR THE DISTRICT OF DURBAN HELD AT DURBAN

In the matter between **Allied Building Society**, Plaintiff, and **Ramammah Perumal**, Defendant

In pursuance of a Judgment granted on the 10th day of July, 1987, in the Court of the Magistrate, Durban and under a Writ of Execution issued thereafter, the immovable property listed hereunder shall be sold in execution to the highest bidder on the 27th day of October, 1987 at 10.00 a.m., in front of the Magistrate's Court Building, Chatsworth.

Description: Lot 507 Kharwastan, situate in the City of Durban, Administrative District of Natal, in extent one thousand four hundred and seventy nine (1 479) square metres.

Postal address: Lot 507, Erica Avenue, Kharwastan, Chatsworth, Durban.

Improvements: A vacant piece of land.

Group Areas Act: Group entitled to purchase: Indian.

Town Planning Zoning: Special residential (650 sq. metres).

Special privileges: Nil.

Nothing is guaranteed in the above respects.

1. The sale shall be subject to the terms and conditions of the Magistrate's Court Act and the Rules made thereunder.

2.1 The purchaser shall pay a deposit of 10% of the purchase price and the auctioneer's commission in cash immediately after the sale, and the balance against transfer to be secured by a Bank or Building Society guarantee to be furnished to the Messenger of the Court within fourteen days after the sale to be approved by the Plaintiff's Attorneys.

2.2 The purchaser shall be liable for payment of interest at the rate of 14,5% per annum to the Execution Creditor and to the bondholder/s at a prescribed rate of interest per annum on the respective amounts of the awards to the Execution Creditor and to the Bondholder/s in the Plan of Distribution from the date of sale to date of transfer.

3. Inasmuch as the Defendant is a member of the Indian Group, no bids will be accepted by or on behalf of a person who is not a member of such Group, unless such person exhibits to the auctioneer, at the sale, a permit authorising him to acquire such property which is in a proclaimed Indian Area.

4. Transfer shall be effected by the attorneys of the Plaintiff and the Purchaser shall pay all the transfer dues, including transfer duty, current and any arrear rates, and other necessary charges to effect transfer upon request by the said attorneys.

The full conditions of sale may be inspected at the offices of the Messenger of the Court, Chatsworth, at 12 Oak Avenue, Kharwastan.

Dated at Durban this 14th day of September, 1987.

Romer Robinson & Catterall, Plaintiff's Attorneys, 7th Floor, Allied Building, Gardiner Street, Durban.

Case 19069/86

IN THE MAGISTRATE'S COURT FOR THE DISTRICT OF DURBAN HELD AT DURBAN

In the matter between **Allied Building Society**, Plaintiff, and **Ganesh**, Defendant

In pursuance of a Judgment granted on the 22nd day of May, 1986, in the Court of the Magistrate, Durban and under a Writ of Execution issued thereafter, the immovable property listed hereunder shall be sold in execution to the highest bidder on the 27th day of October, 1987 at 10.00 a.m., in front of the Magistrate's Court Building, Chatsworth.

Description: Sub 291 of 2281 of the Farm Chat One 14542, situate in the City of Durban, Administrative District of Natal, in extent two hundred and nine (209) square metres.

Postal address: 109 Duneria Road, Croftdene, Chatsworth.

Improvements: 1 Semi detached double storey block under asbestos roof dwelling comprising of 2 bedrooms, 1 lounge, 1 kitchen, 1 toilet, 1 bathroom. Outbuilding comprising of 1 garage, 1 room, 1 kitchen, 1 toilet.

Group Areas Act: Group entitled to purchase: Indian.

Town Planning Zoning: Special Residential (180 sq. metres min plot size).

Special privileges: Nil.

Nothing is guaranteed in the above respects:

1. The sale shall be subject to the terms and conditions of the Magistrate's Court Act and the Rules made thereunder.

2.1 The purchaser shall pay a deposit of 10% of the purchase price and the auctioneer's commission in cash immediately after the sale, and the balance against transfer to be secured by a Bank or Building Society guarantee to be furnished to the Messenger of the Court within fourteen days after the sale to be approved by the Plaintiff's Attorneys.

2.2 The purchaser shall be liable for payment of interest at the rate of 14,5% per annum to the Execution Creditor and to the bondholder/s at a prescribed rate of interest per annum on the respective amounts of the awards to the Execution Creditor and to the Bondholder/s in the Plan of Distribution from the date of sale to date of transfer.

3. Inasmuch as the Defendant is a member of the Indian Group, no bids will be accepted by or on behalf of a person who is not a member of such Group, unless such person exhibits to the auctioneer, at the sale a permit authorising him to acquire such property which is in a proclaimed Indian Area.

4. Transfer shall be effected by the attorneys of the Plaintiff and the Purchaser shall pay all the transfer dues, including transfer duty, current and any arrear rates, and other necessary charges to effect transfer upon request by the said attorneys.

The full conditions of sale may be inspected at the offices of the Messenger of the Court, Chatsworth, at 12 Oak Avenue, Kharwastan.

Dated at Durban this 22nd day of September, 1987.

Romer Robinson & Catterall, Plaintiff's Attorneys, 7th Floor, Allied Building, Gardiner Street, Durban.

Case 48853/84

IN THE MAGISTRATE'S COURT FOR THE DISTRICT OF DURBAN HELD AT DURBAN

In the matter between **The Trust Bank of Africa Limited**, Plaintiff, and **Kenny Devraj Naicker**, Defendant

In pursuance of a Judgment granted on the 17th September, 1985 in the Court of the Magistrate, Durban and under a Writ of Execution issued thereafter, the immovable properties listed hereunder will be sold in execution on the 29th day of October, 1987 at 10h00 in the front of the Magistrate's Court, Somiseu Road, Durban to the highest bidder:

Description: ¼ share in and to Sub. 19 of the farm Klein Zeekoe Vallei 803, situate in the City and County of Durban, Province of Natal, in extent 8 609 m².

Postal address: 163 Kennedy Road, Clare Estate, Durban.

Improvements: Vacant land.

Town Planning Zoning: Residential.

Group Areas Act Group entitled to occupy: Indian.

Description: Sub. D of 1 of A of Lot 9 No. 1527, situate in the City of Durban, County of Victoria, Province of Natal, in extent 1 034 m².

Postal address: 11 Vijay Terrace, Greenwood Park, Durban.

Improvements: One brick and asbestos dwelling consisting: *Upstairs:* 3 Bedrooms, 1 diningroom, 1 lounge, 1 kitchen, 1 toilet, 1 bathroom, verandah. *Downstairs:* 2 Bedrooms, diningroom/lounge, 1 bathroom, 1 kitchen.

Town Planning Zoning: Residential.

Group Areas Act: Group entitled to occupy: Indian.

Description: Sub. 238 of the farm Sydenham 14101, situate in the City and County of Durban, Province of Natal, in extent 465 m².

Postal address: 11 Linum Place, Asherville, Durban.

Improvements: Brick and tile dwelling consisting of: *Upstairs:* 2 Bedrooms, 1 toilet, 1 bathroom. *Downstairs:* 3 Bedrooms, 1 lounge, 1 diningroom, 1 kitchen, 2 bathrooms, 1 separate toilet. Basement: 1 Servant's room, 1 toilet, 1 shower, outside temple, garage attached to main building.

Town Planning Zoning: Residential.

Group Areas Act Group entitled to occupy: Indian.

Nothing is guaranteed in these respects.

Material Conditions:

1. The sale shall be subject to the terms and conditions of the Magistrate's Court Act and the Rules made thereunder.
 2. The purchaser shall pay a deposit of 10% of the purchase price in cash at the time of the sale, the balance against transfer to be secured by a Bank or Building Society guarantee to be approved by the Plaintiff's Attorneys to be furnished to the Court Messenger within fourteen (14) days after the date of sale.
 3. The attention of all prospective purchasers is directed to the provisions of the Group Areas Act.
 4. If more than one property is to be sold, the properties may be purchased separately, unless this is precluded by the conditions of title or law.
- The full conditions may be inspected at the offices of the Messenger of the Court, 15 Milne Street, Durban or at our offices.
M. L. Greenberg, for Berkowitz Kinkel Cohen Wartski Greenberg, Plaintiff's Attorneys, 19th Floor, 88 Field Street, Durban.

Case 35979/85

IN THE MAGISTRATE'S COURT FOR THE DISTRICT OF DURBAN HELD AT DURBAN

In the matter between **S. Ethwar**, Plaintiff, and **Shane Jalpal**, trading as **Shane's Construction**, Defendant

In pursuance of a Judgment granted on the 3rd September 1985, in the Court of the Magistrate, Durban and under a Writ of Execution issued thereafter, the immovable property listed hereunder shall be sold in execution to the highest bidder on the 5th November 1987 at 10h00 in front of the Magistrate's Court, Durban.

Description: Sub. 11 of Klein Vallei 803, in extent 1 230 square metres.

Postal address: 125 Morewood Road, Clare Estate, Durban.

The property consists of double storey, main building brick and tile dwelling consisting of upstairs 3 bedrooms, lounge, 1 diningroom, 1 kitchen, 1 toilet, 1 en-suite, 1 bathroom, balcony.

Downstairs: 3 Bedrooms, 3 lounges, 3 bathrooms and toilets.

Outbuilding: Brick and tile dwelling consisting of double garage.

- 1.1 The sale shall be subject to the terms and conditions of the Magistrate's Court Act and the Rules made thereunder.
- 1.2 The property shall be sold as it stands i.e. voetstoots and subject to all conditions of the Title Deed.
- 1.3 The purchaser shall pay a deposit of 10% of the purchase price and the auctioneer's commission in cash immediately after the sale, and the balance against transfer to be secured by a Bank or Building Society guarantee to be furnished to the Messenger of the Court within fourteen (14) days after the sale to be approved by the Plaintiff's Attorneys.
- 2.2 The purchaser shall be liable for payment of interest at the rate of 15 % per annum to the Plaintiff on the amount of the award to the Plaintiff in the Plan of Distribution from the date of sale to date of transfer.

3. Inasmuch as the Defendant is a member of the Indian Group, no bids will be accepted by or on behalf of a person who is not a member of such group, unless such person exhibits to the Auctioneer a permit authorising him to acquire such property which is in a proclaimed Indian Area.

4. Transfer shall be effected by the Attorneys of the Plaintiff and the Purchaser shall pay all the transfer dues, including transfer duty, current and any arrear rates, and other necessary charges to effect transfer upon request by the said Attorneys.

The full conditions of the sale may be inspected at the offices of the Messengers of the Court, 15 Milne Street, Durban.

Dated at Durban this 24th day of September 1987.

P. R. Maharaj & Co., Plaintiff's Attorneys, Suite 1601, Nedbank House, 30 Albert Street, Durban. Ref.: SPM/RP/E 22.

Case 11375/85

IN THE MAGISTRATE'S COURT FOR THE DISTRICT OF DURBAN HELD AT DURBAN

In the matter between **The Trust Bank of Africa Limited**, Plaintiff, and **Eben Bartholomeus Boshoff**, Defendant

In terms of a Judgment of the above Honourable Court, dated 7th May 1985, a sale in execution will be held on Friday, 13th November 1987, at 10.00 a.m., in front of the Magistrate's Court Building, Somtseu Road, Durban when the following property will be sold to the highest bidder:

One half share in and to Lot 2577 Kingsburgh (Ext. 15) situate in the Borough of Kingsburgh and in the Amanzimtoti Regional Water Services Area, Administrative District of Natal, in extent 1 266 square metres.

Situate at: 9 Kingsburgh Court, Turner Street, Amanzimtoti.

Improvements: Brick and Tile dwelling comprising of 2 bedrooms, 1 lounge and diningroom combined, 1 kitchen, 1 bathroom and 1 toilet.

The property is zoned for ownership by members of the White Group.

1. The sale shall be subject to the terms and conditions of the Magistrate's Court Act and the Rules made thereunder.

2. The purchaser shall pay a deposit of 10% of the purchase price and the auctioneer's commission in cash immediately after the sale, and the balance against transfer to be secured by a Bank or Building Society guarantee, to be approved by the Plaintiff's Attorneys, and to be furnished to the Messenger of Court within 14 days after the sale.

3. Inasmuch as the Defendant is a member of the White Group, no goods will be accepted by or on behalf of any person who is not a member of such group, unless such person exhibits to the auctioneer at the sale a permit authorising him to acquire such property.

4. Transfer shall be effected by the Plaintiff's Attorneys and the Purchaser shall pay all the transfer costs, including transfer duty, current and any arrear rates, and other necessary charges to effect transfer upon request by the said attorneys.

5. The full conditions of sale may be inspected at the office of the Messenger of Court, 101 Lejaton Building, 40 St George's Street, Durban.

Dated at Durban this 23rd day of September 1987.

De Villiers, Evans & Petit, Plaintiff's Attorneys, 500 N.B.S. Building, 300 Smith Street, Durban. (Ref.: Mrs Varty) 5/9474/84.

Case 49596/86

IN THE MAGISTRATE'S COURT FOR THE DISTRICT OF DURBAN HELD AT DURBAN

In the matter between **Santambank Limited**, Plaintiff, and **Rosemary Jane Roeters van Lennep**, Defendant

In pursuance of a Judgment in the Court of the Magistrate of Durban against Rosemary Jan Roeters van Lennep and Writ of Execution, dated 27th March 1987, the immovable property listed hereunder will be sold in Execution on the 30th October 1987 at the front of the Magistrate's Court, Somtseu Road, Entrance at 10.30 a.m., to the highest bidder.

Lot 1887 Amanzimtoti Township (Extension 5) situate in the Borough of Amanzimtoti, County of Durban, Province of Natal, in extent one thousand one hundred and twenty two (1 122) square metres.

Postal address: 16 School Road, Athlone Park.

Improvements: 1 Brick under tile roof dwelling comprising of 2 lounges, 1 kitchen, 1 diningroom, 4 bedrooms, 1 bathroom and toilet, passage, lock-up garage, servant's room and toilet and swimming pool.

Material conditions:

1. The sale shall be subject to the terms and conditions of the Magistrate's Act and the Rules made thereunder.

2. The purchaser shall pay 10% of the purchase price immediately after the sale and within fourteen days supply the Messenger of the Court with a Bank or Building Society guarantee for the balance of the purchase price in terms acceptable to the Messenger of the Court.

3. The attention of the prospective purchasers is directed to the provisions of the Group Areas Act.

4. The full provisions may be inspected at our offices and/or at the offices of the Court Messenger, Durban South.

Dated at Durban this 22nd day of September 1987.

A. D. Millar & Kimber, Plaintiff's Attorneys, 1st Floor, Ulundi House, Gardiner Street, Durban.

Case 41074/86

IN THE MAGISTRATE'S COURT FOR THE DISTRICT OF DURBAN HELD AT DURBAN

In the matter between **Simco Investment Company**, Plaintiff, and **Ronald Kasaval**, Defendant

In execution of a Judgment of the Magistrate's Court for the District of Durban in the above action, a sale will be held in front of the Magistrate's Court, Chatsworth on the 27th October 1987 at 10h00 of the undermentioned property of the Defendant on the conditions to be read out by the auctioneer at the time of the sale and which conditions may be inspected at the offices of the Messenger of Court, Chatsworth prior to the sale:

Lot 136 Burlington Heights (Extension 1) situate in the Development Area of Shallcross. Administrative District of Natal in extent eight hundred and ninety (890) square metres together with a brick dwelling house consisting of three bedrooms, lounge, bathroom, toilet, kitchen and diningroom, all situate at 61 Midmar Road, Burlington Heights.

Terms:

Ten (10) per cent of the purchase price in cash on the day of the sale or secured to the satisfaction of the Messenger of Court, the balance against transfer to be secured by Bank or Building Society or other acceptable guarantee to be furnished to the Messenger of Court within seven (7) days of the date of sale or otherwise suitably secured to the satisfaction of the Messenger of Court.

Dated at Durban this 23rd day of September 1987.

R. K. W. Ramsay, for Martin Dubois & Partners, Plaintiff's Attorneys, 9th Floor Maritime House, Salmon Grove, Durban, 4001.

Case 16664/87

IN THE MAGISTRATE'S COURT FOR THE DISTRICT OF DURBAN HELD AT DURBAN

In the matter between **Appertain Investments (Pty) Ltd**, Plaintiff, and **Ruthensamy Moodley**, Defendant

In pursuance of a Judgment granted on the 9th day of June 1987, in the Court of the Magistrate, Durban and under a Writ of Execution issued thereafter, the immovable property listed hereunder shall be sold in execution to the highest bidder on 24 November 1987 at 10.00 a.m., in front of the Magistrate's Court Building, Chatsworth.

Description: Lot 369 of Sub. 77 Klaarwater No. 951, situate in the Development Area of Shallcross, Administrative District of Natal, in extent 1 610 (one thousand six hundred and ten) square metres.

Held: By the Execution Debtor under Deed of Transfer No. 23596/80.

Postal address: 77 Kies Place, Shallcross, Durban.

Improvements: Dwelling comprising of 3 bedrooms, 1 bedroom with en-suite, lounge, diningroom, kitchen, toilet, bathroom, outbuilding, double garage, 2 (two) rooms, toilet.

Group Areas Act Group entitled to purchase: Indian.

Town Planning Zoning: Special residential.

Special privileges: Nil.

Nothing is guaranteed in the above respects:

1. The sale shall be subject to the terms and conditions of the Magistrate's Court Act and the Rules made thereunder.

2.1 The purchaser shall pay a deposit of 10% of the purchase price and the auctioneer's commission in cash immediately after the sale, and the balance against transfer to be secured by a Bank or Building Society guarantee to be furnished to the Messenger of the Court within 14 (fourteen) days after the sale to be approved by the Plaintiff's Attorneys.

2.2 The purchaser shall be liable for payment of interest at the rate of 14,5% per annum to the Execution Creditor and to the bondholder/s at a prescribed rate of interest per annum on the respective amounts of the awards to the Execution Creditor and to the bondholder/s in the Plan of Distribution from the date of sale to date of transfer.

3. Inasmuch as the Defendant is a member of the Indian Group, no bids will be accepted by or on behalf of a person who is not a member of such group, unless such person exhibits to the auctioneer, at the sale, a permit authorising him to acquire such property which is in a proclaimed Indian Area.

4. Transfer shall be effected by the attorneys of the Plaintiff and the purchaser shall pay all the transfer dues, including transfer duty, current and any arrear rates, and other necessary charges to effect transfer upon request by the said attorneys.

Dated at Durban this 25th day of September 1987.

M. S. Omar & Associates, Plaintiff's Attorneys, 1603 Nedbank House, 30 Albert Street, Durban.

Case 14730/87

IN THE MAGISTRATE'S COURT FOR THE DISTRICT OF DURBAN HELD AT DURBAN

In the matter between **United Building Society Limited**, No. 86/04794/06, Execution Creditor, and **Peter Calverley**, Execution Debtor

In pursuance of a Judgment granted on 19th May 1987 in the Court of the Magistrate, Durban and under a Writ of Execution issued thereafter, the immovable property listed hereunder will be sold in execution on Thursday, 29th October 1987 at 10.00 a.m., in front of the Magistrate's Court, Somtseu Road, Durban to the highest bidder.

Description: (a) Section 31 as shown and more fully described on sectional plan 30/1986 in the building or buildings known as "Marbeg" of which the floor area, according to the said sectional plan, is fifty two (52) square metres in extent; and

(b) an undivided share in and to the common property in the land and building or buildings as shown and more fully described on the said sectional plan, apportioned to the said section in accordance with the participation quota of the said section;

Postal address: 62 Marbeg, 166 Victoria Embankment, Durban.

Improvements: 1 bedroom carpeted, 1 kitchen fitted with cupboards, 1 lounge carpeted, 1 bathroom/toilet—hot/cold water;

Town Planning—Zoning: General Residential 5; Special Privileges: Nil.

Group Area Act: Group entitled to occupy: White.

Nothing is guaranteed in these respects.

Material conditions:

1. The sale shall be subject to the terms and conditions of the Magistrate's Court Act and the Rules made thereunder.

2. The purchaser shall pay a deposit of 10% of the purchase price in cash or by a bank guaranteed cheque at the time of the sale, the balance against transfer to be secured by a Bank or Building Society guarantee to be approved by the Plaintiff's Attorneys to be furnished to the Court Messenger within fourteen (14) days after the date of sale.

3. The attention of all prospective purchasers is directed to the provisions of the Group Areas Act.

4. If more than one property is to be sold, the properties may be purchased separately, unless this is precluded by the conditions of title or law.

The full conditions may be inspected at the offices of the Messenger of the Court, Durban or at our offices.

C. M. Kenton, for Browne, Brodie & Co., Plaintiff's Attorneys, 12th Floor, United Building, 291 Smith Street, Durban, 4001.

Case 4236/87

IN THE MAGISTRATE'S COURT FOR THE DISTRICT OF INANDA HELD AT VERULAM

In the matter between **Allied Building Society**, Plaintiff, and **Nolan Jagadason**, Defendant

In pursuance of a Judgment granted on the 28th July 1987, in the Court of the Magistrate, Verulam, and under a Writ of Execution issued thereafter, the immovable property listed hereunder will be sold in execution on the 30th day of October, 1987 at 10.00 a.m., in front of the Magistrate's Court, Verulam to the highest bidder.

Description: A certain piece of land being:

Lot 642 Northcroft, situate in the City of Durban, Administrative District of Natal, in extent six hundred and seventy seven (677) square metres.

Postal address: 100/106 Avalen Crescent, Northcroft, Phoenix.

Improvements: Brick and tile double storey building, comprising 2 shops (1 empty and 1 trading as Northcroft Supermarket).

Nothing is guaranteed in the above respects.

Material conditions:

1. The sale shall be subject to the terms and conditions of the Magistrate's Court Act and the Rules made thereunder.

2. (a) The purchaser shall pay a deposit of ten per centum (10%) of the purchase price and the Auctioneer's commission in cash immediately after the sale and the balance against transfer to be secured by a Bank or Building Society guarantee to be approved by the Plaintiff's Attorneys to be furnished to the Messenger of the Court within fourteen (14) days after the sale;

(b) The purchaser shall be liable for payment of interest at the rate of fourteen comma five per centum (14,5%) per annum to the Plaintiff on the amount of the award to the Plaintiff in the plan of distribution from the date of sale to date of transfer, both days inclusive.

3. Transfer shall be effected by the Attorneys for the Plaintiff and the purchaser shall pay all transfer costs, including arrear and current rates, sewerage connection fees (if any), taxes and all other charges necessary to effect transfer on request by the said Attorneys.

4. Inasmuch as the Defendant is a member of the Indian Group, no bids will be accepted by or on behalf of a person who is not a member of such group unless such person exhibits to the Auctioneer at the sale a permit from the Minister concerned authorising him to acquire such property.

The full conditions of sale may be inspected at the office of the Messenger of the Court, Verulam, 2 Mountview Shopping Centre, Cnr. Inanda Road & Jacaranda Avenue, Verulam, or at our offices of Biebuyck & Company, 2nd Floor J.B.S. Building, 78 Field Street, Durban.

Dated at Durban this 7th day of September, 1987.

Biebuyck & Company, Plaintiff's Attorneys, 2nd Floor, J.B.S Building, 78 Field Street, Durban. Ref. Mr. Gardyne/GAL.811.

Case 6497/87

IN THE MAGISTRATE'S COURT FOR THE DISTRICT OF PINETOWN HELD AT PINETOWN

In the matter between **Natal Building Society Limited**, No. 87/01384/06, Plaintiff, and **Gary John Clough**, Defendant

In pursuance of a Judgment granted on the 17th day of August 1987 in the above Court, and a Writ of Execution issued thereafter, the immovable property listed hereunder shall be sold in execution to the highest bidder on the 6th day of November 1987 at 10.00 a.m., in front of the Magistrate's Court, Pinetown:

The property is a brick under tile dwelling, and consists of one lounge and diningroom, one kitchen, three bedrooms, one bathroom, one toilet and one garage.

Described as: Lot 5698 Pinetown (Extension 58), situate in the Borough of Pinetown, and in the Pinetown Regional Water Services Area, Administrative District of Natal, in extent nine hundred and two (902) square metres.

Situate at: 14 Acacia Road, Caversham Glen.

1. The sale shall be subject to the terms and conditions of the Magistrate's Court Act and the Rules made thereunder.

2. The full conditions of sale may be inspected at the office of the Messenger of the Court, Pinetown, or at our offices.

3. The purchaser shall pay a deposit of ten per centum (10%) of the purchase price in cash at the time of the sale, the balance against transfer to be secured by a Bank or Building Society guarantee to be approved by us and to be furnished to the Court Messenger within fourteen (14) days after the date of sale.

4. The purchaser shall be liable for the payment of interest to the Plaintiff and to the bondholders at the prescribed rates of the respective amounts of the bonds.

5. Inasmuch as the Defendant is a member of the White Group, no bids will be accepted by or on behalf of a person who is not a member of such Group, unless such person exhibits to the auctioneer at the sale a permit from the Minister concerned authorising him to acquire such property which is in a proclaimed White Area.

6. Transfer shall be effected by the attorneys for the Plaintiff and the Purchaser shall pay all transfer dues, including transfer duty, current rates and other necessary charges to effect transfer, upon request by the said attorneys.

7. Payment of the Messenger/Auctioneer's fees are four per centum (4%) which is payable in cash on the day of the sale.

8. Possession and occupation of the property shall, subject to the rights of existing tenants, pass to the Purchaser upon the sale being effected, from which date all benefits, risks and liability shall pass to the Purchaser.

9. The improvements on the property are as stated above but no guarantees are given in this regard.

Dated at Pinetown this 22nd day of September 1987.

King & Associates, Plaintiff's Attorneys, 4th Floor, NBS Centre, Hill Street, Pinetown. Ref.: Mr Jenkins/N25.

Case 23789/87

IN THE MAGISTRATE'S COURT FOR THE DISTRICT OF DURBAN HELD AT DURBAN

In the matter between **Allied Building Society**, Plaintiff, and **Daya Appalsamy Naidoo**, Defendant

In pursuance of a Judgment granted on the 22nd day of July, 1987, in the Court of the Magistrate, Durban and under a Writ of Execution issued thereafter, the immovable property listed hereunder shall be sold in execution to the highest bidder on the 27th day of October, 1987 at 10.00 a.m., in front of the Magistrate's Court Building, Chatsworth.

Description: Sub 1283 (of 1229) of Lot Crossmoor 15061, situate in the City of Durban, Administrative District of Natal, in extent three hundred and forty one (341) square metres.

Postal address: House 73, Road 1126, Chatsworth, Durban.

Improvements: 1 double storey block under asbestos roof dwelling comprising of 3 bedrooms, 1 lounge, 1 diningroom, kitchen, toilet downstairs, 1 bathroom upstairs, 1 bath, basin and wash closet upstairs, verandah.

Group Areas Act: Group entitled to purchase: Indian.

Town Planning Zoning: Special Residential (180 sq. metres).

Special privileges: Nil.

Nothing is guaranteed in the above respects.

1. The sale shall be subject to the terms and conditions of the Magistrate's Court Act and the Rules made thereunder.

2.1 The purchaser shall pay a deposit of 10% of the purchase price and the auctioneer's commission in cash immediately after the sale, and the balance against transfer to be secured by a Bank or Building Society guarantee to be furnished to the Messenger of the Court within fourteen days after the sale to be approved by the Plaintiff's Attorneys.

2.2 The purchaser shall be liable for payment of interest at the rate of 14,5% per annum to the Execution Creditor and to the bondholder/s at a prescribed rate of interest per annum on the respective amounts of the awards to the Execution Creditor and to the Bondholder/s in the Plan of Distribution from the date of sale to date of transfer.

3. Inasmuch as the Defendant is a member of the Indian Group, no bids will be accepted by or on behalf of a person who is not a member of such Group, unless such person exhibits to the auctioneer, at the sale, a permit authorising him to acquire such property which is in a proclaimed Indian Area.

4. Transfer shall be effected by the attorneys of the Plaintiff and the Purchaser shall pay all the transfer dues, including transfer duty, current and any arrear rates, and other necessary charges to effect transfer upon request by the said attorneys.

The full conditions of sale may be inspected at the offices of the Messenger of the Court, Chatsworth, at 12 Oak Avenue, Kharwastan.

Dated at Durban this 14th day of September, 1987.

Romer Robinson & Caterall, Plaintiff's Attorneys, 7th Floor, Allied Building, Gardiner Street, Durban.

Case 7815/86

IN THE MAGISTRATE'S COURT FOR THE DISTRICT OF INANDA HELD AT VERULAM

In the matter between **Tongaat Town Board**, Plaintiff, and **Kalapathy**, in her capacity as Executrix in the State of the late Rampersad, Defendant

In pursuance of a Judgment in the Court of the Magistrate of Verulam and Warrant of Execution date 31st March 1987, the immovable property listed hereunder will be sold on the 6th day of November 1987 at 11.00 a.m., in front of the Magistrate's Court, Moss Street, Verulam to the highest bidder:

Description: Sub 2 of Lot 315 Tongaat.

Postal address: 32 Walter Reid Road, Maidstone, opposite David Whitehead.

Improvements: Brick under asbestos dwelling comprising 4 bedrooms, 1 kitchen, 1 lounge, 1 bathroom and 1 toilet (old house with broken windows and doors).

Material Conditions:

1. The sale shall be subject to the terms and conditions of the Magistrate's Court Act, and the Rules made thereunder.
2. The purchaser shall pay 10% of the purchase price immediately after the sale and the balance against registration of the transfer into the name of the Purchaser.

3. The attention of prospective Purchasers is directed to the Provisions of the Group Act.

The full conditions of the sale may be inspected at our offices and/or at the Offices of the Messenger of Court, Verulam.

Dated at Tongaat this 23rd day of September 1987.

Omprakash Ramlakhan, for Omprakash Ramlakhan & Company, Plaintiff's Attorneys, Suite 7, Foresum Centre, 314 Main Road, Tongaat, 4400, c/o 182c Wick Street, Verulam. PM/sb/855/86.

Case 5744/86

IN THE MAGISTRATE'S COURT FOR THE DISTRICT OF CHATSWORTH HELD AT CHATSWORTH

In the matter between **Santambank Limited**, Plaintiff, and **Yassen Osman Shalk**, Defendant

In pursuance of a Judgment granted on the 2nd April 1987 in the Court of the Magistrate, Chatsworth, and under a Writ of Execution issued thereafter, the immovable property listed hereunder shall be sold in execution to the highest bidder on the 5th November 1987, at 10.00 a.m., at the entrance to the Magistrate's Court Building, Somtseu Road, Durban.

Description: Sub. 3 of Lot 189 Kenville, situate in the City of Durban, Administrative District of Natal, in extent 725 square metres.

Postal address: 198 Rosary Road, Kenville.

1. The sale shall be subject to the terms and conditions of the Magistrate's Court Act and the Rule made thereunder.
- 2 (a) The purchaser, shall pay a deposit of 10% of the purchase price in cash immediately after the sale and the balance against transfer to be secured by a Bank or Building Society guarantee to be furnished to the Messenger of Court within fourteen (14) days after the sale, to be approved by the Plaintiff's Attorneys.

(b) The purchaser shall be liable for the payment of interest at the rate of twenty one (21) % to the Plaintiff and at the prescribed rate of interest to the bondholders on the respective amount of the awards in the Plan of Distribution from the date of sale to the date of transfer, both days inclusive.

3. Inasmuch as the defendant is a member of the Indian Group, no bids will be accepted by or on behalf of a person who is not a member of the Indian Group, unless such person exhibits to the Auctioneer at the sale a permit from the Minister concerned authorising him to acquire such property which is in a proclaimed Indian Area.

4. Transfer shall be effected by the Attorneys for the Plaintiff and the Purchaser shall pay all transfer dues, including transfer duty, current rates and other necessary charges to effect transfer upon request by the said attorneys.

The full conditions of sale may be inspected at the offices of the Messenger of Court, Somtseu Road, Durban.

Dated at Chatsworth this 23rd day of September 1987.

P. Ramjathan, for Moola & Singh, Plaintiff's Attorneys, 1st Floor, Aboo's Building, 270 Road 201, Chatsworth. Ref.: Mr Valodia 3788/27.

Case 7191/86

IN THE SUPREME COURT OF SOUTH AFRICA

(Durban and Coast Local Division)

In the matter between **Wilhelm Johannes Pieterse**, Plaintiff, and **Lazarus Job**, 1st Defendant; **Pravesh Koblall**, 2nd Defendant

In pursuance of a Judgment in the Supreme Court of South Africa, dated the 15th January 1987 and a Warrant of Execution dated the 24th June 1987, the property situate at Lot 23 Krishnapuri, situate in the Township of Tongaat, Administrative District of Natal in extent 102 m² will be sold by the Deputy Sheriff of Verulam in front of the Magistrate's Court, Verulam on the 30th day of October 1987 at 10.00 a.m., to the highest bidder with a reserve price of R65 095, plus interest at 14% from the 31st October 1987 to date of settlement.

Street Address: 4 Krishnapuri Road, Tongaat, and held by the 1st Defendant under Deed of Transfer No. T1503/77 dated the 4/2/77.

No Special terms or exemptions other than those stated are believed to exist:

1. The sale shall be on the terms and conditions to be read out by the auctioneer, which terms and conditions may be inspected at the offices of the Deputy Sheriff, Verulam, Natal, prior to the sale and all interested persons are advised to become fully acquainted therewith and with the property, before the sale;

2. the sale shall be subject to the provisions of the Supreme Court Act 59 of 1959 and the Rules thereto;

3. the successful bidder is required to pay the deposit of 10% of the price, plus the sheriff's charges, in cash or by Bank or Bank guaranteed cheque or Bank letter of authority on conclusion of the sale.

4. The transfer shall be effected by the Plaintiff's Attorneys and the Purchaser shall pay all the transfer dues, including transfer duty, current and any arrear rates, and other necessary charges to effect transfer upon request by the said attorneys;

5. Inasmuch as the Defendant is a member of the Indian Group, no bids will be accepted by or on behalf of a person who is not a member of such Group, unless such person exhibits to the Auctioneer a permit authorising him to acquire such property which is in a proclaimed Indian Area.

Dated at Durban this the 6th day of October 1987.

D. K. Merret, for D. K. Merret Associates, Plaintiff's Attorneys, 152 Essenwood Road, Durban. D. K. Merret.

Case 23232/86

IN THE MAGISTRATE'S COURT FOR THE DISTRICT OF PINETOWN HELD AT PINETOWN

In the matter between **Ahmed Kajee**, Plaintiff, and **Ahmed Gora Essop Essack**, First Defendant; **Farida Essack**, Second Defendant

In pursuance of a Judgment granted on the 6th November 1986 in respect of Case 23232/86 in the Magistrate's Court, Durban, and under a Writ of Execution issued thereafter, the immovable property listed hereunder shall be sold in execution to the highest bidder on the 30th day of October 1987 at 10.00 a.m., at the front entrance of the Magistrate's Court, Chancery Lane, Pinetown.

Description: Lot 3377 Reservoir Hills (Extension 15), situate in the City of Durban, Administrative District of Natal, in extent 1 144 square metres.

Postal address: Annet Drive, Reservoir Hills.

Conditions: Include Clauses:

1. The sale shall be subject to the terms and conditions of the Magistrate's Court Rule Act and the Rules made thereunder.

7.1 The purchaser shall, in addition to auctioneer's charges, pay a deposit of 10% of the purchase price in cash at the time of the sale, the balance against transfer to be secured by a Bank or Building Society guarantee, to be approved by the Execution Creditor's Attorney, to be furnished to the Deputy Sheriff within fourteen (14) days after the date of sale.

7.2 The purchaser shall be liable for payment of interest to the Execution Creditor at the rate of 20% p.a. and to the bondholder at the rate of 20% p.a., on the respective amounts of the award to the Plaintiff and the bondholder in the plan of distribution as from the date of sale to date of transfer.

8. Inasmuch as the Execution Debtor is a member of the Asian Group, no bids will be accepted by or on behalf of a person who is not a member of such Group, unless such person exhibits to the auctioneer immediately prior to the sale, a permit from the Minister concerned authorising him to acquire such property.

10. The purchaser shall pay auctioneer's charges on the day of sale and in addition, transfer dues, costs of transfer and arrear rates, taxes and other charges necessary to effect transfer, upon request by the attorneys for the execution creditor.

The full conditions of sale may be inspected at the offices of the Messenger of Court, Pinetown.

Dated at Durban 6th October 1987.

Chetwynd-Palmer and Partners, Plaintiff's Attorneys, 1207 Sanlam Musgrave Centre, Musgrave Road, Durban. (Ref.: PGD de Broglio/rid).

ORANJE-VRYSTAAT • ORANGE FREE STATE

Saak 2996/87

IN DIE LANDDROSHOF VIR DIE DISTRIK VAN ODENDAALSRUS GEHOU TE ODENDAALSRUS

In die saak tussen: **Allied Bouvereniging Beperk**, Eiser, en **Jacobus Louls Lombaard**, Eerste Verweerder en **June Dawn Lombaard**, Tweede Verweerderes

Ingevolge 'n Vonnis en 'n Lasbrief vir Eksekusie gedateer die 17de dag van September 1987 in die Landdroshof te Odendaalsrus sal die volgende eiendom verkoop word op Saterdag, 24 Oktober 1987 om 10h00 te die Landdroskantoor, Odendaalsrus.

Sekere Erf No. 1289 (Ross Kent).

Geleë te die Dorpsgebied van Odendaalsrus, distrik Odendaalsrus.

Groot 644 (Ses Vier Vier) Vierkante Meter.

Onderhewig aan sekere Serwitute en gehou kragtens Akte van Transport No. 7830/1986 geregistreer op 25ste September 1986.

Met verbeterings daarop naamlik: Woonhuis met dubbel motorhuis, sitkamer, eetkamer, kombuis, opwaskamer, drie slaapkamers, badkamer/toilet, badkamer/toilet/stort, buite bediende toilet.

Voorwaardes van Verkoop:

1. Die eiendom sal voetstoots en sonder reserwe verkoop word aan die hoogste bieder onderhewig aan die bepalinge van die Wet op Landdroshowe No. 32 van 1944 soos gewysig, en die Reëls daarkragtens uitgevaardig.

2. Die Koopprijs sal as volg betaalbaar wees:

'n Deposito van Tien Persent (10%) van die Koopprijs in kontant onmiddellik na afhandeling van die veiling en die onbetaalde balans tesame met rente daarop bereken teen 14,5% per jaar tot datum van registrasie van Transport sal binne 14 (Veertien) dae betaal word of gewaarborg word deur 'n goedgekeurde Bank- of Bougenootskap waarborg.

3. *Voorwaardes*

Die volle verkoopvoorwaardes wat deur die Afslaer uitgelees sal word onmiddellik voor die verkoping kan gedurende kantoorure by die kantoor van die Geregsbode, Odendaalsrus nagesien word.

Gedateer te Odendaalsrus hierdie 17de dag van September 1987.

Grunow Frost & Viljoen, Prokureurs vir Eiser, Viljoengebou, Odendaalstraat 51, Posbus 170, Odendaalsrus, 9480. Tel: 4-1244/5.

IN DIE LANDDROSHOF VIR DIE DISTRIK VAN ODENDAALSUS GEHOU TE ODENDAALSUS

In die saak tussen: **Allied Bouvereniging Beperk**, Eiser, en **Hendrik Frederik Welman**, Eerste Verweerder en **Helena Johanna Elizabeth Welman**, Tweede Verweerderes

Ingevolge 'n Vonnis en 'n Lasbrief vir Eksekusie gedateer die 2de dag van September 1987 in die Landdroshof te Odendaalsrus sal die volgende eiendom verkoop word op Saterdag, 24 Oktober 1987 om 10h00 te die Landdroskantoor, Odendaalsrus.

Sekere Erf No. 384.

Geleë te die Dorpsgebied van Odendaalsrus, distrik Odendaalsrus.

Groot 773 (Sewe Sewe Drie) Vierkante Meter.

Onderhewig aan sekere Serwitute en gehou kragtens Akte van Transport No. 12170/1979 geregistreer op 28 Desember 1979.

Met verbeterings daarop naamlik: Woonhuis bestaande uit sit/eetkamer; hoofslaapkamer met privaat badkamer/toilet; Drie ander slaapkamers; ingeboude kaste in alle kamers; aparte toilet en badkamer; kombuis; Buitegebou: Dubbele motorhuis; bediende kamer met toilet; swembad—Erf met beton omhein.

Voorwaardes van Verkoop:

1. Die eiendom sal voetstoots en sonder reserwe verkoop word aan die hoogste bieder onderhewig aan die bepalings van die Wet op Landdroshowe No. 32 van 1944 soos gewysig, en die Reëls daarkragtens uitgevaardig.

2. Die Koopprijs sal as volg betaalbaar wees:

'n Deposito van Tien Persent (10%) van die Koopprijs in kontant onmiddellik na afhandeling van die veiling en die onbetaalde balans tesame met rente daarop bereken teen 14,5% per jaar tot datum van registrasie van Transport sal binne 14 (Veertien) dae betaal word of gewaarborg word deur 'n goedgekeurde Bank- of Bougenootskap waarborg.

3. *Voorwaardes*

Die volle verkoopsvoorwaardes wat deur die Afslaer uitgelees sal word onmiddellik voor die verkoping kan gedurende kantoorure by die kantoor van die Geregsbode, Odendaalsrus nagesien word.

Gedateer te Odendaalsrus hierdie 14de dag van September 1987.

Grunow Frost & Viljoen, Prokureurs vir Eiser, Viljoengebou, Odendaalstraat 51, Posbus 170, Odendaalsrus, 9480. Tel: 4-1244/5.

Saak 5119/87

IN DIE LANDDROSHOF VIR DIE DISTRIK VAN BLOEMFONTEIN GEHOU TE BLOEMFONTEIN

In die saak tussen: **Die Stadsraad van die Munisipaliteit van Bloemfontein**, Eiser, en **F. J. Pretorius**, Verweerder

Ingevolge 'n uitspraak in die Hof van die Landdros van Bloemfontein en 'n Lasbrief vir Geregtelike Verkoop gedateer 27 Augustus 1987 sal die volgende eiendom op Vrydag 20 November 1987 om 10h00 by die Peetlaan Ingang van die Landdroshof, Bloemfontein aan die hoogste bieder geregtelik verkoop word:

Sekere Erf No. 3203 geleë in die stad en distrik Bloemfontein.

Groot 733 Vierkante Meter;

Gehou kragtens Akte van Transport No. 9387/85 geregistreer op 27/11/85.

(Perseeladres is Monumentweg 5, Oranjesig, Bloemfontein.)

Die volgende verbeterings is aangebring maar niks word gewaarborg nie: *Woonhuis* bestaande uit 3-slaapkamers, 1 Kombuis, 1 Badkamer met Toilet, 1 Sitkamer, 1 Eetkamer. *Buitegeboue* bestaande uit 'n buite toilet.

Die verkoopsvoorwaardes lê ter insae by die kantoor van die Geregsbode, Barnesstraat 5, Bloemfontein.

Geteken te Bloemfontein hierdie 29ste dag van September 1987.

J. P. de Wet, p/a Naudes, Prokureur vir Eiser, 3de Vloer, Trustfonteingebo, Posbus 260, St Andrewstraat 151, Bloemfontein.

Saak 10215/87

IN DIE LANDDROSHOF VIR DIE DISTRIK VAN BLOEMFONTEIN GEHOU TE BLOEMFONTEIN

In die saak tussen: **Die Stadsraad van die Munisipaliteit van Bloemfontein**, Eiser, en **J. D. Pretorius**, Verweerder

Ingevolge 'n uitspraak in die Hof van die Landdros van Bloemfontein en 'n Lasbrief vir Geregtelike Verkoop gedateer 26 Augustus 1987 sal die volgende eiendom op Vrydag 20 November 1987 om 10h00 by die Peetlaan Ingang van die Landdroshof, Bloemfontein aan die hoogste bieder geregtelik verkoop word:

Sekere Erf No. 6869 geleë in die stad en distrik Bloemfontein.

Groot 1174 Vierkante Meter;

Gehou kragtens Akte van Transport No. 5269/83 geregistreer op 3/6/83.

(Perseeladres—Roderick Singel 20, Noordhoek, Bloemfontein.)

Die volgende verbeterings is aangebring maar niks word gewaarborg nie: *Woonhuis bestaande uit*: Sitkamer, Eetkamer, TV-kamer, Kombuis, 4-slaapkamers, 2-badkamers stort, stoep, swembad. *Buitegeboue* Twee motorhuise, buite latrine.

Die verkoopsvoorwaardes lê ter insae by die kantoor van die Geregsbode, Barnesstraat 5, Bloemfontein.

Geteken te Bloemfontein hierdie 30ste dag van September 1987.

J. P. de Wet, p/a Naudes, Prokureur vir Eiser, 3de Vloer, Trustfonteingebo, Posbus 260, St Andrewstraat 151, Bloemfontein.

IN DIE LANDDROSHOF VIR DIE DISTRIK VAN BLOEMFONTEIN GEHOU TE BLOEMFONTEIN

In die saak tussen: **Plaaslike Raad Bloemspruit**, Eiser, en **P. J. van Wyk—1300190010**, Verweerder

Geliewe Kennis Te Neem dat ter uitvoering van die vonnis gegee deur die Landdros te Bloemfontein en gedateer 17 Junie 1986 die onderstaande onroerende eiendom te die Landdroshof, Peetlaan ingang, Bloemfontein op Vrydag, 6 November 1987 per publieke veiling aan die hoogste bieder verkoop sal word, naamlik:

Sekere Plot No. 19 Fairview kleinplase geleë in die Plaaslike Gebied Bloemspruit distrik Bloemfontein.

Groot 4,2827 hektaar.

Geliewe Voorts Kennis te neem dat die verkoopsvoorwaardes by die Geregsbode se kantore vir insae lê.

Geteken te Bloemfontein hierdie 30ste dag van September 1987.

L. Vermaak, p/a Vermaak & Dennis, Prokureur vir Eiser, Voortrekkerstraat 96, Bloemfontein.

Aan: Die Klerk van die Hof, Bloemfontein.

En Aan: Die Geregsbode, Bloemfontein.

Saak 1977/86

IN DIE LANDDROSHOF VIR DIE DISTRIK VAN BLOEMFONTEIN GEHOU TE BLOEMFONTEIN

In die saak tussen: **Plaaslike Raad Bloemspruit**, Eiser, en **F. A. Mynhardt—1660620010**, Verweerder

Geliewe Kennis Te Neem dat ter uitvoering van die vonnis gegee deur die Landdros te Bloemfontein en gedateer 11 Maart 1986 die onderstaande onroerende eiendom te die Landdroshof, Peetlaan ingang, Bloemfontein op Vrydag, 6 November 1987 per publieke veiling aan die hoogste bieder verkoop sal word, naamlik:

Sekere Plot No. 62, synde 'n gedeelte van die gedeelte bekend as Rodenbeck "C" No. 2479 van die plaas Rodenbeck No. 834, geleë in die distrik Bloemfontein.

Groot 4,2827 hektaar.

Geliewe Voorts Kennis te neem dat die verkoopsvoorwaardes by die Geregsbode se kantore vir insae lê.

Geteken te Bloemfontein hierdie 29ste dag van September 1987.

L. Vermaak, p/a Vermaak & Dennis, Prokureur vir Eiser, Voortrekkerstraat 96, Bloemfontein.

Aan: Die Klerk van die Hof, Bloemfontein.

En Aan: Die Geregsbode, Bloemfontein.

Saak 1035/86

IN DIE LANDDROSHOF VIR DIE DISTRIK VAN BLOEMFONTEIN GEHOU TE BLOEMFONTEIN

In die saak tussen: **Plaaslike Raad Bloemspruit**, Eiser, en **J. J. van Huyssteen—1011710016**, Verweerder

Geliewe Kennis Te Neem dat ter uitvoering van die vonnis gegee deur die Landdros te Bloemfontein en gedateer 10 Februarie 1986 die onderstaande onroerende eiendom te die Landdroshof, Peetlaan ingang, Bloemfontein op Vrydag, 6 November 1987 per publieke veiling aan die hoogste bieder verkoop sal word, naamlik:

Sekere Plot No. 171, 'n gedeelte van die gedeelte bekend as Bloemspruit "C" No. 332, van die plaas Bloemspruit "A" No. 2144 geleë in die plaaslike gebied van Bloemspruit, distrik Bloemfontein.

Groot 4,3712 hektaar.

Geliewe Voorts Kennis te neem dat die verkoopsvoorwaardes by die Geregsbode se kantore vir insae lê.

Geteken te Bloemfontein hierdie 30ste dag van September 1987.

L. Vermaak, p/a Vermaak & Dennis, Prokureur vir Eiser, Voortrekkerstraat 96, Bloemfontein.

Aan: Die Klerk van die Hof, Bloemfontein.

En Aan: Die Geregsbode, Bloemfontein.

Saak 5364/86

IN DIE LANDDROSHOF VIR DIE DISTRIK NEWCASTLE GEHOU TE NEWCASTLE

In die saak tussen: **Vrystaat Ko-op Beperk**, Eiser, en **Anton Christiaan Frederick Badenhorst**, Verweerder

Geliewe Kennis Te Neem Dat Die Ondervermelde Eiendom by wyse van Openbare veiling verkoop sal word deur die Geregsbode vir die distrik Bethlehem op Vrydag, 23 Oktober 1987 om 11.00vm voor die Landdroskantoor, Bethlehem, naamlik:

Een Onverdeelde Halfdeel van Erf No. 1531, bekend as Whitestraat 23, Morelig, Bethlehem.

Die eiendom is verbeter met 'n woonhuis en buitegeboue.

Die Verkoopsvoorwaardes is by die kantore van die Geregsbode Bethlehem ter insae.

Gedateer te Newcastle op hierdie 1ste dag van September 1987.

A. I. Odendaal, vir Van Lingen van Wyk Odendaal & Fourie, Volkskasgebou, 2de Vloer, Voortrekkerstraat, Newcastle.

IN DIE LANDDROSHOF VIR DIE DISTRIK BOTHAVILLE GEHOU TE BOTHAVILLE

In die saak tussen: **Volkskas Beperk**, Eiser, en **H. Odendaal**, Verweerder

Geliewe kennis te neem dat die ondergemelde Vaste Eiendom sal per openbare veiling verkoop word aan die hoogste bieder en wel op 30 Oktober 1987 om 10h00 voor die Landdroskantore te Bothaville.

1. Die plaas bekend as Onderverdeling I (Presidentsvlei) van Holvlei No. 249, distrik Bothaville. Groot: 169,5933 hektaar.
2. Sekere gedeelte bekend as Klipkraal No. 54 van Doornkraal No. 229 distrik Bothaville. Groot: 340,899 hektaar.

Die verkoopsvoorwaardes sal ter insae lê by die Geregsbode Bothaville.

Geteken te Bothaville op 8 September 1987.

G. P. Nieuwoudt & Vennote, Prokureur vir Eiser, Bothaville.

E. J. P. Pieterse, Geregsbode.

Saak 3004/87

IN DIE LANDDROSHOF VIR DIE DISTRIK VAN KROONSTAD GEHOU TE KROONSTAD

In die saak tussen: **S A Permanente Bouvereniging**, Eksekusieskuldeiser, en **Mmolaoa David Tiadi**, Eksekusieskuldenaar

Ingevolge 'n vonnis van die Landdroshof, Kroonstad en 'n lasbrief vir eksekusie gedateer 3 Julie 1987 sal die volgende eiendom by wyse van openbare veiling in eksekusie verkoop word op Saterdag die 3 lste dag van Oktober 1987 om 09h00 voor die kantoor van die Geregsbode Kroonstad.

Erf No. 1508 geleë te Perseel 1508 Seeiosoville Dorpsgebied (Uitbreiding 1).

Groot 345 vierkante meter;

Gehou kragtens Sertifikaat van Geregisteerde Toekenning van Huurpag No. TL 888/86 gedateer 5 Junie 1986.

Verbeterings: Drie slaapkamer woonhuis met sitkamer, eetkamer, kombuis, badkamer met toilet en motorhuis.

Die eiendom is gesoneer vir woondoeleindes.

Voorwaardes van verkoping:

1. Die eiendom sal voetstoots verkoop word aan die hoogste bieder onderbewig aan die bepalinge van die Wet op Landdroshowe, No. 32 van 1944, soos gewysig en die reëls daarkragtens uitgevaardig.

2. Die koopprijs sal as volg betaalbaar wees:

'n Deposito van 10% (tien persent) van die koopprijs in kontant onmiddellik na afhandeling van die veiling en die onbetaalde balans tesame met rente daarop bereken teen 16,5% per jaar vanaf datum van verkoping tot datum van registrasie van transport sal binne 21 (een en twintig) dae betaal word of gewaarborg word deur 'n goedgekeurde Bank- of Bougenootskapwaarborg.

3. Die volle verkoopsvoorwaardes wat deur die afslaer uitgelees sal word onmiddellik voor die verkoping kan gedurende kantoorure by die kantoor van die geregsbode Kroonstad nagesien word.

Geteken te Welkom op hede die 16de dag van September 1987.

F. J. Kapp, vir Wessels & Smith, p/a De Hart, Steyn & Vennote, Brandstraat 30, Kroonstad.

Saak 94/87

IN DIE LANDDROSHOF VIR DIE DISTRIK LINDLEY GEHOU TE LINDLEY

In die saak tussen: **Allied Bouvereniging**, Eiser, en **Johannes Hendrik Lodewyk Gordon**, Verweerder

Ter uitvoering van 'n Vonnis van bogemelde Agbare Hof en 'n lasbrief tot Eksekusie, sal 'n verkoping van die volgende eiendom van die bogenoemde Verweerder voor die Landdroskantoor Lindley gehou word om 10h00 in die voormiddag op Woensdag, 28 Oktober 1987 naamlik:

Sekere Erf No. 290, geleë in die dorp Lindley, distrik Lindley;

Groot 1 487 Vierkante Meter;

Gehou kragtens Akte van Transport No. T474/1987;

Onderworpe aan sekere Serwitute.

Ter inligting word vermeld dat die verbeterings op die erf bestaan uit 'n woonhuis en buitegeboue geleë in 'n gebied gereserveer vir die Blanke Groep, maar niks word in hierdie opsig gewaarborg nie.

Die eiendom sal aan die hoogste bieder verkoop word onderbewig aan 'n minimum prys en die volledige Verkoopsvoorwaardes lê ter insae by die Kantoor van die Landdros te Lindley en die Kantoor van die Geregsbode te Lindley gedurende kantoorure.

Dateer te Bethlehem hierdie 5de dag van Oktober 1987.

Breytenbach, Van der Merwe & Botha, Prokureurs vir Eiser, Eerste Vloer, Sanlamgebu, Boshoffstraat, Posbus 693, Bethlehem.

Geregsbode, Bethlehem.

OPENBARE VEILINGS, VERKOPE EN TENDERS PUBLIC AUCTIONS, SALES AND TENDERS

TRANSVAAL

JOHNNIE'S AUCTIONEERING COMPANY

INSOLVENTE BOEDEL, KAREL JACOBUS MEYER, No. T 43/87

Behoorlik daartoe gelas deur die Kurator in bogemelde insolvente boedel word by wyse van openbare veiling op die perseel, Attiestraat 847, Booyens, Pretoria op Vrydag die 30ste Oktober 1987, om 10h00; die volgende verkoop:

Gedeelte 5 van Erf 45, Booyens, Registrasie Afdeling J.R., Transvaal;

Geleë te: Attiestraat 847, Booyens, waarop 'n woonhuis opgerig is wat bestaan uit:

- (1) Drie slaapkamers;
- (2) groot goed toegeruste kombuis;
- (3) sitkamer;
- (4) badkamer met aparte toilet;

waarop buitegeboue opgerig is wat bestaan uit:

- (1) Waskamer;
- (2) enkelmotorhuis;
- (3) bediendekamer en bediende toilet.

Terme: 20% deposito in kontant of bankgewaarborgde tjek, betaalbaar op ondertekening van die verkoopsvoorwaardes en die balans binne 30 (dertig) dae vanaf ondertekening van die verkoopsvoorwaardes.

Afslerswenk: Ideale geleentheid vir 'n eerste woning en vir die persoon wat graag self wil aanbou.

Nou oop vir besigheid.

Vir verdere besonderhede en besigtiging, kontak afslers: Johnie's Auctioneers, Afslers en Algemene Agente. Telefoon (012) 26-0706, Pretoria.

LEO AFSLAERS (EDMS.) BPK.

EIENDOMSVEILING

Insolvente Boedel: Verkoop van R/Ged. van Ged. 17 van die plaas Waterval No. 273, Registrasie Afdeling JR, Transvaal; Pretoria distrik; bekend as Plot No. 17, Waterval.

Daartoe gelas deur die voorlopige kurator, Mnr. P. D. Kruger van Cape Trustees Beperk in die Insolvente Boedel **S. M. Kleyhans, Meestersverwysing T1722/87**, verkoop ons per openbare veiling die volgende eiendom op die perseel op Saterdag, 24 Oktober 1987 om 10.30 vm.

1. *Eiendom:* R/Ged. van Ged. 17 van die plaas Waterval No. 273, Registrasie Afdeling JR, Transvaal; Pretoria distrik; bekend as Plot No. 17, Waterval.

Gesogte 8,5 ha perseel naby Pretoria met argitekbeplande luukse woning; 8,5 ha (90% ploegbaar), slegs 30 km noord van Pretoria op die Pietersburg snelweg; woning 462 m²; ou woning (store en bediendekamers); 1,2 m omheining; verdeel in 3 kampe; hoenderhok (144 m²); boogart, elektriese krag, veiligheidsomheining; swembad en "lapa".

2. *Terme:* 10% deposito en afslerskommissie (@ 7,5 % op die koopprys) per bankgewaarborgde tjek of kontant by die toeslaan van die bod. Waarborg vir die balans binne 30 dae na bekragtiging deur die kurator. Bekragtiging direk na afloop van die veiling. Volledige verkoopsvoorwaardes beskikbaar op aanvraag of op dag van besigtiging.

3. *Besigtiging:* Dag voor die veiling of reël met Afslaer.

Padbeskrywing: Neem Pietersburg snelweg uit Pretoria ± 25 km; draai links by Pyramid-Wahlmansthal-afdraai ± 1,5 km rigtingwyser regs.

4. *Afslersnota:* Geskik vir die sakeman en deeltydse boer, terwyl u teen die stad woon. 'n Pragwoning.

5. *Vir verdere besonderhede:* Kontak P. H. Human van Leo Afslers, Kantoor 505, Leeubrugsentrum, Kerkstraat 441, Pretoria, 0083. Tel. (012) 26-1326 of (012) 64-1265 alle ure.

WILBERS AFSLAERS, POSBUS 209, DELMAS, 2210 [Tel. (0157) 9675/4165/3180

INSOLVENTE VEILING VAN VASTE EIENDOM TE SECUNDA

Behoorlik daartoe gelas deur die Kurator J. H. van Blerk van Metboard (Pretoria) Bpk., van die Insolvente Boedel van **Ignatius Gustav van Rooyen (Meestersverwysingsnommer T1036/87), Identiteitsnommer 5411165006002**, sal ons per openbare veiling op Saterdag, 31 Oktober 1987 om 11h00 te Kommandant Fouriestraat 16, Uitbreiding 6, Secunda die volgende vaste eiendom verkoop:

Erf 2634, Uitbreiding 6 ook bekend as Kommandant Fouriestraat 16, Uitbreiding 6, Secunda. *Groot:* ± 985 vierkante meter, met teëldak, 3 slaapkamers, 1½ badkamers, sit/eetkamer met volvloer matte in sit/televiesiekamer en gang, televisiekamer, kombuis, toesluitmotorhuis. Erf omhein met beton omheining, gevestigde tuin en bediendekamer.

Verkoopsvoorwaardes: 'n Deposito van 15 persent in kontant of bankgewaarborgde tjek op dag van veiling die balans moet gewaarborg word binne 30 dae na bekragtiging deur die kurator. Volledige verkoopsvoorwaardes sal op dag van veiling voorgelees word.

Vir verdere besonderhede en besigtiging kontak die afslers: Wilbers Afslers: *Bedags:* Tel. (0157) 3126. *Na ure:* (0157) 4165 Frank; 3976 Boela; 3180 David.

WILBERS AFSLAERS, POSBUS 209, DELMAS, 2210 [Tel. (0157) 9675/4165/3180

INSOLVENTE VEILING VAN HUIS—TE DISCOVERY, ROODEPOORT

Behoorlik daartoe gelas deur die Kurator J. H. van Blerk van Metboard (Pretoria) Beperk van die Insolvente Boedel van **Gerhardus Christiaan Coetzee, Meestersverwysingsnommer T1302/87, Identiteitsnommer 5602015139007**, sal ons per openbare veiling op Saterdag, 24 Oktober 1987 om 11h00 by Erf 1756 ook bekend as Vyfdelaan 164, Uitbreiding 9, Discovery, Roodepoort die volgende vaste eiendom verkoop:

Erf 1756. *Groot:* ± 1 056 vierkante meter met teëldak, 3 slaapkamers, 2 badkamers, sit/eetkamer, kombuis, aparte opwas, volvloer matte, bediendekamer, enkel motorhuis met afdak. Huis in baie goeie toestand.

Voorwaardes van verkoop: 'n Deposito van 15% (persent) in kontant of bankgewaarborgde tjek en die balans moet gewaarborg word binne 30 dae na bekragtiging deur die Kurator. Volledige verkoopsvoorwaardes sal op die dag van die veiling gelees word.

Vir verdere besonderhede en besigtiging kontak die afslers: Wilbers Afslers: Tel. (0157) 3126 Boela; (0157) 4165 Frank; *Na ure* 3180 David; 3976 Boela.

TRAKMAN'S AUCTION SALES

Instructed thereto by The Trustee of Insolvent Estate **Andrew Ford, Master's Ref. T.1056/87**, we will sell Certain Erf 577, Boksburg South, at the Residence 1, Tulbagh Street, on Wednesday, 21st October 1987 at 10.30 a.m.

Terms: 20% by bank guaranteed cheque immediately and the balance within 30 days.

Phone (011) 614-7135.

Trakman's Auctioneers (Pty) Ltd, P.O. Box 66267, Broadway, 2020.

RIF AFSLAERS (EDMS.) BPK., REG. No. 85/02262/07

INSOLVENTE BOEDEL VEILING VAN LANDBOUHOEWE TE HEIDELBERG

In opdrag van die kurator van die Insolvente Boedel **D. R. Heroldt (T1449/87)**, verkoop ons per openbare veiling die ondergenoemde hoewe op die hoewe op 12 November 1987 om 11h00.

Eiendom: Gedeelte 28 ('n gedeelte van Gedeelte 1) van die plaas Goedgedacht 443, Registrasie Afdeling IR, Transvaal. Groot 5,3807 hektaar.

Beskrywing: Hoewe het opstal met buitegeboue, varkhokke, stalle, sinkdam, boorgat wat toegerus is met elektriese pomp. Hoewe word voorsien met EVKOM krag.

Afslaaersnota: Daar sal rigtingwysers wees vanaf die Boschkop afdraai uit die Vaaldampad tot op die hoewe.

Betalings terme: 20% Deposito met toeslaan van die bod en die balans binne 40 dae na bekragtiging deur middel van Bank- of Bouverenigings waarborge.

Navrae: Izak Bakker (012) 455471/2.

Rif Afslaaers (Edms.) Bpk., Posbus 914-1111, Wingate Park, 0153—Tel: 45-5471/2.

RADLEY VEILINGS BK, CK 87/02062/23

INSOLVENTE BOEDELVEILING VAN UITSTEKENDE SAAI- EN BEESPLAAS EN IMPLEMENTE—DISTRICK NABOOMSPRUIT

1. *Wanneer:* Vrydag, 30 Oktober 1987 om 11h00.

2. *Waar:* By die opstal van die plaas (sien ligging).

3. In opdrag van Mnr. J. N. Bekker, kurator, van die insolvente boedel **J. J. van der Merwe, T2071/87**, verkoop ons die volgende:

3.1 Resterende gedeelte van die plaas Zachariasboom No. 354 Reg. Afd. K R, Tvl, groot 1054,6747 ha. Op die plaas is 'n stewige woonhuis en sinkskuur asook 2 sementdamme, 15 gronddamme, 10 boorgate (4 toegerus), ens. Daar is ongeveer 265 ha uitstekende leem/turf lande (20 ha het 'n moederlyn vir besproeiing) en 788 ha soet versveld weiding wat ingedeel is in 5 kampe. Hierdie plaas wat in die Nyldelta geleë is, is as geheel onderbenut met die hoeveelheid water wat beskikbaar is.

3.2 *Implemente:* 1 × M/F Trekker 285, 1 × International Trekker 844 (stukkend), 1 × 4-ry Monoseum lugdrukplanter, 1 × Dambuster 1500 skrop, 1 × Riechbeer breedwerkskoffel, 1 × Soilmaster padskraaper, 1 × Soilmaster hidroliese eenrigting-skottelploeg, 1 × vetsak eenrigting-ploeg, 1 × Soilmaster tiller, 86 besproeiingspype (100 mm × 6 m), 20 besproeiingspype (40 mm × 6 m), los gereedskap, ens.

Voorwaardes: Slegs kontant of bankgewaarborgde tjeks vir roerende goedere, vir eiendom 20% van koopprijs by val van die hamer en balans 30 dae na goedkeuring.

Ligging: Vanaf Naboomspruit ry met Roedtanpad (R519) vir 10,6 km—draai links by Verwegpad en ry 12,4 km—draai links by Haakdoringpad en ry 5,5 km tot by plaas.

Vir verdere navrae skakel: Chris Radley by (012) 43-6374/5 bedags of (012) 45-2002 saans.

Radley Veilings BK, CK 87/02062/23.

U kan ons telefonies bereik by (012) 43-6374/5.

Korrespondensie vir ons moet gerig word aan Posbus 11202, Brooklyn, 0011.

Ons kantoor is te Hatfield Forum Wes (2de Verdieping), Arcadiastraat 1067, Hatfield, Pretoria.

UBIQUE AFSLAERS

In opdrag van die Voorlopige Kurator in die Insolvente Boedel **L. D. P. Raath, Meestersverwysing No. T.1690/87** sal ons die bates verkoop te die plaas Witpoort op 17 Oktober 1987 om 10 vm.

Terme: Kontant of bankgewaarborgde tjeks.

Telefoon: (01481) 7391 of 2-3841.

Ubique Afslaaers, Die Meent, Van Riebeeckstraat 123, Posbus 208, Potchefstroom.

THEO GOOSEN VEILINGS

In opdrag van die Kurator in die Insolvente Boedel van **A. J. Roux, Meestersverwysing No. T1080/87**, verkoop ons per publieke veiling op Dinsdag, 27 Oktober 1987 om 11h00 te Voortrekkerweg 14, Potgietersrus.

Vaste eiendom: Resterende Gedeelte van Erf 401 geleë in die dorp Piet Potgietersrust, Registrasie Afdeling K S, Transvaal. Groot 2231 m².

Verbetering: Woonhuis en buitegebou.

Voorwaardes: 10% (tien persent) deposito betaalbaar deur koper op veiling en balans gewaarborg te word binne 21 dae na bekragtiging.

Theo Goosen Afslaaers, Posbus 811, Pietersburg. Tel. (01521) 7-1153.

RIF AFSLAERS (EDMS.) BPK., REG. No. 85/02262/07

INSOLVENTE VEILING VAN WONINGS

In opdrag van die kurator van die Insolvente Boedel **J. M. Labuschagne (T1518/87)**, verkoop ons per openbare veiling die ondergenoemde twee huise op Donderdag, 22 Oktober 1987 om 10h00 op die perseel.

Eiendom 1: Erf 280 in die dorp Hendrina, Registrasie Afdeling IS, Transvaal. Groot 2855 m² ook bekend as Sluiterstraat 38, Hendrina, Transvaal.

Eiendom 2: Erf 281 in die dorp Hendrina, Registrasie Afdeling IS, Transvaal. Groot 2855 m², ok bekend as Sluiterstraat 40, Hendrina, Transvaal.

Beskrywing van eiendomme: Beide erwe het huise op. Die huise is baie verwaarloos sowel as die tuine.

Afslaaersnota: Daar is geen verbande op die eiendomme nie.

Betalings terme: 20% Deposito met die toeslaan van die bod en die balans binne 40 dae na bekragtiging deur middel van goedgekeurde bank- of bougenootskapswaarborge.

Navrae: Izak Bakker (012) 45-5471/2.

Rif Afslaaers (Edms.) Bpk., Posbus 914-1111, Wingate Park, 0153—Tel: 45-5471/2.

HERMAN DU PLESSIS EN SEUN AFSLAERS—DELAREYVILLE

Behoorlik daartoe gelas deur die Voorlopige Kurator van Insolvente Boedel P. J. W. Buys, Meestersverwysingsnommer T.2117/87, word die onderstaande woonhuis per Publiek Veiling verkoop op Vrydag, 6 November 1987 om 10h00, voor die Landdroskantoor, Delareyville.

1. *Beskrywing*: Gedeelte 159 van Lot 284, dorp Delareyville; Registrasie Afdeling I O, Transvaal.

Groot: 1 000 vierkante meter.

2. *Verbeteringe*: Die eiendom is verbeter met 'n ruim vierslaapkamer woonhuis met gesinskamer en dubbele geriewe.

3. *Terme van betaling*: 20% deposito onmiddellik en balans gewaarborg binne veertien dae na bekragtiging deur Kurator.

Vir verdere besonderhede en volledige voorwaardes kontak die Afslalers.

Telefoon 12, Delareyville.

PUBLIC AUCTIONS, SALES AND TENDERS

JACK KLAFF AUCTIONEERS

Duly instructed by the Trustee of the Insolvent Estate of **Rachel Bam**, Master's Reference No. T1095/87, I will sell the fixed property, 6 Dilly Street, Tzaneen, by Public Auction on Thursday, 29th October 1987 at 10.00 a.m. at the Tzaneen showgrounds.

Auctioneers: Jack Klaff, P.O. Box 1, Messina, 0900 [Telephone (01553) 2006].

Advertiser and address: Limvaal Trustees, P.O. Box 3548, Pretoria, 0001.

Date: 7th October 1987.

Reference: V. A. van Diggelen/JL.

PUBLIC AUCTIONS, SALES AND TENDERS

JACK KLAFF AUCTIONEERS

Duly instructed by the Trustee of the Insolvent Estate of **Johannes Badenhorst**, Master's Reference No. T. 1242/87, I will sell the fixed property and moveables by Public Auction on Thursday, 29th October 1987 at 10.00 a.m. at the Tzaneen showgrounds.

Auctioneers: Jack Klaff, P.O. Box 1, Messina, 0900 [Telephone (01553) 2006].

Advertiser and address: Limvaal Trustees, P.O. Box 3548, Pretoria, 0001.

Date: 7th October 1987.

Reference: V. A. van Diggelen/JL.

VENDOR AFSLAERS BK

Boedelveiling van woonhuis te Kinross, Transvaal, op 22 Oktober 1987 om 11h00 te Tambotiestraat 4, Kinross.

In opdrag van die Kurator in die Insolvente Boedel van **Andries Jacobus Roux (T1080/87)**, verkoop ons per openbare veiling die vaste eiendom tesame met alle verbeterings daarop en bekend as Erf 1321, geleë in die dorpsgebied Kinross, Uitbreiding 12, Registrasie Afdeling I.S., Transvaal; groot 1232 vierkante meter.

Afslalersnota: Die eiendom beskik oor 'n 3 slaapkamer woonhuis met sit cum eetkamer, aparte badkamer en toilet, kombuis, bediende toilet en motorafdak.

Besigtig: Gereël te word met die Afslalers.

Betaling: Tien (20) persent van die koopprys in kontant of per bankgewaarmerkte tjek by die toeslaan van die bod. Die balanskoopsom moet verseker word deur middel van 'n aanvaarbare waarborg binne dertig (30) kalenderdae vanaf datum van bekragtiging van die transaksie deur die Verkoper.

Verkoopsvoorwaardes: Die eiendom word verkoop onderhewig aan sodanige verdere verkoopsvoorwaardes soos wat bekend gemaak sal word op die dag van die veiling. Die Verkoper sowel as die Afslalers behou hulself egter die reg voor om hierdie verkoping te enige tyd voor of gedurende die plaasvind daarvan af te las, sonder opgaaf van redes.

Vir verdere besonderhede kontak: Venditor Afslalers BK, Posbus 16, Marken, 0605 [Tel. (01536) 5-0127/8].

BARNETT SALES CC

Gold Seal Motors (Pty) Ltd, in liquidation, Masters Ref. T2188/87, 24 Wynberg Road, Kew, panelbeating equipment, scrap metals, secondhand motor spares, sale takes place at premises on Thursday, 22/1/87 at 10.30.

Barnett Sales CC, (85/13388/23), 32 Troye Street, Johannesburg, telephone 29-4881 or 23-5211.

J. C. BURCHMORE (PTY) LIMITED

D & K Peterson Bros (Pty) Limited, in liquidation, t/a **Honda World**, Masters Reference Number T1483/87.

Duly instructed by the Liquidator in the above matter we shall sell by public auction office furniture, motor bike spares, Honda Motor Cycle, Mazda Bakkie etc., on Monday, 19th October 1987 at 10.30 p.m. at our sales rooms, 104 Frederick Street, Johannesburg.

For further details kindly contact the auctioneers: J. C. Burchmore (Pty) Limited, 104 Frederick Street, corner of Smal Street, Johannesburg. [Tel. (011) 331-8591].

A.D. WANNENBURG AFSLAER

In opdrag van die Kurator in die Insolvente Boedel van **Stephanus Johannes Naude**, Meestersverwysing T1317/87 verkoop ons per openbare veiling op Saterdag, 24 Oktober 1987 om 11h00 die volgende eiendom voetstoots op die perseel.

Sekere Erf 309, geleë in die dorpsgebied Arcon Park, Vereniging, Registrasie Afdeling I.Q., Transvaal. Groot 991 m² gehou kragtens akte van Transport T22872/83.

Verbeterings sluit in 3 slaapkamerwoning met swembad.

Groot verband beskikbaar.

Vir meer besonderhede skakel afslaer by 22-0199.

A.D. Wannenburg Afslaer, Posbus 771, Vanderbijlpark, 1900. Tel. (016) 22-0199.

INTERNATIONAL AUCTIONEERING COMPANY

Insolvent Estate **G. J. Palkowich (Masters Ref. No. T 3950/86)**, vacant stand—No. 14 Kromiet Ave., Croydon Ext. 1, Kempton Park.
At our mart at 66 Tyrone Avenue, Parkview, Johannesburg, at 2 p.m., Tuesday, 20 October 1987.
International Auctioneers, Tel. 646-8357/8.
Partners: E. G. Bonini, J. P. Bruyns.
66 Tyrone Avenue, Parkview, Johannesburg; P.O. Box 41458, Craighall, 2024.
Tel: 646-8357/8 and 646-8356. Natal Office: P.O. Box 176, Umhlanga Rocks, 4320. Tel: (031) 52-4163.

INTERNATIONAL AUCTIONEERING COMPANY

Sports Scene (Pty) Ltd, in liquidation (Masters Ref. No. T 2002/87). Prince stringing machine, sports clothing, tracksuits, cricket bats, hockey sticks, shop fittings and fixtures, etc., etc.
At our mart at 66 Tyrone Avenue, Parkview, Johannesburg, at 10 a.m., Tuesday, 20 October 1987.
International Auctioneers, Tel. 646-8357/8.
Partners: E. G. Bonini, J. P. Bruyns.
66 Tyrone Avenue, Parkview, Johannesburg; P.O. Box 41458, Craighall, 2024.
Tel: 646-8357/8 and 646-8356. Natal Office: P.O. Box 176, Umhlanga Rocks, 4320. Tel: (031) 52-4163.

INTERNATIONAL AUCTIONEERING COMPANY

Strand Wholesalers (Pty) Ltd, in liquidation (Masters Ref. No. T1748/87). Assorted rolls material, 7 000 pairs boys trousers, dust coats, belts, zips, office furniture, etc., etc.
At our mart at 66 Tyrone Avenue, Parkview, Johannesburg, at 10 a.m., Tuesday, 20 October 1987.
International Auctioneers, Tel. 646-8357/8.
Partners: E. G. Bonini, J. P. Bruyns.
66 Tyrone Avenue, Parkview, Johannesburg; P.O. Box 41458, Craighall, 2024.
Tel: 646-8357/8 and 646-8356. Natal Office: P.O. Box 176, Umhlanga Rocks, 4320. Tel: (031) 52-4163.

PHIL MINNAAR (BK) AFSLAERS

VEILING

INSOLVENTE BOEDELVEILING VAN NETJIESE WOONHUIS TE ROOIHUISKRAAL, UITBREIDING 18

In opdrag van die Kurator in die Insolvente Boedel van **J. van der Merwe, T2669/87**, verkoop ons die volgende eiendom op Vrydag, 23 Oktober 1987 om 10h00 by die perseel.
Erf 1736, Rooihuiskraal, Uitbreiding 18, Verwoerdburg, groot 1 400 m², beter bekend as Maraboestraat 172, Rooihuiskraal.
Hierdie eiendom bestaan uit 'n netjiese siersteenwoning met teëldak, 3 slaapkamers, 2 badkamers, sit/eetkamer, volvloermatte, netjiese kombuis met ingeboude kaste en nuwe Defy stoof, toesluit motorhuis, buite-toilet, baksteen-omheining en plaveisel.
Terme: 20% Deposito by toeslaan van bod, balans gewaarborg binne 45 dae na bekragtiging.
Phil Minnaar (BK) Afslaers, CK 85/01372/73, Skinnerstraat 405; Posbus 28265, Sunnyside, 0132. Tel. 325-1316/7/8/9, Pretoria.

PHIL MINNAAR (CC) AUCTIONEERS

AUCTION

INSOLVENT ESTATE AUCTION OF A NEAT DWELLING AT ROOIHUISKRAAL, EXTENSION 18

Duly instructed by the Trustee in the Insolvent Estate of **J. van der Merwe, T2669/87**, we are selling the following property on Friday, 23 October 1987 at 10h00 on site.
Erf 1736, Rooihuiskraal, Extension 18, Verwoerdburg, measuring 1 400 m², also known as 172 Maraboe Street, Rooihuiskraal.
This property consists of a neat facebrick dwelling with 3 bedrooms, 2 bathrooms, lounge, diningroom, wall-to-wall carpets, a neat kitchen with built-in cupboards and new Defy stove, lock-up garage, outside toilet, brick fencing and paving.
Terms: 20% Deposit at the fall of the hammer, balance guaranteed within 45 days after approval.
Phil Minnaar (CC) Auctioneers, CK 85/01372/73, 405 Skinner Street; P.O. Box 28265, Sunnyside, 0132. Tel. 325-1316/7/8/9, Pretoria.

PHIL MINNAAR (BK) AFSLAERS

VEILING

INSOLVENTE BOEDELVEILING VAN WOONHUIS MET WOONSTEL TE WINGATE PARK, UITBREIDING 1

In opdrag van **J. van Rensburg van Cape Trustees**, Kurator, in die Insolvente Boedel van **P. Smit, T273/87**, verkoop ons die volgende eiendom op Vrydag, 23 Oktober 1987 om 12h00 by die perseel.
Erf 691, geleë in die dorpsgebied Wingate Park, Uitbreiding 1, Reg. Afd. JR, Tvl., groot 2 349 m², beter bekend as Amalgam Crescent 57, Wingate Park, Uitbreiding 1.
Hierdie eiendom bestaan uit 'n woonhuis met 2 slaapkamers, badkamer, sitkamer, eetkamer, kombuis, portaal en gang. *Woonstel:* 3 slaapkamers, badkamer, sitkamer, eetkamer/kombuis en gang. Die oppervlakte van gebou is 183,561 m².
Afslaersnota: Die gebou is nog in 'n proses van aanbou.
Terme: 10% Deposito by toeslaan van bod, balans binne 45 dae na bekragtiging. Afslaerskommissie van 7,5% word deur die koper betaal.
Phil Minnaar (BK) Afslaers, CK 85/01372/73, Skinnerstraat 405; Posbus 28265, Sunnyside, 0132. Tel. 325-1316/7/8/9, Pretoria.

PHIL MINNAAR (CC) AUCTIONEERS**AUCTION****INSOLVENT ESTATE AUCTION OF DWELLING WITH FLAT AT WINGATE PARK, EXTENTION 1**

Duly instructed by J. van Rensburg of Cape Trustees, Trustee in the Insolvent Estate of P. Smit, T273/87, we are selling the following property on Friday, 23 October 1987 at 12h00 on site.

Erf 691, situated in the township of Wingate Park, Extension 1, Reg. Div. JR, Tvl., measuring 2 349 m², also known as 57 Amalgam Crescent, Wingate Park, Extension 1.

This property consists of a dwelling with 2 bedrooms, bathroom, lounge, diningroom, kitchen, porch and passage. Flat: 3 bedrooms, bathroom, lounge, diningroom/kitchen and passage. The area of this building is 183,561 m².

Auctioneers' note: This building is still under construction.

Terms: 10% Deposit at the fall of the hammer, balance within 45 days after confirmation. Auctioneers' commission of 7,5% to be paid by the buyer.

Phil Minnaar (CC) Auctioneers, CK 85/01372/73, 405 Skinner Street; P.O. Box 28265, Sunnyside, 0132. Tel. 325-1316/7/8/9, Pretoria.

PHIL MINNAAR (BK) AFSLAERS**VEILING****INSOLVENTE BOEDELVEILING VAN WOONHUIS TE WATERKLOOF GLEN**

In opdrag van L. Klopper, Kurator in die Insolvente Boedel van K. F. Pienaar, T1725/87, verkoop ons die volgende eiendom op Vrydag, 23 Oktober 1987 om 13h00 by die perseel.

Erf 483, geleë in die dorpsgebied Waterkloof Glen, Uitbreiding 2, Reg. Afd. JR, Tvl., groot 1 239 m², beter bekend as Corobaylaan 210, Waterkloof Glen.

Hierdie woning bestaan uit 3 slaapkamers, badkamer, sitkamer, eetkamer, kombuis, volvloermatte, onthaal- en braaigebied met plaveisel, swembad, motorhuis, motorafdak en gevestigde tuin.

Terme: 20% Deposito by toeslaan van bod, balans gewaarborg binne 45 dae na bekragtiging.

Phil Minnaar (BK) Afslers, CK 85/01372/73, Skinnerstraat 405; Posbus 28265, Sunnyside, 0132. Tel. 325-1316/7/8/9, Pretoria.

PHIL MINNAAR (CC) AUCTIONEERS**AUCTION****INSOLVENT ESTATE AUCTION OF DWELLING AT WATERKLOOF GLEN**

Duly instructed by L. Klopper, Trustee in the Insolvent Estate of K. F. Pienaar, T1725/87, we are selling the following property on Friday, 23 October 1987 at 13h00 on site.

Erf 483, situated in the township Waterkloof Glen, Extension 2, Reg. Div. JR, Tvl., measuring 1 239 m², also known as 210 Corobay Avenue, Waterkloof Glen.

This dwelling consist of 3 bedrooms, bathroom, lounge, diningroom, kitchen, wall to wall carpets, entertain and braai area with paving, swimming-pool, garage, carport and established garden.

Terms: 20% Deposit at the fall of the hammer, balance guaranteed within 45 days after approval.

Phil Minnaar (CC) Auctioneers, CK 85/01372/73, 405 Skinner Street; P.O. Box 28265, Sunnyside, 0132. Tel. 325-1316/7/8/9, Pretoria.

MKL-AFSLAERS**VEILING**

Behoorlik daartoe gelas deur die Kurator van John Christopher Bouwer, voorheen handelende as Drakensberg Slaghuis, Sabie (Meestersverwysing No. T1759/87), sal die onderstaande losbates verkoop word.

Datum van veiling: Saterdag, 31 Oktober 1987 om 09h00.

Plek van veiling: Winkelperseel, Drakensberg Slaghuis, geleë in Knipschildes-gebou, Hoofstraat, Sabie (volg aanwysingsborde van Afslers).

Losbates: Olivetti Mercator 10 (kontantlaai), toonbank, pine-lessenaar met 3 laaie, gestoffeerde stoele, lessenaarstoele, groot Fuchsware Andair yskas (kis), Ocean L215 vrieskas, Frigidaire vrieskas, Bishoff Cub brandkluis, lessenaar met 3 laaie (1 laai stukkend), Yamato ecocell skaal, bedieningstonbank, tafel vir vleisbewerking, vleisbandsaag OKTO 15kW Serial 8640, Olympic biltongkerwer, Sanitary-tenderizer, Bizerba polonysnyer, staaltafeltjie, witkas, Columbit plastiese verpakker, pine-toonbank, Bizerba skaal, staaltafel, staalbewerkingstafel, Cecomatic staaltafel, Biro vleismeule, staalwasbak met Meissner Press worsstopper, Fushware vrieskas (kis), vleissaag (hand), skinkborde (staal), trollies, brandblusser, Rentokil vlieëvanger, klein tafeltjie, plastiekbakke (groot), staalstaander met 8 rakke, elektriese ketels, sonskern, verskeie slagtersstaalhakke.

Betaling: Slegs kontant of bankgewaarborgde tjeks.

Besigtiging: Slegs vanaf 08h00 op dag van veiling.

Verkoopsvoorwaardes: Lê ter insae by Afslerskantoor.

Verdere besonderhede: Skakel M K L Afslers, Nelspruit (01311) 2-3247, P. J. du Pleez, of J. A. van Rensburg.

MKL-Afslers, Derde Verdieping, Nedbanksentrum, Brownstraat; Posbus 851, Nelspruit, 1200. Fax (01311) 27347. Teleks 33-5228 SA.

PUBLIEKE VEILING**WOONERF****INSOLVENTE BOEDEL VEILING: WOONERF TE NEWLANDS X2, PRETORIA**

In opdrag van die Kurator in die Insolvente Boedel van H. J. Kriek, verkoop ons per openbare veiling sonder reserwe die ondergemelde eiendom op die 23ste Oktober 1987, die ondergemelde eiendom te ons kantore: Grond Verdieping, Eilimggebou, Proesstraat 181, Pretoria.

Eiendom: Erf 334, geleë in die dorpsgebied Newlands, Pretoria, Uitbreiding 2, Registrasie Afdeling J.R. Transvaal. Groot 1355 vierkante meter.

Plek, datum en tyd: Ons kantore te Grondverdieping, Elimgebou, Proesstraat 181, Pretoria, om 12h00 op 23 Oktober 1987.

Verkoopsvoorwaardes: 20% van die koopprijs in kontant, of bankgewaarborgde tjek onmiddellik by toestaan van die bod. Die balans moet verseker word deur 'n bank of bougenootskap waarborg binne 30 dae na bekragtiging van die koop.

Afslaaers nota: Hierdie is een van die enkele onbeboude woonerwe in hierdie pragtdorp. Hoog teen die kop met 'n lieflike uitsig. Hierdie woonerf is een van die beste erwe in Pretoria se voorstede en moet gesien word om die uitsig te waardeer.

Afslaaers: PRO-AUC Afslaaers BK, Elimgebou, Proesstraat 181, Pretoria. Telefoonnommer: 21-8785/6.

VEILING VAN PLUIMVEE TOERUSTING

Behoorlik daartoe gelas deur die Kurator, Jan van Blerk van Metboard (Pretoria) Beperk, in die Insolvente Boedel van **M. du Preez Jones** (Meestersverwysingsnommer T262/87), sal ons verkoop op Vrydag, 23ste Oktober 1987 om 11h00, te Plot 116, 10de Laan, Eloff, die volgende toerusting:

1 × doodskokmasjien.

1 × waterverwarmer.

1 × vereplukker.

'n hoeveelheid drinkbakke.

'n hoeveelheid kosbakke.

Voorwaardes van verkoop: "Voetstoots" vir kontant of bankgewaarborgde tjeks.

Ligging: Te Plot 116, 10de Laan, Eloff, Distrik Delmas.

Vir meer besonderhede kontak die afslaaers: Wilbers Afslaaers: 3126 kantore ure; 9675 Boela (na ure); 4165 Frank (na ure); 3180 David (na ure).

KAAP • CAPE

OPENBARE VEILING

Gelas deur die kurators in die insolvente boedel van **David Charles Hugh Butler**, No. C.452/87 sal ondergemelde sekere Erf 7547, Kraaifontein, bekend as Limpopostraat 22, Kraaifontein, tesame met los meubels per openbare veiling te koop aangebied word te die vaste eiendom op 23 Oktober 1987 om 11h00.

J. J. J. Bester, p/a Prestige Afslaaers, Northumberlandweg, Bellville. Tel: 92-9629.

NATAL

ALFRED COUNTY ESTATE AGENTS (PTY) LTD, REG. No. 69/09161/07

Duly instructed by the Trustee of the Insolvent Estate **S. W. Louw**, Master's Ref. No. 698/86 the following property will be auctioned on Tuesday, 3rd November 1987 at 11 a.m. on site.

Lot 947, Ramsgate, Ramsgate Town Board, Lower South Coast Regional Water Services area, Administrative District of Natal, in extent One Thousand One Hundred and seventy-eight (1,178) square metres.

Conditions of sale:

(1) The Purchaser shall pay 10% of the Purchase Price on signature of the Conditions of Sale and the balance in cash only against registration of Transfer and not before, with interest on any unpaid part of the purchase price at the rate of 13,5% per annum from the date of possession to the date of Transfer.

(2) The full Conditions of Sale may be inspected at the offices of the Auctioneers, 19 Aiken Street, Port Shepstone, and these will be read out by the Auctioneer immediately before the sale.

The following information is furnished, although in this respect nothing is guaranteed.

Improvements: Brick under tile double storey house with 4 bedrooms, fitted kitchen, 2½ bathrooms, separate diningroom, lounge, double garage and double servants rooms.

Alfred County Estate Agents (Pty) Ltd, Auctioneers, P.O. Box 98, Port Shepstone, 4240.

PUBLIC AUCTIONS

FURNITURE, HOUSEHOLD, UTENSILS & CLOTHING

Public auction of movables in the Insolvent Estate **Michael James Brady**, Master's Ref. N681/86.

Comprising: A Scrap Rover 2.6 Sedan, and a scrap short wheel base Land Rover, together with an assortment of hand tools and spare wheels will be sold by Public Auction at Howes Auction Sales, Port Shepstone at 11h00 on Wednesday, 21 October 1987.

All details from the Auctioneer Peter Bristow at Telephone No. (0391) 2-0003.

Harley, Morris & Robinson, c/o Klagsbruns Partnership, Corporate Place, 287 Struben Street, Pretoria, 0002 (Ref: Mr Knobel/BRM.5436). 3/10/87. Tel. 21-2241.

ORANJE-VRYSTAAT • ORANGE FREE STATE

INSOLVENTE BOEDELVEILING

In opdrag van die kurator in die Insolvente Boedel van **W. F. Boshoff**, No. D170/87, sal die volgende eiendom op Saterdag, 24 Oktober 1987 om 10h00 sonder reserweprijs, maar onderworpe aan bevestiging, per openbare veiling verkoop word te Landdrosstraat 1a.

Eiendom geleë te: Landdrosstraat 1a.

Groot: 929 vierkante meter.

Ligging: Erf Nommer 235, in die munisipale gebied van Bethlehem.

Verkorte verkoopsvoorwaardes: 10% van die koopprijs in kontant of bankgewaarborgde tjek onmiddellik na die veiling.

Die balans van die koopprys moet verseker word deur 'n bank- of bougenootskapswaarborg binne 30 dae na bekragtiging van die koop deur die kurator.

Besigtiging en nadere besonderhede: Skakel Karoo Osche, Boshoffstraat. Telefoonnommer (01431) 3-5361; of die kurator F. A. du Preez, p/a Peach & Du Preez, Rouxstraat 36b, Bethlehem. Telefoon (01431) 3-5217.

Roerende goed: 1985-model Toyota 1600 voertuig.

NAAMSVERANDERING • CHANGE OF NAME WET OP VREEMDELINGE, 1937

Die onderstaande kennisgewings van voorneme om by die Staatspresident aansoek te doen om 'n ander van aan te neem, word ingevolge artikel 9 van Wet 1 van 1937 vir algemene inligting gepubliseer. Enigeen wat daarteen beswaar het dat die genoemde van aangeneem word, moet sy/haar beswaar met vermelding van redes daarvan so gou moontlik skriftelik by die Landdros genoem in die betrokke kennisgewing, indien.

Die inligting word, waar van toepassing, verstrek in die volgorde: (1) Applikant(e) se volle name en van, en of minderjarige(s); (2) woonadres; (3) besigheid of beroep; (4) indien 'n aansoek ten opsigte van kinders onder 10 jaar, die naam (name); (5) die van wat aangeneem word; (6) die redes daarvoor; (7) die naam (name) voorheen gedra indien anders as onder (1) of (4), respektiewelik; (8) die name van vrou en kinders indien by die aansoek ingesluit; (9) bygestaan, indien so, deur; besware in te dien by die Landdros te.

THE ALIENS ACT, 1937

The undermentioned notices of intention to apply to the State President to assume a different surname are published in terms of section 9 of Act 1 of 1937. Any person who objects to the assumption of the said surname should lodge his/her objection, in writing, stating full reasons therefor, to the Magistrate mentioned in the relevant notice.

The information, where applicable, is given in the following order: (1) Full names and surname of applicant(s), and whether minor(s); (2) residential address; (3) business carried on, or occupation; (4) if an application in respect of children under 10 years, the name(s); (5) the surname to be assumed; (6) the reasons therefor; (7) the name(s) previously borne, if other than under (1) or (4), respectively; (8) the names of wife and children, if included in the application; (9) assisted, if so, by; objections to be lodged with the Magistrate of.

TRANSVAAL

THE ALIENS ACT, 1937

NOTICE OF INTENTION OF CHANGE OF SURNAME

I, **Gavin Peter Howard**, a minor child, residing at 3 Gen. de Wet Road, Voortrekkerhoogte, Pretoria, intend applying to the Minister of Home Affairs for authority under section 9 of the Aliens Act, 1937, to assume the surname **Marshall** for the reason that I have been known as Marshall since January 1975. I am being assisted in this application by my mother **Mrs. Gwynneth Joyce Marshall**.

Any person who objects to my assumption of the said surname of **Marshall** should as soon as may be lodge his objection, in writing, with a statement of his reasons therefor, with the Magistrate of Pretoria.—G. P. Howard, 27/9/87.

16-23

THE ALIENS ACT, 1937

NOTICE OF INTENTION OF CHANGE OF SURNAME

I, **Richard Martin Evans**, residing at 49 Farrell Street, Hazelpark, Germiston, 1401, a Student, intend applying to the Minister of Home Affairs for authority under section 9 of the Aliens Act, 1937, to assume the surname **Shedlock** for the reasons that my natural father died before I was one year old and the only father I have known is my stepfather Rowen Alfred Battye Shedlock. I previously bore the name **Evans**.

Any person who objects to my assumption of the said surname of **Shedlock** should as soon as may be lodge his objection, in writing, with a statement of his reasons therefor, with the Magistrate of Germiston.—R. M. Evans, 28/8/87.

16-23

THE ALIENS ACT, 1937

NOTICE OF INTENTION OF CHANGE OF SURNAME

I, **Mokgosi Jacob Ditsi**, residing at 560 Zone 3, Meadowlands, Soweto, and employed as Machine Operator by the firm Kalamazoo Business Systems, 9 Ruven Road, Johannesburg, intend applying to the Minister of Home Affairs for authority under section 9 of the Aliens Act, 1937, to assume the surname **Dickson** for the reasons that my late father's registered name was Joseph Dickson. My mother remarried one Johann Ditsi and applied for a reference book for me in the name of Ditsi, I wish to be known by my own father's name. I intend also applying for authority to change the surname of my minor child **Catherine** to **Dickson**.

Any person who objects to our assumption of the said surname of **Dickson** should as soon as may be lodge his objection, in writing, with a statement of his reasons therefor, with the Magistrate of Johannesburg.—M. J. Ditsi, 30 September 1987.

16-23

THE ALIENS ACT, 1937

NOTICE OF INTENTION OF CHANGE OF SURNAME

I, **Mahomed Rafeek Brijmohan**, residing at 836 Hyde Street, Lenasia South, and employed as Clerical Worker, intend applying to the Minister of Home Affairs for authority under section 9 of the Aliens Act, 1937, to assume the surname **All** for the reasons that I have always been referred to as Ali, and am known as such by all friends and family. I previously bore the name **Brijmohan**. I intend also applying for authority to change the surname of my wife **Fawzia Brijmohan** and minor children **Adela Brijmohan** and **Asif Mohammed Brijmohan** to **Alie**.

Any person who objects to our assumption of the said surname of **All** should as soon as may be lodge his objection, in writing, with a statement of his reasons therefor, with the Magistrate of Johannesburg.—M. F. Brijmohan, 18/9/87.

16-23

DIE WET OP VREEMDELINGE, 1937

KENNISGEWING VAN VOORGENOME VANSVERANDERING

Ek, **Jacobus Coenraad Thompson**, woonagtig te Landbou Kollege, Potchefstroom, 'n student, is voornemens om by die Minister van Binnelandse Sake aansoek te doen om magtiging kragtens artikel 9 van die Wet op Vreemdelinge, 1937, om die van **Pitout** aan te neem om die volgende redes: Het groot geword met Mnr. Pitout as my vader, sedert my moeder in die huwelik bevestig is met genoemde. Ek het voorheen die name gedra van Jacobus Coenraad Thompson.

Enigeen wat daarteen beswaar het dat ek bovermelde van **Pitout** aanneem, moet sy beswaar, met vermelding van redes daarvoor, so gou moontlik skriftelik by die Landdros van Potchefstroom indien.—J. C. Thompson, 4/9/87.

9-16

KAAP • CAPE

THE ALIENS ACT, 1937

NOTICE OF INTENTION OF CHANGE OF SURNAME

I, **Eric Jeremy Naidoo**, residing at 30 Osterley Road, Crawford, intend applying to the Minister of Home Affairs for authority under section 9 of the Aliens Act, 1937, to assume the surname **Kirkwood** for the reasons that in terms of Section 5 (4) (c) of Act 30 of 1950 I have been reclassified as Coloured all my association and life i.e., business, social and spiritual is within the Coloured Community and for convenience the said name of Kirkwood is more in accord with the community with whom I associate. I previously bore the name **Naidoo**.

Any person who objects to my assumption of the said surname of **Kirkwood** should as soon as may be lodge his objection, in writing, with a statement of his reasons therefor, with the Magistrate of Cape Town.—E. J. Naidoo, 18 September 1987.

16-23

THE ALIENS ACT, 1937

NOTICE OF INTENTION OF CHANGE OF SURNAME

I, **Ashik Hoosain Yacoob**, residing at 27 Middel Road, Rylands, Athlone, 7764, occupied as a Student, intend applying to the Minister of Home Affairs for authority under section 9 of the Aliens Act, 1937, to assume the surname **Bray** for the reason that my father's first name has erroneously been entered as my surname on my birth certificate. I previously bore the name **Yacoob**.

Any person who objects to my assumption of the said surname of **Bray** should as soon as may be lodge his objection, in writing, with a statement of his reasons therefor, with the Magistrate of Wynberg.—A. H. Yacoob, 6/10/87.

16-23

DIE WET OP VREEMDELINGE, 1937

KENNISGEWING VAN VOORGENOME VANSVERANDERING

Ek, **Matteüs Johannes Kleingeld**, woonagtig te Die Palms No. 6, Kusweg, Die Strand, 7140, is voornemens om by die Minister van Binnelandse Sake aansoek te doen om magtiging kragtens artikel 9 van die Wet op Vreemdelinge, 1937, om die van **Lötter** aan te neem.

Enigeen wat daarteen beswaar het dat ek bovermelde van **Lötter** aanneem, moet sy beswaar, met vermelding van redes daarvoor, so gou moontlik skriftelik by die Landdros indien.—M. J. Kleingeld, 7 September 1987.

16-23

THE ALIENS ACT, 1937

NOTICE OF INTENTION OF CHANGE OF SURNAME

I, **David Hepburn Brown**, residing at Radies Vlei N2, District of Grahamstown; Private Bag X1563, Grahamstown, 6140, and employed as Farm Manager, intend applying to the Minister of Home Affairs for authority under section 9 of the Aliens Act, 1937, to assume the surname **Hepburn-Brown** for the reasons that Hepburn has been a family name since 1800 and I have been known by this name since starting my schooling. I previously bore the name **David Hepburn Brown**. I intend also applying for authority to change the surname of my wife **Sandra Maureen Brown**, née Waddingham to **Sandra Maureen Hepburn-Brown**.

Any person who objects to our assumption of the said surname of **Hepburn-Brown** should as soon as may be lodge his objection, in writing, with a statement of his reasons therefor, with the Magistrate of Grahamstown.—D. Hepburn Brown, 26/9/87.

9-16

NATAL

THE ALIENS ACT, 1937

NOTICE OF INTENTION OF CHANGE OF SURNAME

I, **Sani Simon Hlongwane**, residing at 1262 Sibongile Location, Dundee, and employed as Group Leader at Alucab (Pty) Ltd, Dundee, intend applying to the Minister of Home Affairs and National Education for authority under section 9 of the Aliens Act, 1937, to assume the surname **Mlambo** for the reason that it is my father's surname. I previously bore the name **Hlongwane**.

Any person who objects to my assumption of the said surname of **Mlambo** should as soon as may be lodge his objection, in writing, with a statement of his reasons therefor, with the Magistrate of Dundee.—S. S. Hlongwane, 28 September 1987.

16-23

THE ALIENS ACT, 1937

NOTICE OF INTENTION OF CHANGE OF SURNAME

I, **Ronnie Naidoo**, residing at 48 Croftdene Drive, Croftdene, Chatsworth, 4092, and employed as Product Advisor, International Data Services (Durban Branch), intend applying to the Minister of Home Affairs for authority under section 9 of the Aliens Act, 1937, to assume the surname **Errayiah** for the reason that I was incorrectly registered as Naidoo and would now like to rectify this matter. I previously bore the name **Ronnie Naidoo**.

Any person who objects to my assumption of the said surname of **Errayiah** should as soon as may be lodge his objection, in writing, with a statement of his reasons therefor, with the Magistrate of Chatsworth, Private Bag X001, Chatsworth, 4030.—R. Naidoo, 25/9/87.

9-16

THE ALIENS ACT, 1937

NOTICE OF INTENTION OF CHANGE OF SURNAME

I, **Bantu Bernard Tshonga**, residing at Gcilima Location, Ramsgate, District of Port Shepstone, and employed as Head Waiter at Village of Happiness, Margate since 1967, intend applying to the Minister of Home Affairs for authority under section 9 of the Aliens Act, 1937, to assume the surname **Manyisa** for the reasons that I always was known by the surname **Manyisa** and at work I am known by that surname only. I previously bore the name **Tshonga**. I intend also applying for authority to change the surname of my wife **Josephine Tholiwe Tshonga** and minor children **Bekisile Winnet Tshonga**, **Sollwe Linda Tshonga**, **Zodwa Brondy Tshonga** and **Muziwakhe Wonderhoy Tshonga** to **Manyisa**.

Any person who objects to our assumption of the said surname of **Manyisa** should as soon as may be lodge his objection, in writing, with a statement of his reasons therefor, with the Magistrate of Port Shepstone.—B. B. Tshonga, 11 September 1987.

9-16

THE ALIENS ACT, 1937

NOTICE OF INTENTION OF CHANGE OF SURNAME

I, **Rajendra Kumar Mahadev**, residing at 10 Gannet Grove, Albersville, Port Shepstone, 4240, and is unemployed intend applying to the Minister of Home Affairs for authority under section 9 of the Aliens Act, 1937, to assume the surname **Singh** for the reason that I have been and am known by the surname **Singh**. I previously bore the name **Rajendra Kumar Mahadev**.

Any person who objects to my assumption of the said surname of **Singh** should as soon as may be lodge his objection, in writing, with a statement of his reasons therefor, with the Magistrate of Port Shepstone, Private Bag 845, Port Shepstone, 4240.—R. K. Mahadev, 16/9/87.

9-16

ORANJE-VRYSTAAT • ORANGE FREE STATE

DIE WET OP VREEMDELINGE, 1937

KENNISGEWING VAN VOORGENOME VANSVERANDERING

Ek, **Johanna Jacoba van Wyk**, gebore Faure, woonagtig te Waterstraat 23, Vredefort, is voornemens om by die Minister van Binnelandse Sake aansoek te doen om magtiging kragtens artikel 9 van die Wet op Vreemdelinge, 1937, om die van van my minderjarige kind **Yolanda Liziël van Wyk** te verander na my nooiensvan naamlik **Faure**. Die redes daarvoor is dat ek en die vader van die kind reeds twee jaar geskei is en hoegenaamd geen kontak meer het nie. Hy betaal ook geen onderhoud aan ons nie, toon geen belangstelling aan sy kind nie, en kan ook nie opgespoor word nie. Ek sien nie my weg oop om my kind onder 'n van groot te maak van 'n man wat sy kind onteien nie. Ek het ook my nooiensvan teruggeneem.

Enigeen wat daarteen beswaar het dat sy bovermelde van **Faure** aanneem, moet sy beswaar, met vermelding van redes daarvoor, so gou moontlik skriftelik by die Landdros indien.—J. J. van Wyk.

9-16

SLAGTERSKENNISGEWINGS • BUTCHERS' NOTICES

RAAD VAN BEHEER OOR DIE VEE- EN VLEISNYWERHEDE

Enige persoon wat beswaar het teen die oprigting, oordrag of verskuiwing van die vermelde besigheid of die kansellasie van 'n registrasie kan sy beswaar indien in die vorm van 'n eedsverklaring, in drievoud, by die Raad se kantoor soos in die kennisgewing aangedui en binne die tydperk soos vermeld.

Die inligting word, waar van toepassing, verstrekk in die volgorde: (1) Dorpsgebied of distrik, afdeling, county; (2) applikant; (3) aard van aansoek (nuwe registrasie, oordrag, verskuiwing) en aard van besigheid; (4) besonderhede van perseel of plek (beskrywing, nommer, ligging en/of adres); (5) kansellasie van 'n registrasie (die perseel, indien anders as voorgaande, of wat laat vaar word vir verskuiwing) en/of nagesoek deur wie (volle naam); (6) besware aan en tydperk waarbinne.

LIVESTOCK AND MEAT INDUSTRIES CONTROL BOARD

Any person who has any objection against the establishment, transfer or removal of the business mentioned or the cancellation of a registration, may lodge such objection in the form of an affidavit, in triplicate, with the Board's office as indicated and within the period stated.

The information, where applicable, is given in the following order: (1) Township or district, division, county; (2) applicant; (3) kind of application (new registration, transfer, removal) and kind of business; (4) details of premises or place (description, number, situation and/or address); (5) cancellation of a registration (the premises, if other than the preceding, or quitted for removal) and/or by whom (full name); (6) objections to, and period within which.

TRANSVAAL

Potgietersrus. (2) Cornelia Catharina Lewies namens Shaya Taful B.K. (Reg. No. CK 86/00065/23). (3) Nuwe aansoek, slagter. (4) Gedeelte 7 (Gedeelte van Gedeelte 3) van die plaas Rondeboschje 295, K.R., distrik Potgietersrus. (5)—. (6) Hoofbestuurder, Posbus 40051, Arcadia, 0007, 14 dae.

Potgietersrus. (2) Cornelia Catharina Lewies namens maatskappy gestig te word. (3) Nuwe aansoek, afvalhandelaar. (4) Rabestraat 41, Erf 6088, Potgietersrus. (5)—. (6) Hoofbestuurder, Posbus 40051, Arcadia, 0007, 14 dae.

Atteridgeville. (2) David Malatjie. (3) New application, butcher. (4) Stand 7042, Seeiso Street, Atteridgeville, 0008. (5)—. (6) General Manager, P.O. Box 40051, Arcadia, 0007, 14 days.

Vaalbank, distrik Mdotjana. (2) Somazwe Jonas Mabena. (3) Nuwe aansoek, slagter. (4) Libangeni Sakesentrum, Vaalbank, distrik Mdotjana. (5)—. (6) Hoofbestuurder, Posbus 40051, Arcadia, 0007, 14 dae.

KAAP • CAPE

Brackenfell. (2) African European International Trade Co. (Pty) Ltd. (3) Nuwe aansoek, slagter. (4) Erf 2948, Vibenlaan, Industriële Gebied, Brackenfell. (5)—. (6) Hoofbestuurder, Posbus 40051, Arcadia, 0007, 14 dae.

Parow. (2) Kypros Marouchos and Andrew Marouchos. (3) New application, butcher. (4) Shop 3 (b), Erf 1560, corner of Briardene Road and Clarendon Street, Parow Valley, Cape Town. (5)—. (6) Branch Manager, P.O. Box 96, Maitland, 7405, 14 days.

Asherville, Graaff-Reinet. (2) Albert Jacobs as member for Help Enterprises CC. (3) New application, butcher. (4) Corner of Pansy and Asher Streets, Asherville, Graaff-Reinet. (5)—. (6) General Manager, P.O. Box 40051, Arcadia, 0007, 14 days.

Hopefield. (2) Anna-Marie van der List, slagter. (4) Erf 138, 14a Voortrekkerstraat, Hopefield, 7355. (5)—. (6) Hoofbestuurder, Posbus 40051, Arcadia, 0007, 14 dae.

Athlone. (2) Joy's Trading Stores (Pty) Ltd. *Directors:* G. Parker, A. W. Ahmed, L. A. Parker, Z. H. Parker, Y. A. Ahmed and M. A. Amien. (3) New application, butcher. (4) Erf 108871, Maslamoney Avenue, Athlone Industria 2, Cape Town. (5)—. (6) Branch Manager, P.O. Box 96, Maitland, 7405, 14 days.

NATAL

Durban. (2) Osman Sabi. (3) New application, butcher, offal dealer. (4) 81 Albert Street, Durban, 4001, (Block 39-40 H H Townlands, Durban). (5)—. (6) Branch Manager, P.O. Box 2246, Durban, 4000, 14 days.

Umkomaas. (2) Andreas Michaelides. (3) New application, butcher. (4) 10 Reynolds Street, Umkomaas, 4170. (5)—. (6) General Manager, P.O. Box 40051, Arcadia, 0007, 14 days.

ORANJE-VRYSTAAT • ORANGE FREE STATE

Bothaville. (2) Okamang Benjamin Phase, Id. No. 2137848, gebore 21/8/38. (3) Nuwe aansoek, afvalhandelaar. (4) Perseel 3151, Kgotsong, Bothaville, distrik Bothaville. (5)—. (6) Hoofbestuurder, Posbus 40051, Arcadia, 0007, 14 dae.

ALGEMEEN • GENERAL

TRANSVAAL

A. V. HAMMAN TRUST, PRETORIA

INSOLVENTE BOEDEL CHRISTIAAN HATTINGH, MEESTERSVERWYSINGSNOMMER T 1431/87

KENNISGEWING IN TERME VAN ARTIKEL 21 (3) VAN DIE INSOLVENTEWET No. 24/1936 SOOS GEWYSIG

Hiermee word in terme van artikel 21 (3) van die Insolvensiewet, No. 24 van 1936 kennis gegee dat, Anton Victor Hamman, in sy hoedanigheid as kurator van die Insolvente Boedel van **Christiaan Hattingh, T1431/78**, van voorneme is om die volgende bates wat oënskynlik die eiendom van Mevrou Catharina Johanna Hattingh, gebore 12 Augustus 1950, getroud buite gemeenskap van goedere met die Insolvent, te verkoop, die bates synde:

- (1) Erf 92, Lyttleton Landbou Hoewes, ook bekend as Jeanlaan 241, Lyttleton Landbouhoewes, met verbetering daarop.
- (2) Motorvoertuie,
- (3) Meublement,

Enige krediteur van die genoemde Catharina Johanna Hattingh kan hulle eise teen haar boedel in stuur in terme van Artikel 21 (5) van die Insolvensiewet.

Eise moet so gou as moontlik na Posbus 13948, Sinoville, 0129, aangestuur word.

Die Uwe, A. V. Hamman Trust.

Anton Victor Hamman, B. Comm. (Rek.), IRT (S.A.), IAT (S.A.), Lid van Suid-Afrikaanse Assosiasie van Insolvensiepraktisyne, Posbus 13948, Sinoville, 0129; Vierde Verdieping, Pieter Neethlinggebou, Sentraalstraat, Pretoria, 0002. Tel: (012) 26-2924. Na ure: (012) 57-2146.

WESTRUST (PTY) LTD, CK 86/04034/23

NOTICE IN TERMS OF SECTION 21 (3) OF THE INSOLVENCY ACT

Notice is hereby given to Mrs M. Burger, of 2b Delius Street, Vanderbijlpark, that I the undersigned, Neil Bowman, being the Trustee of Insolvent Estate **S. J. Burger**, intend disposing of Erf 154, registered in the name of Mrs M. Burger, after the expiry of six weeks from date hereof.

This notice is given in terms of Section 21 of the Insolvency Act and all separate creditors for value of Mrs M. Burger, are invited to prove their claims in terms of Section 21 (5) of the Act.

Neil Bowman, P.O. Box 10527, Johannesburg, 2000.

Westrust (Pty) Ltd, CK 86/04034/23, Eighth Floor, Wesbank House, 222 Smit Street, Johannesburg, 2001; P.O. Box 10527, Johannesburg, 2000. Telephone 725-3464. Telex 4-24192 SA, Fax 725-6323.

AANSOEK KRAGTENS ARTIKEL 21 (1) VAN DIE WET OP HUWELIKSGOEDERE, WET 88 VAN 1984

WYSIGING VAN HUWELIKSGOEDEREBEDELING

Geliewe kennis te neem dat **Jacobus Lukas Martinus Labuschagne** en **Maria Magdalena Labuschagne**, gebore Haasboek, partye getroud met mekaar binne gemeenskap van goedere op 13 Desember 1958 te Ottoshoop, Marico, welke partye tans woonagtig is te Barnardlaan 2, Rustenburg, Transvaal, van voorneme is om op Donderdag, 29 Oktober 1987 om 10h00 aansoek te doen by die Hooggeregshof van Suid-Afrika, Transvaalse Provinsiale Afdeling, vir wysiging van hul huweliksgoederebedeling na een buite gemeenskap van goedere tussen die partye, met insluiting van die aanwasbedeling.

Geliewe ook kennis te neem dat bogemelde aansoek, asook die voorgename notariële kontrak, tans ter insae lê by die Griffier van die Hooggeregshof, Transvaalse Provinsiale Afdeling asook by Applikant se ondergenoemde prokureurs.

Geliewe voort kennis te neem dat indien beswaar gemaak word of vertoë gerig word teen die voorgename wysiging, partye geregtig is om sodanige besware en/of vertoë skriftelik te maak aan die Griffier van die Hooggeregshof, Privaatsak X60, Pretoria, of persoonlik te verskyn ter bestyding van die aansoek op die dag soos vermeld. 'n Afskrif van enige beswaar of vertoë moet ook gestuur word aan Applikante se ondergenoemde prokureurs.

(Get.) C. M. Weiss, Van der Walt-Weiss, Posbus 334, Rustenburg, 0300.

Datum: 23/9/87.

Verwysing: C. M. Weiss.

KAAP • CAPE**NOTICE**

Take notice that **Margaret Dorothy Harvey** and **Lawrence Frederick Harvey**, of 3 Millwood Corner, Tenth Avenue, Walmer, Port Elizabeth, will make Application to the Supreme Court of South Africa (South Eastern Cape Local Division) on Wednesday, 11th November 1987 at 9.30 a.m., or as soon thereafter as the matter may be heard for an Order in terms of Section 21 (1) of the Matrimonial Property Act No. 88 of 1984, changing their matrimonial property system from in community of property to out of community of property and authorising them to execute a Notarial Contract regulating their future matrimonial property system.

Take notice further that the Application and the Notarial Contract are available for inspection at the office of the registrar of the Supreme Court of South Africa (South Eastern Cape Local Division) and at the offices of the Applicants' Attorneys.

Take notice further that any person who wishes to object to the proposed change, or to make any representations in that regard, may do so in writing to the Registrar of the Supreme Court and by sending a copy of such objection or representations to the Applicants' Attorneys at the address furnished below, or by appearing in Court on the day of the hearing.

Pagdens, Applicants' Attorneys, Nedbank Centre, 88 Main Street, Port Elizabeth; P.O. Box 132, Port Elizabeth (Mr. D. C. Geard/SAW).

NOTICE**SIDNEY BENSOHN, ROB STIRRAT & CHARLES BAILLIE OF R.C.S. PARTNERSHIP**

We, Sidney Bensohn, Rob Stirrat & Charles Baillie of R.C.S. Partnership, 363 Victoria Road, Salt River, 7925, hereby give notice that in consequence of change of ownership we have applied under Regulation 6 of the Registration of Ships Regulations in respect of the ship "Condor" of Hout Bay, Official Number HT22BT, of gross tonnage 13,55 tons, hereto owned by S. Bensohn, 14 Ocean View Drive, Green Point, 8001, R. Stirrat, 3 Torbay Road, Green Point, 8001, C. Baillie, Athol, Bishops Court Drive, Newlands, for permission to change her name to "Falcon".

Any objections to the proposed change of name must be sent to the Director General Transport, Pretoria, within thirty days from the appearance of this notice.

NATAL**CANDIDA FOOTWEAR MANUFACTURERS (PROPRIETARY) LIMITED**

IN PROVISIONAL LIQUIDATION, MASTER'S REF. No. N283/87

NOTICE CONVENING MEETING OF CREDITORS

1. Creditors of Candida Footwear Manufacturers (Proprietary) Limited (in provisional liquidation) ("the company") are hereby notified that in terms of an order of the Supreme Court, Durban and Coast Local Division dated the 30th September 1987, separate meetings of the preferent and concurrent creditors of the company will be held at the offices of Arthur Young Trust and Management Company (Natal) (Proprietary) Limited at 20th Floor, 320 West Street, Durban, on the 30th October 1987 at the following times:

Preferent creditors at 10.15 a.m.

Concurrent creditors at 10.30 a.m.

2. The purpose of the meetings is to consider the proposed compromise (in terms of Section 311 of the Companies Act 61 of 1973 as amended ("the Act")) between the company and its preferent and concurrent creditors, proposed by Joneve in terms of Part I of the document accompanying its letter to the Provisional Liquidator of the company dated the 18th August 1987, and of deciding whether to agree thereto with or without modification.

3. A copy of the statement in terms of Section 312 (1) of the Act may be obtained free of charge on request by any preferent or concurrent creditor of the company at the aforesaid offices of Arthur Young Trust and Management Company (Natal) (Proprietary) Limited.

4. Notice of the said meetings has also been posted by registered post to creditors of the company accompanied by copies of the said statement, the said order of Court, the letter referred to in paragraph 2 above, the document accompanying such letter, certain agreements linked with the proposed compromise and a form of proxy. Copies of all the abovementioned documents as also a list of the creditors of the company may also be obtained by the creditors free of charge at the offices of Arthur Young Trust and Management Company (Natal) (Proprietary) Limited aforesaid.

5. Lloyd Edward Spendiff, the Provisional Liquidator of the company, of Arthur Young Trust and Management Company (Natal) (Proprietary) Limited (at the address aforesaid) has been appointed as Chairman of each separate meeting of the said creditors.

6. If the requisite majorities of creditors required by Section 311 (2) of the Act agree to the proposed compromise, application will be made to the Supreme Court, Durban and Coast Local Division, on Friday the 20th November 1987 at 9.30 a.m. or as soon thereafter as the matter may be heard for the Court's Sanction of the compromise, and for an order discharging the provisional liquidation of the company.

7. A copy of the Chairman's report to the Court will be available to any creditor on request at least one week before the 20th November 1987.

8. Creditors are particularly requested to note:

(a) A creditor intending to vote at any meeting in person or by proxy is required to lodge with the chairman of such meeting, not later than forty-eight hours before the time at which it is to be held, a written statement of the amount of his claim and as to whether it is preferent or concurrent.

(b) The further provisions contained in Part III of the compromise document referred to in paragraph 2 above relating to the voting at the meetings of creditors.

Provisional Liquidator: L. E. Spendiff, Arthur Young Trust and Management Company (Natal) (Proprietary) Limited, 20th Floor, 320 West Street, Durban.

Case 5952/87

IN THE SUPREME COURT OF SOUTH AFRICA
(Durban and Coast Local Division)

Ex parte: **Clarie Isabella Elizabetha Alletha Jordaan**, First Applicant, **Baren Frederick Jordaan**, Second Applicant

IN THE MATTER OF AN APPLICATION FOR THE VARIATION OF THE MATRIMONIAL REGIME

NOTICE OF AN APPLICATION TO COURT IN TERMS OF SECTION 21 (1) OF THE MATRIMONIAL PROPERTY ACT, ACT No. 88 OF 1984

Be pleased to take notice that the abovementioned Applicants intend applying to the Supreme Court of South Africa, Durban and Coast Local Division, Masonic Grove, Durban at 09h30 or as soon thereafter as their Counsel may be heard on Monday, 30th November 1987 for leave to change their matrimonial property regime from one in community to one out of community of property with the application of the accrual system.

Anyone who wishes to object to the proposed change or to make any representation in that regard must do so in writing to the Registrar of the Court and must forward a copy thereof to the Applicants' attorney or should appear in Court on the day of the hearing.

Be pleased to take notice further that a copy of the aforesaid application and a contract which it is proposed to register, are available for inspection at the office of the Registrar of the Court and the office of the Applicants' attorneys.

Dated at Durban this 5th day of October 1987.

Chennells Albertyn, Applicant's Attorneys, 1101 Salmon Grove Chambers, 407 Smith Street, Durban. Our Ref: S. Pillay (Tel. 304-6603).

AANSOEKE OM REGISTRASIE VAN HANDELSMERKE IN SUIDWES-AFRIKA

(Aansoeke aangeneem ingevolge Wet 48 van 1973)

Enigiemand wat beswaar het teen enige van die onderstaande handelsmerke kan, binne die voorgeskrewe tydperk op vorm SM 6, vervat in die Tweede Bylae van die Handelsmerke-regulasies in Suidwes-Afrika, 1973, Kennisgewing van Beswaar indien. Die voorgeskrewe tydperk is twee maande na die datum van advertensie. Hierdie tydperk kan op aansoek deur die Registrateur verleng word.

Formele beswaar moet nie ingedien word voordat die applikant om registrasie per brief van die beswaar in kennis gestel is nie, ten einde hom in die geleentheid te stel om sy aansoek terug te trek voordat onkoste in verband met die opstel van 'n Kennisgewing van Beswaar aangegaan word. By gebreke van so 'n kennisgewing aan die applikant, kan koste teen die beswaarmaker uitgewys word.

"B" voor die nommer dui aan Deel B van die Handelsmerkregister.

REGISTRATEUR VAN HANDELSMERKE VIR SUIDWES-AFRIKA

APPLICATIONS FOR REGISTRATION OF TRADE MARKS IN SOUTH WEST AFRICA

(Applications accepted in terms of Act 48 of 1973)

Any person who has grounds for objection to any of the following trade marks may, within the prescribed time, lodge Notice of Opposition on form SM 6 contained in the Second Schedule to the Trade Marks Rules in South West Africa, 1973. The prescribed time is two months after the date of advertisement. This period may on application be extended by the Registrar.

Formal opposition should not be lodged until after notice has been given by letter to the applicant for registration so as to afford him an opportunity of withdrawing his application before the expense of preparing the Notice of Opposition is incurred. Failing such notice to the applicant an opponent may not succeed in obtaining an order for costs.

"B" preceding the number indicates Part B of the Trade Mark Register.

REGISTRAR OF TRADE MARKS FOR SOUTH WEST AFRICA

CLASS 21

87/0068(SWA) in Class 21: Small domestic utensils and containers (not of precious metal or coated therewith) including basins, buckets, boxes, bottles, platters, cans, cups, flasks, jars and jugs; cooking utensils including pots and pans of all kinds; combs and sponges; brushes (other than paint brushes); brushmaking materials; instruments and material for cleaning purposes; steelwool; unworked or semi-worked glass (excluding glass used in building); glassware, porcelain and earthenware not included in other classes; in the name of MARCTIME (PTY) LIMITED, a South African company of 214 Southern Life Centre, 8 Riebeeck Street, CAPE TOWN, 8001. Address for service: Messrs. John & Kernick, Van der Stel Building, Pretorius Street, PRETORIA.

VACUCLEAR.

Registration of this trade mark shall give no right to the exclusive use of the word separately and apart from the mark.

Applicants admit that registration of this trade mark shall not prevent third parties from the bona fide use in the ordinary course of trade of the word VACUUM in its ordinary signification and apart from the mark.

Associated with 87/0067(SWA).

FILED: 29 January 1987.

CLASS 21

87/0067(SWA) in Class 21: Small domestic utensils and containers (not of precious metal or coated therewith) including basins, buckets, boxes, bottles, platters, cans, cups, flasks, jars and jugs; cooking utensils including pots and pans of all kinds; combs and sponges; brushes (other than paint brushes); brushmaking materials; instruments and material for cleaning purposes; steelwool; unworked or semi-worked glass (excluding glass used in building); glassware, porcelain and earthenware not included in other classes; in the name of MARCTIME (PTY) LIMITED, a South African company of 214 Southern Life Centre, 8 Riebeeck Street, CAPE TOWN, 8001. Address for service: Messrs. John & Kernick, Van der Stel Building, Pretorius Street, PRETORIA.

VACUFRESH

Registration of this trade mark shall give no right to the exclusive use of the word FRESH separately and apart from the mark.

Applicants admit that registration of this trade mark shall not prevent third parties from the bona fide use in the ordinary course of trade of the word VACUUM in its ordinary signification and apart from the mark.

Associated with 87/0068(SWA)

FILED: 29 January 1987.

CLASS 41

87/0818(SWA) in Class 41: Education and entertainment; in the name of SUN INTERNATIONAL LIMITED, a South African company of 123 Rivonia Road, Sandown, Sandton, Transvaal, Republic of South Africa. Address for service: Messrs. Adams & Adams, Benstra Building, 473b Church Street, Arcadia, PRETORIA.

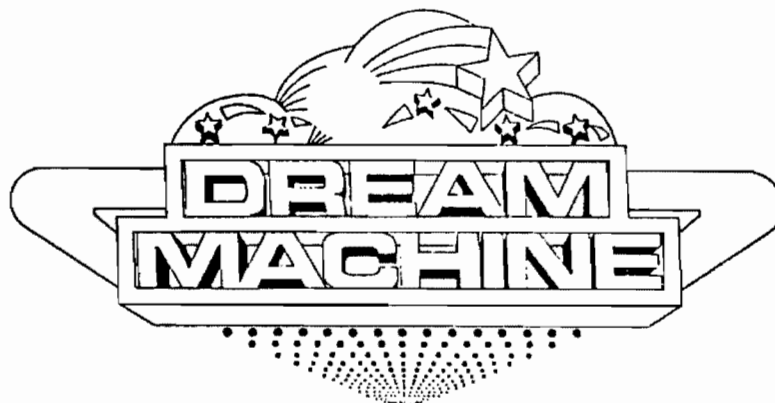

Associated with 87/0307(SWA).
FILED: 11 June 1987.

CLASS 9

84/0256(SWA) in Class 9: Motion picture films, videotapes, videocassettes, videodiscs; records, tapes and cassettes for reproducing sound; other media for recording and reproducing sound and visual images; in the name of MGM/UA ENTERTAINMENT CO., a corporation organised under the laws of the State of Delaware of 10202 West Washington Blvd., Culver City, California 90230, United States of America. Address for service: Messrs. Adams & Adams, Benstra Building, 473b Church Street, Arcadia, PRETORIA.



Associated with 2139/50(SWA).
FILED: 4 April 1984.

PHYTOPHYLACTICA

Hierdie publikasie bevat artikels oor plantpatologie, mikologie, mikrobiologie, entomologie, nematologie en ander dierkundige plantplae. Vier dele van die tydskrif word per jaar gepubliseer.

Verdienstelike landboukundige bydraes van oorspronklike wetenskaplike navorsing word vir plasing in hierdie tydskrif verwelkom. Voorskrifte vir die opstel van sulke bydraes is verkrygbaar van die Direkteur, Landbou-inligting, Privaatsak X144, Pretoria, aan wie ook alle navrae in verband met die tydskrif gerig moet word.

Die tydskrif is verkrygbaar van bogenoemde adres teen R5 plus AVB per eksemplaar of R20 per jaar, posvry (Buitelands R6,25 per eksemplaar of R25 per jaar).

PHYTOPHYLACTICA

This publication deals with plant pathology, mycology, microbiology, entomology, nematology, and other zoological plant pests. Four parts of the journal are published annually.

Contributions of scientific merit on agricultural research are invited for publication in this journal. Directions for the preparation of such contributions are obtainable from the Director, Agricultural Information, Private Bag X144, Pretoria, to whom all communications in connection with the journal should be addressed.

The journal is obtainable from the above-mentioned address at R5 plus GST per copy or R20 per annum, post free (Other countries R6,25 per copy or R25 per annum).

BOEDELWETTEKENNISGEWINGS ADMINISTRATION OF ESTATES ACTS NOTICES

Vorm/Form J 297

VERKIESING VAN EKSEKUTEURS, KURATORS EN VOOGDE

Aangesien die boedels van die persone hieronder vermeld nie verteenwoordig is nie, word hierby deur Meesters van die Hooggeregshof van Suid-Afrika aan belanghebbendes kennis gegee dat byeenkomste ten opsigte van die verskillende boedels op die plekke, datums en tye vermeld, gehou sal word, met die doel om 'n persoon of persone te kies vir goedkeuring deur die onderskeie Meesters as geskik en bekwaam om deur hulle aangestel te word as eksekuteurs, kurators of voogde, na gelang van omstandighede, met aanduiding van die besonderhede in die volgorde: Boedelnommer, familie-naam en voorname van oorlede persoon, en beroep; datum van oorlye; plek, datum en tyd van byeenkoms.

In 'n plek waarin 'n kantoor van 'n Meester is, word die byeenkoms voor die Meester gehou en in ander plekke voor die Landdros.

L.W.—Items aan die linkerkant met 'n sterretjie (*) gemerk, dui aan die verkiesing van 'n voog of kurator; andersins word 'n eksekuteur gekies.

ELECTION OF EXECUTORS, CURATORS AND TUTORS

The estates of the persons mentioned below being unrepresented, interested parties are hereby given notice by Masters of the Supreme Court of South Africa, that meetings will be held in the several estates at the places, dates and times specified, for the purpose of selecting some person or persons for approval by the respective Masters, as fit and proper to be appointed by them as executors, curators and tutors, as the case may be, indicating the particulars as follows: Estate number, surname and christian names of deceased, and occupation; date of death; place, date and time of meeting.

Meetings in a place in which there is a Master's Office, will be held before the Master; elsewhere they will be held before the Magistrate.

N.B.—Items indicated by an asterisk (*) on the left-hand side denote the election of a tutor or curator; otherwise an executor is to be elected.

TRANSVAAL

*16814/85 en 16815/85—**Van Zyl**, Maria Magdalena en Casper Hendrik Badenhorst van Zyl, klerk. 15/11/85. Pretoria, 19/10/87, 09h00.
14357/76/ASR3—**Smith**, Jack, mynwerker. 29/10/76. Fochville, 20/10/87, 14h00.

KAAP • CAPE

5812/50—**Fourie**, Amelia Elizabeth, boer (eggenoot). 24/9/50. George, 30/10/87, 10h00.
65519—**Wooten**, Herbert Edward, farmer. 14/7/39. Port Elizabeth, 29/10/87, 14h00.
823/81—**Van Schalkwyk**, Lionel William, clerk. 31/12/80. Cape Town, 27/10/87, 09h00.

Vorm/Form J 295

KURATORS EN VOOGDE: MEESTERS SE KENNISGEWINGS

Ingevolge artikel 75 van Wet 66 van 1965, word hierby kennis gegee van die aanstelling van persone as kurators of voogde deur Meesters, of van die beëindiging van aanstellings in sodanige hoedanighede.

Die inligting word verstrek in die volgorde: Nommer van saak; persoon onder kuratele, of minderjarige, en adres; naam en adres van kurator of voog; of aanstelling of beëindiging daarvan, en datum; Meester van die Hooggeregshof.

CURATORS AND TUTORS: MASTERS' NOTICES

In terms of section 75 of Act 66 of 1965, notice is hereby given of appointments of persons as curators or tutors by Masters, or of their having ceased in their respective capacity.

The information is given in the following order: Number of matter; person under curatorship, or minor, and address; name and address of curator or tutor; whether appointment or cease in capacity, and date; Master of the Supreme Court.

KAAP • CAPE

2773/87—**Howes**, Leonard Clifford, 23 The Avenue, University Estate, Woodstock. Curator/Tutor, Margaret Howes, c/o Arthur E. Abrahams & Gross, 2 Long Street, Cape Town. Appointment, 11 August 1987.

Case 10424/86

IN THE SUPREME COURT OF SOUTH AFRICA (Cape of Good Hope Provincial Division)

In the matter between **Hoosain Jano**, Applicant, and **Hassan Jano**, Respondent

NOTICE IN TERMS OF THE PROVISIONS OF SECTION 75 OF ACT 66 OF 1965

Take notice that a Curator has been appointed to the Estate of Hassan Jano of 8 Thornwick Road, Plumstead.

The Curator is Gerald Ivor Osrin of Maynard House, Maynard Road, Wynberg.

Dated at Claremont on this 29th day of September 1987.

Pincus-Matz—Marquard Hugo-Hamman, Per: (Attorneys for the Curator), 135 Main Road, Claremont.

2152/83—**Erskine**, Rupert Alexander, The Auld House, Swellendam, 6740. Curator/Tutor, Colin John Wagner, c/o Syfrets Trust Ltd, 24 Wale Street, Cape Town. Cease, 17 June 1987.

Notice is hereby given, in terms of section 5 (2) of the Insolvency Act 24 of 1936 (as amended), that it is intended to apply to the Master of the Supreme Court to appoint a Curator Bonis in the matter of: **Henry John Hendricks**, Identity Number 3312245096017, of 6 21st Avenue, Elsies River, Cape.

S. Gutman, Group Administrators & Trustees (Pty) Ltd, Third Floor, Standard Bank ABC Building, 130 Adderley Street, Cape Town, 8001.

Vorm/Form J 193

KENNISGEWING AAN KREDITEURE IN BESTORWE BOEDELS

Alle persone wat vorderinge het teen die boedels hieronder vermeld, word hierby versoek om hul vorderinge by die betrokke eksekuteurs en binne 'n tydperk van 30 dae (of andersins soos aangedui) gereken vanaf die datum van publikasie hiervan in te lewer. Die inligting word verstrek in die volgorde: Boedelnummer, familienaam en voorname, geboortedatum, persoonsnommer, laaste adres, datum oorlede; nagelate eggenoot(note) se name, familienaam, geboortedatum en persoonsnommer; naam en adres van eksekuteurs of gemagtigde agent, tydperk toegelaat vir lewering van vorderings indien anders as 30 dae.

NOTICE TO CREDITORS IN DECEASED ESTATES

All persons having claims against the estates mentioned below are hereby called upon to lodge their claims with the executors concerned, within 30 days (or otherwise as indicated) calculated from the date of publication hereof. The information is given in the following order: Estate number, surname and christian names, date of birth, identity number, last address, date of death; surviving spouse's names, surname, date of birth and identity number; name and address of executor or authorised agent, period allowed for lodgement of claims if other than 30 days.

TRANSVAAL

9376/87—**Van Wyk**, Michael Anthonie, 4/11/05, 0511045003007, Huis Blymoedig, Geriatriese Kliniek, Pretoria, 25/6/87. Eerste Nasionale Bank Bpk., Posbus 1714, Bloemfontein.

12502/87—**Blackstock**, George McKenzie, 4 June 1906, 0606045022005, 21 Station Road, Brakpan, 7 August 1987; Thelma Peggy Blackstock, 15 April 1911, 1104150014008. Trollip, Cowling & Janeke, P.O. Box 38, Brakpan.

12256/87—**Maggio**, Ethel Violet, 5/5/23, 2305050076000, 526 Rachel de Beer Street, Pretoria North, 21/8/87. Lunnon & Tindall, P.O. Box 400, Pretoria.

12271/87—**Smit**, Jan, 1104215026005, Fouchestraat, Swaruggens, 12 Augustus 1987. Volkskastrust Bpk., Posbus 970, Klerksdorp.

10264/87—**Van Metzinger**, Willem Anthonie, 21/12/1899, 9912245011009, Rehnoterspruit, Muldersdrift, distrik Krugersdorp, 21 Julie 1987. J. B. Hugo & Cronje, Posbus 115, Krugersdorp.

10347/87—**Smith**, Andrew Johannes, 13 Junie 1946, 4606135059004, Mowbrauweg 9, Greenside, Johannesburg, 12 Julie 1987. Kriek & Van Noordwyk, Posbus 953, Johannesburg.

3912/86—**Ciceri**, Roberto Alessandro Silvano, 1947-03-17, 4703175164107, 55 Pyramid Road, Edenglen, Edenvale, 1985-07-10. Malherbe, Rigg & Ranwell, P.O. Box 186, Boksburg.

Mtiya, Nocabango Winnie, 2771278, 11052 Orlando West Extension, Soweto, 12 May 1987. Arthur Mzimkhulu Nonyongo, 315-317 York House, 57 Rissik Street, Johannesburg.

14955/86—**Miller**, Willem Jacobus, 25 Desember 1959, 5912255111008, Posbus 7139, Hennopsmeer, 8 November 1986. A. J. van Deventer, Grond Verdieping, Jancorgebou, Burgerstraat 295, Pretoria-Noord.

10981/87—**Nel**, Jan Jacobus, 18 April 1923, 2304185005000, Hoewe 53, Lakeside, Rex, Waterkloof, Rustenburg, 6 Julie 1987. Van der Walt-Weiss, Posbus 334, Rustenburg.

9108/87—**Altenkirk**, Mary Leslie, 11/7/01, 0107110022004, Koppiefontein 42, District of Pietersburg, 9/6/87. Meyer Pratt & Luyt, P.O. Box 152, Pietersburg.

12370/87—**Jegels**, Norman, 5 November 1950, 5011055150010, 1614 Cecil Flat, Westbury, Newclare, 10 February 1987; Hendrika Jegels, 23 August 1948, 4808230149017. Stabilitas Board of Executors (Pty) Ltd, P.O. Box 11509, Johannesburg.

11672/87—**Human**, Phyllis, 7 August 1902, 158 President Steyn Street, Louis Trichardt, 17 December 1986. Coxwell & Steyn, P.O. Box 52, Louis Trichardt.

11852/87—**Van der Merwe**, Pieter Hendrik, 11 April 1941, 4104115047009, Rietfontein, Koster, 23 Augustus 1987; Maria Elizabeth van der Merwe, 14 Desember 1941, 4112140017087. Coetzee & Van der Merwe, Posbus 12, Wolmaransstad.

12666/87—**Ebersohn**, Martha Maria, gebore Claassens, 3 Augustus 1915, 1508030032008, Blakestraat 80, Riviera, Pretoria, 30 Augustus 1987. Kellerman Nel & Bruni, Posbus 466, Pretoria.

11954/87—**Rainier**, Thora Edna, 12 Desember 1912, 1212120030002, 6 Olifantsvlei, Johannesburg, 16 August 1987. Geo. Isserow & T. L. Friedman, 546 Jules Street, Malvern, Johannesburg.

7177/87—**Klopper**, Anna Sophia Maria, 5 April 1914, 1404050002008, Valleifontein, Posbus 25, Rooigrond, 24 Mei 1987. Minchin & Kelly, Posbus 26, Mafikeng.

11472/87—**McIldowie**, Robert, 24/9/42, 4209245144102, 197 Corlett Drive, Bramley, Johannesburg, 29/7/87. M. J. Shneier, P.O. Box 528, Benoni.

12207/87—**Van der Walt**, Dorothea Regina Jacomina, 24 Junie 1919, 1906240016003, Rietspruit 24, Ellisras, 30 Augustus 1987. Gys Vlok & Els, Posbus 117, Ellisras.

8670/87—**Van Waart**, Wilhelmina Georgina, gebore Schlünz, 30 November 1895, 9511300001002, weduwee, Nebohof 310, Troyestraat 35, Sunnyside, Pretoria, 26 Junie 1987. Vorster & Robbertse, Posbus 50, Piet Retief.

12459/87—**Macaulay**, Duncan, 29/11/12, 1211295036000, 58 Main Avenue, Springs Extension, Springs, 16/8/87. Charles Sherman Levin & Prosser Inc., P.O. Box 886, Springs.

11828/87—**Verster**, Marthinus Willem Adriaan, 8 April 1924, 2404085006007, Jeppelaan 385, Clewer, distrik Witbank, 21 Augustus 1987. Brandmuller, V. d. Berg & Verster, Posbus 59, Middelburg.

10339/87—**Janse van Rensburg**, Margaret Thompson (Thomson), 1920-10-06, 2010060030001, Ferreirastraat 7, Nelspruit, 1987-07-07.

12930/86—**Fourie**, Elizabeth Johanna Gezina, 10/2/06, 20602100045005, Blymoedig Geriatriese Kliniek, Pretoria, 25/5/86. Herlu Smith, Posbus 378, Bronkhorstspruit.

7064/87—**Botha**, Marthinus Christoffel, 22 Februarie 1944, 4402225057003, Schubartparkwoonstelle 1810, Blok A, Potgieterstraat, Pretoria, 5 Mei 1987. André G. Smuts, Posbus 743, Brakpan.

6582/87—**Dias**, Rui Manuel Serra Farinha, 27 May 1941, 407 Granada Flats, Hillbrow, Johannesburg, 22 May 1987. Rorich Wolmarans & Luderitz Inc., P.O. Box 2330, Pretoria.

10962/87—**Mienie**, Charl Johannes Hendrik, 5/5/09, 0905055025001, Perseel J64, Marble Hall, distrik Groblersdal, 28 Julie 1987; Sophia Ferdinandina Mienie, gebore Pohl, 2/7/22, 2207020014006. De Beer, Goosen & Kie., Posbus 330, Marble Hall.

12151/87—**Lottering**, Johannes Marthinus, 2 Oktober 1914, 1410025007006, Rabéstraat 215, Potgietersrus, 30 Augustus 1987; Gertruida Magrietha Sophia Lottering, 12 November 1919, 1911120002008. Borman, Snyman & Barnard, Posbus 42, Potgietersrus.

11810/87—**De Villiers**, Elizabeth Cornelia, 10/4/10, 1004100071001, Woonstel 20, Huis Delarey, Delareyville, 16/8/87. De Kock & Duffey, Posbus 37, Schweizer-Reneke.

- 13331/86—**Wright**, Victor Leon, 2 February 1929, 2902025066007, 99 Kelvin Power Station, Kempton Park, 11 July 1986; Dawn Villars Wright, 25 May 1937, 3705250073005. Piet Smith & Co., P.O. Box 22, Venterstad.
- 2742/87—**Tarmohamed**, Joosub Abdullah, 1940-09-16, 4009165089050, Delhistaat 24, Nirvana, Pietersburg, 1987-02-15. F. D. Cahill, Posbus 32, Brits.
- 8950/87—**Pender**, Louisa, 17 December 1902, 0212170020003, Fairhaven Old Age Home, Main Street, Johannesburg, 27 June 1987. M. Dingle, P.O. Box 17108, Pretoria North.
- 7600/87—**Boshoff**, Phoebe Maria, 5/2/36, 3602050003003, Harveystraat 38, Luipaardsvlei, 14 Mei 1987; Hendrik Petrus Boshoff, 28/11/23, 2311285011002. H. P. Boshoff, Posbus 3215, Kenmare.
- 3642/87—**Pillay**, Somasundram, 23/5/24, 800008598A, 367 Indigo Street, Laudium, Pretoria, 6/2/87; Sarah Pillay, 007981476C. F. Saint, Gani & Associated, 513 Olivetti House, corner Pretorius & Schubart Streets, Pretoria.
- 10481/87—**Deysel**, Catharina Magdalena, 3710160019007, Demiststraat 12, Stilfontein, distrik Klerksdorp, 26 Julie 1987; Jan Frederick Deysel, 3710025029001. Volkskastrust Bpk., Posbus 970, Klerksdorp.
- 11782/87—**Pieterse**, Pieter Willem Adriaan, 2208095016009, Gesinastraat 30, Oberholzer, 5 Julie 1987. Volkskastrust Bpk., Posbus 970, Klerksdorp.
- 12607/87—**Du Toit**, Antonie Gerhardus, 17 September 1917, 1709175027007, Groenwilgers Woonstelle 5, Meulstraat 17, Potchefstroom, 24 Augustus 1987. Volkskastrust Bpk., Posbus 970, Klerksdorp.
- 12364/87—**Fenn**, Christina Johanna Elizabeth, 18 Oktober 1928, 2810180061004, Wichtstraat 11, Brits, 22 Augustus 1987. E. D. Ras & Kie, Posbus 5, Brits.
- 10782/87—**Cairolì**, Enrico, 12/7/08, 0807125027100, 60 Village Road, Farrarmere, Benoni, 22 July 1987. Gilchrist & Reid, P. O. Box 356, Benoni.
- 11912/87—**Opperman**, Christian Rudolph, 10 Junie 1933, 3306105029001, Rikkie Postmastraat 15, Vanderbijlpark, 30 Julie 1987. Volkskastrust Bpk., Posbus 61488 Marshalltown.
- 12373/87—**Jordaan**, Johannes Gotlieb, 5 Desember 1929, 2912055055002, 10de Straat 60, Newlands, 29 Augustus 1987; Hilda Maria Jordaan, 331462780W. Volkskastrust Bpk., Posbus 61488, Marshalltown.
- 12387/87—**Meyer**, Johan George, 22 Mei 1906, 0605225001003, Derde Straat 12, Delarey, 12 Augustus 1987. Volkskastrust Bpk., Posbus 61488, Marshalltown.
- 12594/78—**Scott**, Frederick Puckle, 22 May 1931, 3105225014004, 8 Monmouth Road, Westdene, Johannesburg, 22 August 1987. Volkskastrust Ltd, P.O. Box 61488, Marshalltown.
- 12438/87—**Griesel**, Ernest Lodewyk, 6 November 1928, 2811065035001, Suid-Klipriviersbergweg 100, The Hill, Johannesburg, 24 Augustus 1987; Susanna Maria Griesel, 11 Februarie 1931, 3102110016004. Volkskastrust Bpk., Posbus 61488, Marshalltown.
- 12297/87—**Gentle**, John James, 8 Mei 1913, 1305085003004, Humanstraat 106, Krugersdorp, 18 Augustus 1987; Elsie Petronella Gentle, 2 Oktober 1919, 1910020005004. Volkskastrust Bpk., Posbus 61488, Marshalltown.
- 11817/87—**Van Vuuren**, Philippus Mynhardt, 7 Oktober 1918, 1810075028002, Rowanplace 5, Constantia Kloof, Roodepoort, 4 Augustus 1987. Volkskastrust Bpk., Posbus 61488, Marshalltown.
- 12583/87—**Redelinghuys**, Stephanus Andreas, 8 Januarie 1922, 2201085011007, Ridgelaan 8, Dawnview, Germiston, 16 Augustus 1987; Annie Rebecca Redelinghuys, 22 Augustus 1926, 2608220051005. Volkskastrust Bpk., Posbus 61488, Marshalltown.
- 8274/87—**Uys**, Leon John, 9 November 1961, 6111095068002, Ellis Rylaan, Wright Park, Springs, 6 Maart 1987; Deborah Dianne Uys, 6 Februarie 1965, 6502060129003. D. D. Uys, P/a J. J. van der Watt, Rietfonteinweg 46, Glen Marais, Kemptonpark.
- 8365/87—**Holtzhausen**, Trevor Vernon Meares Tait, 14 September 1949, 4909145073001, Nerinalaan 32, Verwoerdpark, Alberton, 24 Mei 1987; Johannes Helena Holtzhausen, gebore Oschman, 9 November 1945, 4511090057003. Volkskastrust Bpk., Posbus 61488, Marshalltown.
- 12354/87—**Boswell**, Sarah Johanna, 26 April 1924, 2404260019007, Huis 204, Vaalkrag Sentrale, Viljoensdrift, 23 Augustus 1987. Volkskastrust Bpk., Posbus 61488, Marshalltown.
- 8462/87—**Janse van Rensburg**, Anna Elizabeth, 5 September 1940, 4009050075009, Parklandrylaan 142, Estherpark, Kempton Park, 7 Junie 1987; Jacobus Johannes Janse van Vuuren, 1 Mei 1933, 3305015028004. Volkskastrust Bpk., Posbus 61488, Marshalltown.
- 12165/87—**Nel**, Jan Frederik, 24 April 1933, 3304245024008, Wynandweg 20, Glen Marais, Kempton Park, 29 Junie 1987. Botha Massyn & McKenzie, Privaatsak 53, Kempton Park.
- 12464/87—**Mudde**, Karel Jacobus, 17 September 1904, 0409175019101, Stigting A2, Oranjehof, Bonaero Park, Kempton Park, 27 Mei 1987. Botha Massyn & McKenzie, Privaatsak 53, Kempton Park.
- 12233/87—**Farrand**, Eric Austin, 30 September 1907, 0709305043107, 25 Sysie Road, Croydon, 24 August 1987. Botha Massyn & McKenzie, Private Bag 53, Kempton Park.
- 11761/87—**Kotzee**, Petronella Cathrina Gertuida Gesina, 4002270006002, Goedgedacht, Wolmaranstad, 1 Julie 1987; Willem Hendrik Johannes Kotzee, 3703305040004. Volkskastrust Bpk., Posbus 970, Klerksdorp.
- 12130/87—**Hughes**, Ada, 5/11/05, 0511050002001, Elgeda Flats 10, Leslie Street, Vereeniging, 16/8/87. First Personal Asset Management, P.O. Box 1538, Klerksdorp.
- 12013/87—**James**, Mary Elizabeth, 28 January 1918, 1801280007006, 45 Jurgens Avenue, Strubenvale, Springs, 6 August 1987. Clifford St John Wills, P.O. Box 738, Springs.
- 9028/87—**Smith**, Charles John Smit, 30 September 1951, 5109305035002, Van Riebeeckstraat 39, Vereeniging, 3 Julie 1987; Lorraine Louelle Smith, 28 September 1953, 5309280016007. G. J. Fourie & Truter, Posbus 924, Vereeniging.
- 10051/87—**Coetzee**, Adriaan Johannes, 12 November 1924, 2411125054004, 9 Kotze Street, Lodeyko, Springs, 23 March 1987. G. S. Silber, P.O. Box 452, Brakpan.
- 16397/81—**Hiles**, William Henry, 1944-1-6, 4401065056000, Waterbokstraat 19, Bethal, 12 Oktober 1981; Aletta Catharina, 22 September 1943, 4309220066006. Lou van der Merwe & Kie, Posbus 184, Bethal.
- 5343/87—**Palmer**, Mildred, 15/8/21, 13 Egret Streets, Elspark, Germiston, 3/4/87. Palmer's Trust Investments and Estate Administrators Ltd, P.O. Box 135, Durban.
- 12178/87—**Robertson**, Iris Violet, 11/4/11, 1104110041000, 186 De Villiers Street, Kenilworth, Johannesburg, 4/7/87. Ernst & Whinney, P.O. Box 2826, Durban.
- 11480/87—**Taljaard**, Susanna Sophia, 8 Desember 1929, 2912080065000, weduwee, Posbus 142, Delareyville, 7 Augustus 1987. G. J. Marais & Kie, Posbus 452, Delareyville.
- 10300/87—**Coetzee**, Joseph Adriaan, 31/1/13, 1301315028002, Azalia Woonstelle 41, Pretoriusstraat, Arcadia, Pretoria, 17/7/87; Francina Cecilia Catharina Coetzee, 17/12/16, 1612170014006. Volkskastrust Bpk., Posbus 383, Pretoria.
- 8519/87—**De Jager**, Anna Cecilia, 13/6/12, 1206130017009, Frangipanistraat 283, La Montagne, Pretoria, 13 Mei 1987. Volkskastrust Bpk., Posbus 383, Pretoria.
- 12549/87—**Liebenberg**, Hendrina Johanna Barendina, 16 Februarie 1929, 2902160026006, Posbus 1158, Bronkhorstspuit, 22 Augustus 1987; Johannes Petrus Liebenberg, 20 Junie 1925, 2506205049004. Volkskastrust Bpk., Posbus 383, Pretoria.
- 11745/87—**Gelderblom**, Daniel Johannes, 2/7/23, 2307025048007, Presidentstraat 417, Silverton, Pretoria, 17 Julie 1987; Susanna Jacomina Elsie Petronella Gelderblom, gebore Van Wyngaard, 1/5/45, 4505010065005. Volkskastrust Bpk., Posbus 383, Pretoria.
- 12849/87—**Vorster**, Stephanus Johannes Roelof, 8 Junie 1906, 0206085013004, Louis Mansions 701, Troystraat 1, Sunnyside, Pretoria, 20 Augustus 1987; Jeanetha Petronella Vorster, 19 Maart 1908, 0803190018009. Volkskastrust Bpk., Posbus 383, Pretoria.

- 11805/87—**Van Schalkwyk**, Christina Magritha, 11/6/04, 0407110010003, Sesde Laan 112, Thabazimbi, 1 Augustus 1987. Volkskastrust Bpk., Posbus 383, Pretoria.
- 10870/87—**Smith**, Willem Nicolas, 6 Mei 1917, 1705065036009, Commercialstraat 983, Pretoria-Tuine. Volkskastrust Bpk., Posbus 383, Pretoria.
- 12698/87—**Du Plooy**, Carl Frans, 29 Maart 1959, 5903295105001, Merllstraat 6, Eldorette, Akasia, Pretoria-Noord, 9 Augustus 1987. Volkskastrust Bpk., Posbus 383, Pretoria.
- 15612/86—**Frese**, Michael Justin, 15/3/65, 6503155037002, 10 Asgaai Avenue, Randpark Ridge Extension 1, Randburg, 16/8/86. J. A. P. Frese, P.O. Box 77153, Fontainebleau.
- 12562/86—**Maclean**, Mabel Jean, 10080028008, 12 Juno Ridge, Juno Street, Kensington, Johannesburg, 12 September 1986. Handelsman Gibson & Partners, Fourth Floor, The Inner Court, 74 Kerk Street, Johannesburg.
- 12237/87—**Gliori**, Velio, 27 February 1931, 3102275065101, 22 Nottingham Road, Kensington, Johannesburg, 14 August 1987; Sonia Gliori. Routledge-MacCallums, P.O. Box 306, Johannesburg.
- 15762/86—**Shapiro**, Hella, 7 April 1912, 1204070019002, 512 Interlaken, Eighth Street, Killarney, Johannesburg, 13 November 1986. Edward Nathan & Friedland Inc., P.O. Box 3370, Johannesburg.
- 13515/87—**Davids**, Edwin, 19 June 1952, 5206195125015, 49 Athena Street, Ennerdale Extension 1, 15 September 1987; Cynthia Yvonne Cecilia Davids, 24 November 1948. Bertha Pencharz, 222 Yorkshire House, 104 Marshall Street, Johannesburg.
- 10957/87—**Katz**, Sarah (Sally), 8 April 1911, 1104080026007, 26 Hanover Place, Second Avenue, Killarney, Johannesburg, 10 July 1987. Izak Weiner & Co., P.O. Box 28861, Sandringham.
- 12323/87—**Price-Williams**, Glyn, 27 January 1908, 3312878GOW, 10 Hawke Street, Kensington, Johannesburg, 16 August 1987; Veronica Nellie Price-Williams. First Personal Asset Management Company, P.O. Box 2036, Johannesburg.
- 12024/87—**Nesbit**, William Conyers, 2 November 1907, 0711025021009, 8 Niagara Gardens, The Falls, Benoni, 6 August 1987. First Personal Asset Management Company, P.O. Box 2036, Johannesburg.
- 12366/87—**Glass**, Israel Hyman, 2 January 1899, 9901025006008, The Herald, Soper Road, Berea, Johannesburg, 30 June 1987. First Personal Asset Management Company, P.O. Box 2036, Johannesburg.
- 12328/87—**Robertson**, Hester Meiring, 9/7/07, 0707090027004, Rusoord-ouetehuis, Rustenburg, 22/7/87. Volkskastrust Bpk., Posbus 383, Pretoria.
- 11181/87—**Grundling**, Elizabeth Catharina, 10 Januarie 1897, 9701100017007, Sussara-afreeoord, Rauvensklip, Pitoustraat, Boksburg, 5 Julie 1987. Volkskastrust Bpk., Posbus 383, Pretoria.
- 12003/87—**Engelbrecht**, Johan George Michiel, 4/12/30, 3012045009000, 34ste Laan 306, Villieria, Pretoria, 20/8/87; A. Kalie Engelbrecht, 28/11/31, 3111280030000. Volkskastrust Bpk.
- 11490/87—**Dely**, Zolta'n, 1 Augustus 1931, 3108015002007, Vlokstraat 522, Silverton, Pretoria; Matilda Dely, gebore Tasnadi, 23 Desember 1934, 3412230004008. Volkskastrust Bpk., Posbus 383, Pretoria.
- 12167/87—**Nichols**, Jan Christiaan, 5 November 1913, 1311055018006, Maalinwoonstelle 6, Middelburg, 2 Augustus 1987; Anna Susanna Nichols, 16 Julie 1920, 2007160004001. Volkskastrust Bpk., Posbus 383, Pretoria.
- 9547/87—**Muller**, Christoffel Petrus, 3 April 1941, 4104035013008, Union Division Douglas Collieries, Breyten, 22 April 1987. Volkskastrust Bpk., Posbus 383, Pretoria.
- 12175/87—**Du Plooy**, Petrus Albertus, 1 Desember 1926, 2612015021009, A G S Pastorie, Skeerpoort, 10 Julie 1987; Jacomina Elizabeth du Plooy, 26 Julie 1927, 2707260042005. Volkskastrust Bpk., Posbus 383, Pretoria.
- 12357/87—**Burger**, Coenraad Wilhelm, 18 Oktober 1927, 2710185030006, Stubbstraat 45, Louis Trichardt, 15 Augustus 1987; Johanna Fredrieka Wilhelmina Burger, 11 Maart 1935, 3503110029006. Volkskastrust Bpk., Posbus 383, Pretoria.
- 11489/87—**Broekman**, Susanna Josina, 25 Julie 1908, 0807250004007, Huis H. J. Piek, Middelstraat, Muckleneuk, Pretoria, 22 Julie 1987. Volkskastrust Bpk., Posbus 383, Pretoria.
- 11504/87—**Ehlers**, Gertha Johanna, 14 Oktober 1910, 1011140000005, Sederberg 407, Prinsloostraat, Pretoria, 8 Augustus 1987. Volkskastrust Bpk., Posbus 383, Pretoria.
- 12575/87—**Oosthuizen**, Johan Frederick, 19 Desember 1944, 4412195021004, Vistawoonstelle 21, Hendrik Verwoerdrylaan, Swartkop, 4 Augustus 1987. Volkskastrust Bpk., Posbus 383, Pretoria.
- 12674/87—**Jacobs**, Pieter Daniel, 20/3/11, 1103205017008, 18de Laan 887, Wonderboom-Suid, 25/8/87; Maria Elizabeth Jacobs, 8/3/15, 1503080014006. Volkskastrust Bpk.
- 8150/87—**Jubber**, Andries Petrus, 10 Junie 1923, 2306105012081, Huis 2, Rietvleikompleks, Pretoria, 10 Junie 1987; Anna Maria Magdalena Jubber, gebore Calitz, 20 Desember 1926, 2612200013001. Volkskastrust Bpk., Posbus 383, Pretoria.
- 10350/87—**Schoerie**, Agatha Johanna, 10 Mei 1916, 1605100003008, Eden-afreeoord, Karinpark, Pretoria, 14 Mei 1987. Volkskastrust Bpk., Posbus 383, Pretoria.
- 7551/87—**Smal**, Donald Steward, 28 Desember 1933, 3312285027005, 21ste Laan 569, Rietfontein, Pretoria, 12 April 1987; Susarah Elizabeth Smal, 27 September 1932, 3209270067006. Volkskastrust Bpk., Posbus 383, Pretoria.
- 10867/87—**Smit**, Daniel Martinus Nell, 28/5/08, 0805285002004, Willies Hillstraat 732, Pretoria-Tuine, 18/7/87; Elsje Petronella Smit, 3/5/15, 1505030001009. Volkskastrust Bpk., Posbus 383, Pretoria.
- 12729/87—**Cockburn**, Claude Archibald, 28/9/19, 1909285024007, Plot 96, Grootvlei, distrik Pretoria, 20 Augustus 1987; Miriam Deborah Cockburn, 8/12/24, 2412080054005. Volkskastrust Bpk., Posbus 383, Pretoria.
- 11600/87—**Van Jaarsveldt**, Phillipus Jacobus, 7/11/29, 2911075039004, Bulawayostraat 75, Ladanna, Pietersburg, 31/7/87; Catharina Petronella van Jaarsveldt, 10/5/33, 3305100001007. Volkskastrust Bpk., Posbus 383, Pretoria.
- 6414/87—**Belmore**, Susarie Elizabeth, 15 Mei 1923, 2305150062009, Boekenhoutlaan 52, Uitbreiding 3, Standerton, 7 April 1987. Van Heerden, Schoeman, De Ville & Boer, Posbus 39, Standerton.
- 12224/87—**Brandt**, Anna-Maria, 18 Oktober 1910, 1010180034009, Roscherstraat 16, Ventersdorp, 24 Augustus 1987. Maré, Van der Hoven & Gribnitz, Posbus 7481, Pretoria.
- 4802/87—**De Klerk**, Antonie, 20 Maart 1919, 1903205040003, H F Verwoerdstraat 21, Heidelberg, 20 Maart 1987; Elisabeth de Klerk, 12 Junie 1920, 2006120051003. De Klerk, Vermaak & Vennote, Posbus 875, Vanderbijlpark.
- 6277/87—**Koekemoer**, Sophia Elizabeth Fredrieka, 29 Maart 1934, 3403290013005, Orientstraat 386, Arcadia, Pretoria, 28 November 1986; Godliep Jacobus Roedolph Koekemoer. W. F. Bouwer, Posbus 8155, Pretoria.
- 12699/87—**Page**, Anna Elizabeth Fredrika, 22 Maart 1934, 4303220017001, Boekenhoutskloofstraat 1125, Booyens, Pretoria, 23 Augustus 1987. Frederik Geyer Page, 26 Mei 1931, 3105265011001. H. Dockendorff, Posbus 48736, Hercules.
- Terasa**, Bruno Heinz Gottfried, 4 February 1913, 1302045038105, Eaton Hall, 266 Visagie Street, Pretoria, 15 September 1987. Adams & Adams, P.O. Box 1014, Pretoria.
- 12593/87—**Redmond**, Samuel Louis, 1 October 1910, 1010015037003, 16 Coaton Avenue, Selcourt, Springs, 29 August 1987. Bennett, McNaughton & Jansen, P.O. Box 592, Springs.
- 9009/87—**Holmes**, Harold John Kenneth, 27 Desember 1961, 6112275051008, Retrieverstraat 497, Garsfontein, Pretoria, 20 Junie 1987. F. J. van Tonder, Posbus 30225, Les Marais.
- 12727/87—**Bellingham**, Nancy Margaret, 8 October 1921, 2110080077006, New Union Hotel, 573 Church Street, Arcadia, Pretoria, 15 September 1987. Pim Goldby, P.O. Box 519, Pretoria.

- 12882/87—**Erasmus**, Christina Elizabeth, 23/5/32, 3205230018006, Plot 614, Suurbekom, 17 Julie 1987. Eerste Persoonlike Batebestuur, Posbus 1538, Klerksdorp.
- 9362/87—**Shaw**, Agnes Grace, 27 December 1912, 1212270014004, 12 Rembrandt Road, Elmapark, Edenvale, 19 June 1987. Alex. Baillie, Koseff & Wheeler, P.O. Box 490, Benoni.
- 8548/87—**Du Plessis**, Gert Johannes, 30 Desember 1908, 0812305006007, Rooipoort, Ventersdorp, 26 Junie 1987. Nel Williams & Muller, Posbus 235, Ventersdorp.
- 5987/87—**Olwagen**, Elsie Johanna Catharina, 24 April 1908, Van Rensburg Monument-tehuis, Delanystraat 69, Danville, Pretoria, 16 Januarie 1987. Dyason Odendaal & Van Eeden, Posbus 793, Pretoria.
- 10925/87—**Datnow**, Mavis, 10 January 1922, 2201100015009, 306 Houghton Heights, 56 Second Avenue, Houghton, Johannesburg, 22 May 1987. Edward Nathan & Friedland Inc., P.O. Box 3370, Johannesburg.
- 4349/87—**Van Meyeren**, Johanna Anna, 21 July 1903, 0307210009006, Liesbeth de Vos Home, 32 Threadneedle Street, Brixton, Johannesburg, 14 March 1987. D. A. Carroll, P.O. Box 9191, Johannesburg.
- 9699/87—**Duearte**, Eva Phyllis, -/1933, 6 Asum Street, Riverlea, Johannesburg, 28 March 1987. Rom & Rom, Eighth Floor, Loveday House, 15 Loveday Street, Johannesburg.
- 10089/87—**Kater**, Arthur, 14 October 1914, 1410145035010, 27 Hamilton Street, Coronationville, Johannesburg, 7 July 1987. Edward Nathan & Friedland Inc., P.O. Box 3370, Johannesburg.
- 9554/87—**Broncho**, Norman Charles Joseph, 25 October 1931, 3210255022008, 83 Great Britain Street, Turffontein, Johannesburg, 28 June 1987. Patricia Jeannine Ulgheri, P.O. Box 39207, Booysens, Johannesburg.
- 11574/87—**Brand**, Ernest William, 12 December 1911, 1112125037004, 134 De Villiers Street, Kenilworth, Johannesburg, 2 August 1987. First Personal Asset Management Co., P.O. Box 2036, Johannesburg.
- 11994/87—**Baker**, Florence Victoria, 9 March 1907, 0703090002006, 20 Elliot Street, Rynfield, Benoni, 17 July 1987. First Personal Asset Management Co., P.O. Box 2036, Johannesburg.
- 11992/87—**Agriao**, Jose Fernandes, 19 March 1910, 1003195009108, 5 Christies Court, Burger Street, Krugersdorp, 24 July 1987; Constanca Agriao. First Personal Asset Management Co., P.O. Box 2036, Johannesburg.
- 8382/87—**Lutrin**, Rose, 14 May 1900, 0005140017004, 4 Charrow, corner of Harrow Road and Charlton Terrace, Doornfontein, 5 June 1987. L. D. Katz, P.O. Box 8633, Johannesburg.
- 12046/87—**Suliman (Surtee)**, Issak, 4/8/32, 3208045056054, 445 Hydrangea Avenue, Lenasia Extension 3, 22/8/87; Hawaivibi Suliman Surtee, 4/1/37, 3701040070054. Ayoob Kaka, P.O. Box 62083, Marshalltown.
- 12637/87—**Haxen**, Inge Vibeke, 22/4/22, 5 Bronte Road, Emerald Hill, Harare, Zimbabwe, 29/7/87. Laing Associates, P.O. Box 31546, Braamfontein.
- 8280/87—**Oliver**, Grace, 15 September 1910, 20 Nordic Court, Waverley, 17 June 1987. John Edward Broido, 1711 Sanlamsentrum, 210 Jeppe Street, Johannesburg.
- 14136/86—**Lenhoff**, Ella Rae, 15 February 1923, 2302150013009, 60 Third Avenue, Edenvale, 17 July 1986. Alec Massel Real Estate (Pty) Ltd, P.O. Box 5014, Boksburg North.
- 10235/87—**Brown**, Vincent Charles, 18 April 1945, 4504185058002, 7 Raasblaar Avenue, Glen Marais Extension 1, Kempton Park, 2 July 1987; Lutetia Brown, formerly Venter, born Welgemoed, 26 November 1949, 4911260057009. Roy Cohen, P.O. Box 9615, Johannesburg.
- 11288/87—**Osbourne**, Millicent Marion, 23 June 1906, Passport No. C735052C, 203 Trafalgar Square, Patrick Duncan Avenue, Florida Park, 14 August 1987. Richard F. Reed, P.O. Box 146, Florida Hills.
- 8038/87—**Blumberg**, Philip Charles, 26 December 1914, 1412265032009, 11 Ecksteen Street, Observatory East, Johannesburg, 19 February 1987. Hufel Klawansky & Farber, P.O. Box 156, Germiston.
- 10082/87—**Kanjee**, Chhotalal, 7/12/27, 2712075058055, 14 Van Heerden Street, Stanwest, Standerton, 23/6/87; Vasanti Chhotalal Kanjee, 22/1/29, 2901220037052. R. N. Bhoolia, P.O. Box 42259, Fordsburg.
- 11311/87—**Wolpe**, Dora, 4 June 1900, 0006040013002, Sandringham Gardens, George Avenue, Sandringham, Johannesburg, 25 July 1987. Gordon Michalson Silver & Frack, P.O. Box 719, Johannesburg.
- 12405/87—**Rose**, Samuel, 7 July 1902, 0207075013004, Soper Road, Berea, Johannesburg, 29 August 1987. Edward Nathan & Friedland Inc., P.O. Box 3370, Johannesburg.
- 5357/87—**Bhyat**, Moosa Amod, 2/12/12, 1212025036054, 15 Jan de Lange Street, Stanwest, Standerton, 20/7/86; Amina Bhyat, 1911190044054. Dockrat, Jassat & Associates, Second Floor, Transvaal Chambers, Vereeniging.
- 1966/87—**Pretorius**, Jacob, 12 April 1911, 1104125010008, 75 Eugene Marais Street, Rensburg, Heidelberg, 20 January 1987. Routledge-MacCallums, P.O. Box 306, Johannesburg.
- 12375/87—**Katzenberg**, Joseph, 19 December 1911, 1112195027000, 78 Dunottar Street, Sydenham, Johannesburg, 26 August 1987. B. Guttenberg, P.O. Box 3537, Johannesburg.
- 12614/87—**Wade**, Myer, 5 October 1911, 1110055008003, 35 Nellie Road, Norwood, Johannesburg, 4 August 1987. Joffe Kobrin & Lacob, Second Floor, 7a Sturdee Avenue, Rosebank.
- 11391/87—**Pater**, Klaas, 5 December 1924, 2412055046101, 202 Le Vegan, corner of Francis and Dunvegan Avenues, Edenvale, 11 July 1987. Wertheim Becker, P.O. Box 2102, Johannesburg.
- 5592/87—**Harry**, Ho Shau Kaw (Susan), 26 September 1946, 4609260118041, 25 Eighth Avenue, Bezuidenhouts Valley, Johannesburg, 13 March 1987. Edgar Salmon & Salmon, P.O. Box 4199, Johannesburg.
- 11557/87—**Booth**, Phyllis Roselia, 24 February 1936, 3602240073007, 48 Pope Street, Bellevue, Johannesburg, 6 July 1987. Van Hulsteyns, P.O. Box 46, Johannesburg.
- 12077/87—**Grieves**, John Thornton, 4/6/32, 3206045100104, 87 Yellowwood Street, Mayberry Park, Alberton, 23/8/87. Langstaffe Bird & Co., P.O. Box 4686, Johannesburg.
- 12363/87—**Easton**, Ian Geoffrey, 29/7/53, 5307295038008, 50 17th Street, Parkhurst, Johannesburg, 28/5/87. E. F. K. Tucker Inc., P.O. Box 100, Johannesburg.
- 11929/87—**Watts**, Donald Alfred, 7/1/09, 0901075017003, 36 Haldane Crescent, Wendywood, Sandton, 19/8/87. E. F. K. Tucker Inc., P.O. Box 100, Johannesburg.
- 4863/87—**Lubner**, Bella, 7 August 1902, 0208070014005, 88 Dingleton Road, Greenwich, Connecticut 06830, USA, 16 March 1987. Fisher Hoffman Stride, P.O. Box 1370, Johannesburg.
- 10842/87—**Melssner**, Hans Frederick, 3 March 1916, 1603035036003, 13 Ridge Road, Mountain View, Johannesburg, 1 August 1987. Ian McLaren, Seventh Floor, Delfers Square, Kerk Street, Johannesburg.
- 10572/87—**Benjamin (Benjamin)**, Flora Aharon, 12/11/12, 205 Matroosberg, Ockerse Street, Hillbrow, Johannesburg, 21/5/87. Slood Broido Hesselson & Liknaitzky, P.O. Box 1793, Johannesburg.
- 13703/86—**Kgasl**, Mamoshov Susan, 24/6/1896, 518672849, 2168 Orlando East, Soweto, 5/9/86. M. H. Cirotta, P.O. Box 261804, Excom.
- 9644/87—**Mamoojee**, Ebrahim Ismail. Dangors, P.O. Box 127, Lenasia.
- 12598/87—**Steele**, Zelma Millicent, 14 July 1925, 2507140033004, 25 Kent Road, Dunkeld, Johannesburg, 16 August 1987. Fisher Hoffman Stride, P.O. Box 1370, Johannesburg.
- 6956/87—**Sacks**, Rica, 18 September 1918, 331810943, 401 Northcrest, Abel Road, Berea, Johannesburg, 14 April 1987. Joel Melamed & Hurwitz, P.O. Box 9000, Johannesburg.

- 6568/87—**De Sousa**, Fernando Nogueira, 21/2/31, 3102215083107, 37 Cornelia Street, Troyeville, 3/5/87; Maria Fernanda Costa Mendes de Sousa, 15/4/37, 3704150099103. Joel Melamed & Hurwitz, P.O. Box 9000, Johannesburg.
- 11776/87—**Morris**, Rose, 8 December 1903, 0312080015000, 44 Velma Court, corner of Claim and Goldreich Streets, Hillbrow, Johannesburg, 9 August 1987. D. O. Thomas, P.O. Box 97044, Petervale.
- 9746/86—**Mokoena**, Jack, 1031515, 378 Phooko Section, Katlehong, Alberton, 17 March 1985. Moshidi Kunene & Makume, P.O. Box 133, Germiston.
- 9739/87—**Mosebi**, Samuel Tselengwe. Cohen, Berell & Levitham, P.O. Box 41322, Craighall.
- 12616/87—**West**, Ronald Francis, 16 May 1925, 2505165004009, 5 Cologne Road, Gerdview, Germiston, 2 August 1987. First Personal Asset Management Company, P.O. Box 2036, Johannesburg.
- 11808/87—**Tomazos**, George Socrates, 7 December 1907, 0712075034108, Ellis Park Hotel, Derby Road, Ellis Park, Johannesburg, 11 July 1987. First Personal Asset Management Company, P.O. Box 2036, Johannesburg.
- 12329/87—**Reid**, John James, 8 January 1956, 5601085022002, 15 Cloudsbank, River Road, Malanshof, Randburg, 18 July 1987. First Personal Asset Management Company, P.O. Box 2036, Johannesburg.
- 12456/87—**May**, Isobel Russell, 3 July 1913, 1307030019002, 203 Sunset Place, 1 Van der Merwe Street, Hillbrow, Johannesburg, 13 August 1987. First Personal Asset Management Company, P.O. Box 2036, Johannesburg.
- 11573/87—**Bolton**, Leslie Reginald, 29 May 1923, 2305295052105, Algernonweg 123, Norwood, 24 Julie 1987. First Personal Asset Management, P.O. Box 2036, Johannesburg.
- 12114/87—**Catherine**, Edward Paul, 21 April 1913, 1304215013009, 5 Colins Road, Melrose North, Johannesburg, 6 July 1987. First Personal Asset Management Company, P.O. Box 2036, Johannesburg.
- 11716/87—**Bromet**, Manus David, 28 August 1901, 0108285006004, 4 Impala Place, Hill Street, Randburg, 19 June 1987. First Personal Asset Management Company, P.O. Box 2036, Johannesburg.
- 12002/87—**Engelsman**, Margaret Jean, 4 April 1941, 4104040065001, 48 Kwartz Street, Farrarmere, Benoni, 1 August 1987. First Personal Asset Management Company, P.O. Box 2036, Johannesburg.
- 12561/87—**McLean Anderson**, Trevor James, 23/11/04, 0411235015004, 20 Elder Street, Fairmount, Johannesburg, 9/7/87. Standardtrust Ltd, P.O. Box 61452, Marshalltown.
- 12586/87—**Risi**, Cuigi Oresta Giovanni, 19/4/20, 2004195008008, 11 Northumberland Road, Kensington South, Johannesburg, 6/8/87. Standardtrust Ltd, P.O. Box 61452, Marshalltown.
- 10838/87—**Maciell**, Manuel de Sousa, 2/1/32, 3201025033102, 79 Charles Swart Avenue, Peacehaven, Vereeniging, 11/6/87; Maria Cidalia de Freitas. Standardtrust Ltd, P.O. Box 61452, Marshalltown.
- 11889/87—**Eliason**, Meyer, 31/5/14, 1405315024000, 39 Bushell Crescent, Selection Park, Springs, 31/7/87; Florence June Eliason. Standardtrust Ltd, P.O. Box 61452, Marshalltown.
- 9607/87—**Chambers**, Margaret Jane, 1916-01-26, 1601260018100, 1105 Philberta Court, Banket and Van der Merwe Streets, Hillbrow, 22/6/87. Standardtrust Ltd, P.O. Box 61452, Marshalltown.
- 11800/87—**Solomon**, Rose, 11 October 1906, 0610110045000, 305 Pioneer Place, 12 Soper Road, Berea, 24 July 1987. Raphaely-Weiner, P.O. Box 2590, Johannesburg.
- 2904/87—**Eksteen**, Joseph Martin, 7 November 1949, 4911075162002, divorced, 57 Buffalo Street, Leondale, Germiston, 15 February 1987. I. Kramer & Wesemann, P.O. Box 41, Benoni.
- 11256/87—**Ahmed**, Essop Docrat, 18 June 1987, 2001275049050, 8006 Hercules Street, Extension 9, Lenasia, 27 January 1987. Mayet Karolia Surtees and Ismail, P.O. Box 1759, Johannesburg.
- 11572/87—**Bezuidenhout**, Jacobus Petrus, 26/5/53, 5305265018000, 121 Viljoenlaan, Rothdene, 28/7/87; Francina Johanna Bezuidenhout, 5/9/59, 5909050006003. Bankorptrust Bpk., Posbus 2144, Potchefstroom.
- 9795/87—**Hattingh**, Judith Christina, 17/8/35, 3508170041007, Kritzingerstraat 12, Vanderbijlpark, 21/6/87; Adriaan Johannes Hattingh, 9/9/27, 2709075002000. Bankorptrust Bpk., Posbus 2144, Potchefstroom.
- 12475/87—**Redelinghuys**, Johanna Elizabeth, 15/3/16, 1603150041002, Klipdrift, Posbus 97, distrik Potchefstroom, 10/8/87. Bankorptrust Bpk., Posbus 2144, Potchefstroom.
- 1874/87—**Van Jaarsveldt**, David Johannes, 1 September 1923, 2309015005005, Sanlamparkwoonstelle 803, Bloemfontein, 5 Augustus 1987; Elizabeth Catharina van Jaarsveldt, 9 Julie 1925, 2507090014004. Boland Bank Bpk., Posbus 950, Pretoria.
- 12386/87—**Marais**, Susara Catharina, 26 September 1930, 3009260019003, Fraserlaan 36, Comet, Boksburg, 5 Julie 1987; Jochemus Johannes Jacobus Marais, 21 Junie 1926, 2606215034002. Eerste Persoonlike Batebestuur, Posbus 2036, Johannesburg.
- 11911/87—**Otto**, Frederick Jacobus, 29 December 1921, 2112295048004, St. Andrewswaai 11, Bordeaux, Randburg, 12 Augustus 1987; Elizabeth Johanna Christina Otto. Eerste Persoonlike Batebestuurder, Posbus 2036, Johannesburg.
- 10910/87—**Buckley**, Graham Douglas, 18 Junie 1948, 4806185001001, Galenalaan 142, Kloof-en-Dal, Roodepoort, 20 Julie 1987. Eerste Persoonlike Batebestuurder, Posbus 2036, Johannesburg.
- 12776/87—**Roux**, David Jordaan, 25 November 1915, 1511255029006, Parsonstraat 9, Vanderbijlpark, 25 Augustus 1987; Paulina Wilhelmina Roux, 21 Julie 1927, 2707210081004. Stabilitas Eksekuteurskamer (Edms.) Bpk., Posbus 11509, Johannesburg.
- 12041/87—**Rademeyer**, Magdalena Adriana, 25/12/47, 4712250073000, Allen Wellsweg 14, Discovery, Roodepoort, 1 Augustus 1987; Abraham Rademeyer, 17/8/45, 4508175098001. Stabilitas Eksekuteurskamer (Edms.) Bpk., Posbus 11509, Johannesburg.
- 12592/87—**Robbertse**, Nicolaas Johannes, 5 Augustus 1915, 1508055025002, 10a Creanstraat, Westonaria, 5 Augustus 1987; Olive Mary Robbertse, 15/9/15, 1509150037009. Standardtrust Ltd, P.O. Box 1992, Klerksdorp.
- 12554/87—**Meiring**, Gebriel Antonie, 4/10/16, 1610045036006, Daisystraat 5, Arconpark, Vereeniging, 14/8/87; Anna Johanna Meiring, gebore Fourie, 4/8/19, 1908040041009. Bankorptrust Bpk., Posbus 2144, Potchefstroom.
- 12576/87—**Opperman**, gebore Steyn, voorheen Van der Westhuizen. Heilie Jeanette, 22/8/31, 3108220051005, Plot 264, Hillside, Kocksvlei, 13/8/87; Phillipus Albertus Opperman, 17/4/31, 3104175038006. Bankorptrust Bpk., Posbus 2144, Potchefstroom.
- 9834/87—**Van der Westhuizen**, Willem Adriaan, 18/7/36, 3607185035002, Plot 11, Stilfontein Plaas, Stilfontein, 18/6/87; Frances Juanite van der Westhuizen, gebore Bernardi, 30/9/39, 3909300052007. Bankorptrust Bpk., Posbus 2144, Potchefstroom.
- 11387/87—**Van Onselen**, Jurgens Johannes, 31/3/19, 1903315005003, Olienhoutstraat 14, Elspark, 13/8/87; Anna van Onselen, née Van Rooyen, 3002070008001. Bankorptrust, Posbus 1081, Kempton Park.
- 11118/87—**Nel**, Michiel Daniel, 28/6/57, 5706285128002, Danielweg 10, Lilianton, Boksburg, 29/6/87; Marina Catharina Green, 6310170079005. Bankorptrust, Posbus 1081, Kempton Park.
- 11692/87—**Nel**, Willem Adriaan, 1928-10-22, 28102235028008, Hendriklaan 14, Glen Marais, Kempton Park, 31/7/87; Getruida le Sueur Nel, 2/4/32, 3204020031006. Van Rensburg, Schoon & Cronje, Posbus 755, Kempton Park.
- 8262/87—**Prinsloo**, Marthinus Jacobus Abraham, 4 April 1919, 1904045034008, Derde Laan 17a, Mayfair, Johannesburg, 28 Mei 1987; Magdalena Aletta Prinsloo, gebore De Jager, 5 Oktober 1926, 2610050028004. S. A. Meyer & Kie., Posbus 35760, Northcliff.
- 9793/86—**Van den Bergh**, Anna Magdalena, 1507030055001, 3 Waxbill Street, McKenzie Park, Benoni, 23/6/87. F. Herbert, P.O. Box 431, White River.
- 11371/87—**Meyer**, Wilhelmus Petrus Antonius, 27 July 1916, 1607275037100, 100 Ferreira Street, Turffontein, Johannesburg, 27 July 1987. William M. Salakoff, P.O. Box 3886, Johannesburg.

- 12127/87—**Holmes, Leonard Chambers** Kemsley, 30/1/19, 19013045048009, 18 Third Avenue, Edenvale, 30/1/87; Peacy Chalmers Holmes. Standardtrust Ltd, P.O. Box 61452, Marshalltown.
- 12474/87—**Rusch, Otto Konrad**, 12 April 1914, 1404125020100, 5 49 Richards Drive, Halfway House, 22 August 1987. Bankorptrust Bpk., Posbus 602, Johannesburg.
- 8730/87—**Bezuidenhout, Pieter Martin**, 19 Junie 1947, 4706195048002, Ochsestraat 212, Danville, 22 Mei 1987; Hendrina Maria Bezuidenhout, 18 Oktober 1955, 5510180159009. Bankorptrust Bpk., Posbus 4680, Pretoria.
- 11567/87—**Botha, Benjamin Johannes**, 17 Oktober 1922, 2210175032005, 30ste Laan 686, Villieria, Pretoria, 31 Julie 1987; Engela Susanna Botha, 10 Februarie 1923, 2302100021003. Bankorptrust Bpk., Posbus 4680, Pretoria.
- Cairncross, Charles Christoffel**, 30 Julie 1930, 3007305032007, 53 Drogenkloof, distrik Warmbad, 29 Augustus 1987; Johanna Magrietha Susanna Cairncross, gebore Joubert, 13 Augustus 1932, 3208130018001. Bankorptrust Bpk., Posbus 4680, Pretoria.
- 13131/87—**Nolte, Jacobus Everhardus**, 4 Mei 1946, 4605045001007, Silkaatsnek 27, Brits, 16 September 1987. C. A. Nolte, Posbus 2033, Randburg.
- 7700/87—**Kotze, Johannes Jacobus**, 4 November 1927, 2711045013000, 23ste Laan 887, Pretoria, 8 Junie 1987. Dyason Odendaal & Van Eeden, Posbus 793, Pretoria.
- 9436/87—**Jansen van Rensburg, Marthinus Phillipus**, 0507145004002, 11/7/87. Mev. S. E. Jansen van Rensburg, Bettie Prinsloostraat 16, Annlin.
- 11207/87—**Nieman, Johanna Jacomina**, 11 May 1920, 2005110061006, 55 Nurneylaan, Crosby, 20 Julie 1987; Gideon Johannes Nieman. Eerste Persoonlike Batebestuur, Posbus 2036, Johannesburg.
- 11777/87—**Naude, Wilhelmina Johanna**, 29 June 1910, 1006290014006, Sentraalweg 62, Linden-uitbreiding, Randburg, 13 Augustus 1987. Syfrets Trust Bpk., Posbus 61058, Marshalltown.
- 11843/87—**Marais, Endrietta Wilhelmina**, 9 November 1943, 4311090001006, Wilgerlaan 6, Generaal Albertspark, Alberton, 6 Augustus 1987. Syfrets Trust Bpk., Posbus 61058, Marshalltown.
- 11737/87—**Dorfling, Joachim Marthinus**, 14 March 1947, 4703145118001, 59 Olive Road, Primrose, East Germiston, 23 July 1987. Syfrets Trust Ltd, P.O. Box 60158, Marshalltown.
- 8945/85—**Rossouw, Maria Magdalena**, 15 Mei 1907, 0705150013005, Terblanchelaan 48, Sundra, 16 Junie 1985; Gert Stephanus Rossouw, 5 Maart 1912, 1203055011000. Santamtrust Bpk., Posbus 602, Johannesburg.
- 1596/87—**Opperman, Marthinus Jacobus**, 13 September 1940, 4009135059001, Elandiaawoonwapark, Jacobaweg 80, Alberton, 8 Desember 1986. J. T. Louw, Wolterlaan 274, Northcliff View.
- 12288/87—**Bester, Lewis**, 13 Oktober 1934, 3410135017007, Tulbachweg 35, Culemborgpark, Randfontein, 7 Augustus 1987; Christina Wilhelmina Gertruida Bester, 8 April 1937, 3704080050002. H. M. Nel, Posbus 918, Roodepoort.
- 12355/87—**Botha, Cornelia Helena Evelyn**, 28 Mei 1931, 3105280005004, Pieterstraat 11, Southcrest, Alberton, 1 Augustus 1987. Eerste Persoonlike Batebestuur, Posbus 2036, Johannesburg.
- 12378/87—**Kilian, Christoffel Jacobus Lodewicus**, 16 Mei 1912, 1205065014007, Marmanet 11, Terenure-uitbreiding 20, Kempton Park, 29 Julie 1987; Cornelia Carolina Catharina Kilian. First Personal Asset Management Company, P.O. Box 2036, Johannesburg.
- 9251/87—**Strydom, Hester Sophia**, 29 Maart 1906, 0603290023002, Yorkstraat 9, Kensington B, Randburg, 2 Julie 1987. C. A. Nolte & Van Rooyen, Posbus 2033, Randburg.
- 10591/87—**Jordaan, Hendrik Christoffel**, 2/10/43, 4310025081000, Piekaarlaan 10, Nederlandpark, Ermelo, 27/7/87; Aletta Elizabeth Dorathea Jordaan, 9/3/50, 5003090090001. Boland Bank Bpk., Posbus 363, Ermelo.
- 11878/87—**Botes, Marthinus Nicolaas**, 22/5/09, 0905225002005, Mendelsohnstraat 23, Vanderbijlpark, 21/7/87; Martha Sophia Botes. Standardtrust Bpk., Posbus 61452, Marshalltown.
- 11955/87—**Roets, Petrus Nicolaas Johannes**, 21/12/06, 0612215013006, Betsy Verwoerd-tuis vir Bejaardes, Conradrylaan, Blairgowrie, 6/8/87. Standardtrust Bpk., Posbus 61452, Marshalltown.
- 10702/87—**Botha, Isak Johannes Jacobus**, 23/5/15, 1505235009005, Mainstraat 76, Farrarmere, Benoni, 19/6/87; Heila Levina Helena Catharina Botha, 7 Oktober 1918, 1810070008009. Standardtrust Bpk., Posbus 61452, Marshalltown.
- 9310/87—**Hoek, Johanna Christina**, 28 Desember 1924, 2412280057105, 19de Straat 4, Malvern, Johannesburg, 6 Julie 1987; Johannes Zacharias Hoek, 2 April 1924, 2404025030109. Bankorptrust Bpk., Posbus 602, Johannesburg.
- 2510/86—**Jansen van Vuuren, Daniël Rudolph Petrus**, 28 Mei 1922, 2205285016005, Plot 81, Doornbult, Pietersburg, 3 Februarie 1986. Bankorptrust Bpk., Posbus 602, Johannesburg.
- 12453/87—**Lubbe, Hendrik Johannes**, 4/1/40, 4001045020009, Bultfontein 28, Nigel, 4/7/87; Magrietha Martha Lubbe, gebore Venter, 6/10/44, 4410060064000. Bankorptrust Bpk., Posbus 1081, Kempton Park.
- 12530/87—**Higgo, William George**, 12/1/27, 2701125014002, Gerrit Maritzstraat 37, Secunda, 19/6/87; Ramona Higgo, 3202270006009. Bankorptrust Bpk., Posbus 1081, Kempton Park.
- 11485/87—**Wagner, Susanna Cornelia Magrieta**, 26 Oktober 1950, 5010260034008, Theatre View 702, Gerhard Moerdykstraat, Pretoria, 12 Augustus 1987. Couzyn, Hertzog & Horak Ing., Sesde Verdieping, Trustbankgebou, Sentraalstraat, Pretoria.
- 9858/87—**Froggatt, Leslie Jack Froggatt**, 8 Februarie 1921, 2102085069104, 46 Frederick Copper Drive, Kenmare, Krugersdorp, 28 Junie 1987. J. B. Hugo & Cronje, Posbus 115, Krugersdorp.
- 13025/87—**Brunette, Johanna Ulrich**, 30/9/05, 0509300018009, Flowerstraat 153, Capital Park, Pretoria, 2/9/87. Standardtrust Bpk., Posbus 1330, Pretoria.
- 12005/87—**Gray, James**, 4/4/23, 23040450250006, Pretoria, 19 August 1987. Standardtrust Ltd, P.O. Box 1330, Pretoria.
- 9846/87—**Coetzee, Maria Magdalena**, 26 Junie 1943, 4306260054009, Louw Bekkerstraat 1, Breyten, 2 Julie 1987; Gideon Johannes Coetzee, 9 September 1944, 4409095080007. Bankorptrust Bpk., Posbus 4680, Pretoria.
- Coetzee, Maria Elizabeth**, 27 Junie 1920, 2006270018000, Ville Savannah 26, Sprokielaan, Faerie Glen, 27 Augustus 1987. Bankorptrust Bpk., Posbus 4680, Pretoria.
- 12264/87—**Du Plessis, Frederik Johannes**, 3 Augustus 1958, 5808035001008, Tumbortstraat 62, Witbank, 2 Augustus 1987. Bankorptrust Bpk., Posbus 4680, Pretoria.
- 11257/87—**Duvenage, Petrus Stephanus Zacharias**, 19 Maart 1943, 4303195021005, Rooihuitlaan 14, Camden, distrik Ermelo, 29 Julie 1987; Maria Jacoba Duvenage. Bankorptrust Bpk., Posbus 4680, Pretoria.
- 12641/87—**Grobler, Pieter Hendrik**, 10/1/25, 2501105046002, Wonderboomstraat 605, Pretoria-Noord, 30/8/87; Johanna Magdalena Grobler, 23/4/26, 2604230052000. Bankorptrust Bpk., Posbus 4680, Pretoria.
- 9408/87—**Holtzhausen, Nicholas Thomas**, 7 Januarie 1938, 3801075113009, Joubertstraat 54a, Middelburg, 11 Junie 1987; Magrietha Fredrika Holtzhausen, 28 Februarie 1941, 4102280121005. Bankorptrust Bpk., Posbus 4680, Pretoria.
- 7496/87—**Kleiser, Werner Helmut**, 12/5/39, 3905125066107, Damazawoonstelle 504, Arcadia, 1 Junie 1987; Giovanna Kleiser. Bankorptrust Bpk., Posbus 4680, Pretoria.
- 10855/87—**Russell, Charles Joseph**, 13/5/58, 5805135075007, Nightingalerylaan 21, Elspark, Germiston, 5 Julie 1987. Bankorptrust Bpk., Posbus 2413, Bloemfontein.
- 9963/87—**Viljoen, Hendrik Pieter Jacobus**, 16 Junie 1932, 3206165051004, Huntleystraat 9, Hursthill, Johannesburg, 21 Julie 1987; Johanna Maria Magrietha Viljoen. Bankorptrust Bpk., Posbus 4680, Pretoria.

- 11925/87—**Van Sittert**, Stephanus Cornelius, 27 Oktober 1913, 1310275024000, Landdros Maréstraat 7, Pietersburg, 18 Julie 1987. Bankorptrust Bpk., Posbus 4680, Pretoria.
- 11073/87—**Jansen van Vuuren**, Engela Susara, 31 Januarie 1939, 3901310012006, Hoewe 24, Mont Lorraine Landbouhoewes, Pretoria distrik, 18 Julie 1987; Jan Lodewyk Jansen van Vuuren, 11 Julie 1937, 3707115004001. Bankorptrust Bpk., Posbus 4680, Pretoria.
- 12218/87—**Jansen van Vuuren**, Hendrik Stephanus, 3/10/26, 2610025002009, Pietersburgstraat 10, Ladanna, Pietersburg, 3/8/87; Magdalena Maria Dorothea van Vuuren. Bankorptrust Bpk., Posbus 4680, Pretoria.
- 11651/87—**Van Zyl**, George Andries, 28 Februarie 1940, 4002285077006, Bostonstraat 4, Secunda, 7 Junie 1987; Nellie Antoinette van Zyl, 24 Maart 1947, 4703240056007. Bankorptrust Bpk., Posbus 4680, Pretoria.
- 5391/97—**Bonse**, Derek Paul, 22 Januarie 1963, 6310225008009, CMTC, Stilfontein, 12 Maart 1987. Chris Blom & De Jager, Posbus 1445, Rustenburg.
- 13111/87—**Lüdck**, Zirk Jacobus, 28 Julie 1920, 2007285042001, Vyfdelaan 38, Welverdiend, 6 September 1987. Laage Schoeman & Stadler, Posbus 854, Carletonville.
- 12096/87—**Barwise**, Catharina Elizabeth, 28/5/52, 5250280098005, 7 Hamlet Oord, Sunward Park, Boksburg, 9/8/87; Geoffrey Keith Barwise, 17/1/52, 5201175101004. Syfrets Trust Ltd, P.O. Box 29980, Sunnyside.
- 10936/87—**Grimbeek**, Judith Catharina Elizabeth, 15/4/15, 354853362W, Klipdrift, Potchefstroom, 29/7/87. Syfrets Trust Bpk., Posbus 29980, Sunnyside.
- 9413/87—**Luchies**, Gerrit, 5/2/39, 3902055072106, Stockenstroomstraat 36, Vanderbijlpark, 27/6/87; Jacoba Luchies, 9/12/35, 3512090071102. Syfrets Trust Bpk., Posbus 29980, Sunnyside.
- 11244/87—**Barrow**, Thomas Arthur, 5/2/13; 1302055034002, 10 Essenhout Street, Parkville, White River, 9 July 1987; Evelyn Margaret Barrow, 18/6/20, 2006180037009. R. Oertli, P.O. Box 767, Halfway House.
- 12119/87—**Esterhuizen**, Johanna Catharina, 2 Maart 1899, 9903020002008, Gedeelte 10 van die Plaas Goedeheop 358, 15 Julie 1987. Haasbroek & Boezaart, Vyfde Verdieping, NEG-gebou, Vermeulenstraat 362, Pretoria.
- 11218/87—**Janse van Rensburg**, Nicolaas Marthinus, 4 Desember 1937, 356286797W, Naomilaan 39, Annlin, Pretoria, 8 Augustus 1987; Johanna Marthina Christina Susanna Janse van Rensburg, gebore Benade, 17 Augustus 1940, 4008170079007. Bornman & Dreyer, Posbus 40702, Arcadia.
- 10999/87—**Solomon**, Anita, formerly Berzen, born Smith, 2 August 1929, 2908020049005, 43 Balrea Flats, Devenish Street, Sunnyside, 9 August 1987. First National Bank Ltd, P.O. Box 40076, Arcadia.
- 8511/87—**Watt**, William, 13/6/12, 1206135015008, Room V2, Kronendal, Pretorius Street, Pretoria, 18/6/87. First National Bank Ltd, P.O. Box 40076, Arcadia.
- 7007/87—**Luykx**, Susanne Anna Augusta, born Bernard, 27/8/43, 4308270148102, 103 Seventh Street, Cullinan, 26/5/87; Jean-Marie Fernand Dominique Luykx. First National Bank Ltd, P.O. Box 40076, Arcadia.
- 10691/87—**Rademeyer**, Lambertus von Willigh Bester, 7/10/28, 2810075026005, Camelialaan 80, Lynnwoodrif, 27/7/87. Eerste Nasionale Bank Bpk., Posbus 40076, Arcadia.
- 7639/87—**Richter**, Wynand Frederik, 12 Junie 1914, 1406125016004, Cantonmentsweg 109, Lyttelton, Verwoerdburg, 7 Junie 1987; Johanna Magdalena Richter, gebore Delpont. Eerste Nasionale Bank Bpk., Posbus 40076, Arcadia.
- 11841/87—**Leibowitz**, Joseph Romney, 1 Desember 1947, 4712015071000, Rooihartbeeslaan 99, Theresa Park-uitbreiding 2, Pretoria, 19 Augustus 1987. Eerste Nasionale Bank Bpk., Posbus 40076, Arcadia.
- 11067/87—**Schuurman**, Henri Johann. 13 February 1898, 9802135004000, 99 Wolmarans Street, Rustenburg, 19 July 1987. First National Bank Ltd, P.O. Box 40076, Arcadia.
- 9903/87—**Botha**, Gabriel Gerhardus, 3 November 1918, 1811035019008, Plot 7, Noordloch, 13 Julie 1987; Isabella Petronella Botha. Eerste Nasionale Bank Bpk., Posbus 40076, Arcadia.
- 12578/87—**Du Plessis**, Johannes Christian, 13 Augustus 1939, 3908135024009, Droogfontein, distrik Delmas, 27 Augustus 1987. Eerste Nasionale Bank Bpk., Posbus 40076, Arcadia.
- 9747/87—**Potgieter**, Johannes Jurgens, 26 Augustus 1910, 1008265007007, Amsterdam, 15 Julie 1987; Sara Susanna Potgieter. Eerste Nasionale Bank Bpk., Posbus 40076, Arcadia.
- 8751/87—**Joubert**, Zacharias Francois, 1 Februarie 1909, 0902015045005, Warmbad-Rusoord, Warmbad, 3 Julie 1987. Eerste Nasionale Bank Bpk., Posbus 40076, Arcadia.

KAAP • CAPE

- 6513/87—**Jason**, Amelia Louisa Isabel, 7 Desember 1915, 000014490634, weduwee, Andersonstraat 21, Goodwood, 15 Augustus 1987. Strauss & Haasbroek-Guthrie & Theron, Voortrekkerweg 45, Goodwood.
- 1472/87—**Young**, Sophia Fredrika, 6 Mei 1947, 4705060137080, Strandstraat 862, Narraville, 23 November 1986; Andrew Robert Young, 21 Desember 1946, 4612215035203. C. L. de Jager & Van Rooyen, Posbus 224, Walvisbaai.
- 6821/87—**Boonzaaier**, Johanna Ermina Jacoba, gebore Gerstner, 25/12/03, 0312250024006, Huis Vergenoegd, Hoofstraat, Paarl, 6/9/87. Boland Bank Bpk., Posbus 236, Paarl.
- 6109/87—**Eckford**, Charles Vyvyan Lavers, 15 November 1905, 0501155021105, 15 Prospect Avenue, Somerset West, 9 August 1987. Venter & McNaught Davis, United Building, 140 Main Street, Somerset West.
- 5583/87—**Forbes**, Sidney William Robert, 31 Oktober 1912, 1210315039002, Camel Rock Road, Scarborough, 17 Julie 1987; Gladys Christina Anna, 13 Mei 1921, 2105130038008. Van Niekerk Groenewoud & Van Zyl, 101 Fintrustgebou, Mazzurstraat, Bellville.
- 6861/87—**Benjamin**, Hendrick Fortuin, 12 February 1915, 1502125057012, 38 Bougaardt Street, Paarl, 12 August 1987; Grace Maud Benjamin, born Madden, 5 November 1916, 1611050050105. Faure & Faure, 227 Main Street, P.O. Box 20, Paarl.
- 2230/87—**Gildenhuys**, Hendrik Jacobus, 3 January 1921, 2101035077001, Kruismansrivierplaas, Piketberg, 11 March 1987; Bertha Wilhelmina Alletta Gildenhuys, 12 September 1923, 2309120103083. Pincus Matz—Marquard Hugo-Hamman, 135 Main Road, Claremont.
- Ehlers**, Jacobus Gideon Johannes, 1 Januarie 1902, 0201015007002, Loopstraat 92, Piketberg, 25 September 1987; Sarah Johanna Ehlers, gebore Coetzee, 21 Junie 1913, 1306210046009. Burger & Jonker, Posbus 6, Citrusdal.
- 6261—**Scholtz**, Frederika Jacoba, 20/8/32, 3208200004006, De Neyssenstraat 8, Strand, 6 Augustus 1987; Hendrik Petrus Jacobus Scholtz, 13/3/29, 2903185004002. Volkskastrust, Posbus 873, Bellville.
- 5856/87—**Du Plessis**, Edmund Bertram, 18/5/18, 1805185007003, Unionstraat 48, George, 1/8/87; Aletta Fredrieka du Plessis, 7/7/15, 1507070039006. Volkskastrust, Posbus 873, Bellville.
- 6680/87—**Young**, Isak Petrus, 12 April 1922, 2204125026001, Dwarsweg, distrik George, 3 September 1987. Raubenheimers, Posbus 21, George.
- 6938/87—**Stemmet**, Francois Philippus, 2/12/02, 0212025003006. Dirkie Uysstraat 13, Franschoek, 17/8/87; Susanna Johanna Stemmet, gebore Stone, 15/7/12, 1207150018000. Boland Bank Bpk., Posbus 236, Paarl.
- 7036/87—**Van der Merwe**, Elizabeth Rachel, gebore Cloete, 18/1/1902, 096712301W, Pieter Wiumstraat 61, Noorder-Paarl, 17/9/87. Boland Bank Bpk., Posbus 236, Paarl.
- 6504/87—**Barnard**, Hendrik Christoffel, 15 Oktober 1909, 0910155011000, Brandwachtstraat 53, Brandwacht, Stellenbosch, 26 Augustus 1987; Martha Johanna Jacomina Barnard, gebore Van Wyk, 17 Maart 1912, 1203170002009. Cluver & Markotter, Posbus 12, Stellenbosch.
- 4622/87—**Helyar**, Dennis William Hawker, 29 June 1926, 2607295018006, 61 Riverside Park, Somerset West, 22 April 1987. J. A. Redelinghuys, P.O. Box 52781, Saxonwold.

- 6774/87—**Jacobs**, Adam Johannes Jacobus, 14 Mei 1915, 1505145069016, Fabriekstraat 11, Ceres, 28 Julie 1987. Hauptfleisch & Muller, Posbus 6, Ceres.
- 4650/87—**Joubert**, Izak Jacob, 5/8/42, 4208055024009, Moutonstraat 4, Kuilsrivier, 26 Junie 1987. F. J. Joubert, Port Jacksonstraat 6, Kuilsrivier.
- 3707/87—**Swanepoel**, Hendrik Johannes, 6 Februarie 1956, 5602065021006, Barclayfarm, Brandwag, Worcester, 18 Mei 1987; Mariaan Johannie Swanepoel, gebore Briedenmann, 30 Julie 1964, 6407300070001, Conradie & Vennote, Posbus 112, Worcester.
- 6835/87—**Van Dyk**, Catharina Johanna Maria, gebore Van Dyk, 3/1/25, 2501030021005, Sea Viewrylaan 307, Franskraal, Gansbaai, 7 September 1987; Carel Christiaan van Dyk, 11/5/16, 1605115005006, D. P. van Dyk, High Trees 6, Durbanville.
- 6625/87—**Le Roux**, Charl Johannes, 6/12/20, 2012065012000, Derde Laan 52, Kleinmond, 23/8/87; Woutrina Catherina le Roux, gebore Du Plooy, 3/5/21, 2105030052000, Boland Bank Bpk., Posbus 34, Caledon.
- 6894/87—**Steyn**, Gideon Hendrik, 19/4/07, 0704195007007, Viewfieldweg 6, Somerset-Wes, 7 September 1987; Christina Susanna Gertruida Steyn, 21 September 1917, 1709210030008, Rowan & Pullen, Barclays Bankgebou, Hoofweg, Strand.
- 6655/87—**Smuts**, Engela Cornelia, gebore Bresler, 30 Desember 1898, 9812300004008, Soeterus-ouetehuis, Olivierstraat, Strand, 17 Augustus 1987. Boland Bank Bpk., Posbus 56, Strand.
- Fourie**, Pieter Stephanus, 23/9/25, 2509235020003, Sesde Laan 14, Mosselbaai, 13/9/87. Standardtrust Bpk., Posbus 765, George.
- 6518/87—**Leube**, Karl Heinrich Hermann, 20 May 1920, 2005205065102, 19 Tulbagh Street, Brooklyn, 25 August 1987. A. Wagner de Villiers, P.O. Box 1179, Cape Town.
- 6762/87—**Botha**, Johannes Christian Erns, 12/12/34, 3412125045009, 805 Mark Heights, Wallace Street, Goodwood, 17/8/87; Lynette Botha, 26/12/43, 4312260066001, R. I. K. Cameron, P.O. Box 146, Bellville.
- 6718/87—**MacPherson**, William Ewan, 20 June 1897, 9706205011102, Pallottie Nursing Home, George, 10 August 1987. McGregors, 11b Nedbank Centre, C. J. Langenhoven Road, George.
- 6231/87—**Striskey**, Francois George, 10 Julie 1946, Bo Parkstraat 5, Wellington, 19 April 1987; Kathleen Magdaleen Amelia Sally Striskey, 2/4/46, Jan S. de Villiers & Seun, Posbus 1474, Kaapstad.
- 6820/87—**Snyman**, Johannes Cornelius, 17/11/14, 1411175029006, Serena 8, Durbanweg, Bellville, 8/8/87; Jacomina Jacoba Snyman, 6/5/16, 1605060009003, Volkskastrust Bpk., Posbus 873, Bellville.
- 6719/87—**McQueen**, May, 12/12/04, 0412120030009, Anchusa House, Meadowridge, Cape Town, 7/8/87. Bowman Gilfillan Hayman Godfrey Inc., P.O. Box 2439, Johannesburg.
- 3592/87—**Idle**, Muriel Kathleen, 24 December 1920, 2012240029002, 7 Hilton Road, Mowbray, Cape Town, 15 May 1987. M. M. Shefer & Co., P.O. Box 12080, Centrahil.
- 6277/87—**Olckers**, Pieter Daniel, 18/7/13, 1307185004007, Melvilleweg 96, Plumstead, 9/7/87. Volkskastrust Bpk., Posbus 873, Bellville.
- 6649/87—**Casper**, Anthony, 24 Desember 1952, Geneva Close 6, Mitchells Plain, 9 Julie 1987; Jacqueline Beatrice Casper, 22 Augustus 1954. Johan van Wyk, Bellpark Plaza 7a, hoek van Durbanweg en De Langestraat, Bellville.
- 6816/87—**Ontong**, Joslyn, 17/1/47, 0967405010K, Sederlaan 23, Paarl, 22/6/87; Veronica Anne Ontong, gebore Williams, 22/12/49, 4912220107017, Boland Bank Bpk., Posbus 236, Paarl.
- 6248/87—**Van den Heever**, Gert Jacobus, 5 September 1918, 1809055020005, Serenitas 138, Strand, 17 Augustus 1987. Boland Bank Bpk., Posbus 56, Strand.
- 5812/87—**Cloete**, Simon Petrus, 6/2/50, 5002065145014, Hostelstraat, Steinkopf, 15/7/87; Hilda Regina Janetta Cloete, 28/3/45. D. J. Scholtz & De Wit, Posbus 35, Springbok.
- 6724/87—**Janse van Rensburg**, Adriaan Francois, 23 Augustus 1896, 9608235004000, Tehuis Jan Lange, Wardenstraat, Riversdal, 26 Julie 1987; Johanna Louisa Petronella Janse van Rensburg, 11 Junie 1901, 0106110018004, Hofmeyer & Seun, Posbus 16, Riversdal.
- A/1162/87—**Ajmoodien**, Ebrahiem, 7/4/30, 007736097M, 66, 13th Street, Kensington, 21/1/86. E. Moosa & Associates, First Floor, Bhofin Centre, George Street, Athlone.
- 6360/87—**Freitas**, Antonio Gouveia, 31 October 1912, 1210315049100, Kinlune and Rosedale Home for the Aged, Salisbury Road, Kenilworth, 15 August 1987; Maria Freitas, born De Nobrega, 12 June 1924, 2406120039109, Herbsteins, P.O. Box 1221, Cape Town.
- 6720/87—**Moir**, Albert Duncan, 8/11/20, 2011085050008, 54 Upper Kildare Crescent, Fish Hoek, 22 August 1987. Guthrie & Rushton, 102 Fish Hoek Centre, Main Road.
- 6831/87—**Cameron**, Vera Grace, 20 February 1918, 1802200033007, 31 St Davids Road, Newlands, 8 September 1987. Haydn Elmes & Elmes, P.O. Box 15072, Vlaeberg.
- 5753/87—**Dreyer**, James Andrew John, 15 July 1936, 3607155102014, 14 Hodson Road, Retreat, 26 July 1987; Julia Henrietta Deyer, born Larry, 12 October 1936, 3610120102010, Penkin Zeller & Karro, P.O. Box 43, Cape Town.
- 6239/87—**Davidson**, John Milner, 4 March 1905, 0503045028001, 107 Sheldon Park, Howard Drive, Pinelands, 18 Augusts 1987. Bisset, Boehmke & McBlain, P.O. Box 76, Cape Town.
- 6638/87—**Golovin**, Semion, 14/1/03, 14 St Johns Road, Sea Point, 3 September 1987. Bass Gordon Willis, P.O. Box 838, Cape Town.
- 131/87—**Shiffman**, Sam, 4/5/23, 2305045088003, Highlands House, Upper Buitekant Street, 9/12/86. Bloomberg & Co., 56 Shortmarket Street, Cape Town.
- 1367/87—**Hartley**, Madenea (also known as Abader), 21 December 1932, 022252328M, 9 Duke Street, Walmer Estate, Woodstock, 8 May 1984. Van der Ross & Motala, 60 Sir Lowry Road, Cape Town.
- 6675/87—**Solomon**, Asia, 0228404161M, 92, 10th Avenue, Kensington, 17 April 1987. De Beer & Marquard, P.O. Box 19, Woodstock.
- 6612/87—**Siff**, Robert Philip, 1 July 1913, 1307015027004, 710 Clarensville, Beach Road, Sea Point, 3 September 1987. Syfret Godlonton-Fuller Moore Inc., P.O. Box 695, Cape Town.
- 6715/87—**Jones**, John Leonard, 20/11/20, 2011205108181, 6 Highgate, 111 Kommetjie Road, Fish Hoek, 21/8/87. Guthrie & Rushton, P.O. Box 22087, Fish Hoek.
- 6070/87—**Hicks**, Seymour John James, 27 March 1916, 1603275007003, 205 Knightsbridge, Beach Road, Sea Point, 29 July 1987; Elizabeth Catherine Hicks, 3 May 1921, 2105030005008, S. M. Kessler Lazarus & Borok, P.O. Box 83, Goodwood.
- 6801/87—**Milward**, Stanley John, 26 December 1921, 2112265061003, 31 Putter Street, Lakeside, 13 August 1987. Lansdown Ellis & Company, Fifth Floor, Premier Centre, 451 Main Road, Observatory.
- 6697/87—**Vergers**, Marinus Cornelius, 22/7/11, 1107225023003, 46 Berkley Square, Main Road, Rondebosch, 28/8/87. Asherson & Asherson, P.O. Box 2219, Cape Town.
- 6331/87—**Greyling**, Florence Joyce, 15/11/23, 2311150032000, 17 Oak Farm Crescent, Constantia, 4/7/86. Arthur E. Abrahams & Gross, 2 Long Street, Cape Town.
- 6803/87—**Potterton**, Annie Charlotte, 27/12/14, 1412270060102, 703 Senator Park, Keerom Street, Cape Town, 28 August 1987. Silberbauers, P.O. Box 921, Cape Town.
- 5802/87—**Snijder**, Hendrik Jan, 22/8/01, 0108225012005, 79 Berg Road, Fish Hoek, 17 July 1987. Thompson Smithers & Bradley Inc., 102 Medical Centre, Maynard Road, Wynberg.
- 6704/87—**Young**, Frances Ann, 17 February 1931, 3102170090089, 42 Royal Avenue, Hout Bay, 21 Augusts 1987. Pim Goldby, P.O. Box 578, Cape Town.
- 6115/87—**Powell**, Edna Maud Elizabeth, born Muller, 11/3/23, 2303110058019, 4 Mathei Street, Pinati Estate Lansdowne, 14 July 1987; William Lewis Powell, 24 April 1921. Zeldia Gordon & Associated, P.O. Box 24351, Lansdowne.

- 6627/87—**Stephens**, Georgina Ogilvie, (formerly Ames), born Strachan, 17 August 1890, 9008170003002, Quest, 294 Main Road, Kalk Bay, 5 September 1987. Syfrets Trust Ltd, 24 Wale Street, Cape Town.
- 6759/87—**Willis**, Barbara Denne, 30 March 1911, 1103300065001, Bosky Dell, Grant Avenue, Simon's Town, 7 September 1987. Syfrets Trust Ltd, 24 Wale Street, Cape Town.
- 5890/87—**Du Tolt**, Johannes Jacobus, 23 August 1898, Huis Jan Swart, Lourens River Road, Strand, 27 July 1987. Syfrets Trust Ltd, 24 Wale Street, Cape Town.
- 6380/87—**Ware-Lane**, Herbert William, 24 February 1929, 2902245038109, Southwinds, 6 Heather Lane, Kenridge, Durbanville, 21 August 1987; Mavis Ruth Ware-Lane. Syfrets Trust Ltd, 24 Wale Street, Cape Town.
- 7636/84—**Newmark**, Molly Doreen, born Ferris, 26 September 1902, 117907332, 2 Arrowhead, Ocean View Drive, Sea Point, 18 September 1984. Syfrets Trust Ltd, 24 Wale Street, Cape Town.
- 5258/87—**Nel**, Gideon Andreas, 15 November 1918, 1811155034001, Burgstraat 30 (a), Wellington, 9 Julie 1987; Catharina Hendrina Nel. Syfrets Trust Bpk., Waalstraat 24, Kaapstad.
- 6318/87—**Caswell**, Edward Thomas Joseph, 23 November 1940, 4011235049015, 23 Pers Road, Goolhurst Estate, Southfield, 14 Augusts 1987; Saretta Caswell, 30 April 1944, 4404300032018. Esau Shapiro, Isaacson & Burman, 145 Main Road, Claremont.
- 8308/85—**Van der Walt**, Wilhelmina, 27 May 1907, 45 Koorling Weg, Wheatfield, Crawford, 26 June 1979; Martin Arthur van der Walt, 11 June 1905, 0506115024016. Mallinick Ress Richman & Closenberg Inc., 6th Floor, 2 Long Street, Cape Town.
- 5216/87—**Jowell**, Rebecca, born Berelowitz, 10/9/01, 0109100007003, 102 Houghton Place, Norfolk Road, Sea Point, 14/7/87. Sonnenberg Hoffmann & Galombi, Liberty Life Centre, 22 Long Street, Cape Town.
- 6684/87—**Freidberg**, Maurice, 20/6/04, 0406205007007, 14 Pinewood Street, Somerset West, 31/8/87. Sonnenberg Hoffmann & Galombi, Liberty Life Centre, 22 Long Street, Cape Town.
- 6947/87—**Engelbrecht**, George Diederick, 4 April 1934, 3404045067007, 16 Dundas Crescent, Ruyterwacht, 8 September 1987. The Board of Executors, P.O. Box 86, Cape Town.
- 6469/87—**Robins**, Edith Marion, born Te Water, 5/11/1895, 9511050002002, Hampton House, Aliwal Road, Wynberg, 28/8/87. The Board of Executors, P.O. Box 86, Cape Town.
- 6503/87—**Adams**, Amina, 2/5/11, 38-16th Street, Kensington, 30/5/87. Mallinick Ress Richman & Closenberg Inc., Sixth Floor, 2 Long Street, Cape Town.
- 6946/87—**Burlak**, Marianna, 28 April 1905, 0504280020000, 4 Molteno Flats, 22 Molteno Road, Oranjezicht, 10 September 1987. Herbsteins, P.O. Box 1221, Cape Town.
- 5244/87—**Arendse**, Mildred Wilhelmina, born Fouten, 7/6/08, 0806170035018, Bethal Fourth Avenue, Retreat, 1/7/87. Cape Times, P.O. Box 11, Cape Town.
- 7028/87—**Caird**, Violet Daisy Gertrude, 30 June 1904, 0406300028007, Rosedale Home for the Aged, Kenilworth, 11 September 1987. Thompson Smithers & Bradley Inc., 102 Medical Centre, Maynard Road, Wynberg.
- 7087/87—**Thoresen**, George, 17/11/35, 3511175050007, Apiesdoringstraat 32, Uitbreiding 12, Mosselbaai, 3/9/87; Elzabe Thoresen, gebore Van Rensburg, 2/4/45, 4504020063001. Boland Bank Bpk., Posbus 373, George.
- 3607/86—**Lakey**, Joseph James, 29 Oktober 1912, 1210295043016, Lobeliastraat 25, Firgrove, 10 April 1986; Helena Maragret Lakey, 6 Februarie 1928, 2802060045017. Morkel & De Villiers, Posbus 43, Somerset-Wes.
- 5788/87—**Buhr**, Bregetta Elizabeth, (voorheen Rabie), gebore De Wet, 22/9/20, 2009220015001, A16 Groenvallei, Bellville, 4/8/87. Boland Bank Bpk., Posbus 48, Bellville.
- 3412/87—**Zaayman**, Dorothea Johanna Jacoba, 27/12/10, 1012270001005, Koopmanskraal, Poskantoor Windmeul, 15/12/86. J. D. Zaayman, Melkhoustraat 8, Kuilsrivier.
- 6653/87—**Prins**, Christoffel Everhardus, 30/12/13, 1312305003004, Lourensrivierweg 70, Strand, 1 September 1987. Rowan & Pullen, Barclays Bankgebou, Hoofweg, Strand.
- 6455/87—**Coetzee**, Hendrina Helena, 24/12/10, 1012240049001, Burchellstraat 11, Ruyterwacht, 18/7/87. Volkskustrust Bpk., Posbus 873, Bellville.
- 6615/87—**Bresler**, Daniel Henry, 11 Januarie 1904, 0401115017006, Griseldapark 7, Wingerdstraat, Somerset-Wes, 30 Augustus 1987; Magritha Aletta Bresler. S. A. P. Dreyer, Posbus 39, Strand.
- 6088/87—**De Kock**, Aurelia Augusta Geraldine, 12/11/1894, 9411120001003, Magnolia 73, Baxterstraat, Bellville, 19/7/87. Bankorptrust Bpk., Posbus 680, Bellville.
- 6635/87—**Feldmann**, Hans Heinrich Arnold, 10 Januarie 1894, 9401105008008, Môrewag, Posbus 2, Klapmuts, 26 Augustus 1987. Bankorptrust Bpk., Posbus 680, Bellville.
- 6743/87—**Fourie**, Adam Marthinus, 26/9/56, 5609265107006, Kempingel 5, Duynefontein, Melkbosstrand, 23/8/87; Hendrina Elizabeth Fourie, gebore Van Rensburg, 5312190044002. Bankorptrust Bpk., Posbus 680, Bellville.
- 6904/87—**Hendricks**, Clara, 25 Junie 1927, 2706250055019, Kerkstraat, Kylemore, 8 September 1987; Hendry Hendricks, 2609105080010. Bankorptrust Bpk., Posbus 680, Bellville.
- 6747/87—**Jacobs**, Frans Alexander, 28 Mei 1925, 2508255054009, Fairfieldstraat-Noord 150, Parow, 15 Augustus 1987; Martha Wilhelmina Jacobs, gebore De Beer, 3003270024004. Bankorptrust Bpk., Posbus 680, Bellville.
- 6750/87—**Koopman**, Cornelius, 14 Oktober 1929, 2910145055016, Buitekantstraat 230, Klawer, 18 Augustus 1987; Sophia Koopman, 3310280082017. Bankorptrust Bpk., Posbus 680, Bellville.
- 6910/87—**Louw**, Izak Daniel Petrus, 15 Maart 1887, 8703155001002, Sorgvliet, Calvinia, 9 Augustus 1987. Bankorptrust Bpk., Posbus 680, Bellville.
- 6152/87—**Saayman**, Elizabeth Helena Johanna, 4 September 1938, 3809040033004, Wesselstraat 42, Parow-Oos, 14 Augustus 1987; Jacobus Hendrik Saayman, 3407045006008. Bankorptrust Bpk., Posbus 680, Bellville.
- 6756/87—**Swart**, Cornelius Marthinus, 14 Januarie 1936, 3601155087002, Eastwoodstraat 12, Parowvallei, 17 Augustus 1987; Anna Dorothea Swart, gebore Pepler, 3602020076006. Bankorptrust Bpk., Posbus 680, Bellville.
- 6758/87—**Swart**, Pieter Jacobus, 6 Februarie 1938, 3802065002004, Volschenkstraat 12, De la Haye, 1 September 1987; Patricia Swart, gebore Smit, 4008170019003. Bankorptrust Bpk., Posbus 680, Bellville.
- 6634/87—**Van Daalen**, Patric Henry Ellis, 2 Maart 1927, 2703025003002, Bloekomlaan 19, Robertson, 14 Augustus 1987; Maria Ruby Gertruida van Daalen, gebore Du Plessis, 3110270051000. Bankorptrust Bpk., Posbus 680, Bellville.
- 6599/87—**Visser**, Johannes Lourens, 21 November 1927, 2711215007006, Orchardweg 7, Milnerton, 16 Augustus 1987; Dina Wilhelmina Elizabeth Visser, gebore Hanekom, 3010130040005. Bankorptrust Bpk., Posbus 680, Bellville.
- 6520/87—**Nel**, Elsie Sophia, gebore Dippenaar, 30/12/07, 0712300003001, Jessiestraat 16, Chrismar, Bellville, 26/8/87. Boland Bank Bpk., Posbus 48, Bellville.
- 6340/87—**Price**, Abraham, 23 Desember 1921, 2112235038016, Wandelstraat 312, Maskamsig, Vanrhynsdorp, 11 Augustus 1987; Annie Price, gebore Love, 3 Januarie 1930, 3001030065010. Le Roux & Van der Westhuysen, Posbus 1, Vanrhynsdorp.
- 6208/87—**Coetzee**, Karolus, 10 September 1965, 95 Soekmekaar, Macassar, 30 Maart 1987. Boland Bank Bpk., Posbus 56, Strand.
- 7037/87—**O'Grady**, Eileen Elizabeth, 23/6/21, 2106230033006, Hewatsingel 2, Somerset-Wes, 30/7/87. Murray Smith & Swanepoel, Posbus 32, Strand.

- 7044/87—**Van der Spuy**, Christina Maria, gebore Malan, 4/5/1899, 9905040005002, **Huis de Kuilen, Kuilrivier**, 31/8/87. Boland Bank Bpk., Posbus 236, Paarl.
- 6845/87—**De Jager**, Reinier Johannes Gerhardus, 15/12/1900, 0012155005007, **Gert Greeff-tehuis, Willowmore**, 25/7/87. De Jager & Vennote, Posbus 111, Willowmore.
- 3874/87—**Bigalke**, Michael Hermann, 12 March 1959, 5903155128002, Saaiplaas, P.O. Box 218, Ogies, 20 April 1987. R. C. Bigalke, 120 Merriman Avenue, Stellenbosch.
- 5146/87—**Gibbs**, Charles Jack, 6 June 1905, 0506065024107, 10 Hope Street, **Humers Home, Knysna**, 10 July 1987. Alwyn Burger & Co., P.O. Box 278, Knysna.
- 5350/87—**Van Rhyn**, Johannes Jacobus, 9 June 1916, 1606095035005, **Sunninghill Nursing Home, 5 Dordrecht Road, Milnerton**, 23 July 1987. Barclays National Bank Ltd, P.O. Box 512, Cape Town.
- 6090/87—**Landsman**, George, 20/1/1898, 9801205008008, 2 Queens House, Victoria Road, **Bantry Bay**, 16/8/87; Gladys Lillian Rose Landsman. Barclays National Bank Ltd, P.O. Box 512, Cape Town.
- 5448/87—**Kittow**, Mavis Carmen, 23/7/06, 0607230037006, Zerida Steyn, Forest Drive, **Pinelands**, 26/7/87. Barclays National Bank Ltd, P.O. Box 512, Cape Town.
- 4780/87—**Ball**, Elizabeth Anne Gertruida, 20/10/13, 1310200029009, 117 Nerina Gardens, **Fish Hoek**, 27/6/87. Barclays National Bank Ltd, P.O. Box 512, Cape Town.
- 6721/87—**Obholzer**, Eva-Marie Clarissa, 28/8/10, 1008280039001, 1 Wheelan Street, **Newlands**, 30/8/87. Barclays National Bank Ltd, P.O. Box 512, Cape Town.
- 5892/87—**Uys**, Johannes Nicolaas, 26/5/10, 1005265027001, **Van Riebeeckstraat 66, Heidelberg**, 7 Augustus 1987. Barclays-Nasionale Bank Bpk., Posbus 512, Kaapstad.
- 6457/87—**Krige**, Matheus Uys, 4/2/10, 1002045048001, Swartdakkies, **Proteastraat, Onrusrivier**, 10/8/87. Barclays-Nasionale Bank Bpk., Posbus 512, Kaapstad.
- 5916/87—**Van der Bank**, Daniel Philippus, 15/11/19, 1911155020008, **Spes Bona, Touwsrivier**, 4/8/87. Eerste Nasionale Bank Bpk., Posbus 512, Kaapstad.
- 6379/87—**Koegelenberg**, Petrus Johannes, 22 November 1941, 4111225037002, **Tweede Laan 1, Kleinzee**, 20 Augustus 1987; Jannetta Gesina Elizabeth Koegelenberg. Barclays-Nasionale Bank Bpk., Posbus 512, Kaapstad.
- 5970/87—**Bramwell**, Kenneth Robert Hartley, 18 September 1911, 1109185044003, 4b Corsair Way, **Sun Valley, Fish Hoek**, 11 August 1987; Rosalind Naomi Bramwell, 27 June 1921, 2106270056008. Barclays National Bank Ltd, P.O. Box 512, Cape Town.
- 6561/87—**De Villiers**, Charles Haupt (Carel Haupt), 4 Desember 1897, 9712045001006, **Strand**, 24 Augustus 1987. Barclays-Nasionale Bank Bpk., Posbus 512, Kaapstad.
- 5708/87—**Crook**, Edgar Norman, 19 Maart 1941, 4103195025000, **Porterstraat 61a, Worcester**, 4 Julie 1987; Susanna Edina Wilhelmina Crook, 7 Desember 1948, 4812070032002. Barclays-Nasionale Bank Bpk., Posbus 512, Kaapstad.
- Hoare**, Gladys Mary, 22 June 1904, 0406220014004, **Garden Gates, Main Street, Knysna**, 14 September 1987. First National Bank of S.A. Ltd, P.O. Box 164, Port Elizabeth.
- 3546/87—**Smith**, Daniel Jacobus, 14 Desember 1952, 5212145036006, **Martinstraat 23, Mafikeng, Bophuthatswana**, 13 Desember 1986. Bankorp-trust Bpk., Posbus 2144, Potchefstroom.
- 6209/87—**Van Eck**, Elizabeth Maria, 24 Maart 1893, 9303240001007, **Hesperos-ouetehuis, Beaufort-Wes**, 20 Julie 1987. John D. Crawford & Seun, Donkinstraat 36, Beaufort-Wes.
- 3684/87—**Thys**, Lucienne Marie Josephine, 1 Februarie 1912, 1202010034107, **Bordonweg 12, Rondebosch**, 7 April 1987; Maurits Hendrik Ermiel Thys. Smit Nel Kruger & Potgieter, Wellingtonweg 32, Durbanville.
- 6826/87—**De Klerk**, Pieter Johannes, 16/9/13, 1309165038005, **Soete Inval 8, Stellenbosch**, 21/8/87. Standardtrust Bpk., Posbus 1928, Bellville.
- 7011/87—**Kochman**, Ruth, 21 August 1917, 1708210032006, 1501 The Towers, **Holmfurth Road, Sea Point**, 3 September 1987. Standardtrust Ltd, P.O. Box 5562, Cape Town.
- 6716/87—**Joubert**, Johannes Jakobus, 29 May 1912, 1205295006005, **Huis Wittekruijn, Vredenburg**, 22 August 1987. Standardtrust Ltd, P.O. Box 5562, Cape Town.
- 6673/87—**O'Connor**, Hedley Phillip, 30 July 1909, 0907305016004, 44 **Eghamhof, Egham Road, Wynberg**, 24 August 1987. Standardtrust Ltd, P.O. Box 5562, Cape Town.
- 7084/87—**Srubinsky**, Joseph David, 28 Desember 1898, 9812285011002, **Highlands House, 234 Upper Buitekant Street, Cape Town**, 12 September 1987. Standardtrust Ltd, P.O. Box 5562, Cape Town.
- 6534/87—**Botha**, Christiaan Dewet, 27 August 1915, 1508275017003, 1 **Alladin Court, Norfolk Road, Lakeside**, 15 August 1987; Johanna Margaretha Botha. Standardtrust Ltd, P.O. Box 5562, Cape Town.
- 6926/87—**Faddell**, Richard Joseph, 27 June 1926, 2606275031005, 20 **Lee Road, Claremont**, 6 September 1987. Standardtrust Ltd, P.O. Box 5562, Cape Town.
- 6876/87—**Du Randt** (Du Rand), Willem Johannes, 29/10/1895, 9510295002009, **Chris Heunis Home, Somerset West**, 2/8/87; Euphemia Greig du Randt, born Grieve. Standardtrust Ltd, P.O. Box 5562, Cape Town.
- 7009/87—**Fulton**, Gwendoline Evelyn, 7 October 1921, 2 September 1987, **Bali Hai, Fishermans Bend, Sunset Rocks, Llandudno**, 2 September 1987. Standardtrust Ltd, P.O. Box 5562, Cape Town.
- 6980/87—**Beukes**, Gerhardus Johannes, 19/6/33, 3306195013006, 10de **Laan 186, Kraaifontein**, 28/8/87; Suanna Hendrina Beukes. Standardtrust, Posbus 1928, Bellville.
- 6999/87—**Rohde**, Johan Bugge, 8/4/14, 1404085031006, 25 **Montreux Street, Paarl**, 30/8/87; Anne Elizabeth Rohde, 6/5/21, 2105060036006. Standardtrust Ltd, P.O. Box 1928, Bellville.
- 6553/87—**Moradei**, Aldo, 26/2/08, 0802265019009, **Babylonstoring, Klappmuts**, 27/7/87. Standardtrust Bpk., Posbus 1928, Bellville.
- 6677/87—**Viljoen**, Barend Burger, 23/12/03, 0312235007001, **Frederikstraat 2, Durbanville**, 10/8/87. Standardtrust Bpk., Posbus 1928, Bellville.
- 6838/87—**Voges**, Jacob Johannes, 5/7/46, 4607055066003, **Van Rensburgstraat 84, Goodwood**, 26 Augustus 1987; Elizabeth Francina Voges, gebore Odendaal, 4505170059004. Bankorp-trust Bpk., Posbus 680, Bellville.
- 5556/87—**Cauvin**, Engela Hester Cecilia, born De Lange, 13 January 1902, 0201130001005, **Zerilda Steyn Memorial, Pinelands**, 14 July 1987. Bankorp-trust Ltd, P.O. Box 680, Bellville.

NOORD-KAAP • NORTHERN CAPE

- 842/87—**Le Roux**, Hermanus Engelbrecht, 3 Mei 1907, 0705035012008, **Magadien, Pk. Van Zylsrus**, 30 Augustus 1987. A. N. P. Lubbe, **Polarislaan 517, Waterkloofrif, Pretoria**.
- 810/87—**Rossouw**, Gert Adolf, 1 Oktober 1912, 1210015016003, **McKenziestraat 169, Vryburg**, 27 Junie 1987; Carolina Frederika Christina Rossouw, 9 September 1918, 1809090009005. C. J. Rossouw, Posbus 23309, **Bedworth Park**.
- 776/87—**Groenewald**, Pieter Gerhardus du Bruyn, 27 Januarie 1944, 4401275026009, **Irene Marydale**, 27 Mei 1987. Petrus J. Muller & Kie., Posbus 37, **Prieska**.
- 872/87—**Vlok**, Martha, 30 Mei 1916, 1605300067001, **Bloubosfontein, distrik Griekwastad**, 20 Augustus 1987. Volkskastrust Bpk., Posbus 602, **Kimberley**.

- 751/87—**Van Zyl**, Susanna Adriana, 15/10/32, 3210150009001, Leeuvlei, distrik Griekwastad, 16/8/87; Susanna Adriana van Zyl, 15/10/32, 3210150009001. Eerste Nasionale Bank Bp, Posbus 1014, Kimberley.
- 854/87—**Rossouw**, Heremias Cornelius, 27 Junie 1901, 0106275003007, Murray, Askham, 21 Augustus 1987; Elizabeth Gertruida Rossouw. Malan & Vennote, Posbus 27, Upington.
- 841/87—**Human**, Andries Adriaan Stefanus, 27 Januarie 1906, 0601275004005, Diepte, Vanzylsrus, 16 Augustus 1987. Volkskastrust Bpk., Posbus 602, Kimberley.
- 849/87—**Southall**, Harold Vivian Horace, 18 November 1913, 1311185015003, Breestraat 5, Philipstown, 14 September 1987. Joseph & Van Rensburg, Posbus 139, De Aar.
- 804/87—**Hoelson**, Norman Hook, 6 October 1919, 1910065008004, 26 Egerton Road, Kimberley, 26 August 1987. Standardtrust Ltd, P.O. Box 288, Kimberley.
- 829/87—**Coetzee**, Johannes Cornelius Jacobus, 22 Desember 1933, 3312225037007, Millerstraat 49, De Aar, 3 September 1987; Patsy Coetzee. Standardtrust Bpk., Posbus 288, Kimberley.
- 811/87—**Rust**, Henning Jacobus Human, 7/4/07, 0704075004009, Huis Frieda Kempen, Commercialweg, Victoria-Wes, 17 Augustus 1987. Kempen & Kempen, Posbus 24, Victoria-Wes.
- 837/87—**Honiball**, Bertie, 27 Februarie 1921, 2102275042002, Lornaweg 9, Kimberley, 4 September 1987; Wilhelmina Johanna Honiball, 1 Maart 1922, 2203010025003. Bertie Honiball, p/a Coetzee & Honiball, Stockdalestraat 14, Kimberley.

OOS-KAAP • EASTERN CAPE

- 1396/87—**Fisher**, Edith Grace, 5 May 1907, 0705050041007, 529 Vincent Park Centre, East London, 14 May 1987; Albert Hubert Pheens Fisher, 25 June 1911, 1106255033007. Desmond Terence Brasseill, 612 Kennaway Court, Inverleith Terrace, East London.
- 2669/87—**O'Shea**, Sheila Margaret, 16 October 1934, 3410160064000, 91 Main Road, Walmer, Port Elizabeth, 7 August 1987; Denis Patrick O'Shea. Jassinowsky & Shear, P.O. Box 790, Port Elizabeth.
- 2849/87—**Slabbert**, Petrus Gerhardus, 19 Julie 1913, 1307195009004, Jansenville, 21 Augustus 1987. Volkskastrust Bpk., Posbus 1493, Port Elizabeth.
- 2725/87—**Sauer**, Stefanus Johannes, 6 April 1927, 2712050017001, Oos-Londen, 20 Augustus 1987; Johanna Helena Sauer, gebore Rossouw, 5 Desember 1927, 2712050017001. Volkskastrust Bpk., Posbus 1493, Port Elizabeth.
- 2859/87—**Hübsch**, Florence Maud, 17/11/06, 0611170009009, Rosa Munch, Uitenhage, 16/9/87. Boland Bank Bpk., Posbus 55, Uitenhage.
- 2901/87—**Van der Merwe**, Susanna Catherina, formerly Ferreira, born De Lange, 6/12/08, 0812060003009, 36 Beaufort Street, Grahamstown, 8/9/87; Izak Zerk van der Merwe, 22 October 1918, 1810225007005. Wheelton Rushmere & Cole, 119 High Street, Grahamstown.
- 2610/87—**Verster**, Jacobus Pieter, 21 Junie 1928, 2806215064005, Rosedale, Addo, 16 Augustus 1987. K. P. Meiring, Posbus 128, Kirkwood.
- 2862/87—**Louw**, Arnoldus Herold, 13/10/10, 1010135015004, D'Urban Roaw, Colesberg, 4 September 1987. Schutz & De Jager, P.O. Box 3, Colesberg.
- Williamson**, Wallace John, 21 December 1923, 2312215037109, 41 Amsterdamhoek Road, Amsterdamhoek, Port Elizabeth, 16 September 1987. First National Bank of S. A. Ltd, P.O. Box 164, Port Elizabeth.
- Fife**, Stanley Ernest, 1915-02-15, 1502155012002, 23 Gerald Street, Newton Park, Port Elizabeth, 1987-09-25; Maria Francis Fife, born Volker, 1923-01-10, 2301100008002. First National Bank of S A Ltd, P.O. Box 164, Port Elizabeth.
- Kershaw**, Gladys Victoria, born Gibbins, 22 January 1901, 0101220002006, 2 Harrodene, Fourth Avenue, Summerstrand, Port Elizabeth, 16 September 1987. First National Bank of S.A. Ltd, P.O. Box 164, Port Elizabeth.
- 2899/87—**Joffe**, Jacob, 1902-12-31, 0212315018003, 2 Fifth Avenue, Summerstrand, Port Elizabeth, 1987-09-17. Fisher Hoffman Stride, P.O. Box 1552, Port Elizabeth.
- 2757/87—**Janse van Rensburg**, Nicolaas Lodewyk, 28/7/46, 4607285054001, Hawthornelaan 49, Framesby, Port Elizabeth, 23/8/87; Linda Louise Janse van Rensburg, 15/2/51, 5102150044005. Burmeister & Lamprecht, 12 Graham Street, North End, Port Elizabeth.
- 2616/87—**Hill**, Ivan Jesse, 31/11/16, 1601305025003, Komani Hospital, Queenstown, 30/8/87. Marshall & Kaplan, P.O. Box 183, East London.
- 2810/87—**Heppell**, Archibald Raymond Maxmillan, 21/8/06, 0608215018003, 8 Dawson Road, Selborne, East London, 24/8/87. Price Waterhouse, P.O. Box 810, East London.
- Anderson**, Neville Haig, 8 October 1917, 1710085047002, 24 Beau Vallon, St George's Road, Southernwood, East London, 20 September 1987; Violet Anderson, born Ashwell, 28 February 1919, 1902280041001. First Personal Asset Management, P.O. Box 1537, East London.
- 2739/87—**Basson**, Cyril Kenneth, 24/2/24, 2402245047002, Nuwestraat 13, De Mist, Uitenhage, 30/8/87; Cecilia Gesina Basson, gebore Swane-poel, 8/11/26, 2611080043005. Bankoprtrust Bpk., Posbus 1199, Port Elizabeth.
- 2897/87—**Van der Walt**, Hendrik Johannes, 13/2/38, 3802135009005, Victoriastraat 7, Uitenhage, 6/9/87; Elsie Johanna van der Walt, gebore Coertzen, 27/11/42, 4201270043003. Bankoprtrust Bpk., Posbus 1199, Port Elizabeth.
- 2489/87—**Van Greunen**, Louis Willem, 5/5/08, 0805055033007, Pro Ecclesiawoonstelle 4, Uitenhage, 30/7/87; Christina Wesselina van Greunen, 25/1/15, 1501250036007. Bankoprtrust Bpk., Posbus 1199, Port Elizabeth.
- 2607/87—**Potgieter**, Daniel, 19/4/31, 3104195049009, Amperbostraat 47, Despatch, 12/8/87; Edith Mary Potgieter, 5/11/30, 3011050053002. Bankoprtrust Bpk., Posbus 1199, Port Elizabeth.
- 1496/87—**Jonas**, Johannes, 3 November 1923, 2311035042018, Petrusstraat 12, Somerset-Oos, 26 Februarie 1987; Rosie Jonas, gebore Welman, 101192621. Volkskastrust Bpk., Posbus 1493, Port Elizabeth.
- 2454/87—**Harper**, William Henry Mervyn, 14 March 1908, 101682789W, Lorraine Residensie, Sedan Road, Lorraine, Port Elizabeth, 24 July 1987; Christina Phail Anderson Harper, formerly Hales, born Ferguson, 22 August 1903, 101682790W. Brown Braude & Vlok, P.O. Box 3073, Port Elizabeth.
- 2321/87—**Lombard**, Cornelius Petrus, 9 November 1930, 3011095074005, 27 Heron Street, Port Alfred, 8 June 1987; Norma June Lombard, 3812120099002. Dold & Stone, 100 High Street, Grahamstown.
- 2800/87—**Osborn**, John Lindon, 14/2/16, 1602145011005, 30 De Smidt Street, Cathcart, 7/9/87. Elliotts, P.O. Box 5, Cathcart.
- 2967/87—**Spence**, Cecil Ainslie, 31 December 1920, 2012315017007, 2 Hinton court, Webb Street, East London, 21 September 1987. Bate Chubb & Dickson Inc., Permanent Building, 42 Terminus Street, East London.
- 1844/87—**Wilson**, Iris Noel, 19 December 1905, 0512190016000, 39 Woolhope Road, Westering, Port Elizabeth, 16 June 1987. Standardtrust Ltd, P.O. Box 329, Port Elizabeth.
- 2688/87—**Manley**, Luck Sing, 14 September 1987, 1509145036041, 50 Bains Road, Uitenhage, 24 June 1987; Ho May Manley. Sellick & McIntyre, P.O. Box 94, Uitenhage.
- Du Preez**, Gert Wilhelmus, 19 September 1921, 2109195016008, Hoofweg 46, Gonubie, distrik van Oos-Londen, 20 September 1987; Johanna Adriaana du Preez, 3008130022007. Standardtrust Bpk., Posbus 996, Oos-Londen.
- 2418/87—**Keyser**, Weber Cecil, 14 November 1925, 2511145001008, Beaufortstraat 10, Uitenhage, 6 Junie 1987. Kitchings, Posbus 136, Uitenhage.
- 2775/87—**Williams**, Tobias Johannes, 4 April 1909, 0904045008003, Aberdeen, 28 Julie 1987. Volkskastrust Bpk., Posbus 1493, Port Elizabeth.
- 2752/87—**Klee**, Dorothy Mary, formerly Clarke, born Daniel, 10/10/1896, 9610100002002, 23 Albert Street, Queenstown, 21/8/87. C. S. Fiveash & Marsberg, P.O. Box 986, Queenstown.
- 2733/87—**Warkus**, Ronald Theo, 4/4/13, 1304045016008, 37 Arthur Street, King Williams Town, 23 August 1987. Edna Joyce Warkus, 2 December 1918, 1812020020001. Hutton & Cook, P.O. Box 44, King William's Town.

- 2024/87—**Muller**, Norman Hilgard, 17 Februarie 1921, 2102175003005, St Leonardweg 36, Algoapark, Port Elizabeth, 25 Junie 1987; Violet Muller, 7 Oktober 1923, 2310070045001. Hein Nel & Vennote, Hoofstraat 1 Ic, Humansdorp.
- 2750/87—**Kemp**, Joseph, 13 Oktober 1919, 1910135008000. Safferystraat 8, Humansdorp, 18 Mei 1987; Helena Susanna Petronella Fredrika Kemp, 27 Desember 1922, 2212270017006. Steyn & Van der Vyver, Posbus 3, Willowmore.
- 2569/87—**Shefer**, Berenice, 28 August 1939, 3908280046005, 193 Cape Road, Port Elizabeth, 19 June 1987. Mrs F. Katz, P.O. Box 12080, Centrahil.
- Henning**, Cornelia Magdalena Petronella, born Oelofse, 5 November 1905, 0511050004007, 65 Smith Street, Alice, 14 January 1987; Frans Johannes Henning, 1105045004005. Standardtrust Ltd, P.O. Box 996, East London.
- 2712/87—**Wiggins**, Edgar Albert, 22 January 1907, 0701225021008, 28 Ralston Road, Fernglen, Port Elizabeth, 24 August 1987; Cecilia Marthaltida Wiggins, born Johnson, 21 September 1916, 1609210021009. Fidelity Bank Ltd, 190 Main Street, Port Elizabeth.
- 1899/87—**Opperman**, Christine Magdelene, 25 July 1933, 3307250036007, 59 Strand Street, West Bank, East London, 6 October 1986; Charles Frederick Opperman, 9 March 1928, 2803095045006. Bradfield Archer & O'Connor, First Floor, United Building, 58 Terminus Street, East London.
- 1908/87—**Usher**, Irad Rio, 22 December 1906, 061222502828002, 59 Alfred Street, Stutterheim, 17 April 1987; Maggie Doreen Usher, born Moncur, 11 March 1912, 1203110029005. Bradfield Archer O'Connor & Cocks, Third Floor, First National Bank Building, Union Street, East London.
- 1393/87—**Els**, Hannah Rebecca, 10 July 1916, 1607100010009, 2 Vere Road, Southernwood, East London, 15 December 1986; Johannes Marthinus Els, 20 September 1911, 1109205010000. Bradfield Archer O'Connor & Cocks, Third Floor, First National Bank Building, Union Street, East London.
- 2495/87—**Bertenshaw**, Thomas Frederick, 10 March 1909, 0903105024009, 58 Church Road, Walmer, Port Elizabeth, 13 August 1987. Arderne Lifson & Hanekom, P.O. Box 457, Port Elizabeth.
- 2821/87—**Shryane**, Philip Lawley, 19 November 1915, 1511195017004, 9 Avocet, The Strand, Swartkops, Port Elizabeth, 31 August 1987. Standardtrust Ltd, P.O. Box 329, Port Elizabeth.
- 2850/87—**Souter**, James, 15 April 1900, 8 Chapman Road, Claredon Marine Seaview, Port Elizabeth, 2 September 1987. Standardtrust Ltd, P.O. Box 329, Port Elizabeth.
- 2925/87—**Camons**, Ronald Charles Joseph, 2 October 1928, 2810025044009, 8 Holmes Street, Uitenhage, 15 September 1987. Sellick & McIntyre, P.O. Box 94, Uitenhage.
- 2554/87—**Steyn**, Diederik Jakobus, 28/6/35, 3506285003003, c/o Rusoord, Private Bag Meisieshalt, East London, 17/8/87. Bankorptrust Ltd, P.O. Box 2174, Durban.
- 2787/87—**Le Roux**, Jacobus, 31/3/1892, 9203315004003, Kamer 26, Thompson Huis, Fairhoven, Port Elizabeth, 30/8/87. Boland Bank Bpk., Posbus 55, Uitenhage.
- 2808/87—**Donaldson**, Ellen May, 16 May 1904, 0405160013000, 18 Campbell Street, Port Alfred, 23 August 1987. D. J. Malan, P.O. Box 247, Port Alfred.
- 2793/87—**Forbes**, Mary Thornhill, 1901-11-09, 0111090003000, Craigievar, Burgersdorp, 30 Augustus 1987. Hanekom & Bester, Posbus 19, Burgersdorp.
- 2463/87—**Ewels**, Eunice Patricia, 17 March 1913, 1303170030008, 1 Constantia Court, St James Road, East London, 2 August 1987. Syfrets Trust Ltd, P.O. Box 466, Port Elizabeth.
- 2852/87—**Barnes**, Roger Hudson, 2 November 1904, 0411025013003, Park Towers, Rink Street, Port Elizabeth, 19 August 1987. Syfrets Trust Ltd, P.O. Box 466, Port Elizabeth.

NATAL

- 5905/87—**Norton**, Grace Beatrice, 3/8/05, 0508030010005, 1 Whispers, 8 St Patrick Road, Pietermaritzburg, 7/9/87. Pim Goldby, P.O. Box 310, Pietermaritzburg.
- 5845/87—**Chetty**, Parmasvan, 11/9/37, 3709115074059, 17 Granadilla Crescent, Northdale, Pietermaritzburg, 2/8/87; Lutchmidevi Chetty, 14/12/42, 4212140056059. A. K. Essack, Morgan Naidoo & Co., 520 Pietermaritz Street, Pietermaritzburg.
- 4674/87—**Bennewith**, Muriel Caroline, 23 October 1906, 0610230019008, Westhaven, P.O. Claridge, 20 July 1987. Livingston Doull & Winterton, P.O. Box 180, Durban.
- 5784/87—**Douglas**, Beryl, 26 October 1919, 1910260005003, 4 Fairways, Alexander Road, Pietermaritzburg, 2 September 1987. Standardtrust Ltd, P.O. Box 917, Pietermaritzburg.
- 5285/87—**Coetzer**, Elfrieda Nancy, 30/9/15, 1509300046009, Cromwellweg 20, Glenwood, Durban, 20 Julie 1987. Volkkskastrust Bpk., Posbus 918, Pietermaritzburg.
- 5729/87—**Potgieter**, Ockert Johannes, 12/3/16, 1603125019000, Markstraat 15, Paulpietersburg, 24 Augustus 1987; Helena Petronella Potgieter, 7/2/20, 2002070005008. Volkkskastrust Bpk., Posbus 918, Pietermaritzburg.
- 5900/87—**Jordaan**, Anna Susanna, 22/2/28, 2802220011008, Dagbreek 6, distrik Vryheid, 27 Augustus 1987; Lodiwikus Johannes Jordaan, 11/2/24, 2402115014009. Volkkskastrust Bpk., Posbus 918, Pietermaritzburg.
- 5387/85—**De Lange**, John Frederik, 12 August 1953, 5308125017006, House 22, Durnacol, 9 January 1985. Du Toit & Partners, P.O. Box 36, Newcastle.
- 5645/87—**Murdoch**, Alan Kay, 22 June 1925, 2506225058100, 50 Berg Road, Hilton, Pietermaritzburg, 12 July 1987. Volkkskastrust Ltd, P.O. Box 61488, Marshalltown.
- 5717/85—**Sethuntsa**, Langa Khotso, 17/12/49, Houston Farm, Cedarville, District of Matatiele, 24/12/81. Elliot & Walker, P.O. Box 17, Kokstad.
- 5373/87—**Killips**, Cecil, 11/11/12, 1211115016000, Mimosa, Ladysmith, 11 August 1987. A. M. Mortimer & Co., P.O. Box 972, Ladysmith.
- 3910/87—**Alwar**, Perumal, 25 January 1925, 2510155066059, 72 Durban Street, Greytown, 8 June 1987. Nel & Stevens, P.O. Box 60, Greytown.
- 5103/87—**Colenbrander**, Ralph Brunner, 24/11/14, 1411245015001, Farm Goedgelooft, District of Vryheid, 4/8/87. Cox & Partners, P.O. Box 5, Vryheid.
- Spooner**, Elizabeth, 31 May 1913, 1305310023009, Pietermaritzburg, 25 August 1987. Shepstone & Wylie, Tomlinson Francis, P.O. Box 271, Pietermaritzburg.
- 5576/87—**Budhal**, Awtari, 5 November 1931, 3111055075057, 43 Burma Road, Ladysmith, 19 August 1987; Lutchmee Budhal, 7 October 1937, 3710070096053. A. Sibran & Associates, P.O. Box 639, Ladysmith.
- 5435/87—**Jefferies**, Harold Edgar, 12 March 1902, 0203125007005, Sandy River, Richmond, 7 August 1987. McCann & Nicholson, P.O. Box 4, Richmond.
- 109/87—**Lona**, Deryck Hylton, 5 February 1951, 5102055067002, 3 Chapel Court, Chapel Street, Overport, Durban, 5 January 1987. Lander & Tomlinson, P.O. Box 87, Westville.
- 2663/86—**Murugammal**, during May 1901, 800366052A, 310 Montdene Drive, Croftdene, Chatsworth, 5/1/84. Zubeda K. Seedat & Co., Suite 52, KMS House, 173 Grey Street, Durban.
- 5847/87—**Govender**, Muthusamy, 29 May 1942, 4205295077052, 75 Eagle Drive, Flamingo Heights, Tongaat, 12 August 1987; Panjalay Govender, 14 February 1948, 4802140115051. Bala Naidoo & Co., 12 Luxmi Court, 312 Main Road, Tongaat.
- 3605/87—**Selling**, Agnes Margaret, 16 June 1918, 1806160063011, 67 Wolraad Road, Austerville, 15 March 1987; since deceased Alec Selling, 30 June 1916, 1606305033014. Shun Pillay, 14/16 Junaid Centre, 4 Bond Street, Durban.

- 5892/87—**Crawford**, Harold, 30/12/04, 0412305014000, 30 Adams Road, Amanzimtoti, 6/9/87. M. J. R. Castleden, P.O. Box 2806, Durban.
- 5549/87—**Naismith**, Moira (Moria) Caldwell, 5 March 1919, 1903050023005, Benderloch Farm, Port Edward, 28 July 1987. Standardtrust Ltd, P.O. Box 2743, Durban.
- 5704/87—**Baxter**, Cyril, 6/7/30, 3007065001003, 11 Abington Road, Umtentweni, 14/8/87. Standardtrust Ltd, P.O. Box 2743, Durban.
- 4187/87—**Lombard**, Patricia Brenda, 5 July 1930, 3007050083007, 26 Palm Springs, Park Road, Malvern, Durban, 30 May 1987; Colin Chipps Lombard. Standardtrust Ltd, P.O. Box 2743, Durban.
- 5727/87—**Ndlovu**, Bekuyise Jonathan, 29/3/42, 138439307, Ivuma Store, Nongoma, 6 August 1987. Standardtrust Ltd, P.O. Box 2743, Durban.
- 6063/87—**Cumming**, Lulu Elizabeth, 24 August 1915, 1508240038001, 309 Pioneer Lodge, 49 Tyzack Street, Durban, 10 September 1987. Clemmans & Johnston Inc., P.O. Box 598, Durban.
- 5703/87—**Amurthavalee**, 11/1/22, 800494390A, 15 Peachside Avenue, Unit 20, Phoenix, 25/8/86. Patterson & Manikam, P.O. Box 5691, Durban.
- 6166/87—**Dunn**, John Angus, 28/6/07, 0706285017002, Brooklands Farm, Shakaskraal, 24/9/87. Legator, McKenna Inc., P.O. Box 2385, Durban.
- 6005/87—**Essery**, Marian Vacy, 15 May 1914, 1405150011005, 31 Stranack Road, Glenwood, Durban, 14 September 1987. Livingston Doull & Winterton, P.O. Box 180, Durban.
- 5271/87—**Thomas**, Ramachandra, 8 August 1921, 2108085057056, 3 Barton Place, Clare Estate, Durban, 23 August 1987. Amin & Trikamjee, P.O. Box 48301, Qualbert.
- 5218/87—**Whysall**, Dorothy Hope, 4 June 1905, 0506040019008, 25 Grosvenor Crescent, Durban North, 15 August 1987. S. R. D. Brooks, 14th Floor, 88 Field Street, Durban.
- 5887/87—**Arntzen**, Jeanetta Wilhelmina, 1 October 1904, 0410010006006, Musgrave Nursing Home, 184 Musgrave Road, Durban, 5 September 1987. Marriott & Brodie, P.O. Box 1465, Durban.
- 2567/87—**Majola**, Fred, 510950459, c/o Amaoti B.C. School, P.O. Inanda, District of Inanda, 13 December 1965. C. Sewpershad & Co., P.O. Box 161, Verulam.
- 5888/87—**Cawood**, Ernest Adrian, 19/11/17, 1711195036, 21 Alpine Way, Uvongo Beach, 29/8/87. Standardtrust Ltd, P.O. Box 2743, Durban.
- 5463/87—**Hill**, Elnaura, 12 February 1923, 2302120057003, 14 Voortrekker Street, Pinetown, 22 August 1987. Standardtrust Ltd, P.O. Box 2743, Durban.
- 5386/87—**Stoltz**, William Meyer, 24/2/04, 0402245005002, 13a Queen Elizabeth Drive, Manaba Beach, Uvongo, 11/8/87; Edith Doreen Stoltz.
- 5860/87—**Fenn**, Kathleen Margaret Mary, 27 September 1911, 1109270038001, 9 Hertine Court, St Andrews Street, Durban, 5 September 1987. Standardtrust Ltd, P.O. Box 2743, Durban.
- 5830/87—**Papapanayotou**, Antoine, 8/3/16, 1603085049104, 55 Cavell Place, Umbilo, Durban, 13/8/87; Efthymia Papapanayotou, 26/5/18, 1805260037107. Barclays National Bank Ltd, P.O. Box 3409, Durban.
- 5295/87—**Pitt**, Joyce Irene, 26/10/22, 2210260006005, 53 Rapson Road, Morningside, Durban, 9/8/87. Barclays National Bank Ltd, P.O. Box 3409, Durban.
- 5702/87—**Wakeford**, Richard Howard Bernard, 11/3/40, 4003115049009, 13 Henry Fynn Road, Pinetown, 2/9/87. Bankortrust Ltd, P.O. Box 2174, Durban.
- 5902/87—**Lilly**, John Horsten, 6/9/04, 0409065001003, Braemore Nursing Home, Fairley Crescent, Pinetown, 31/8/87. Bankortrust Ltd, P.O. Box 2174, Durban.
- 5820/87—**Coad**, William Ralph, 15/5/22, 2205155028007, 12 Wescott Road, Westville, 28/8/87; Yvonne Coad, 2/2/30, 3002020029008. Shepstone & Wylie, 41 Acutt Street, Durban.
- 5759/87—**Da Silva**, John Henry, 6 February 1942, 4202065021006, Lot 601, Palm Street, Shelly Beach, 26 June 1987. Arthur Young & Company, P.O. Box 31740, Braamfontein.
- 1911/87—**Gevisser**, Eugene Leslie, 19 January 1920, 2001195003005, 1 Brilyn, 176 Springfield Road, Durban, 12 February 1987. Meskin & Levy, P.O. Box 2497, Durban.
- 1934/87—**Bilewicz**, Helen, 18 August 1903, 0308180036003, 5 Sharon, 250 Mountpelier Road, Morningside, Durban, 7 March 1987. Jayne Lindemann, P.O. Box 4810, Durban.
- 5828/87—**Moodley**, Munsami, 7 October 1914, 1410075037051, 49 Chiltern Road, Shallcross, 7 July 1987; Govindama Moodley, 7 June 1915, 1506070042051. K. Reddy & Company, Suite 77, Phoenix Centre, 3334 Old North Coast Road, Mount Edgecombe.
- 2235/87—**Thathlah**, Venketsamy Parasurama, 11/11/44, 441115093051, 27 Tensing Road, Naidooville, Umkomaas, 29/3/87. Ditz Incorporation, 50 Masonic Grove, Durban.
- 5635/87—**Allentop**, Elsie Getrude, 27/10/1889, 903520152W, Apartment 54, Astra Hotel, Russell Street, Durban, 16/8/87. Barclays National Bank Ltd, P.O. Box 3409, Durban.
- 5714/87—**Grant**, Grace Katherine, 8/6/08, 0806080009004, The Astra, Russell Street, Durban, 2/9/87; Kenneth William Grant, 9/10/21, 2110095001082. Barclays National Bank Ltd, P.O. Box 3409, Durban.
- 5125/87—**Van Tonder**, Wilhelm Petro, 26/12/30, 3012265004004, 58 Grenville Road, Grosvenor, Bluff, Durban, 17/7/87; Agada Catharina van Tonder, 27/2/34, 3402270045003. Bankortrust Ltd, P.O. Box 2174, Durban.
- 5915/87—**Swart**, Leonard, 12/3/39, 3903125061004, 27 Bauchinia Bend, Arboretun, Richards Bay, 12/7/87; Hester Catharina Swart, 25/6/47, 4706250098009. Bankortrust Ltd, P.O. Box 2174, Durban.
- 5489/87—**Arnulphy**, Louis Jacques Serge, 21/7/26, 2607215021106, 24 Sandyville, Crart Avenue, Glenwood, Durban, 23/8/87. Barclays National Bank Ltd, P.O. Box 3409, Durban.
- 5911/87—**Robinson**, Josephine Helena, 20/5/1900, 0005200010006, 41 Constantia, St Georges Street, Durban, 5/9/87. Barclays National Bank Ltd, P.O. Box 3409, Durban.
- 5821/87—**Crawford**, Olive Mabel, 20/9/1887, 970920008008, 17 Burns Road, Hayfields, Pietermaritzburg, 18/8/87. Syfrets Trust Ltd, P.O. Box 135, Durban.
- 5158/87—**Limbada**, Suleman Mahomed, 28 February 1911, 1102285050053, 11 Rainforest Place, Rainham, Phoenix, 2 August 1987; Mariam Suleman Limbada, 6 July 1936, 800391145A. Mariam Suleman Limbada, 11 Rainforest Place, Rainham, Phoenix.
- 5890/87—**Blackhurst**, Stella Hope Frances, 21/5/12, 1205210001008, Hillandale, P.O. Inchanga, 18/8/87. Barclays National Bank Ltd, P.O. Box 3409, Durban.
- 5816/87—**Allen**, Elaine Rose, 3/8/19, 1908030024007, 5d Wilhelmina Cottage, Natal Settlers Home, 17 Hutcheson Road, Durban, 24/8/87; George Allen, 10/6/15, 1506105030006. Barclays National Bank Ltd, P.O. Box 3409, Durban.
- 5684/87—**Subramoney** (Subramoney Pillay), 1 January 1936, 3601015068051, 233 Rojah Road, Darnall, 11 August 1987; Poobathy Subramoney, 2 November 1944, 4411020143058. Bala Govender, Pat Naidoo & Company, P.O. Box 91, Stanger.
- 5529/87—**Harisingh** (Harisingh Jawahir), 10 July 1937, 800355621, Asherville, 25 August 1987; Surajudae Harisingh, 1 September 1933, 800164121. Bala Govender, Pat Naidoo & Company, P.O. Box 91, Stanger.
- 5929/87—**Khan**, Mujawat, 8/4/45, 4504085079958, 144 Greendale Road, Silverglen, Durban, 17/6/87; Priscilla Ann Khan. Sayed & Lockhat, 1003 Nedbank House, 30 Albert Street, Durban.

- 4148/87—**Pile**, George, 21/4/07, 0704215026003, 5 Diagonal Street, Ramsgate, 11/5/87. N. J. Morris, P.O. Box 47, Johannesburg.
- 4876/87—**Van Kooten**, Elizabeth, 25/11/08, 0811250022100, 28 Becton Drive, Queensburgh, 24/7/87. Syfrets Trust Ltd, P.O. Box 135, Durban.
- 4965/87—**MacDonald**, Marjorie, 4/12/04, 0412040021005, 91 Broadwindsor, Broad Street, Durban, 2/8/87. Barclays National Bank Ltd, P.O. Box 3409, Durban.
- 5914/87—**Sjoberg**, Alan Oscar Cyril Bell, 28/7/1894, 9407285009005, 46 Park Lodge Gardens, Berea Road, Durban, 21/8/87. Barclays National Bank Ltd, P.O. Box 3409, Durban.
- 5713/87—**Gerber**, Frans Anthonie, 8/7/10, 1007085030009, 59 Buckingham Road, Kloof, 29/8/87. Barclays National Bank Ltd, P.O. Box 3409, Durban.
- 5475/87—**Schwartzel** (Donal Richards), Donal (Donald), 30/7/22, 2207305090085, 31 Hughlyn, 43 Mona Road, Durban, 25/8/87. Syfrets Trust Ltd, P.O. Box 135, Durban.
- 5683/87—**Spears**, Phyllis Elizabeth, 31/3/12, 1203310029003, 72 Wynwood, St Andrews Street, Durban, 27/8/87. Barclays National Bank Ltd, P.O. Box 3409, Durban.
- 5867/87—**Stone**, Gladys Gwendoline, 9/6/10, 1006090007004, 1 Sport Road, Manor Gardens, Durban, 4/9/87. Barclays National Bank Ltd, P.O. Box 3409, Durban.
- 5353/87—**Herbert**, Maria Alazina, 1931-02-13, 3102130063010, 283 Randles Road, Sydenham, Durban, 30/7/87; Donald Wilson Herbert, 27/7/32, 3207275052015. R. B. Lalla & Co., P.O. Box 48390, Qualbert.
- 4531/87—**Buthram**, Heeralall, 22 April 1943, 800184154A, 2 Jacaranda Avenue, Mount View, Verulam, 19 April 1987; Radha Buthram, 800143085A. Suren Lutchman, Vallaraman & Company, P.O. Box 1205, Verulam.
- 5768/87—**Seedat**, Hawa Bee Bee, 17/1/29, 800465156A, Lenasia, Johannesburg, 1/1/87. Mooney, Ford & Partners, 15 Hermitage Street, Durban.
- 4946/87—**Saib**, Shariffa Bi, 29 March 1916, 800493321, 55 Kolwa Road, Verulam, 5 November 1986. Suren Lutchman, Vallaraman & Co., P.O. Box 1205, Verulam.
- 4870/87—**Dawood**, Abdulla, 18/11/43, 4311185120059, 35 Ainsbury Place, Eastbury, Phoenix, 25 April 1987; Christina Cynthia Dawood, 24 April 1944, 800125464A. Renuka Singh & Company, 205 Dinesh Centre, 25 Bond Street, Durban.
- 5832/87—**Pillay**, Nadasin, 31/10/34, 3410315066058, House 119, Road 229, Bayview, Chatsworth, 21 June 1987; Chellamma Pillay, 19 February 1942, 4202190087054. Himal Tugh & Company, P.O. Box 45301, Chatsglen.
- 5978/87—**Mabesh**, Ranjith, 1 August 1940, 4008015089054, 87 Munro Drive, Reservoir Hills, 28 August 1987. Himal Tugh & Company, P.O. Box 45301, Chatsglen.
- 5392/86—**Jaganath**, Gopichund, 20/11/43, 4311205098054, 148 Bramford Road, Phoenix, 5/8/86; Rajmathi Jaganath, 20/8/43, 4308200116054. Harkoo, Brijlal & Reddy, P.O. Box 48168, Qualbert.
- 3671/87—**Muniamma** (Govender), 17/6/13, 800446628, 5 Kathor Road, Isipingo, 25/6/84; Subramany Kanni, September 1906, 80030108A. Norman Govender Pillay & Co., Third Floor, Bales Building, 436 West Street, Durban.
- 5732/87—**Bensarie**, Sookrania, 16 December 1928, 2812160054058, House 99, Road 721, Montford, Chatsworth, 14 April 1985. A. Christopher & Company, First Floor, Rustomjee Trust Building, 140 Queen Street, Durban.
- 5989/87—**Venter**, Bertha Ellen Louise, 17 May 1910, 246003877W, Sunset Lodge, Doonside, 21 September 1987. Chapman Dyer Incorporated, P.O. Box 81, Durban.
- 5127/87—**Hussionappah**, Kathoon Bee, 8/1/08, 0801010058056, Road 924, House 11, Moorton, Chatsworth, 28/7/87. Ash Haripersad & Partners, P.O. Box 45167, Chatsglen.
- 5689/87—**Baptist**, John, 2/6/43, 800240522A, 70 Commonvale Place, Phoenix, 14/5/87; Salatchiamma Baptist, 800395934A. Helman & Partners, P.O. Box 4091, Durban.
- 5409/87—**Hawes**, Patricia Joan, 8 September 1951, 245012943, 5 Mason Road, Pietermaritzburg, 11 August 1987. Boland Bank Ltd, P.O. Box 1280, Pietermaritzburg.
- 7469/86—**Bhola**, Karamchund Harriram, 22 May 1933, 3305255019051, 17 Anchor Road, Ladysmith, 27 November 1986. A. M. Mortimer & Co., P.O. Box 972, Ladysmith.
- 5901/87—**Lance**, Alice Muriel, 14 May 1904, 0405140013104, 92 St Johns Street, Kokstad, 24 August 1987. Eagle & Barnes, P.O. Box 11, Kokstad.
- 5519/87—**Watson**, Arthur Edward, 2 June 1909, 0906025030006, Tinsley Lodge, Musgrave Road, Durban, 3 August 1987. First Personal Asset Management Co., P.O. Box 2036, Johannesburg.
- 5337/87—**Singer**, Kathleen Meta, 331292459W, Sunnyside Park Home, Private Bag 9081, Pietermaritzburg, 8 July 1987. Van Hulsteyns, P.O. Box 46, Johannesburg.

ORANJE-VRYSTAAT • ORANGE FREE STATE

- 2066/87—**Fourie**, Johanna Martha, 17 Januarie 1942, 4201170052005, Firplek 14, Merriespruit, Virginia, 4 September 1987; Jacobus Hendrik Fourie, Immelman & Immelman, Posbus 195, Virginia.
- 7958/87—**Steyn**, Adriaan Stefanus, 25 Oktober 1916, 1610255009008, Nooitgedacht, Posbus 668, Bothaville, 16 Junie 1987; Gertruida Elizabeth Steyn, gebore Du Plessis, 28 Februarie 1925, 2502280047005. P. I. M. Steyn, Posbus 668, Bothaville.
- 2006/87—**De Beer**, Anna Catharina, gebore Coetzee, 16/10/13, 1310160046001, Uniestraat 32a, Parys, 5/8/87; Abraham Paulus de Beer, 2/12/05, 0512025013008. Bankortrust Bpk., Posbus 2144, Potchefstroom.
- 1874/87—**Van Jaarsveldt**, David Johannes, 1/9/23, 2309015005005, Sanlamparkwoonstelle 803, Bloemfontein, 5/8/87; Elizabeth Catharina van Jaarsveldt, 9/7/25, 2507090014004. Boland Bank Bpk., Posbus 950, Pretoria.
- 1788/87—**De Wet**, Gert Jacobus Benjamin, 9/5/03, 0305095006006, Schilbachstraat 83, Parys, 11/7/87; Elsie Sophia Dorothea De Wet, gebore Viljoen. Vorster & Coetzee, Posbus 5, Parys.
- 2013/87—**Du Plessis**, Maria Elizabeth, gebore Scholtz, 23/8/01, 0108230001001, Hoopstad Huis vir Bejaardes, Hoopstad, 10/9/87. Naudes, Trustfonteingebou, St Andrewstraat 151, Bloemfontein.
- 2036/87—**Chemaly**, Bertie Antonie, 4 Desember 1904, 0412045026007, Kerkstraat 51, Dewetsdorp, 14 September 1987. Carroll, Van de Wall & Joubert, Posbus 10, Dewetsdorp.
- 1781/87—**Cuming-Smith**, Grace Marion, born Jory, 19/5/16, 1605190021001, 13 Schoombe Avenue, Parys, 20/7/87. Vorster & Coetzee, P.O. Box 5, Parys.
- 1296/86—**Ephrem**, Marmar, 4/9/06, 0609040044107, Vegkopstraat 15, Zastron, 15/6/86. Malherbe Saayman & Vermaak, Posbus 44, Zastron.
- 1997/87—**Papefus**, Johan Francois, 21 Julie 1966, 6607215179009, Bassonstraat 7, Bethlehem, 9 September 1987. Breytenbach, Van der Merwe & Botha, Posbus 693, Bethlehem.
- 2047/87—**Scherer**, Reginald Arnold, 29 Desember 1927, 2712295030009, Fitzpatrickstraat 23, Seemeeupark, Welkom, 22/8/87; Stella Frances Scherer, 15 Augustus 1933, 3308150049009. Bankortrust Bpk., Posbus 2413, Bloemfontein.
- 1994/87—**Greyling**, Dina Johanna Petronella, 17/5/36, 3605170005006, Grootvlei, Bethlehem, 29/8/87. Bankortrust Bpk., Posbus 2413, Bloemfontein.
- 1936/87—**Venter**, Johanna Sophia, 16/9/28, 2809160036002, Jamesscottstraat 28, Westdene, Bloemfontein, 30 Augustus 1987; David Gerhardus Jacobus Venter, 3/10/23, 2310035033001. Bankortrust Bpk., Posbus 2413, Bloemfontein.
- 1934/87—**Laurens**, Marthinus Johannes Petrus, 18/12/26, 2612185037009, Allan Robertslaan 11, Odendaalsrus, 27/7/87; Johanna Cornelia Lourens, 30/10/31, 3110300026006. Bankortrust Bpk., Posbus 2413, Bloemfontein.
- 1974/87—**Myburgh**, Sarel Johannes, 9 November 1939, 3911095010000, Nataliërylaan 101, Riebeeckstad, 8 Augustus 1987; Margaretha Myburgh, 1 April 1940, 4004010009007. Bankortrust Bpk., Posbus 2413, Bloemfontein.
- 1995/87—**Hitge**, Nicolaas Jacobus, 17 Desember 1938, 3812170002002, Fouriestraat 31c, Kroonstad, 28 Augustus 1987; Johanna Catharina Hitge, 5 September 1940, 4009050002002. Bankortrust Bpk., Posbus 2413, Bloemfontein.
- 2172/87—**Swanepoel**, Adrian Lombard, 1/4/42, 4204015102001; Dee Side, Queenstown, 21 Junie 1987; Valerie Wray Swanepoel, 11/7/44, 4407110098004. Bankortrust Bpk., Posbus 2413, Bloemfontein.
- 1893/87—**Breytenbach**, Anna Catharina, 25/4/1898, 9804250009004, Sederhof, Veswakte Eenheid, Bethlehem, 21/8/87. Barclays-Nasionale Bank Bpk., Posbus 1714, Bloemfontein.

- 1727/87—**Steyn**, Emmerentia Isabella Catharina, 18/4/05, 0504180033004, Huis Vergeet My Nie, Bultfontein, 8/8/87. Maree & Bernard, Posbus 115, Hoopstad.
 1944/87—**Naude**, Mary, 1906070001000, Presidentstraat 45, Parys, 27 Augustus 1987. Volkskastrust Bpk., Posbus 970, Klerksdorp.
 1978/87—**Potgieter**, Helena Magritha, gebore De Bruin, 11 September 1937, 3709110005009, Louise, Wesselsbron, 10 Augustus 1987; Johan Andries Meyer Potgieter, 26 Mei 1936, 3605265009004. Volkskastrust Bpk., Posbus 323, Bloemfontein.
 1902/87—**Verster**, Louwrens Erasmus, 25 Maart 1908, 0803255010008, Hoogte, Smithfield, 29 Augustus 1987. D. R. de Wet & Potgieter, Posbus 90, Smithfield.
 1875/87—**Kingsley**, Cornelia Maria, 5 Julie 1900, 0007050001002, Stillehawe-ouetehuis, Dewetsdrop, 22 Augustus 1987. Hill, McHardy & Herbst, Posbus 93, Bloemfontein.
 1643/87—**Pryra**, Hendrik Johannes Hertzog, 12 April 1915, 1504125035006, La Rochellestraat 20, Bayswater, Bloemfontein, 10 Julie 1987; Johanna Elizabeth Pryra, gebore Van der Merwe, 11 Junie 1914, 1406110017009. Volkskastrust Bpk., Posbus 323, Bloemfontein.
 1924/87—**Joubert**, Andries Johannes, 17 Oktober 1910, 1010175014008, Skoolstraat 79, Warden, 11 Augustus 1987; Dorothea Maria Joubert, gebore Lessing, 27 Mei 1913, 1305270018007. Volkskastrust Bpk., Posbus 323, Bloemfontein.

Vorm/Form J 187

**LIKWIDASIE- EN DISTRIBUSIEREKENINGS IN BESTORWE BOEDELS
WAT TER INSAE LÊ**

Ingevolge artikel 35 (5) van Wet 66 van 1965, word hierby kennis gegee dat duplikate van die likwidasië- en distribusierekenings (eerste en finale, *tensy anders vermeld*) in die boedels hieronder vermeld, in die kantore van die Meesters en Landdroste soos vermeld en gedurende 'n tydperk van 21 dae (of korter of langer *indien spesiaal vermeld*) vanaf gemelde datums of vanaf datum van publikasie hiervan, as dit later is, ter insae lê van alle persone wat daarby belang het.

Indien binne genoemde tydperk geen besware daarteen by die betrokke Meesters ingedien word nie, gaan die eksekuteurs oor tot die uitbetalings ingevolge gemelde rekenings.

Die inligting word soos volg verstrek: Boedelnommer, familienaam, voornaam(name), persoonsnommer, laaste adres, beskrywing van rekening as dit anders as eerste en finale is; indien oorledene in gemeenskap van goedere getroud was die nagelate eggenoot(note) se name, familienaam en persoonsnommer; tydperk van insae (indien korter of langer as 21 dae), Landdroskantoor.

**LIQUIDATION AND DISTRIBUTION ACCOUNTS IN DECEASED ESTATES
LYING FOR INSPECTION**

In terms of section 35 (5) of Act 66 of 1965, notice is hereby given that copies of the liquidation and distribution accounts (first and final, *unless otherwise stated*) in the estates specified below will be open for the inspection of all persons interested therein for a period of 21 days (or shorter or longer *if specially stated*) from the date specified or from the date of publication hereof, whichever may be the later, and at the offices of the Masters and Magistrates as stated.

Should no objection thereto be lodged with the Masters concerned during the specified period, the executors will proceed to make payments in accordance with the accounts.

The information is given in the following order: Estate number, surname, christian name(s), identity number, last address, description of account other than first and final; if deceased was married in community of property the surviving spouse's names, surname and identity number; period of inspection (if shorter or longer than 21 days), Magistrate's Office.

TRANSVAAL

By die kantoor van die Meester, PRETORIA, en ook van die landdroos van die distrik wanneer dit tussen hakles gemeld word.

By the office of the Master, PRETORIA, and also of the magistrate of the district when stated in parentheses.

- 3508/87—**Otto**, Hendrik Tobias, 1904195008000, Nelmarwoonstelle 9, Greeffstraat 42, Lichtenburg; Gertruida Magaretha Elizabeth Otto, 1707310008007 (Lichtenburg).—T. P. Taylor & Vennote, Lichtenburg.
 12196/87—**Turner**, Annemarie Johanna, gebore Meyer, 4602170059009, Theo Slabbertlaan 885, Booyens, Pretoria.—Bankorptrust, Port Elizabeth.
 7367/85—**Ivanic**, Martin, 5111215059106, Erneststraat 10, Jansenpark, Boksburg; Gertruida Jurina Susanna Ivanic, gebore Van den Berg, 5309010054005 (Boksburg).—Brandmuller, V. d. Berg & Verster, Middelburg.
 6592/87—**Nel**, Izak Andries, 2012195005007, 7 Hagart Street, Brenthurst, Brakpan (Brakpan).—Lovell Miller Dreyer & Kraitzick, Benoni.
 15693/86—**Blackiston**, Christopher Derek Hampton, 4402075141006, Perry's Farm, Hazyview (Nelspruit).—Hefferman Du Toit & Smuts, Nelspruit.
 9161/87—**Richardt**, Johannes Gerhardus, 9907145005002, Kronendal 650, Pretoriusstraat, Pretoria.—Haasbroek & Boezaart, Pretoria.
 14159/84—**Barnes**, Henry George, 1612165021008, Tudhopelaan 37, Randgate, Randfontein (Randfontein).—Naas Ferreira, Pretoria.
 1157/87—**Van der Wat**, Cornelius Johannes, 5710175044006, Rivierstraat 204a, Potchefstroom (Potchefstroom).—Volkskastrust, Klerksdorp.
 6948/87—**Oosthuizen**, Maria Johanna, 1004040035009, Gamtoosstraat 58, Stilfontein (Stilfontein).—Naudes, Bloemfontein.
 2616/60—**Chalnee**, Wanarya, Vereeniging (Bethal).—Gilchrist & Reid, Benoni.
 6971/87—**Van der Burg**, Albertus, 2103245007000, Castenetstraat 36, Tasbet Park, Witbank; Gertruida Maria van der Burg, 2810040035008 (Witbank).—Gerber Ferreira, Witbank.
 8087/87—**Du Plessis**, Cecilia Maria, gebore Mulder, 9612170010006, Tweede Laan 128, Springs (Springs).—Volkskastrust, Bloemfontein.
 2355/86—**Cloete**, Sarel Stephanus, 4307065025002, Lanterweg 122, Wadeville, Germiston (Benoni).—Yssel & Boshoff, Benoni.
 7360/87—**Bekker**, Petrus Barend Christoffel, 1509125002005, Weekstraat 15, Potchefstroom; Elizabeth Maria Wilhelmina Bekker, 2612300001005 (Potchefstroom).—Eerste Persoonlike Batebestuur, Klerksdorp.
 4587/86—**Vermaak**, Beatrix Helena Gertruida, 2901120040008, Thomas Hodgson-ouetehuis, Klerksdorp, Aanvullende (Klerksdorp).—Eerste Persoonlike Batebestuur, Klerksdorp.
 731/87—**Delport**, Johanna Maria, 1406120025000, Christiana (Christiana).—Eerste Persoonlike Batebestuur, Klerksdorp.
 15343/86—**Van den Berg**, Jacobus Cornelius, 2809165030000, Plot 79, Roodepoort, Warmbad (Warmbad).—J. J. Oosthuizen Du Plooy & Vennote, Klerksdorp.
 16743/85—**Rasool**, Goolam, 800002469, Straatsdrift, distrik Marico (Zeerust).—Coulson & Jacobsz, Zeerust.
 12442/72—**Labuschagne**, Heiletjie Maria Margaretha, 361425864W, Kareelaan 9, Rustenburg, Verbeterde Eerste en Finale (Rustenburg).—Wessels & Le Roux, Rustenburg.
 14672/85—**Botha**, Johannes Pieter, 3508275030004, geskei, Olifantspoort, distrik Rustenburg (Rustenburg).—Jac H. Smit Leonard & Breytenbach, Rustenburg.
 7417/87—**Lyons**, Annie Williams, 0308220013004, Hillcrest Geriatric Centre, Johannesburg (Johannesburg)—Malherbe Rigg & Ranwell, Boksburg.

- 7351/86—**Jola**, Carlos Alberto de Brito Figueiroa, 5912125066101, Faraday Boulevard 121, Vanderbijlpark (Vanderbijlpark).—Rood Schoeman, Vanderbijlpark.
- 917/87—**Strydom**, Hester Martha Sophia, 3103170035009, Derricklaan 322, Waterkloof Rif, Pretoria.—Tim du Toit & Kie. Ing., Pretoria.
- 16304/86—**Pearson**, George Charles, 1612115027006, Marigoldweg 7, Primrose, Germiston, Verbeterde Eerste en Finale; Magdalena Susara Pearson, gebore Strydom, 2203270026002 (Germiston).—Schalk Pienaar, Germiston.
- 11612/87—**Mocke**, Jacobus Johannes, 9706185005009, huis Hermon, Pretoria-Noord (Pretoria-Noord).—Boland Bank, Pretoria.
- 11938/86—**Gallie**, Fatima Layla, 370725739, Holding 92, De Deur, District of Vereeniging (Vereeniging).—Shapiro & Partners, Pretoria.
- 3157/87—**Rood**, Aletta Elizabeth, 3009050003001, 4 Charl Cilliersstraat, Vereeniging (Vereeniging).—Rood-Schoeman, Vanderbijlpark.
- 2585/86—**Smith**, Elsie Millicent, 1510050027009, 203 Waverly Court, Burg Street, Boksburg, Second and Final (Boksburg).—S. Bentel Rubens Hirschowitz & Boshoff, Boksburg.
- 1118/87—**Oberholzer**, Susanna Maria Sophia, 1712250043006, Trigaardspoor, Bronkhorstspuit; Frederik Jacobus Oberholzer, 1302045006003 (Bronkhorstspuit).
- 1047/87—**Vermaak**, Trevor, 3704255047007, Sapekoe Middelkop Estates, Tzaneen (Tzaneen).—Mosse & Stewart, Tzaneen.
- 11404/87—**Steinhobel**, Daniel Benjamin, 9609135001005, Klerksdorp-tehuis vir Bejaardes, Rosinstraat 6, Freemanville, Klerksdorp (Klerksdorp).—Volkskastrust, Klerksdorp.
- 6196/85—**Ueckermann**, Ludwig Norman Pieter, 3105295018000, 47 Essenhout Street, Phalaborwa, Supplementary to the First and Final (Phalaborwa).—First Personal Asset Management, Nelspruit.
- 7550/87—**Scheepers**, Johannes Gerhardus, 2202085043008, Clarendonstraat 23, Graskop; Martina Jacoba Scheepers, gebore Van Deventer, 2412100041008 (Graskop).—Eerste Persoonlike Batebestuur, Nelspruit.
- 11279/87—**Labuschagne**, Gerhardus Petrus, 1103215001000, Brinkstraat 12, Coligny; Ivy Sophia Labuschagne, 2610070066000 (Coligny).—Eerste Persoonlike Batebestuur, Klerksdorp.
- 4517/85—**Hippert**, Edward Reuben, 4801015030007, Rhebokfontein, distrik Klerksdorp (Klerksdorp).—Volkskastrust, Klerksdorp.
- 15228/86—**Venter**, Philippus Arnoldus, 2211015015002, Blackwoodstraat 86, Drie Riviere, Vereeniging, Eerste (Vereeniging).—H. B. Coetzer, Boyens & Venter, Vereeniging.
- 16734/86—**Jarvis**, Gladys Maud, 2611160021004, 37 Beechcraft Street, Impalapak, Boksburg; Ronald David Jarvis, 2511025003009, 16 October 1987 (Boksburg).—S. Bentel Rubens Hirschowitz & Boshoff, Boksburg.
- 14881/86—**Viljoen**, Willem Wouter, 4309215043002, Pinelaan 368, Ferndale, Randburg, Eerste; Henrietta Mina Viljoen, 4509300024003 (Randburg).—Ehlers & Vennote Ing., Pretoria.
- 8828/73—**Smit**, Barend Jacobus, 354413886, 12 Anderson Street, Cinderella, Boksburg, Supplementary Liquidation and Distribution; Sarah Johanna Catharina Beatrix Smit, 2610240013007 (Boksburg).—S. Bentel Rubens Hirschowitz & Boshoff, Boksburg.
- 6497/87—**Human**, Frederick Jacobus, 2102035012006, Loeloeraaiwoonstelle 28, Bronkhorstspuit (Bronkhorstspuit).—Volkskastrust, Pretoria.
- 7275/86—**Canova**, Grace, 1611160036003, 157 Retief Avenue, Lyttleton, Verwoerdburg. —Haasbroek & Boezaart, Pretoria.
- 5448/87—**Newberry**, Ann Winifred, 9910040015001, 11 Gesiggie Street, Northmead Extension 4, Benoni (Benoni).—Lovell Miller Dreyer & Kraitzick, Benoni.
- 4428/86—**De Bruyn**, Susara Helena Elizabeth, gebore Coetzee, 6210140071001, Plot 160, Honingnestkrans, Pretoria.—I. J. Coetzee & Kie., Hatfield.
- 9415/87—**Loubser**, Stephanus, 3104105032004, Pendenniswoonstelle 3, Jacob Maréstraat, Sunnyside; Ruth Margareth Loubser, 2402210017006.—MacRobert De Villiers & Hitge Ing., Pretoria.
- 1512/87—**Waks**, Stanley, 4612135045001, 22 Southern Kliprivierberg Road, The Hill Extension 1, Johannesburg (Johannesburg).—Lovell Miller Dreyer & Kraitzick, Benoni.
- 958/87—**Roothman**, Frans Frederick, 2009195001002, Stegmanstraat 84, Krugersdorp-Wes; Albertha Catharina Roothman, 2706210003000 (Krugersdorp).—A. C. Roothman, Kenmare.
- 947/87—**Kruyshaar**, Wilhelmina Frederika, 9006260005002, 29 De Meerpaal, Stellenberg Road, Willowglen, Pretoria.—Metelerkamp & Ritson, Pretoria.
- 13612/85—**Prinsloo**, Alida Johanna, 0905120013008, Karmel 205, Troyestraat, Sunnyside, Pretoria, Gewysigde Eerste en Finale.—Ehlers & Vennote Ing., Pretoria.
- 6677/87—**Borcher**, Amos Samuel Arthur, 0406085001005, Plot 27, Hills and Dales, Randburg; Beatrice Johanna Borcher, born Van der Merwe, 0705280015003 (Randburg).—Syfrets Trust & Eksekuteur (Kaapland), Kimberley.
- 6677/87—**Borcher**, Amos Samuel Arthur, 0406085001005, Plot 27, Hills and Dales, Randburg; Beatrice Johanna Borcher, born Van der Merwe, 0705280015003 (Randburg).—Syfrets Trust & Eksekuteur (Kaapland), Kimberley.
- 6250/87—**Zwiegelaar**, Lourence Sophia, 1808050068001, Tambotiëstraat 38, Middelburg (Middelburg).—Brandmuller, Van den Berg & Verster, Middelburg.
- 6978/87—**Booyens**, Willem Abraham, 2402175043005, Blesbokfontein, Ventersdorp; Susara Johanna Maria Elizabeth Booyens, 2902120030007 (Ventersdorp).—Volkskastrust, Klerksdorp.
- 1163/87—**Brink**, Freda Dorothea Ingman, 2002230015103, 429 Albert Street, Waterkloof, Pretoria.—Findlay & Niemeyer, Pretoria.
- 4325/87—**Botha**, Jan Adriaan, 3105075041008, Karenlaan 16, Lambton Gardens, Germiston; Maria Susanna Elizabeth Botha (Germiston).—Haasbroek & Boezaart, Pretoria.
- 6553/87—**Du Plessis**, Gysbertus Jacobus, 1612165009003, Steenbrasstraat 300, Sinoville, Pretoria; Johanna Susanna du Plessis, gebore Janse van Rensburg, 2005160019003.—Haasbroek & Boezaart, Pretoria.
- 207/87—**Van der Merwe**, Jacobus Erasmus, 2711235021003, Plot 120, Roodepoort Plotte, Posbus 342, Warmbad; Anna Sophia van der Merwe, gebore Venter.—Haasbroek & Boezaart, Pretoria.
- 13507/86—**Scott**, William Martin, 2801125011006, Princessstraat 4, Standerton, Supplémentaire; Susanna Magrieta Scott (Standerton).—Van Heerden, Schoeman De Ville & Boer, Standerton.
- 1495/87—**Scheepers**, Marthinus Johannes, 3109035037007, Ottostraat 72, Krugersdorp-Noord; Martha Maria Scheepers (Krugersdorp).—Hugo & Vermooten, Krugersdorp.
- 4564/87—**Wolfswinkel**, Johannes Cornelus, 3211115029001, De Beerstraat 404, Wonderboom-Suid, Pretoria; Helena Wolfswinkel, 3409110087004.—H. Wolfswinkel, Pretoria.
- 9470/87—**Coles**, Gordon Stanley, 2810235033008, 153 Springbok Street, Wierdapark.—Adams & Adams, Pretoria.
- 2002/87—**Davies**, Mark Edwin, 10 South Gardens, Hoog Street, Middelburg (Middelburg).—Solomon & Nicolson Inc., Pretoria.
- 1162/87—**Abrahall**, Sheila Margaret, 1809100040008, 27 Jolly Street, Bellevue, Johannesburg (Johannesburg).—Solomon & Nicolson Inc., Pretoria.
- 8332/87—**Sinclair**, Alice Maria, 9509210006004, Holy Cross Nursing Home, Claremont, Pretoria.—MacIntosh Cross & Farquharson, Pretoria.
- 13054/87—**Salisbury**, Frederick James, 2311125040104, 41 Tully Street, Turffontein, Johannesburg (Johannesburg).—Bernard L. du Plessis, Alberton.
- 6330/87—**Joubert**, Christiaan Johannes Jacobus, 1711275023001, Dresden, distrik Burgersfort; Elizabeth Johanna Antoinetta Joubert, gebore Burger, 2504050011005 (Lydenburg).—First National Asset Management and Trust Co., Nelspruit.
- 9976/87—**Barnard**, Adam Marthinus, 1604105028003, Combrinkstraat 2, Schweizer-Reneke; Jacoba Aletta Barnard, 2308230022001 (Schweizer-Reneke).—Volkskastrust, Klerksdorp.
- 2509/87—**Palmer**, Harry Albert, 1401225045003, 9 Protea Street, Northmead, Benoni (Benoni).—Edelstein Kahn Connack & Muller, Benoni.
- 16134/86—**Erasmus**, Albert, 1703155017005, Springboklaagte, Ogies, distrik Witbank (Witbank).—Van Heerden Marais & Brummer Ing., Witbank.
- 10500/87—**Jonker**, Francois Hendrik, 9511045003004, Thomas Hodgson-tehuis, Elandsheuwel, Klerksdorp; Susanna Francina Jonker, 0308310004004 (Klerksdorp).—Volkskastrust, Klerksdorp.
- 7447/87—**Du Toit**, Gabriel Jacobus, 2107175015008, Van Riebeeckstraat 157, Potchefstroom; Salome Letitia du Toit, 2305240063009 (Potchefstroom).—Volkskastrust, Klerksdorp.
- 7457/87—**Van Wyk**, Jan, 4810315067007, plaas Buffelsvlei, distrik Ventersdorp (Ventersdorp).—Meyer, Van Sittert & Kropman, Klerksdorp.
- 8965/87—**Spalding**, Albert Alexander Mathew, 4103165018001, Plot 134, Kafferskraal, Klerksdorp; Johannes Diederik Spalding, 3807260028001 (Klerksdorp).—Eerste Persoonlike Batebestuur, Klerksdorp.
- 11202/87—**Nilsen**, Einar Lund, 1211125045007, Wesstraat 7, Coligny (Coligny).—Eerste Persoonlike Batebestuur, Klerksdorp.
- 1360/87—**Lambrechts**, Jacoba Wilhelmina, 2106170009008, Delareyville (Schweizer-Reneke).—Eerste Persoonlike Batebestuur, Klerksdorp.

- 10002/87—**Myburgh**, Anna Maria Sophia Elizabeth, 1110280002003, Springs (Springs).—W. F. Landman, Ermelo.
 6184/86—**Venter**, Pieter Ernst, 5810125004009, Keurboomstraat 25, Kriel; Geraldine Venter, 6309280020008 (Kriel).—Pierre F. Retief, Springs.
 5119/86—**Heinze**, Frances Kathleen, 3909280034009, Brakfontein, Vereeniging (Vereeniging).—Landman & Kie., Bloemfontein.
 4260/86—**Van Rooyen**, Rynier Kapp, 0605075024006, Blinkblaarstraat 41, Van Dykpark, Boksburg; Cornelia Antionette van Rooyen, 3704260030006 (Boksburg).—Malherbe, Rigg & Ranwell, Boksburg.
 14966/86—**Basson**, Johan George Wilhelmus, 3010275085005, Die Sirkel 9, Homelake, Randfontein (Randfontein).—Van Ryneveld Hammes & Wright, Randfontein.
 5479/87/9D—**Barnes**, Elizabeth Susan, 0507190007009, Pretoriusstraat 82, Christiana (Christiana).—Harrison & Marais, Christiana.
 5590/87—**Ingram**, Azalea Joyce, 1501160027005, 10 Glenmead, Manitoza Avenue, Faerie Glen, Pretoria.—A. L. Delaney, Brooklyn.
 11158/87—**Botha**, Nellie, 3903060057009, Soutpansbergweg 310, Rietondale, Pretoria; Hendrik Petrus de Wet Botha, 3803145024000.—Volkskastrust, Pretoria.
 7147/87—**Van Aswegen**, Abram Johannes, 6708205190087, Myrtleweg 20, Valhalla, Pretoria.—Volkskastrust, Pretoria.
 6737/87—**Roos**, Willem Joseph, 300501004, Fiddlestraat 48, Tasbetpark, Witbank.—Volkskastrust, Posbus 383, Pretoria.
 2596/87—**Van der Merwe**, Susara Maria, 3012290039009, Parkstraat, Gewysigde (Witbank).—Volkskastrust, Pretoria.
 8519/87—**De Jager**, Anna Cecilia, 1206130017009, Frangipanistraat 283, La Montagne, Pretoria.—Volkskastrust, Pretoria.
 9732/87—**Minders**, John William, 9810315007008, Van Rensburg-Tehuis, Danville, Pretoria; Magrietha Maria Minders, 0104100012004.—Volkskastrust, Pretoria.
 7942/87—**Kruger**, Louwrence Wilhelm, 22ste Laan 481, Villieria, Pretoria; Fredrika Elizabeth, 1709210002007.—Volkskastrust, Pretoria.
 9276/87—**Booyen**, Hendrik Andries, 1811185016002, Malherbestraat 144, Capital Park.—Volkskastrust, Pretoria.
 4939/87—**Richter**, Hendrina Maria, 1103050024000, Schuurmanstraat 25, Rustenburg; Jacobus Nicolaas Johannes Richter, 0701105009008 (Rustenburg).—Volkskastrust, Pretoria.
 820/87—**Brümmer**, Charles Theodorus, 1909065027006, Wonderboomstraat 502, Pretoria-Noord (Pretoria-Noord).—Volkskastrust, Pretoria.
 6808/87—**Struwig**, Johannes Hermanus, 1803035015003, Loeriestraat 869, Silverton-uitbreiding, Pretoria.—Volkskastrust, Pretoria.
 9182/82—**Barnard**, David Andries, 1810245024006, Ednastraat 310, Lynnwoodpark, Pretoria.—Volkskastrust, Pretoria.
 10565/87—**Van der Westhuizen**, Johannes Jurgens, 1805015006001, Eeufeesstraat 31, Lydenburg; Cornelia Susanna van der Westhuizen, 1704230026008 (Lydenburg).—Volkskastrust, Pretoria.
 11289/87—**Oosthuizen**, Petrus Crisparus, 04080550050, Perseel E57, Marble Hall.—Volkskastrust, Pretoria.
 8575/87—**Taljaard**, Johanna Catharina, 3008200028009.—Volkskastrust, Pretoria.
 2570/87—**Labuschagne**, Christiaan Christoffel, 4810255033001, Swartstraat 4, Lichtenburg (Lichtenburg).—Volkskastrust, Klerksdorp.
 5713/87—**Bredenkamp**, Edna Margaret, 1703170046005, Hortensiastraat 9, Grimbeekpark, Potchefstroom (Potchefstroom).—Volkskastrust, Klerksdorp.
 9110/87—**Botha**, Alida Elizabeth, 0801250001006, p/a Golden Harvest, Kliniek 2, Posbus 4215, Randburg (Johannesburg).—Volkskastrust, Marshalltown.
 9769/87—**Verster**, Willem Karel, 1702165002007, Markonette 14, Japonicastraat, Golfpark, Meyerton; Ella Johanna Dorothea Verster, 2608140019009 (Meyerton).—Volkskastrust, Marshalltown.
 11615/87—**Marx**, Hendrik Christiaan, 2402175005004, Lisemorelaan 110, Crosby; Martha Helena Marx, 7 Maart 1926, 2603070005003 (Johannesburg).—Volkskastrust, Marshalltown.
 10967/87—**Meyer**, Susana Magdalena Johanna, 1012210037002, Noordhoekwoning 3, hoek van Village- en Twaalfde Straat, Randfontein (Randfontein).—Volkskastrust, Marshalltown.
 10743/87—**Nel**, Elizabeth Petronella Christine, 9703110014008, Moria-Tehuis vir Bejaardes, Krugesdorp (Krugesdorp).—Volkskastrust, Marshalltown.
 8173/87—**Van der Merwe**, William Robert, 1304175031009, Diederickstraat 449, Daleside, Meyerton; Susanna Maria van der Merwe, 1809300031005 (Johannesburg).—Volkskastrust, Marshalltown.
 13087/86—**Coetzer**, Casper Johannes David, 1109275009007, Ludlowweg 25, Westdene, Johannesburg (Johannesburg).—Volkskastrust, Marshalltown.
 8051/86—**Law**, Aletta Elizabeth, 1509160008008, Tiendestraat 65, Linden (Johannesburg).—Volkskastrust, Marshalltown.
 6474/87—**Van Aswegen**, Henning Johannes, 2212225017002, Lucaslaan 25, Risiville, Vereeniging (Vereeniging).—Volkskastrust, Marshalltown.
 7170/87—**Hawthorne**, Clarence Frederick, 0909235023001, Raathstraat 58, Horison, Roodepoort (Roodepoort).—Volkskastrust, Marshalltown.
 11131/87—**Rabie**, Pieter Adriaan, 2610105042000, Vincent Bay 3, Bellavistaweg, Turffontein-Wes, Johannesburg (Johannesburg).—Volkskastrust, Marshalltown.
 11926/87—**Snyman**, Jurie Johannes Stefanus, 1112265010001, Dyerstraat 10, Venterspos-Wes (Randfontein).—Volkskastrust, Marshalltown.
 6799/87—**Oosthuizen**, Paul Johannes, 2208105003005, Clydedaleweg 76, Casseldale, Springs (Springs).—Volkskastrust, Marshalltown.
 3576/87—**Meintjes**, Maria Elizabeth Cornelia, 0808180014009, Jan van Riebeeckstraat 182, Pretoria-Noord.—Volkskastrust, Marshalltown.
 2929/87—**Lubbe**, Willem Lourens, 1410185011004, Virtopstraat 8, Gerdview, Germiston; Albertina Christina Petronella Lubbe, 21011300060904.—Volkskastrust, Marshalltown.
 16110/87—**Van den Heever**, Anna Dorothea, 111190016000, Huis Herfsblare, Queenswood, Pretoria.—Volkskastrust, Marshalltown.
 2975/87—**Van Wyk**, Ebenhaezer, 1607215006009, Somersetaan 30, Dalview, Brakpan (Brakpan).—Volkskastrust, Marshalltown.
 5199/87—**Swart**, Petrus Johannes, 2810195016001, Belhambraweg 32, Primrose-Oos, Germiston; Hendrina Johanna Swart, 3304170041001 (Germiston).—Volkskastrust, Marshalltown.
 11263/87—**Graaff**, Lloyd Knighton McIntyre, 1406225010006, Cardingstraat 22, Dalview, Brakpan (Brakpan).—Volkskastrust, Marshalltown.
 11739/87—**Els**, Jacobus Christoffel, 2005135006002, Cowlestraat 28, Rowhill, Springs; Muriel Ruth Els, 2703280004000 (Springs).—Volkskastrust, Marshalltown.
 10900/87—**De Beer**, Hendrika Gertruida Abrama, 0804050021000, Robinsonlaan 82, Discovery; Barend Petrus Stephanus de Beer, 0907135006001 (Roodepoort).—Volkskastrust, Marshalltown.
 8134/87—**Esterhuysen**, Susara Jacoba, 0509280003005, Rusoord Ouethuis, Kantoorstraat, Lydenburg (Lydenburg).—Esterhuysen Botha & Van der Walt.
 3150/85—**Du Plessis**, Willem Hendrik, 5209275002006, Groblersdal, Van Riebeeckstraat; Mev. C. E. du Plessis (Groblersdal).—Truter James de Ridder, Richardsbaai.
 1239/87—**Van Heerdeu**, Barend Willem Jacobus, 1511025012001, p/a Zebediela Landgoed, Zebediela (Potgietersrus).—Metelerkamp & Ritson, Pretoria.
 1169/87—**Crous**, Anna Petronella, 1811150004009, 70 Kok Street, Potchefstroom; Louis Hendrik Crous, 1207305019002 (Potchefstroom).—Stock & Steyn, Roodepoort.
 5710/87—**Bezuidenhout**, Barendina Jacoba, 1886 Wikkelspies, Hermansburg, District of Nelspruit (Nelspruit).—E. J. Braak, Johannesburg.
 11672/85—**Sacks**, Edward, 4802295020007, 94 Ridgeway Drive, Morningside Manor, Sandton (Johannesburg).—Edward Nathan & Friedland Inc., Johannesburg.
 15762/86—**Shapiro**, Hella, 1204070019002, 512 Interlarkn, Eighth Street, Killarney, Johannesburg (Johannesburg).—Edward Nathan & Friedland Inc., Johannesburg.
 4796/83—**Clapper**, Hetie, 0212240012006, 9 Eton Park, Eton Road, Sandhurst, Sandton, Second & Final (Johannesburg).—Edward Nathan & Friedland Inc., Johannesburg.
 16174/86—**Reichenberg**, Alfred Montague, 9708055001001, 506 Roxdale, Second Avenue, Lower Houghton, Johannesburg (Johannesburg).—Bowman Gilfillan Hayman Godfrey Inc., Johannesburg.
 8220/87—**Williams**, Dorothy, 9502260008004, 4 Nottingham Road, Kensington (Johannesburg).—First Personal Asst Management Company, Johannesburg.
 11001/87—**Suttner**, Freda, 3405150045001, 3 Bond Road, Yeoville, Johannesburg (Johannesburg).—First Personal Asst Management Company, Johannesburg.
 9078/87—**Marsh**, Dorothy Francis, 0207160004009, Flemine House, Ranjeslaagte Road, Highlands North (Johannesburg).—First Personal Asst Management Co., Johannesburg.
 8828/87—**Legg**, Heather, 3909280021006, 63 Gordon Avenue, Blairgowrie (Randburg).—First Personal Asst Management Co., Johannesburg.

- 12473/86—**Knill**, Louise, 9402180060008, 904 Crest Hotel, Abel Road, Berea, Johannesburg, Second and Final (Johannesburg).—First Personal Asset Management Co., Johannesburg.
- 9714/87—**Hardy**, Thomas, 1604115021105, 17 Crawford Crescent, Strubenvale, Springs (Boksburg).—First Personal Asset Management Co., Johannesburg.
- 6080/87—**Gerrand**, Helene Volschenk, 2509250030002, 51 Eighth Avenue, Highlands North (Johannesburg).—First Personal Asset Management Co., Johannesburg.
- 2006/87—**Esterhuyzen**, Iris Ivy, 1812010014006, 4 Keet Road, Croydon, Kempton Park (Kempton Park).—First Personal Asset Management Co., Johannesburg.
- 6491/87—**Edgar**, Elizabeth, 0903060028003, Mimosa Hotel, 26 Clarendon Place, Johannesburg (Johannesburg).—First Personal Asset Management Co., Johannesburg.
- 2369/87—**Bosch**, Willem Petrus, 0711265014003, 63 Panther Street, Kensington, Johannesburg (Johannesburg).—First Personal Asset Management Co., Johannesburg.
- 16677/86—**Rautenbach**, Lea Gertruida, 9912050013009, Leeuwfontein, Witbank (Witbank).—Northern Trust Co., Ltd, Marshalltown.
- 3879/86—**Horwitz**, Edel Jacob (Johannesburg).—Johannesburg.
- 533/85—**Singh**, Rabinder (Benoni).—B. Chunalil, Fordsburg.
- 8629/87—**Ellapan**, Madrai, 0906095052054, 60 Gembsbok Street, Extension 2, Lenasia, Johannesburg; Paravathie Pillay, 1306040031056 (Johannesburg).—Bhana, Wadee, Nanabhay & Chibabhai, Johannesburg.
- 10284/80—**Nicolaides**, Chrissoula Christina, Second & Final (Johannesburg).—Johannesburg.
- 507/87—**Lala Dulabh**, Dhani [also known as Dhani Kasan Dulabh (Dhulabh)], 1911060059059, 73 Sunbird Avenue, Extension 1, Lenasia, Johannesburg; Lala Dulabh (also known as Lala Dhulabh), 1412285056053 (Johannesburg).—Bhana, Wadee, Nanabhay & Chibabhai, Lenasia.
- 12944/84—**Susman**, Bertha, 905513213W, Our Parents Home, Spring Road, Gardens, Johannesburg. Supplementary Second and Final (Johannesburg).—Edward Nathan & Friedland Inc., Johannesburg.
- 8975/87—**Vine**, Marjorie Adeline, 0801150025001, 93 Somerset Road, Kensington, Johannesburg (Johannesburg).—E/L M. A. Vine, Johannesburg.
- 1425/87—**Corlett**, Annie Doris, 9511280011005, 310 Park Manor, Corlett Drive, Illovo, Johannesburg (Johannesburg).—R. M. Tucker, Johannesburg.
- 8574/87—**Swart**, Margaretha Johanna, 0505300022009, Kirkbystraat 1271, Queenswood, Pretoria.—Volkskastrust, Pretoria.
- 8589/87—**Wessels**, Jan Hendrik, 0601185005001, 29ste Laan 365, Villieria, Pretoria; Hendrina Gezina Wessels, 0803310025007.—Volkskastrust, Pretoria.
- 3512/84—**Nel**, Gerhardus Ignatius, 0803065008002, Plot 44, Rynoue Landbouhoewes, distrik Pretoria.—Volkskastrust, Pretoria.
- 10867/87—**Smit**, Daniel Marthinus Nell, 0805285002004, Willies Hillstraat 732, Pretoria Tuine; Elsje Petronella Smit, 150503001009.—Volkskastrust, Pretoria.
- 7551/87—**Smal**, Donald Steward, 331285027005, 21ste Laan 569, Rietfontein, Pretoria; Susarah Elizabeth Smal, 3209270067006.—Volkskastrust, Pretoria.
- 2829/85—**Bober**, Heinz Michael Alfred, 4112015049108, Golf Gardens 40, Garstfonteinstraat 56, Marolana.—Volkskastrust, Pretoria.
- 6873/82—**Van Jaarsveld**, Maria Elizabeth, 310205008004, Rissikstraat, Balfour. Gewysigde Eerste en Finale (Balfour).—Haasbroek & Boezaart, Pretoria.
- 3759/85—**Raath**, Alwyn Wessel, 4811075119004, Pretoriusstraat 25, Stilfontein; Rosslyne Coetzee, gebore Moorey, (voorheen Raath), 5112130106105 (Klerksdorp).—Jock du Preez Vorster & Wessels, Pretoria.
- 801/87—**Du Toit**, Cornelia Elizabeth, 1405150013001, Plaas Rietfontein, distrik Bethal (Bethal).—W. R. Badenhorst & De Jager, Pretoria.
- 6128/87—**Vickers**, Cyril George, 3901275037006; Prudence Vickers, 4607180020008 (Springs). M. J. Shneier, Benoni.
- 6454/87—**Smook**, Frederik Johannes, 0601225009005, Kuhnweg 44, Albermarle, Germiston (Germiston).—Du Toit & Du Toit, Germiston.
- 16570/86—**Cox**, Alan Bernard, 6804195015002, The Avenue, 964 Simmer and Jack, Germiston (Germiston).—Du Toit & Du Toit, Germiston.
- 10220/86—**Van den Berg**, Daniel Cornelius, 2704055043009, Frank Bathsraat 3, Middelburg (Middelburg).—Fidelity Bank, Port Elizabeth.
- 5987/87—**Olwagen**, Elsie Johanna Catharina, 24 April 1908, Van Rensburg Monument Tehuis, Delaneystraat 69, Danville, Pretoria.—Dyason Odendaal & Van Eeden, Pretoria.
- 7645/87—**Smith**, Ellen Mary Moncrieth, 0110120002008, 55 Mountainview Drive, Northcliff, Johannesburg.—Messrs Hammond Pole & Dixon, Benoni.
- 1325/85—**Brown**, Adolphine Anna, 0702090010001, 17 Cecile Road, Norwood. Amended Liquidation and Distribution (Johannesburg).—Louis Mendelow, Johannesburg.
- 14066/86—**Bungey**, John Timothy, 2609085074108, 7 First Street, Parkhurst, Johannesburg (Johannesburg).—Fisher Hoffman Stride, Johannesburg.
- 8551/86—**Napier**, William Allan, 0712085032001, 6–1536 Eastern Avenue, North Vancouver, B.C. Canada (Johannesburg).—Fisher Hoffman Stride, Johannesburg.
- 14988/86—**Glesenow**, Walter (Johannesburg).—Gordon Michalson Silver & Frack, Johannesburg.
- 6994/86—**Gray**, Reginald Arthur George (Roodepoort).—Postan & Van der Merwe, Florida.
- 1696/87—**Cowley**, Emma Johanna, 3312567994, 12 27th Street, Malvern, Johannesburg (Johannesburg).—Gerrie van Tonder, Johannesburg.
- 10731/87—**Keeler**, Rodney Edwin, 5303235064006, 75 The Broads, Mulbarton Extension 1, Johannesburg (Johannesburg).—Standardtrust, Marshalltown.
- 9069/87—**Hatch**, Rivona Ellen, 3203120036006, 2 Klein Constantia, Oribi Street, Constantia Kloof (Roodepoort).—Standardtrust, Marshalltown.
- 10468/87—**Chaplin**, David, 1611285032002, 154 St Amant Street, Malvern, Johannesburg (Johannesburg).—Standardtrust, Marshalltown.
- 15682/86—**Tunmer**, Patricia Wallace Moncrieff, 2006120054007, 19 Third Street, Parkhurst, Johannesburg (Johannesburg).—Deloitte Haskins & Sells, Sandton.
- 6652/87—**Mool**, Hester Agnes, 9512110001000, Brixton Old Age Home, 1 Fulham Road, Brixton, Johannesburg (Johannesburg).—E. F. K. Tucker Inc., Johannesburg.
- 5561/85—**Lublinsky**, Joe, 2208155088003, 803 Marble Arch, Goldreich Street, Hillbrow (Johannesburg).—Arthur E. Abrahams & Gross, Cape Town.
- 1252/86—**Wolda**, Jansje Benamina, 1210070025105, 70 Seventeenth Avenue, Edendale (Germiston).—Mrs S. D. van Esch, Johannesburg.
- 5478/86—**Edelson**, Serge Henri Victor, 4401305004000, 95 Milner Avenue, Northcliff, Johannesburg, Supplementary First and Final (Johannesburg).—Norman Sifris & Co., Johannesburg.
- 3900/87—**Melman**, Rosalind, 3410050057007, 58 Primrose Drive, Victory Park, Johannesburg (Johannesburg).—Hillary S. Baitz, Johannesburg.
- 16282/85—**Tshabalala**, Jan, 109750303, 1662 Dlamini Township, Johannesburg (Johannesburg).—Moshidi Kunene & Makume, Germiston.
- 14516/86—**Dodd**, Henry Edward, 0301045039007, 138 Augusta Street, Linmeyer, Johannesburg; Mabel Patricia Dodd, 1207180038002 (Johannesburg).—Cliffe, Dekker & Todd, Johannesburg.
- 2077/87—**Docker**, Winifred, 3004040055005, 24 Stokroos Street, Northmead Extension 4, Benoni; Joseph Richard Docker (Benoni).—First Personal Asset Management, Johannesburg.
- 9931/87—**Magnus**, Lionel Benniworth, 1004015022008, Unit 6, Golden Harvest Village 2, Randburg (Randburg).—First Personal Asset Management, Johannesburg.
- 8559/86—**Quinn**, Vivian Gilbert, 1805315015008, 203 Lakeview, Lake Road, Denlee, Germiston, Amended Supplementary First and Final; Petronella Johanna Alida Quinn (Germiston).—First Personal Asset Management, Johannesburg.

- 3327/87—**Papadakis**, Emanuel John, 0009085009000, 8 Vangelia Court, 51 Ninth Street, Orange Grove (Johannesburg).—First Personal Asset Management, Johannesburg.
- 9756/87—**Rubin**, Rebecca, 0906040032003, Our Parents Home, corner of Spring and High Roads, Gardens, Johannesburg (Johannesburg).—First Personal Asset Management Co., Johannesburg.
- 8561/85—**Janse van Rensburg**, Catharina Maria, 0708240036002, Plot 38, Wheatlands, Second and Final (Randfontein).—First Personal Asset Management, Johannesburg.
- 9806/87—**Panna II**, Leslie, 0908065017000, 316 Camelia Avenue, Lynnwood Glen, Pretoria.—Van Hulsteyns, Johannesburg.
- 2892/87—**De Bruyn**, Philip, 1510045025001, 102 Cindywood, Rivonia Road, Sandown, Sandton (Johannesburg).—Arthur Young & Co., Johannesburg.
- 15717/84—**Michos**, Menelaos Demosthenes, 2409065032006, 57 Milton Road, Lombardy East, Johannesburg (Johannesburg).—Moss-Morris Mendelow Browde, Johannesburg.
- 1367/78—**Packery**, Kananedi, 800019441A, 5 Pigeon Avenue, Extension 1, Lenasia, Amended First and Final Liquidation and Distribution; Jagathambal Packery, born Naidoo, 3008170034052 (Johannesburg).—S. G. M. Mia, Johannesburg.
- 6234/87—**Selebano**, Mothibedi Wellington, 1556486, 8667 Kagiso 2, Krugersdorp; Gabaikangwe Dorothy Selebano (Krugersdorp).—Standardtrust, Marshalltown.
- 8198/87—**Skea**, Gordon Gerald, 1110255020006, Cosmos House, Kensington, Johannesburg (Johannesburg).—Standardtrust, Marshalltown.
- 830/87—**Freygang**, Dora, 2003040020002, 75 Modderfontein Road, President Park, Midrand (Kempton Park).—R. J. Erfmann, Halfway House.
- 12736/86—**Achber**, Louis Hyman, 0306065016009, 42 Restonwold Drive, Saxonwold, Johannesburg (Johannesburg).—Braamfontein.
- 13926/81—**Kadish**, Bennie, 080920511004, 4 Uitkoms Flats, Kleynhans Street, Bethal, Amended (Bethal).—Rapeport Fanaroff & Partners, Johannesburg.
- 16494/86—**Thomas**, Noelly Christel Regine, 9312250007002, Sandown Country Villa, 134 Helen Street, Sandown (Johannesburg).—Deneys Reitz, Marshalltown.
- 7889/87/9D—**Labuschagne**, Evelyn, 0909180023006, 52a Alice Street, Regent's Park, Johannesburg; Jan Harm Labuschagne, 1112145033009 (Johannesburg).—Langstaffe Bird & Co., Johannesburg.
- 8789/86—**Mashinini**, Esther, V/F 1801422 (Johannesburg).—R. N. Bhoolia, Johannesburg.
- 12938/85—**Sothoane**, Elias, 1075659, 1168 Molapo Township, Soweto, Johannesburg; Violet Sothoane, V/F 2238821 (Johannesburg).—R. N. Bhoolia, Johannesburg.
- 8447/85—**Davy**, John Henry, Weskoppies Hospital, Pretoria (Johannesburg).—Werksmans, Johannesburg.
- 15244/86—**Cabrita**, Martrinho, 3005205053107, 90 Fifth Road, Kew, Johannesburg (Johannesburg).—Michael Krawitz, Donenberg & Co., Johannesburg.
- 6969/86—**Botha**, Petrus Jacobus Hendrik, 1804195022003, 410 Bordeaux Court, Hull Street, Florida (Roodepoort).—Van Jaarsveld, Vickers & Rootenberg, Roodepoort.
- 10483/86—**Pearce**, Gladys, 0009110008001, c/o Cosmos House, Flower Foundation Residential Clubs, 4 Nottingham Road, Kensington, Johannesburg (Johannesburg).—Moodie & Robertson, Johannesburg.
- 1012/86—**Hopley**, Magritha, 2207060039004, 81 Eitel Street, Fontainebleau, Randburg (Johannesburg).—W. K. H. Landgrebe, Northcliff.
- 8772/85—**Wright**, Dudley Ralph Monk, 2402055014001, 76 Fourth Street, Albertskroon, Amended; Vivienne Martha Wright (Johannesburg).—Johannesburg.
- 15917/86—**Raymond**, Arthur Bradley, 4902085005000, 7 Golf Street, Linksfeld, Johannesburg (Johannesburg).—Brian Brom, Yeoville.
- 14695/86—**Chapman**, Natalie Irene, 0303270025008, 21 Restanwold Drive, Saxonwold, Johannesburg (Johannesburg).—M. G. N. Goodwin, Johannesburg.
- 11371/86—**Chapman**, Keith Lacy, 0106215006003, 21 Restanwold Drive, Saxonwold, Johannesburg (Johannesburg).—M. G. N. Goodwin, Johannesburg.
- 9357/79—**Myburgh**, Benjamin Jacobus, 2306145044003, Verbeterde (Kempton Park).—Van Rensburg, Schoon & Cronje, Kempton Park.
- 10901/87—**Van den Berg**, Susara Alletta Petronella, 1010070006000, Gedeelte 5 van die plaas Brandvlei, distrik Randfontein; Johannes Petrus Louis van den Berg, 1307135011003 (Randfontein).—Bankorptrust, Johannesburg.
- 1250/87—**Olivier**, Gert Cloete, 4710305060006, Steenveldstraat 8, Freewaypark, Boksburg, Gewysigde (Boksburg).—Bankorptrust, Johannesburg.
- 12345/87—**De Wet**, Jessie, 1107280024003, 1233 Ormonde, Crown Mines (Johannesburg).—Bankorptrust, Johannesburg.
- 10306/87—**Fouché**, Ernst Hendrik, 2108295082001, Bartlettstraat 11, Beyerspark, Boksburg; Maria Magdalena Fouché, 2408190050008 (Boksburg).—Bankorptrust, Kempton Park.
- 14612/82—**Van der Merwe**, Frederick Samuel Peter, 4812235022005, Raysingel 1, Beyerspark Uitbreiding 4, Boksburg, Supplementêre Eerste en Finale; Esther Lorrita van der Merwe, 5105070012002 (Boksburg).—Bankorptrust, Kempton Park.
- 5959/87—**Zandberg**, Martinus David, 2812235020001, Sharonawoonstelle 1, Percyville Crescent, Edleen; Johanna Christina Zandberg, gebore Supra, 2905270013004 (Kempton Park).—Bankorptrust, Kempton Park.
- 3383/87—**Du Randt**, Jan Jonathan, 4311155105007, McCullaghssingel 56, Strubenvale, Springs, Aanvullende; Anna-Marie du Randt, 4604060075004 (Springs).—Bankorptrust, Kempton Park.
- 11146/87—**Williams**, Marthinus Johannes, 4602125051002, Christoffelstraat 19, Van Riebeeck Park, Kempton Park (Kempton Park).—Bankorptrust, Kempton Park.
- 38/87—**Ferreira**, Jacoba Wilhelmina, 5705160061007, St. Blaizestraat 30, Krugersrus, Springs, Eerste (Springs).—Bankorptrust, Kempton Park.
- 12158/87—**Van der Merwe**, Pieter Johannes, 1904145006005, Republiekstraat 58, Baillie Park, Potchefstroom; Anna Jacoba van der Merwe, gebore Du Plessis, 2305140004004 (Potchefstroom).—Bankorptrust, Potchefstroom.
- 11191/87—**De Jongh**, Isabella Maria Catharina, 1412120010000, Stasieweg 30, Potchefstroom (Potchefstroom).—Bankorptrust, Potchefstroom.
- 4397/85—**Barnard**, Johannes Hendrikus, 450125006004, Williamstraat 53, Wilkoppies, Klerksdorp, Tweede Gewysigde Eerste en Finale (Klerksdorp).—Bankorptrust, Potchefstroom.
- 9321/87—**Louw**, Hester Petronella, 3404140039000, 51 Vaalbank, Magaliesburg, Krugersdorp; Stephanus Daniel Louw (Krugersdorp).—Eerste Persoonlike Batebestuurder, Johannesburg.
- 8888/87—**Diedericks**, Bartholomeus Stephanus, 1001305016005, Voortrekkerstraat 25, Balfour; Ellie Cornelia Susanna Diedericks (Balfour).—Eerste Persoonlike Batebestuurder, Johannesburg.
- 1934/87—**Botha**, Hendrik Stephanus Lucas, 6603225092003, Maskewstraat 22, Vanderbijlpark (Vanderbijlpark).—Stabilitas Eksekuteurskamer, Johannesburg.
- 10871/87—**Sousa**, Paul Albertis, 6712175023005, Stegmanstraat 72, Randgate, Randfontein (Randfontein).—Stabilitas Eksekuteurskamer, Johannesburg.
- 3101/87—**Tabbacchiera**, Concetta, 4504160015001, Johannesburgweg 131, Lyndhurst, Johannesburg; Giuliano Giuseppe Tabbacchiera, 4502015064109 (Johannesburg).—Standardtrust, Marshalltown.
- 15312/86—**James**, John Kenneth, 2205055006004, 61 The Trails, Linden Road, Sandown (Randburg).—Lionel J. Waldman, Braamfontein.
- 13355/86—**Cleaver**, Elizabeth Maria, 3107150060101, 2 Eltham Court, corner of Muller and Raymond Streets, Bellevue, Johannesburg, First Liquidation and Distribution (Johannesburg).—Syfrets Trust, Marshalltown.
- 16532/86—**Helliwell**, George David, 1903135030009, 43 Vita Court, 282 Smit Street, Joubert Park, Johannesburg (Johannesburg).—Syfrets Trust, Marshalltown.

- 10525/87—**Odendaal**, Jacobus Johannes, 3310315024009, 11 Lazaar Street, Helikon Park, Randfontein; Gloria Mini Odendaal, 3603120039001 (Randfontein).—Bankorprust, Johannesburg.
- 7136/87—**Wilson**, Marguerite Louise, born Beck, 9709280005007, 68 Ninth Street, Parkhurst, Johannesburg (Johannesburg).—Syfrets Trust, Marshalltown.
- 6070/87—**Dennill**, Christopher James, 2912075023006, 6 Goudenip Street, Birch Acres Extension 3, Kempton Park, First Liquidation and Distribution (Kempton Park).—Syfrets Trust, Marshalltown.
- 7046/87—**Smith**, Mabel, 8709090003003, 48 Barkly Avenue, Discovery, Roodepoort (Roodepoort).—Syfrets Trust, Marshalltown.
- 7585/87—**Spies**, Philippus Jacobus, 6301115143006, 10 Wilgerivier Avenue, Grenelefe, Brakpan (Brakpan).—Bankorprust, Johannesburg.
- 8234/86—**Edgar**, Pauline, 1309240003008, 7 Ridge Heights, 3 Main Street, Townsvlew, Johannesburg (Johannesburg).—Mostert-Bekker, Johannesburg.
- 6061/87—**Bloomberg**, Pearl Valerie, 3508250109005, 23 Begonia Road, Primrose Hill, Germiston; Robert John Bloomberg (Germiston).—Standardtrust, Marshalltown.
- 3022/87—**Oosthuizen**, Hendrik, 1711125049008, Plethaven Caravan Park, Illovo Beach (Durban).—Standardtrust, Marshalltown.
- 11085/87—**Bell**, Joseph Pearson, 1410065025009, 201 Kemsten Avenue, Benoni; Sophie Elizabeth Bell, 1605180021003 (Benoni).—Standardtrust, Marshalltown.
- 7215/87—**Wewege**, John Herman, 1902105021006, Melkhoutlaan 24, Geelhoutpark, Rustenburg; Christina Magrita Wewege, 1910250019006 (Rustenburg).—Bankorprust, Pretoria.
- 8839/87—**Van Niekerk**, Magdalena Jacoba, 2610170058006, Haarhofstraat-oos 1196, Mōregloed; Theodore Herman Matthew van Niekerk, 2905055009003.—Bankorprust, Pretoria.
- 11904/87—**Ras**, Johannes Jacobus, 3905225023008, Wes Acres, Nelspruit (Nelspruit).—Bankorprust, Pretoria.
- 8702/87—**Rademeyer**, Johannes Zacharias, 2803115030004, Mortimerlaan 935, Mayville, Pretoria; Sara Johanna Rademeyer, 3303230029006.—Bankorprust, Pretoria.
- 12293/86—**Coqui**, Henri Harry, 4108105032004, Zorbastraat 198, Murrayfield, Aanvullende.—Bankorprust, Pretoria.
- 772/87—**Erasmus**, Lourens Jacobus, 4009045016000, Haarhofstraat-oos 1248, Mōregloed, Gewysigde; Sagaryd Petronella Erasmus, 5010200064008.—Bankorprust, Pretoria.
- 9794/87—**Fairall**, Ona, 3309200039008, 195 East Avenue, Arcadia; Brian Neil Fairall, 3401015017004.—Bankorprust, Pretoria.
- 6273/87—**Hills**, Magdalena Wilhelmina, 279120082007, Tweede Straat 754, Clewer.—Bankorprust, Pretoria.
- 6382/87—**De Beer**, Maria Elizabeth, 2480110047001, 33ste Laan, Villieria, Pretoria.—Friedland Hart & Vennote, Pretoria.
- 988/85—**Van Hansen**, Stephanus Petrus, 3610035026007, Boekenhoutskloofdrift, Cullinan (Cullinan).—J. F. McMenamin, Pretoria.
- 5481/87—**Bruwer**, Jennifer Elizabeth, 4612120001001, Spitfirestraat 8, Rhodesfield, Kempton Park; Willem Jacobus Bruwer, 3910205002006 (Kempton Park).—Bankorprust, Kempton Park.
- 173/87—**Hefer**, Hendrika Roulofina, 2606050012006, Azalialaan 98, Roodekrans, Roodepoort; Adriaan Johannes Pieter Hefer, 2405305021007 (Roodepoort).—H. M. Nel, Roodepoort.
- 7103/87—**Du Preez**, Jacobus Cornelius, 1107135006007, Vierde Straat 24, Vrededorp, Johannesburg; Maria Elizabeth du Preez, 2108220034002 (Johannesburg).—Jack P. Nel, Elsburg.
- 5602/83—**Clark**, Trevor James Heather, 1405245043005, 305 Elrica, Johan Street, Arcadia, Pretoria, Second Supplementary.—Metelercamp & Riston, Pretoria.
- 10964/85—**Zaaiman**, Dennis Cornelis, 4707205073006, 190 Bellefield Avenue, Mondeor, Johannesburg (Johannesburg).—S. W. Kruger & Young, Johannesburg.
- 5251/86 en 5261/86—**Coetzee**, Adriaan Antonie Jacobus en Aletta Elizabeth, 5508225109005 en 6104090115001, Knightsstraat 12, Witfield, Boksburg (Boksburg).—Standardtrust, Johannesburg.
- 8956/87—**Robinson**, John Lombard, 2308015010007, 18 Aero Road, Valhalla; Julia Robinson.—Savage Jooste & Adams Inc., Pretoria.
- 1419/87—**Barnard**, Johannes Petrus, 0501215019008, Oos-Moot 7, Meyerstraat, Villieria; Johanna Helena Barnard, 1905270013005.—Boland Bank, Pretoria.
- 961/86—**Potgieter**, Margaretha Aletta, 0009210011004, Klipbankweg 51, Ladysmith (Ladysmith).—Bankorprust, Pretoria.
- 14208/86—**Van Rooijen**, Frederik Pieter, 2407165001004, Van Riebeeckweg 131, Nimrod Park, Kempton Park; Rachel Magdalena van Rooijen, 2812120027004 (Kempton Park).—G L Persoonlike Dienste, Kempton Park.
- 4646/87—**Bothma**, Christoffel Alwyn, 4803195079002, Azalealaan 14, Roodekrans, Roodepoort (Roodepoort).—Bankorprust, Johannesburg.
- 3609/87—**Vermaas**, Barend Johannes Jurie, 1012245007004, Tweefontein, Fochville, Eerste (Potchefstroom).—Standardtrust, Johannesburg.
- 12196/87—**Turner**, Annemarie Johanna, gebore Meyer, 4602170059009, Theo Slabbertlaan 885, Booyens, Pretoria.—Bankorprust, Port Elizabeth.
- 11171/87—**Delport**, Gert Francis Lawrence, 4302245106006, Clifton Heights 23, De Kortestraat 92, Braamfontein, Johannesburg; Maudé Marie Delport, 4008170062003 (Johannesburg).—Bankorprust, Johannesburg.
- 4588/87—**Olivier**, Petrus Johannes Marthinus, 4801295020009, Aloestraat 17, Bryanston; Maria Elizabeth Olivier, 4811150107007 (Johannesburg).—Bankorprust, Johannesburg.
- 8533/87—**Van der Merwe**, Petrus Erasmus, 4111095081007, Pennystraat 48, Witpoortjie, Roodepoort; Maria Magdalena van der Merwe, 3807080066009 (Roodepoort).—Bankorprust, Johannesburg.
- 12180/87—**Rademan**, Jacobus Abraham Jacobs, 9905125004003, Plot 16, Withok Estates, Brakpan; Johanna Hendrika Rademan, 04030100030008 (Brakpan).—Bankorprust, Kempton Park.
- Van der Schyff**, Catherine, 5610180168008, Muirlaan 57, Brakpan; David van der Schyff, 5402095058007 (Brakpan).—Bankorprust, Kempton Park.
- Van der Schyff**, David, 5402095058007, Muirlaan 57, Brakpan; Catherine van der Schyff, 5610180168008 (Brakpan).—Bankorprust, Kempton Park.
- Weaver**, Allan Redvers George, 2609115028009, Hoskingstraat 7, Brenthurst, Brakpan; Isobel Harriet Weaver, 3012090075005 (Brakpan).—Bankorprust, Kempton Park.
- 13210/86—**Muller**, David Hermanus Lucas, 2005025019008, Vereeniging (Vereeniging).—Couzyn, Hertzog & Horak Ing., Pretoria.
- 2080/87—**Faithfull**, Vasilija, 2705130013004, Duncanstraat 840, Brooklyn, Pretoria.—Couzyn, Hertzog & Horak Ing., Pretoria.
- 6865/86—**De Waal**, Pieter Malan, 3603125039006, 19de Straat 168, Walvisbaai; Ona de Waal (Walvisbaai).—Couzyn, Hertzog & Horak Ing., Pretoria.
- 1425/86—**Burger**, Anna Cecilia, 1511280005005, Moutonstraat, Hendrina, Aanvullende Likwidasië en Distribusie (Hendrina).—Standardtrust, Pretoria.
- 11018/87—**De Wet**, Johanna Christina Wilhelmina, 9812100005007, Karmel-ouetehuis, Troyestraat, Sunnyside, Pretoria.—Standardtrust, Pretoria.
- 10641/87—**Dredge**, Joseph Alfred, 2109175017000, 410 Garrett Gardens, Dormer Avenue, Queenswood, Pretoria; Eileen Olive Dredge.—Standardtrust, Pretoria.
- 5967/87—**Geyser**, Jeanette Lenie, 1610220036003, Kogelstraat 6, Middelburg (Middelburg).—Standardtrust, Pretoria.
- 3231/87—**Nel**, Adries Marthinus, 1508105008008, Draadstraat 7a, Piet Retief (Piet Retief).—Standardtrust, Pretoria.
- 3241/87—**Nel**, Elizabeth Maria, 1006150009005, Draadstraat 7, Piet Retief (Piet Retief).—Standardtrust, Pretoria.

- 10739/87—**Van der Merwe**, Anna Maria, gebore Du Plessis, Vedalaan 226, Montana, Pretoria; Willem Christiaan de Wet van der Merwe, 0004175010000 (Pretoria-Noord).—Standardtrust, Pretoria.
- 11226/87—**Van Tonder**, Maria Adriana, gebore Jacobs, 0702270001002, Huis Vergenoeg A213, 33ste Laan, Villieria, Pretoria.—Standardtrust, Pretoria.
- 1623/87—**De Beer**, Maria Magdalena, 4809220122006, Ritorwoonstelle 702, Celliersstraat, Sunnyside, Pretoria.—P. J. de Beer, Glenstantia.
- 4893/87—**Bromfield**, Leslie Reginald, 0806195029004, 25 Stanley Road, Irene, Second and Final.—Syfrets Trust, Sunnyside.
- 6791/86—**Van Schalkwyk**, Jacobus Cornelius Johannes, 1205295005007, Verbrande Hoek, distrik Pietersburg, Tweede Gewysigde Finale; Maria Margaretha van Schalkwyk (Pietersburg).—Syfrets Trust, Sunnyside.
- 15693/86—**Blackiston**, Christopher Derek Hampton, 4402075141006, Perry's Farm, Hazyview, District of White River (White River).—Hefferman du Toit & Smuts, Nelspruit.
- 14147/83—**Saunders**, Felicity, Passport Number C910709, 26 Graaf Avenue, Boksburg (Boksburg).—Barry Katz & Partners, Kempton Park.
- 7496/87—**Kleiser**, Werner Helmut, 3905125066107, 504 Damaza Flats, 463 Edmond Street, Arcadia; Giovanna Kleiser.—Bankortrust, Pretoria.
- 6027/87—**Howard**, Lily Elizabeth, 1607090080004, widow, Camelia House, 36 Main Street, Townsvie (Johannesburg).—G. A.E. Goosen, Mondeor.
- 8433/87—**De Jager**, Gerhardus Andries, 0901195029003, Proteastraat 46, Potgietersrus; Elizabeth de Jager, 1004070034005 (Potgietersrus).—Naude Dames & Barnard, Potgietersrus.
- 3598/87—**Swart**, Nicolaas Johannes Jacobus, 3907305080007, 201 Village Gardens, 58 Kotze Street, Sunnyside, Pretoria; Joan Kile Swart.—First National Bank, Arcadia.
- 6094/87—**Makoane**, Juliet Leah, 2602015100142 (Bophuthatswana), 2369 Zone 2, Seapei Street, Ga Rankuwa.—First National Bank, Arcadia.
- 8511/87—**Howard**, Frank James, 1609275001003, 4001 Ceres South Flats, 229 Jacob Mare Street, Pretoria; Cornelia Jeanetta Howard, born Rautenbach.—First National Bank, Arcadia.
- 7619/87—**Holloway**, Henry Mitchell, 0408245022004, 136 Lange Street, New Muckleneuk, Pretoria.—First National Bank, Arcadia.
- 5240/87—**Flanagan**, James Michael, 2208175054003, 86 Sonja Street, Doringkloof.—First National Bank, Arcadia.
- 11095/86—**Jones**, Derek Henry, 3308165110101, 94 Danie Theron Street, Secunda, Supplementary (Secunda).—First National Bank, Arcadia.
- 6864/87—**Röntgen**, Magdalena Jacoba Maria, 9807240003003, Holy Cross Old Age Home, Mostertstraat, Daspoort, Pretoria.—Eerste Nasionale Bank, Arcadia.
- 13178/85—**Maloney**, Cecilia Jacoba, 1204020020001, Rooikoppies 44, Brits, Aanvullende (Brits).—Eerste Nasionale Bank, Arcadia.
- 7405/87—**Kruger**, David Tobias, 2307275022009, Moodiestraat 44, Posbus 8, Eendracht; Maggel Magrietha Kruger (Standerton).—Eerste Nasionale Bank, Arcadia.
- 6691/86—**Bothma**, Maria Magdalena, 1807020014004, Pretoriusstraat 21, Barberton, Tweede en Finale Likwidasië en Distribusie (Barberton).—Eerste Nasionale Bank, Arcadia.
- 4222/87—**Smit**, Theunis Marthinus, 3306145031009, Charl Celliersstraat 74b, Standerton; Aletta Gertruida Catherina Smit (Standerton).—Eerste Nasionale Bank, Arcadia.
- 15109/85—**Brönn**, Hercules Collin, 3106135021006, De Kroon, Brits, Tweede en Finale (Brits).—Eerste Nasionale Bank, Arcadia.
- 3940/86—**Van Loggerenberg**, Johannes Zacharias, 1810095002003, Voortrekkerstraat 134, Coligny, Gewysigde Eerste en Finale Likwidasië en Distribusie; Eva Christina van Loggerenberg (Coligny).—Eerste Nasionale Bank, Arcadia.
- 5426/87—**Elliott**, Elsie Sophia Johanna, 3212240015006, Van der Hoffweg 424, Hermanstad.—Eerste Nasionale Bank, Arcadia.
- 7222/87—**Eksteen**, Anna Fransina Magdalena, 35617692545, Negende Laan 334, Gezina, Pretoria.—First National Bank, Arcadia.

KAAP • CAPE

By die kantoor van die Meester, KAAPSTAD, en ook van die landdros van die distrik wanneer dit tussen hakles gemeld word.

By the office of the Master, CAPE TOWN, and also of the magistrate of the district when stated in parentheses.

- 4088/87—**Crouse**, Frans Josef, 1407015035005, Montagustraat 20, Blanco; Martiena Maria Crouse, 310721002200 (George).—Bankortrust, Port Elizabeth.
- 5463/86—**Putter**, Charl Francois Marais, 0911145034003, Kitchenerstraat 101, Parow; Anna Magdalena Putter, 1906180040005 (Bellville).—Visagie Vos & Swart, Kaapstad.
- 8143/86—**Odendaal**, Willem Gerhardus, 1510165014009, Watergat, distrik Riversdal; Jacoba Hendrika Odendaal, 1403300029001 (Riversdal).—Hofmeyr & Seun, Riversdal.
- 201/87—**Tobin**, Henrietta Amey, 1607020041019, 11 Newmans Avenue, Wheatfield East, Athlone (Wynberg).—L. Kadish & Co., Woodstock.
- 1021/87—**Fourie**, Stephanus Alberus, 1901305017004, Maraisstraat, Franskraal (Hermanus).—Louw & Coutzee, Durbanville.
- 7237/86—**Swartbooi**, Johannes Esmalie, 5906255225019, Galway Court 33, Hanover Park (Wynberg).—Jan S. de Villiers & Seun, Kaapstad.
- 6254/87—**Palm**, Petronella Maria, gebore Joubert, 1307160006001, Huis le Roux, Robertson (Robertson).—Volkskastrust, Bellville.
- 3395/87—**Du Toit**, Daniel Francois Quintus, 1707215002006, Timberonstraat 6, Paarl.—Boland Bank, Paarl.
- 3745/87—**Meyers**, Benjamin Jakobus, 1206105044012, Proteastraat 10, Clanwilliam; Anna Meyers, gebore Koopman, 1401100040012 (Clanwilliam).—Boland Bank, Paarl.
- 4546/87—**Beyers**, Mary Josephine, 454687, Haldaneweg 8, Rondebosch (Wynberg).—De Klerk & Van Gend, Kaapstad.
- 4137/87—**Bonzet**, Mathys Louis, 0209175006003, Kruisvalleistraat 2, Tulbagh (Tulbagh).—Boland Bank, Tulbagh.
- 4322/87—**Swart**, Jacob Izak, 1707275002003, Daneelstraat 22, Stanford; Alida Catherina Elizabeth Swart (Hermanus).—De Klerk & Van Gend, Bellville.
- 6406/86/6C—**Schüter**, Henrietta, 0601310036004, 93 Fourth Avenue, Rondebosch East, Cape Town (Wynberg).—K. G. Druker, Cape Town.
- 2848/87—**Fritz**, Mary Cornelia, 2202100047018, 2 Jool Street, Bellville; Henry Fritz (Bellville).—A. Wagner de Villiers, Cape Town.
- 4569/87—**Bosman**, Catherine Christina Engela, gebore Putter, 1902150040000, Ryk Tulbaghstraat 31, Da Nova, Mosselbaai; Johannes Christian Frederick Bosman, 1502055001006 (Mosselbaai).—Boland Bank, George.
- 4576/87—**Le Grange**, Diederika (Diderika) Johanna Hattingh, 1404210040005, Graaff-Reinetlaan 7, Hartenbos (Mosselbaai).—Boland Bank, George.
- 5184/87—**Verster**, William, 1711165039000, Hospitaalstraat 63, Paarl (Paarl).—Boland Bank, Paarl.
- 3225/87/5D—**Blom**, Petrus Arnoldus, 0504265013004, Sylvanstraat 29, Steynsrust, Somerset-Wes; Monica Astria Blom, gebore Barrett (Somerset-Wes).—Volkskastrust, Bellville.
- 3886/87—**Steenkamp**, Willem Johannes, 1304255010006, Williston Hotel, Williston (Fraserburg).—Volkskastrust, Bellville.
- 3511/86—**Crowley**, Paulina, 042967583, Pantherrylaan 4, Pacaltsdorp (George).—Raubenheimers, George.
- 1552/86—**Hough**, Anna Susanna, 2701030004007, Belamoerwoonstelle 4, Koebergweg, Milnerton.—De Klerk & Van Gend, Kaapstad.
- 1153/83—**Taute**, Pieter Martinus Johannes, 2805145967005, Ericastraat 42, Heatherlands, George (George).—Millers Ingelyf, George.
- 2213/87—**Jordaan**, Margaretha Wilhelmina, 9409010001000, Johenco Tehuis, Sutherland (Sutherland).—Louw & Frick, Sutherland.
- 7565/86—**Botha**, Tielman, 2505135004006, Oranjestraat 16, Parys (Parys).—Marais Müller, Bellville.
- 5079/86—**Lötter**, Andries Petrus, 3010295031005, Ongegund, Simondium; Cornelia Christina Lötter, gebore Crous, 2604300061006 (Paarl).—Boland Bank, Paarl.
- 3792/87—**Dorfman**, Alexander Abraham, 0602235002006, 54 Fairview Avenue, Woodstock.—Le Roux & Van der Westhuysen, Vanrhynsdorp.
- 3221/72—**Du Preez**, Carolina Wilhelmina Elizabeth, 24121898, Stiklandhospitaal, Bellville, Supplementêre (Bellville).—Ernst Strauss & Haasbroek, Kaapstad.

- 6080/86—**Ferreira**, Susanna Elizabeth, 3301100062008, Prinses Alicelaan 8, Ysterplaat.—Ernst Strauss & Haasbroek, Kaapstad.
- 4903/83—**Johannes**, Henry (Isaac of Isaac), 270906249, Hesterstraat 104, Valhalla Park; Margaret Johannes (Goodwood).—Booyesen & Horn, Parow.
- 2518/87—**Loubser**, Alida Jacoba, 0709240027009, Uniestraat 77, Strand (Strand).—Bisset, Boehmke & McBlain, Cape Town.
- 2519/87—**Loubser**, Edward William, 0001045006002, Uniestraat 77, Strand; Alida Jacoba Loubser, 0709240027009 (Strand).—Bisset, Boehmke & McBlain, Kaapstad.
- 5144/86—**Campbell**, Terence Alexander, 4906115018008, 2 Janssen Street, Bothasig; Louissa Ann Campbell, 5306240145009 (Goodwood).—J. Olivier & Fourie, Parow.
- 2496/87—**Groenewald**, Coenraad Johannes, 1509285032008, Bezuidenhoutstraat 5, Stanford (Hermanus).—Boland Bank, Caledon.
- 4575/87—**Gillomee**, Johannes Gerhardus, 2108105015001, Golfstraat 11, Bredasdorp (Bredasdorp).—Boland Bank, Bredasdorp.
- 4177/87—**Fielies**, Johannes, 1310265047011, Barrystraat 123, Riversdal; Johanna Karlina (Riversdal).—Hofmeyr & Seun, Riversdal.
- 3962/87—**De Lange**, Johannes Abram, 0302055001002, Tehuis Jan Lange, Riversdal (Riversdal).—Volkskastrust, Bellville.
- 3424/87/4D—**Schwarz**, Berta Pauline, 901520035W, Duinfontein, Aurora (Vredenburg).—Volkskastrust, Bellville.
- 3970/87—**Steyn**, Frederick Wilhelm, 9805265005002, Jeffreystraat 15, Ceres (Ceres).—Volkskastrust, Bellville.
- 2122/87—**Nel**, Anton, 1405235038007, Cummingsstraat 75, Wellington (Wellington).—Volkskastrust, Bellville.
- 3208/87—**Rust**, Dirk Jacobus Adriaan, 2101065015004, Volsteedstraat 68, Strand (Strand).—Volkskastrust, Bellville.
- 1438/87—**Hollingshead**, Eva Mary, 1012050014004, 101 Rapallo, Beach Road, Sea Point.—Francis Thompson & Aspden, Cape Town.
- 3489/85—**Lashmar**, Christina, deceased, 19 Doreen Road, Grassy Park (Wynberg).—Wilkinson Joshua & Gihwala, Athlone.
- 2195/87—**Koransky**, Elizabeth, 1009260014105, 502 Albermarle, Mouille Point.—Penkin Zeller & Karro, Cape Town.
- 1962/85—**Phillips**, Anthony Peter, 9/3/32, Radio Station, Klipheuvel (Malmesbury).—M. S. Frank & Frank, Cape Town.
- 8785/86—**Bailey**, Ronald John, 3712155126105, Leelilo, Pear Lane, Constantia (Wynberg).—Lansdown Ellis & Company, Observatory.
- 1697/86—**Mphatse**, Lena, 6 Ivanhoe Street, Kraaifontein (Bellville).—W. A. Groenewald & Co., Athlone.
- 6043/86—**Fraser**, Henry Weston, 2604025053015, 45 14th Avenue, Elsie's River; Charlotte Maria Fraser (Goodwood).—W. A. Groenewald & Co., Athlone.
- 7/87—**Land**, George Ian, 0902015014001, 84 Visagie Street, Parowvallei (Bellville).—The Board of Executors, Johannesburg.
- 8389/86—**Fisher**, Jeremy Alister, 5907185168011, 17 Vredenburg Street, Westridge, Mitchells Plain (Wynberg).—Abe Swersky & Associates, Cape Town.
- 7366/86—**Johnson**, Hazel, 6 Glen Close, Grassy Park.—S. Radowsky Executor, Roggebaai.
- 1606/84—**Klein**, Elizabeth Dorothy (Lizzie), 3012310076015, 16 Pinedene Street, Ravensmead (Goodwood).—Van der Ross & Motala, Cape Town.
- 4657/85—**Allie**, Ebrahim Gaffoor, 850048275A, 511 Halt Road, Elsie's River (Goodwood).—S. M. Kessler Lazarus & Borok, Goodwood.
- 417/87—**Higgins**, Andy Milward, 5208095152082, 33 Daphne Crescent, Woodlands, Mitchells Plain; Lilian Levina Higgins (Wynberg).—Dommissie & Butler, Rondebosch.
- 1730/83—**Allie**, Akbar (Chiktay), 800033125A, Sussex Road, Wynberg (Wynberg).—Heyns & Partners Inc., Goodwood.
- 8478/86—**Bouah**, Peter Martin, 4603135149018, Turfhall Cheshire Home, Turfall Road, Lansdowne (Wynberg).—Syfret Godlonton-Fuller Moore Inc., Cape Town.
- 2198/87—**Moore**, Stanley Albert Walter, 2609185015001, 67 Stanley Road, Claremont (Wynberg).—Esau Shapiro, Isaacson & Burman, Claremont.
- 3970/67—**Ward**, Sarah Maria, 0227835927W, 76 Main Street, Newlands, Amended (Wynberg).—Thompson Smithers & Bradley Inc., Wynberg.
- 3613/87—**Martin**, Florence Norah Louise, 000118000008, Muizenberg Place, 6 Melrose Road, Muizenberg (Simon's Town).—Guthrie & Rushton, Fish Hoek.
- 7301/86—**Goodman**, Ida Gertie, 9812260018006, Highlands House, 234 Upper Buitenkant Street, Cape Town.—G. Goodman, Cape Town.
- 4043/86—**Grunder**, John Vivian, 2602185009009, 11 Constantia Street, Panorama, Parow; Grunder Florenda, 3501030009009 (Parow).—Baker Musikanth, Cape Town.
- 6013/87—**Gunter**, Jeremias Jacobus, 1105185024003, Kondoahof 4, Parow; Jacoba Frederika Gunter, 2301090016007 (Bellville).—Volkskastrust, Bellville.
- 2920/87/2D—**Edem**, Elizabeth Magdalene, gebore Langeveldt, 2401150054011, Cooperstraat 63, Swellendam; Simon Johannes Edem, 1809145064013 (Swellendam).—Volkskastrust, Bellville.
- 3688/87—**Barnardt**, Maria Magdalena, 0607040022008, Philipstraat 12, Ceres (Ceres).—Volkskastrust, Bellville.
- 844/87—**Ollewagen**, Aleita Johanna Barendina, gebore Perold, Huis Jan Swart, Lourensrivierweg, Strand (Strand).—Boland Bank, Strand.
- 2002/87—**Venter**, Johannes Hendrik, 2803295040005, Briardenestraat 28, Parowvallei; Johanna Dorothea Venter, 2711030030001 (Bellville).—Van Niekerk, Groenewoud & Van Zyl, Bellville.
- 806/87—**Legge**, Grace Christian, born Sinclair, 9811270006001, 56 Long Street, Mossel Bay (Mossel Bay).—Pauw Rauch Gertenbach & Moolman, Mossel Bay.
- 713/87—**Kellerman**, Stephanus Johannes, 4101075246008, Algostraat 50, Strand; Merline Emelda Kellerman, gebore Burgoyne, 4906240555080 (Strand).—Boland Bank, Strand.
- 8803/86—**Ismail**, Ebrahim, 1603255038028, 1 Meerhof Street, Huguenot, Paarl (Paarl).—S. G. Hoffman & Van Tonder, Paarl.
- 148/87—**Duncan**, Frances Elizabeth, 096736026C, Goederust, La Motte, Franschoek (Paarl).—S. G. Hoffman & Van Tonder, Paarl.
- 2459/84/6D—**Ehlers**, Catharina Antoinetta, gebore Nortier, 0510260008006, Merrimanstraat 81, George, Gewysigde Eerste en Finale (George).—Volkskastrust, Bellville.
- 5208/87—**Carstens**, Cornelia Magdalena, 9803180001008, weduwee, p/a Sassar Aftree-oord, Parow (Bellville).—Marais Müller, Bellville.
- 1015/85/5B—**Van Zyl**, Johannes, 2412135019003, Kwaaiputs, Williston, Gewysigde Eerste en Finale (Williston).—G. B. Kempfen & De Wet Nel, Camarvon.
- 3892/86—**Boshoff**, Mary Gertrude, Nuwe Uitbreiding, Barrydale; Jan Johannes Jacobus Boshoff, 4103025044015 (Swellendam).—A. S. Powell & Kelly, Swellendam.
- 5894/87—**Williamson**, Claude Pyper, 1108275009009, 85 Formosa Garden Village, Plettenberg Bay (Knysna).—Standardtrust, George.
- 5610/87—**Alberts**, Cornelius Theodorus, 3503265069005, 21st Lane 70, Mossel Bay; Maria Magdalena Alberts, 3410040061002 (Mossel Bay).—Standardtrust, George.
- 9006/86—**Van der Vyver**, Mary Elizabeth, 9602030003002, Huis Izak van Tonder, Ladismith (Ladismith).—Barry & Mouton, Calitzdorp.
- 4260/87—**Pereira**, Cornelia Jacoba, 1510050028007, Sand-en-See 204, Pophamweg, Bloubergstrand; Antonio Francisco Pereira.—Marais Müller, Bellville.
- 3658/87—**Metcalfe**, Maria Johanna, 921017003004, Lettie Theron Home, Hermanus (Hermanus).—Guthrie & Theron, Hermanus.
- 913/87—**Grobler**, Willem Petrus, 2905075009009, Dizalaan 6, Somerset-Wes; Petronella Grobler, 3307290008008 (Somerset-Wes).—Volkskastrust, Bellville.
- 7833/86—**Botes**, Antonie Johannes Jurgens, 2406175011003, Schoppelmaaykraal, Merweville; Bertha Lilian Ernestine Botes, 2603050005007 (Beaufort-Wes).—Standardtrust, Kaapstad.
- 4490/87—**Brierley**, Evelyn, born Foxcroft, 0708050035003, widow, Stadium Residence, Main Road, Green Point.—Silberbauers, Cape Town.
- 1849/87—**Van Wyk**, Willem Wynand, 1510285049000, 3 Calamaran Close, Sun Valley (Simon's Town).—Guthrie & Rushton, Fish Hoek.
- 5089/87—**Osbourne**, Doreen Isabel, 1811010037009, 46 Garfield Road, Claremont; Eric Charles Osbourne, 2007275038001 (Wynberg).—Esau Shapiro, Isaacson & Burman, Claremont.

- 3853/83—**Baker**, Ada Marie, 022865963, 121 Seventh Avenue, Kensington, First.—Carse, Müller & Visser, Cape Town.
 3151/87—**Langeveldt**, Mary Elizabeth, 30 Ross Road, Wynberg (Wynberg).—Herold Gie Inc., Cape Town.
 1463/86—**Solomon**, Toyer, 022638350, 45 Kent Road, Wynberg (Wynberg).—M. S. Frank & Frank, Cape Town.
 6331/86—**Greyling**, Florence Joyce, 2311150032000, 17 Oak Farm Crescent, Constantia, First (Wynberg).—Arthur E. Abrahams & Gross, Cape Town.
 2269/87—**Jacobson**, Hyman, 1709125057005, A32 Glenvalley, Jorgens Avenue, Kenilworth (Wynberg).—Bass Gordon Willis, Cape Town.
 8422/85—**Crowle**, Charles Alexander, 1003105062015, 6 Le Grange Road, Grassy Park (Wynberg).—Wagner & Associates, Northpine.
 4175/87—**Byrnes**, Shirley Carey, 35101020049007, 46 Nuttall Road, Observatory.—Sonnenberg Hoffman & Galombik, Cape Town.
 1981/87—**Corcoran**, Maria Assunta, formerly Hart, born Carrega, 10 Via Buffa, Ovada, Piemonte, Italy.—Sonnenberg Hoffmann & Galombik, Cape Town.
 2474/87—**Abrahams**, Daniel Stephanus Johannes, 5 Ninth Avenue, Elsie's River; Elizabeth Abrahams (Goodwood).—Balsillie Watermeyer & Cawood, Cape Town.
 2281/87—**Clough**, Mildred Anne, born Ashworth, 1610190025002, 528 Seven Oaks, Main Street, Newlands (Wynberg).—Syfrets Trust, Cape Town.
 4202/86—**Basson**, Michael Nicolaas Smuts, 2203065017004, Schuilplaats, Paradyskloof, Stellenbosch; Leonie Wilhelmina Basson, 3101010050006 (Stellenbosch).—Kuit & Kuit, Lydenburg.
 2339/87—**Skaife**, John Croft, 2710045030006, The Long Barn, Outuin, Skaife Street, Hout Bay (Wynberg).—The Board of Executors, Cape Town.
 7883/85—**Behschnitt**, Gertrud, born Pruenke, divorcée, Theaterplatz 1, Bon Bad Godesberg, West Germany, Supplementary.—The Board of Executors, Cape Town.
 892/87—**Crowley**, John Henry, 0508125030009, Cecil House, 28 Rouwkoop Road, Rondebosch, Amended First and Final; Pearl Agnes Crowley (Wynberg).—C. & A. Friedlander Inc., Cape Town.
 4313/87—**Murphy**, John Wherry, 2104145062004, 48 Rhodes Street, Goodwood (Goodwood).—Jan S. de Villiers & Seun, Kaapstad.
 1869/87—**Stevens**, Dinah Margarita, 0207310004008, 32 Aspeling Street, George (George).—Jan S. de Villiers & Son, Cape Town.
 7578/86—**Lotfers**, Irene Margaret, 115269948K, 87 Sullivan Street, Retreat, Cape Town; Frederick Razar Lotfers, 115269947K (Wynberg).—Watkin & Kaplan, Cape Town.
 333/87—**Fredericks**, Philippina Johanna, 0708070032014, 39 Park Road, Walmer Estate, Woodstock.—M. S. Frank & Frank, Cape Town.
 1624/82—**Lotter**, Lawrence James, 4401015075019, 15 Queens Road, Woodstock, Second Amended; Erica Maria Lotter.—B. P. H. Curran, Claremont.
 2536/87—**Soule**, Vera Ethel, 9212020005007, 32 Dixon Road, Mowbray (Wynberg).—Syfrets Trust, Cape Town.
 3137/87—**Hyder**, Gladys Irene, born Baker, 226071, 2 Russell Lodge, Christ Church, Main Road, Constantia (Wynberg).—Syfrets Trust, Cape Town.
 2624/87—**Davie**, Maurice Mervyn, 0802155039109, 1 Belmain Court, Bellevue Terrace, Kenilworth (Wynberg).—Syfrets Trust, Cape Town.
 5586/87—**Petticrew**, Eric Alexander, 1412305018000, 174 Market Street, Parow Valley (Bellville).—Syfrets Trust, Cape Town.
 3671/87—**Spijkers**, Johannes, 1401155005001, Zerilda Steyn Home, Pinelands (Goodwood and Wynberg).—Syfrets Trust, Cape Town.
 3287/87—**Böhme**, Petronella Johanna Maria, gebore Van Haaren, 2207110055109, Leerdamstraat 19, Avondale, Parow (Bellville).—Syfrets Trust, Kaapstad.
 7752/67—**Mills**, Gordon Cooke, London, United Kingdom.—Bloomberg & Co., Cape Town.
 1805/87—**Dreyden**, Christian William, 57 Parkdene Street, Ravensmead; Sarah Mildred Dreyden, born Alexander (Bellville).—Windell & Conrardie, Parow.
 4728/85—**Commins**, William Edward, Moonraker, Amber Way, Noordhoek (Simon's Town).—Pincuz Matz-Marquard Hugo-Hamman, Claremont.
 4479/86—**Trickett**, Ruth, 3110150010001, 13 Hof Street, Gardens, Cape Town.—Arderne Lifson & Hanekom, Port Elizabeth.
 4642/87—**Cartwright**, Peter, 2711135055101, 32 Franshoek Road, Durbanville Hills (Bellville and Randburg).—Barclays National Bank, Cape Town.
 5423/87—**Thorpe**, May, born Small, 2705130066006, 3 Leonard Street, Southfield; Denzil Edmund Thorpe, 2607195066006 (Wynberg).—Barclays National Bank, Cape Town.
 4855/87—**Bestbier**, Barend Liebenberg, 1501315015004, Alettahof 1, Van der Spuystraat, Strand (Strand).—Eerste Nasionale Bank, Kaapstad.
 1153/87—**Baard**, Willem Johannes, 1806075023001, Brewerstraat, Klawer; Hester Christina Baard, 2202040070005 (Van Rhynsdorp).—Eerste Nasionale Bank, Kaapstad.
 3363/87—**Wright**, Benjamin Matthys, 1211065032007, Hoofstraat 88, Kleinmond; Mary Jane Wright, gebore Langenhoven, 1412160030009 (Caledon).—Barclays-Nasionale Bank, Kaapstad.
 3057/87—**Du Preez**, Jan Lourens, 2305285037009, Maroelastraat 33, Mosselbaai (Mosselbaai).—Barclays-Nasionale Bank, Kaapstad.
 1165/87—**Merrons**, Mer, Passport No. C631699D, 73 Byron Street, Windsor Park, Kraaifontein (Bellville).—Barclays National Bank, Cape Town.
 5139/87—**Schluter**, John, 3009145089007, 37 St Johns Road, Sea Point; Joyce Elsie Schluter, 2804130005308.—Barclays National Bank, Cape Town.
 2134/86—**Rhoda**, Faried, 4811215108024, Breweryweg 22, Strand, Gewysigde (Strand).—Murray Smith & Swanepoel, Strand.
 926/87—**Van der Westhuizen**, Izak Petrus, 3512095019007, 33 Retief Street, Worcester (Worcester).—Robertson, Botha, Kotze & Badenhorst, Worcester.
 2465/87—**Van den Berg**, Cornelius, 2606275015008, Bowerstraat 36, Ysterplaat; Susanna Magdalena van den Berg, 4407020052000.—Volkskas-trust Bellville.
 3614/87—**Van der Merwe**, Rudolph, 1204245010001, Huis Marie Louw, Reitzstraat 4, Somerset-Wes (Somerset-Wes).—Volkskas-trust, Bellville.
 8385/85—**Abramsohn**, Jacob Marcus, 1704035051008, 16 Prideaux Road, Rondebosch (Wynberg).—Banard Katzeff & Co., Salt River.
 1868/87—**Rosenberg**, Bessie, born Fromm, 1810150037084, Crieve, Yarmouth Road, Muizenberg (Simon's Town).—Salt River.
 3588/87—**Ellis**, Arthur Anthony, 5823275062000, Littlewoodweg 5, Marinda, Kuilsrivier; Cheryl Belinda Ellis, gebore Jordan, 6203320150004 (Kuilsrivier).—Bankorprust, Bellville.
 5644/87—**Flick**, Ada Beatrice, 9912120020000, Ashteadweg 18, Groenpunt.—Bankorprust, Bellville.
 2175/87—**Galant**, Georgina, 0311230026016, Fouriestraat 58, Bellville-Suid (Bellville).—Bankorprust, Bellville.
 5709/87—**Geldenhuis**, Johannes Josias, 2403265043004, Akasialaan 9, Edenpark, Brackenfell; Johanna Hendrika Geldenhuis, gebore Koen, 2311010042009 (Bellville).—Bankorprust, Bellville.
 3915/87—**Groenewald**, Isaac Andrew, 4205095034014, Steenkampstraat 5, Sarepta, Kuilsrivier; Johanna Jacqueline Groenewald, gebore Sampson, 4606090058017 (Kuilsrivier).—Bankorprust, Bellville.
 5082/87—**Hamman**, Elizabeth Marais, 1510200045000, Kerkstraat 76, Wellington (Wellington).—Bankorprust, Bellville.
 5875/87—**De Jongh**, Andries Nicolaas Everhardus, 1712105022007, Riebeeckstraat 196, Goodwood (Goodwood).—Bankorprust, Bellville.
 5723/87—**Le Roux**, Cecilia Petronella, 1309070019009, Koninginstraat, Ladysmith (Ladysmith).—Bankorprust, Bellville.
 8839/85—**Mathys**, Paul, S.A.K.K., Eerste-rivier (Kuilsrivier).—Bankorprust, Bellville.
 4912/87—**Mostert**, Jan Johannes Barend, 4904195089007, Herculessingel 43, Solheim, De Aar; Mabel Margaret (Margarett) Elizabeth Mostert, 5310290116001 (Goodwood en De Aar).—Bankorprust, Bellville.

- 5242/87—**Serafin**, Elizabeth Jessie, gebore Manefeldt, 1804170059004, Thomas Bowlerlaan 6, Edgemead (Goodwood).—Bankorptrust, Bellville.
 6118/87—**Shelley**, Patricia, 2601270025003, 4 Wolworths Flats, Main Road, Sea Point.—Bankorptrust, Bellville.
 8758/86—**Sibrower**, Henri, 9701135009003, Longmargohof 201, Coronationweg, Maitland, Supplementêre tot die Eerste en Finale Likwidasië en Distribusie.—Bankorptrust, Bellville.
 5701/87—**Smit**, Anna Jacoba Gysbertha, gebore Carstens, 0807070037005, Visagiestraat 137, Tiervlei; Nicolaas Mattheus Smit, 1808165003000 (Bellville).—Bankorptrust, Bellville.
 6346/87—**Swart**, Hermanus Jacobus, 0701175029001, Tierhof 7, Tygervalleistraat, Parow (Bellville).—Bankorptrust, Bellville.
 6414/87—**Abels**, Fredirek, 2405105055015, Eikestraat 31, Cloetesville, Stellenbosch; Hester Abels, 2404040073019 (Stellenbosch).—Bankorptrust, Bellville.
 5050/87—**Borland**, Gordon Leslie, 1912155080000, Joubertweg 19, Groenpunt, Kaapstad; Verna Violet Borland, gebore Prosser.—Bankorptrust, Bellville.
 5866/87—**Booker**, Elizabeth Maria, gebore Barendse, 0206240016009, Irenehof 7, Strandweg, Strand (Strand).—Bankorptrust, Bellville.
 4797/87—**Breytenbach**, Jacobus Bruwer, 4508125010007, Wakkerstroom, Robertson (Robertson).—Bankorptrust, Bellville.
 5556/87—**Cauvin**, Engela Hester Cecilia, born De Langer, 0201130001005, Zerilda Steyn Memorial, Pinelands, 30 dae.—Bankorptrust, Bellville.
 4984/87—**Coetzee**, Johannes Stephanus, 1009055037006, Wynnestraat 25, Parow; Marie Petronella Cornelia Margaretha Coetzee, gebore Langenhoven, 1809040053004 (Bellville).—Bankorptrust, Bellville.
 4860/87—**Cordier**, Anthonie Louis de Wet, 2309165021000, Jessiestraat 2, Chrismar, Bellville (Bellville).—Bankorptrust, Bellville.
 6057/87—**Swartz**, Henrietta Jaenna, gebore Lesch, 5105300142017, Mendelsonstraat 13, Mandalay; Ronald Swartz, 5306175115019 (Wynberg).—Bankorptrust, Bellville.
 2083/87—**Stembridge**, Maureen Hilary, 4210110072007, 20 Andalusia Avenue, Somerset West; Allen Frederick Stembridge, 4010225073001 (Somerset West).—Theron & Co., Plettenberg Bay.
 2312/87—**Conradie**, Gert, 1211015024005, Herfsvreugde, Bonnievale (Bonnievale).—Van Niekerk & Linde, Bonnievale.
 21/87—**Du Toit**, Anna Maria, 1306240013003, Stillerwee 15, Dennisstraat, Kimberley (Kimberley).—Jan S. de Villiers & Seun, Kaapstad.
 8327/85—**Bruwer**, Johanna Elizabeth, 940910002009, Vincent Palotti-Verpleeginrigting, George (George).—P. M. Schoeman, George.
 1258/87—**Topping**, Peter Stuart, 2312235080105, 16 Devon Street, Simon's Town (Simon's Town).—John Preston, Simon's Town.
 1630/87—**Mostert**, Jacobus Pieter Francois, 1403305001005, Vierde Straat 38, Voëlkop, Hermanus; Mavis Maria Mostert, 1901280015007 (Hermanus).—A. S. Powell & Kelly, Swellendam.
 1828/86/3C—**Lewis**, Cyril Hughes, 0111055012004, 32 Church Street, Mossel Bay, Second and Final (Mossel Bay).—Miller Terblanche & Zietsman, Mossel Bay.
 3338/87—**Brown**, Frances Joyce Brown, 1309230019006, Knysna (Knysna).—Standardtrust, George.
 6819/87—**Smith**, Jemima Imrie, 2304230029005, George; William Vincent Smith (George).—Standardtrust, George.
 6325/87—**Fox**, Lillian Maud, 0409170001005, Oudtshoorn (Oudtshoorn).—Standardtrust, George.
 5947/87—**Thomson**, Grace Irvine, British Citizen, Plettenberg Bay (Plettenberg Bay).—Standardtrust, George.
 1785/87—**Van Zyl**, Petrus Jacobus, 1804135002008, Vuurpylsingel 26, Thornton; Martina Philippina van Zyl, gebore Strydom (Goodwood).—P. J. van Zyl, Parow.
 5433/87—**Potgieter**, Petronella Maria, 0108070017000, Huis Zonnekus, Milnerton.—Standardtrust, Kaapstad.
 5967/87—**Baard**, Willem, 3403055024007, Tuscaloosastraat 41, Saldanha; Belia Johanna Jacoba Baard, 3706060046005 (Vredenburg).—Standardtrust, Kaapstad.
 6331/87—**Kaden**, Charles Benjamin Ernst Robert, 2002205047008, 2 Huguenot Road, Franschoek; Anna Johanna Kaden, 2907280055009 (Paarl).—Standardtrust, Bellville.
 4905/87—**Davidson**, Doris Kathleen, 1703070026008, 10 Eghamhof, Egham Road, Wynberg (Wynberg, Bellville).—Standardtrust, Bellville.
 3294/87—**Law**, Constance Alice, Zerilda Steyn Memorial Home, Pinelands, Supplementary (Goodwood).—Standardtrust, Cape Town.
 4333/87—**Myburg**, Wouter Theron, 2610095002006, Besselaarweg 17, Worcester; Christina Francina Myburgh, 2807260039009 (Worcester).—Standardtrust, Kaapstad.
 9169/84—**Le Roux**, Gabriel Jacobus, 0404135008005, Eendrag, Montagu, Aanvullende (Montagu).—Standardtrust, Kaapstad.
 8965/86—**Vogt**, Ray De Villiers, 2108120048003, 3 Rutherglen Avenue, Newlands, Supplementary (Wynberg).—Standardtrust, Cape Town.
 8462/86—**Mackie**, Gladys Mary, 11067170038009, 6 Sherrington Court, Three Anchor Bay, Supplementary.—Standardtrust, Cape Town.
 931/87—**Houston**, Terence, 4001215100003, Klaasjagers Farm, Plateau Road, Cape Point, First (Simon's Town).—Standardtrust, Cape Town.
 4586/87—**Palvie**, Gert Jacobus, 2910065011007, Wienerstraat 74, Vasco; Susara Cecilia Palvie, 3309270056007 (Goodwood).—Standardtrust, Kaapstad.
 6532/87—**Beukes**, Hendrik Albertus, 1807175030003, Noeheep-Oos, Kamieskroon; Mathilda Maria Elizabeth Beukes, 2312250040000 (Springbok).—Standardtrust, Kaapstad.
 3836/87—**Truter**, Catharina Maria Sophia, gebore Holtzhausen, 1908190035009, Durbanweg 285, Bellville (Bellville).—Standardtrust, Kaapstad.
 3133/87—**Walker**, Phyllis Masters, 95802060W, Kenilworth House, 38 Greenfield Road, Kenilworth (Wynberg).—Standardtrust, Cape Town.
 6124/87—**Van der Bank**, Arnoldus Andries Jacobus, 3212125027001, Dumasweg 27, Kuilsrivier (Kuilsrivier).—Bankorptrust, Bellville.
 4011/87—**Vorster**, Helena Johanna, 1908070046001, Mooigesichtstraat 24, Chrismar, Bellville (Bellville).—Bankorptrust, Bellville.
 5731/87—**Van Zyl**, Jacobus Johannes, 1609145007008, Olyflaan 90, Worcester; Jacomina Elizabeth van Zyl, gebore De Swardt, 2406190005006 (Worcester).—Bankorptrust, Bellville.

NOORD-KAAP • NORTHERN CAPE

By die kantoor van die Meester, **KIMBERLEY**, en ook van die landdros van die distrik wanneer dit tussen hakies gemeld word.

By the office of the Master, **KIMBERLEY**, and also of the magistrate of the district when stated in parentheses.

- 354/87—**Du Plessis**, Roelof Stephanus, 1710275010000, Du Toitstraat 9, De Aar; Aletta Cornelia, 1608200010006 (De Aar).—Johan M. Swiegers & Kie., De Aar.
 102/87—**Van Rooyen**, Daphne, 3409200100006, Parkstraat, Prieska; Renier Johannes van Rooyen, 2907035028004 (Prieska).—Petrus J. Muller & Kie., Prieska.
 401/86—**Saaiman**, Anna Magrieta, 3601150054015, Jakarandastraat 28, Prieska (Prieska).—Van Niekerk & Groenewoud, Prieska.
 661/87—**Van der Merwe**, Adriaan Stephanus Meintjies, 3104145025000, Meiningstraat 5, Kimberley, Aanvullende; Gertruida van der Merwe, 2801200030004.—Bankorptrust, Bloemfontein.
 632/87—**Hansen**, Christiaan Frederick, 1902115012003, Plot 46, Longlands; Elizabeth Johanna Hansen, gebore Van Niekerk, 2810290004001 (Barkly-Wes).—Eerste Nasionale Bank, Kimberley.
 131/87—**Van Niekerk**, Gileam, 4011225031007, De Villiersstraat 68, De Aar, Verbeterde Eerste en Finale (De Aar).—Standardtrust, Kimberley.
 953/86—**Viljoen**, Willem Philippus, 2002225017008, Springfontein, Britstown (De Aar).—H. A. J. Lombard & Kie., Vredendal.
 729/87—**Wepener**, Antonie Christoffel, 2301015022007, McKenziestraat 159, Vryburg; Elizabeth Christina Wepener, 2310220013008 (Vryburg).—Volkskastrust, Kimberley.
 1091/86—**Janse van Rensburg**, Jan Albertus, 2411145030000, Petrusville, Verbeterde Eerste en Finale; Valeria Viola Janse van Rensburg, gebore Rudman, 2705120058005 (Phillipstown).—Volkskastrust, Kimberley.
 483/87—**Hubbart**, John William, 0512145002006, 27 Roper Street, Kimberley; Majorie May Hubbart.—M. M. Hubbart, Excom.

OOS-KAAP-EASTERN CAPE

By die kantoor van die Meester, GRAHAMSTAD, en ook van die landdros van die distrik wanneer dit tussen hakies gemeld word.

By the office of the Master, GRAHAMSTOWN, and also of the magistrate of the district when stated in parentheses.

- 2296/87—**Eigelaar**, Johannes Frederik, 1010305009001, 12de Laan 22, Cambridge, Oos-Londen; Johanna Etrechia Eigelaar, 2205300021006 (Oos-Londen).—Volkskastrust, Port Elizabeth.
- 2363/87—**Ellis**, William Cecil Desmond, 2511045013004, 25 Altona Road, Greenbushes, Port Elizabeth (Port Elizabeth).—Standardtrust, Port Elizabeth.
- 2111/87—**Pottas**, Reinier Johannes, 0305215003004, Thornstraat 4, Uitenhage (Uitenhage).—Boland Bank, Uitenhage.
- 2148/87—**Phillipotts**, George Edward, 1709075025002, 49 De Chavones Street, Kabega Park, Port Elizabeth (Port Elizabeth).—Standardtrust, Port Elizabeth.
- 2392/86—**Heathfield**, Alfred John, 0511215018009, 35 Second Avenue, Newton Park, Port Elizabeth (Port Elizabeth).—Jassinowsky & Shear, Port Elizabeth.
- 3554/86—**Grundling**, Louis Botha, 1412285010002, Whytesweg 1, Kirkwood, Tweede en Finale; Gertruida Janetta Grundling, gebore Strydom, 1303240014008 (Kirkwood).—Eerste Nasionale Bank van S.A., Port Elizabeth.
- 3256/86—**Nicholas**, Arthur Charles, 1701275062109, 26 Nuffield Close, Didsot, Oxfordshire, United Kingdom, Supplementary (Port Elizabeth).—First National Bank of S.A. Limited, Port Elizabeth.
- 1773/87—**Mentoor**, Rosemary (Rose), gebore Vitalinghum (Vitealingum), 3701160048013, Frazerstraat 1, Bedford; Isaak Michael Mentoor, 3112015047012 (Bedford).—Eerste Nasionale Bank van S.A., Port Elizabeth.
- 2809/87—**Fourie**, Thomas Cornelius, 26020550336009, Rutlandstraat 9, Algoapark, Port Elizabeth; Lea Magdalena Fourie, gebore Tait, 3807050032007 (Port Elizabeth).—Bankorptrust, Port Elizabeth.
- 2644/87—**Rich**, Henry Robins, 2412185002008, 13 Woltemade Street, Kabega Park, Port Elizabeth (Port Elizabeth).—Bankorptrust, Port Elizabeth.
- 1696/83—**Ferreira**, Jan Theodorus, 2806045011002, Thorntonstraat 39, Uitenhage, Supplementêre Eerste en Finale; Johanna Marthina Gezina Ferreira, 3302160033004 (Uitenhage).—Bankorptrust, Port Elizabeth.
- 530/87—**Flichtet**, Maria Catharina, 2402090053006, 45 Du Plooy Street, Rowallan Park, Port Elizabeth, Amended (Port Elizabeth).—Bankorptrust, Port Elizabeth.
- 1660/87—**Nel**, Gert Jeremias Michael, 1606175017006, Ou Groen Rivier, Posbus 213, King William's Town; Johanna Elizabeth Nel, gebore Botha, 1812020021009 (King William's Town).—Bankorptrust, Port Elizabeth.
- 2439/87—**Van Greunen**, Louis Willem, 0805055033007, Pro Ecclesiawoonstelle 4, Uitenhage; Christian Wesselina van Greunen, 1510250036007 (Uitenhage).—Bankorptrust, Port Elizabeth.
- 2440/87—**Jones**, Henry Bernard, 4810165109008, 3 Helen Road, Haven Hills, East London; Lynette Carol Jones, born Page, 5001240114085 (East London).—Bankorptrust, Port Elizabeth.
- 762/86—**Naude**, David Benjamin, 1203115014002, Welverdiend, Lady Grey, Tweede en Finale (Lady Grey).—Van Rooy & Van Rooy, Aliwal-Noord.
- 1686/87—**Williams**, Johanna, 1306290021005, Aberdeen; Tobias Johannes Williams, 0904045008003 (Aberdeen).—Volkskastrust, Port Elizabeth.
- 2931/74—**Paul**, Franz Carl, 067385386W, 26 Blaine Street, King William's Town, Supplementary; Freda Matilda Paul, 0709200044002 (King William's Town).—Squire Smith & Laurie, King William's Town.
- 975/87—**Sias**, Susan Louisa, 2709270037017, 3 Sass Street, Uitenhage; Norman Wilfred Sias, 2608115028019 (Uitenhage).—Whitesides, Grahamstown.
- 112/87/2D—**Taal**, Minnekus, 1803035083100, 4 Newlands Flats, 37 Fitzpatrick Road, East London; Maria Cornelia Taal (East London).—Russell Esterhuizen Lindsay & Sephton, East London.
- 1438/87—**Ikin**, Cecil Owen, 1806265029008, 51 Beach Road, Nahoon, East London (East London).—Russell Esterhuizen Lindsay & Sephton, East London.
- 1407/87—**Romans**, George, 2205295014008, 31 Pearce Street, East London; Aletta Romans, born Geyer (East London).—Drake Flemmer Orsmond & Vermaak, East London.
- 2571/87—**Barolo**, Eileen Blanche, born Brown, 1508110056000, 34 Morningside Road, Morningside, East London; Guerrino Barolo, 1512025013007 (East London).—Standardtrust, East London.
- 127/87—**Schonknecht**, Joseph Hermann Julius, 0908015022001, 8 Seventh Avenue, Gonubie; Otilie Henriette Scharlotte Schonknecht, 1101030027002 (East London).—John C. Blakeway & Leppan, Gonubie.
- 1647/87—**Lohberg**, Heinz Bernard Fritz, 1909235059103, 33 Prospect Road, Walmer, Port Elizabeth; Anneliese Lohberg, born Marnitz, 2904120022109 (Port Elizabeth).—Standardtrust, Port Elizabeth.
- 2813/86—**Kemp**, Colin Miles, 1004025017006, Robinson Street, Cathcart, Supplementary (Cathcart).—Standardtrust, East London.
- 2672/87—**Smith**, Mary McPherson, 0712240032003, 23 Jackson Street, West Bank, East London; Hugh Smith, 1112155031000 (East London).—Standardtrust, East London.
- 1903/87—**Renard**, Constance May, 9310220001006, Laubscher Park, Red Cross Home, Walmer, Port Elizabeth (Port Elizabeth).—Brown Braude & Vlok, Port Elizabeth.
- 1352/87/2D—**Harker**, John Archibald Sinclair, 114125042001, Port Elizabeth; Jane Sinclair Harker, gebore Johnson Rebson, 2003300040005 (Port Elizabeth).—Volkskastrust, Port Elizabeth.
- 2125/87—**Kilian**, Petrus Johannes, 0809065023008, Newtonstraat 66a, Newton Park, Port Elizabeth; Johanna Hester Kilian, gebore Van Zyl, 2101010033003 (Port Elizabeth).—Volkskastrust, Port Elizabeth.
- 813/87—**Du Plessis**, Johannes Zacharias, 2707275007001, Uitenhage; Maria Isabella du Plessis, gebore Marx, 2512300001007 (Uitenhage).—Volkskastrust, Port Elizabeth.
- 1732/87—**Nel**, Barend, 0207225014001, Greykerkwoonstelle 5, Adelaide (Adelaide).—Volkskastrust, Port Elizabeth.
- 1462/86—**Vorster**, Anna Susanna, gebore venter, 3801220085003, Sondermaam, Maclear; Johannes Jacobus Vorster (Maclear).—Hills & Vorster, Maclear.
- 255/87—**Humpel**, Wilhelm Eitel, 1711285025004, 4 Chadwick Street, Queenstown (Queenstown).—Laubser & Jocelyn, Queenstown.
- 1391/86—**Hayat**, Aisa, Cairncross Street, Korsten, Port Elizabeth, Amended First and Final (Port Elizabeth).—M. G. Moosagie, Port Elizabeth.
- 2466/87—**Human**, Laura Martha Ann, born Hewetson, 0809040004008, South African Red Cross Old Age Home, Fleet Street, East London (East London).—Standardtrust, East London.
- 2673/86—**Sampson**, Hazelton Maurice, 1008205031000, 7 Gordon Road, Southernwood, East London; Daphne Doreen Sampson, 1107310023009 (East London).—Cooper Conroy Bell & Richards Inc., East London.
- 1160/87—**Masterton**, Marjorie Holford, 0407310009003, 61 Eighth Avenue, Walmer, Port Elizabeth (Port Elizabeth).—Fidelity Bank, Port Elizabeth.
- 921/87—**Botha**, Johanna Maria, gebore Vosloo, 2909220042006 (Oos-Londen).—Volskastrust, Port Elizabeth.
- 349/85—**Charles**, Thelma Myrtle, born Dodds, 0411080025009, widow, 15 Beach Road, Humewood, Port Elizabeth (Port Elizabeth).—Fidelity Bank, Port Elizabeth.
- 1318/87—**Webber**, Melville Russell, 2202245011002, 12 Whiteside Street, Grahamstown; Margaret Ruth Webber, 2702210016001.—Wheeldon Rushmere & Cole, Grahamstown.

- 918/87/2D—**Condon**, Jennifer Mary, 4902120068005, 45 Penlee, Farewell Street, Durban (Durban).—Rushmere Noach & Partners, Port Elizabeth.
- 1245/87—**Parker**, Dorothy Violet, formerly Anderson, born Hay, 1012100034002, 5 Dyason Street, Mount Croix, Port Elizabeth (Port Elizabeth).—Fidelity Bank, Port Elizabeth.
- 1623/87—**Potgieter**, Stoffel Scheepers, 1303215011005, Dorchester, Alexandria, Eerste (Alexandria).—De Jager & Lordan, Alexandria.
- 258/87—**Labuschagne**, Maria Chatrina, 1512280039002, 4 Garth Street, Stoney Drift, East London (East London).—Russell Esterhuizen Lindsay & Sephton, East London.
- 2661/87—**Henning**, Johannes Jacob, 0706275009001, Huis Tarka, Tarkastad (Tarkastad).—Boland Bank, Cradock.
- 376/87—**Laden**, Leopold, 0405045007003, Jenwer Convalescent Home, St Mark's Road, East London (East London).—Syfrets Trust, Durban.
- 1745/87/1C—**Jacoby**, Norman Harold, 0504065026008, Stirling Lodge, Epsom Road, East London (East London).—The Bax Partnership, East London.
- 1910/87—**Burnett**, Harry Richard Barrick, 1911055006008, 36 Glenfields, 566 Old Road, Kabega, Port Elizabeth (Port Elizabeth).—P. W. Harvey & Co., Port Elizabeth.
- 1482/86—**Dolphin**, William Albert Emanuel, 0010105007008, Algoaweg 79, Uitenhage (Uitenhage).—M. W. Dolphin, Yellow Wood Park.
- 800/87—**Cheetham**, James Dinwoodie, 1702105021000, 1306 Mutualhof, Beach Road, Humewood, Port Elizabeth, Supplementary First and Final; Lilian Cheetham, born McCarthy, 1812170017005 (Port Elizabeth).—Standardtrust, Port Elizabeth.
- 2826/87—**Bessesen**, Grace Henrietta Violet, born Hopkins, 0106300010001, 41 Second Avenue, Newton Park, Port Elizabeth; Christian Frederick Bessesen, 0202165020001 (Port Elizabeth).—Standardtrust, Port Elizabeth.
- 1947/87—**Bennette**, Ernest Peter, 1409205031000, 4 Kloof Villas, Jutland Crescent off Park Drive, Port Elizabeth; Joyce Bathania Bennette, born Gertenbach (Port Elizabeth).—Standardtrust, Port Elizabeth.
- 3804/86—**Noades**, Amos Tom, 2108295044001, 2 Cecil Lloyd Street, East London (East London).—M. A. Noades, East London.
- 1999/87—**MacMillan**, William John, 1309015036001, 21 Sappershoek, Schoenmakerskop, Port Elizabeth (Port Elizabeth).—First National Bank of S.A., Port Elizabeth.
- 2207/87—**Davidson**, Charles Walter, 0109085007002, Park Towers, Rink Street, Port Elizabeth (Port Elizabeth).—First National Bank of S.A., Port Elizabeth.
- 1267/86—**Stevens**, William, 0105135013016, Buys Street, Dordrecht (Dordrecht).—D. R. Krummeck, Dordrecht.
- 549/87/C—**Van Wyk**, Pieter Daniel, 0608250001005, 1 Fox Road, Vincent, East London, Supplementary; Hendrik Stefanus van Wyk, 0610045002009 (East London).—Bate Chubb & Dickson Inc., East London.
- 3432/86—**O'Connell**, Norman Patrick Joseph, 0403255021004, 67 Durban Street, King William's Town; Laetitia O'Connell, 0406280017004 (King William's Town).—Hutton & Cook, King William's Town.
- 1307/87—**Botha**, Maria Catharina, 0303110002001, Greenwoodstraat 10, Berea, Oos-Londen (Oos-Londen).—Bosch, Oos-Londen.
- 2323/87—**Lelth**, James, 0801115030000, 27 Kennerley Park Old Age Home, Bonza Bay Road, Beacon Bay, East London; Mavis Matilda Leith, born Lloyd, 1511270021004 (East London).—Barclays National Bank, East London.
- 14/86—**Seward**, Herbert Crozier, 0212285002003, 2 Ailsa Court, St Peter's Road, Southernwood, East London, Second Supplementary (East London).—First National Asset Management & Trust Company, East London.
- 2227/87—**Thompson**, Hetty Edna, formerly Morrissey, born Martin, 2407280067005, 7 Kipling Road, Cambridge, East London; Robert Edward Thompson, 3008075074005 (East London).—Barclays National Bank, East London.
- 2232/87—**Warren**, Michael Alan, 1709125049002, 47 13th Avenue, Gonubie; Yvonne Warren, born Neuhoff, 2602270053003 (East London).—Barclays National Bank, East London.
- 2032/87—**Wood**, Oscar Eli, 0905065008005, Kei Bridge, Border South Africa (Komga).—Barclays National Bank, East London.
- 1787/87—**Barlow**, Walter Alfred, 1204215035004, Barmour, P.O. Hogsback (Cathcart).—Barclays National Bank, East London.
- 1931/87—**Dürheim**, Olga Pauline, born Lindemann, 2002140008008, 14 Coronation Road, Sunnyride, East London; Johannes Gustav Dürheim, 1204175012001 (East London).—Barclays National Bank, East London.
- 789/87—**Curnick**, Jeanette Lucille, born Turner, 3402060006009, 1 Gleneagles, Epsom Road, Stirling, East London.—Drake Flemmer Orsmond & Vermaak, East London.
- 691/87/1B—**Jordaan**, Paul Abraham, 1910295001001, Louis Trichardtstraat 35, Somerset-Oos (Somerset-Oos).—Abrahamson & Reynolds, Somerset-Oos.
- 443/85—**Von Bulow**, Eileen Bridget, born Daly, 3 Murray Avenue, Cambridge, East London (East London).—Syfrets Trust, Port Elizabeth.
- 543/87—**Goosen**, William Edward, 0509115020000, Suffolkstraat 5, Sentraal, Port Elizabeth; Anna Sarolina Elizabeth Goosen, gebore Meyer, 0904140020002 (Port Elizabeth).—G. P. Goosen, Uitenhage.

NATAL

By die kantoor van die Meester, PIETERMARITZBURG, en ook van die landdros van die distrik wanneer dit tussen hakies gemeld word.
By the office of the Master, PIETERMARITZBURG, and also of the magistrate of the district when stated in parentheses.

- 3871/87/1C—**Smith**, Harry, 0609015003002, 77 Eastview Road, Redhill, Durban North (Durban).—A. D. Millar & Kimber, Durban.
- 23/87—**Thomson**, Winifred Ann St. John, 0511080012004, 55 Kingsway Gardens, Warner Beach, Amended First and Final (Durban).—Barclays National Bank, Durban.
- 3129/87—**Hampson**, Garnet Rodder, 1403305015005, Mid Illovo (Richmond).—Barclays National Bank, Durban.
- 2324/87—**De Lange**, Maryna Gertruda Magdalena, 1906140022002, 144 Kenton, 90 West Street, Durban; Peter Frederick de Lange, 1704055023002 (Durban).—Barclays National Bank, Durban.
- 3977/87—**Harris**, Hilda Grace, 2510130047000, 33 Rustenburg, 126 Currie Road, Berea, Durban; Kenneth Vincent Harris, 2006305042009 (Durban).—Barclays National Bank, Durban.
- 4895/87—**Swart**, Petrus Jacobus Johannes, 1509055020001, 1 Somthya Court, Goble Road, Durban (Durban).—Bankorptrust, Durban.
- 7596/86—**Lewis**, Patricia Hallowes Addison, 1702260003009, 19 Ocean View Road, Winklespruit (Durban).—Barclays National Bank, Durban.
- 5440/86—**Ramdeo**, (Ramdeo Sookhoo), 800320174A, 52 Rawalpindi Road, Merebank; Kailaspathi (Durban).—Sham Singh, Durban.
- 3594/87—**Cheary**, Sidney Eric, 1209275049001, 632 Rydal Mount, Gillespie Street, Durban, First and Final Liquidaion and Distribution (Durban).—Chapman Dyer Inc., Durban.
- 3637/87—**Parasuraman**, Munsamy, 2412165083051, 22 Sanyo Place, Havenside, Chatsworth; Kandaruby Parasuraman, 36010700580054 (Chatsworth).—D. Soma, Durban.
- 2518/87—**Muckells**, Leonard Joseph, 2807255084002, 87 Seabrook, Smith Street, Durban (Durban).—Martin Dubois & Partners, Durban.
- 600/87—**Reynders**, Judith Susara Margareth, 2906080055003, 911 Windermere Centre, Windermere Road, Durban, First (Durban).—Berkowitz Kirkel Cohen Wartski Greenberg, Durban.
- 7349/86—**Cook**, Bertha Adolphinna Johanna, 2102200041004, 12 North Place, Warner Beach (Durban).—Barclays National Bank, Durban.
- 4782/87—**Francis**, Walter Albert, 0504145049004, Moreton Hall, Restholme, Kings Road, Pinetown (Pinetown).—Barclays National Bank, Durban.
- 5371/86—**Wardle**, Martyn John, 6102125216109, Kabeljokade 74, Meerensee, Richards Bay; Lynda Elizabeth Wardle, born Lawson, 6501200028109 (Empangeni).—Truter James de Ridder, Richardsbaai.
- 889/87/4B—**Ismail**, Amina (Amina Mahomed), 800028295, 50 Oaklands Road, Mountain Rise, Pietermaritzburg.—Smythe & Co., Pietermaritzburg.

- 2313/87—**Barnard**, Anna Maryna, 2508230016008, 186 Hesketh Drive, Pietermaritzburg.—J. Leslie Smith & Co., Pietermaritzburg.
 4710/83—**Morland**, Mary Cecilia Johanna, 10 July 1903, 14 Kitchener Road, Pietermaritzburg, Second and Final.—Hathorn, Cameron & Co., Pietermaritzburg.
 4171/87—**Martin**, Alice Maudie, 2411300060008, 42 Payn Street, Pietermaritzburg; John Cecil Martin, 1903185059007.—J. Leslie Smith & Co., Pietermaritzburg.
 2887/87—**Lowe**, William Henry, 2007085053109, 17 Long Road, Bisley Valley, Pietermaritzburg.—Standardtrust, Pietermaritzburg.
 3752—**Andersson**, Mona Ethel Ruth, 0010120016000, 196 Zwartkop Road, Pietermaritzburg.—J. Leslie Smith & Co., Pietermaritzburg.
 5835/86—**Lindeque**, Douglas Osbert, 1402195023004, Westhaven Nursing Home, Claridge, Second and Final.—Standardtrust, Pietermaritzburg.
 2625/87—**Phillips**, Gerald John, 2904045051001, Sipresstraat 17, Arbor Park, Newcastle (Newcastle).—Volkskastrust, Pietermaritzburg.
 5464/87—**Holmes**, Cyril Victor, 1304145034000, 16 Kempton, 178 Berg Street, Pietermaritzburg.—Barclays Personal Asset Management, Pietermaritzburg.
 4186/87—**Smith**, James Hood, 0404265021000, Polo Way, Underberg (Underberg).—First Personal Asset Management & Trust Co., Pietermaritzburg.
 4407/87—**Russell**, Magdalena Maria Dorothea, 0906265041002, 226 Retief Street, Pietermaritzburg.—Barclays Personal Asset Management, Pietermaritzburg.
 5471/87—**Nel**, Jacobus Rudolph, 20/11/12, Musgrave Nursing Home, Musgrave Road, Durban (Durban).—First Personal Asset Management & Trust Co., Pietermaritzburg.
 2781/87—**Selales**, George, 2211295023007, F7 Bencorrum Towers, Prince Street, South Beach, Durban (Durban).—Barclays National Bank, Pietermaritzburg.
 2840/87—**Gosling**, Harold Ralph Chamberlain, 1911235037006, 45 Acacia Avenue, Cleland, Pietermaritzburg.—Barclays Personal Asset Management, Pietermaritzburg.
 2993/87—**Small**, Charlotte Helen Davies, 0401080013105, Sunnyside Home, Sweetwaters Road, Pietermaritzburg.—Barclays Personal Asset Management, Pietermaritzburg.
 5603/86—**Ladner**, Cynthia Agnes, 1801130025000, 10 Athlone Heights, Port Shepstone, Amended (Port Shepstone).—S. C. Mortinson, Port Shepstone.
 7676/86—**Van Niekerk**, Gerard, 5007045077005, Bergsig 9, Huttonhoogte, Newcastle (Newcastle).—Pretorius & Bosman, Vrede.
 1663/87—**Van Vuuren**, Lucas Theodore, 2509105045007, 24 Dunford Road, The Grange, Pietermaritzburg; Pamelar Adelaine van Vuuren, born Griffin.—Shepstone & Wylie Tomlinson Francis, Pietermaritzburg.
 1762/87—**Lister**, Diana Rosalind Bennett, 1905100046001, 7 Barbara Avenue, Scottburgh South, Scottburgh (Scottburgh).—K. Lister, Johannesburg.
 3277/87—**Freese**, Herbert Frederik Wilhelm, 1402045029003, 87 Stott Road, Prestbury, Pietermaritzburg.—Boland Bank, Pietermaritzburg.
 4129/87—**Hayes**, David William, 1111025008008, 465a Oliver Lea Drive, Umbilo, Durban (Durban).—Barclays National Bank, Durban.
 1777/87—**Read**, Rose Minnie, 0502260021006, 15 Montgomery Road, Uvongo (Port Shepstone).—Barclays National Bank, Durban.
 5282/87—**Basford**, Gertrude Jane, 9003300002107, Kingsleigh Lodge, cnr Manning and McDonald Roads, Glenwood, Durban (Durban).—Barclays National Bank, Durban.
 3218/87—**Cheyne**, Phyllis Patricia, 1911210016009, 44 Sherwood, 219 Davenport Road, Durban (Durban).—Barclays National Bank, Durban.
 3452/87—**Loudon**, Robert, 9906055013006, Firenze, 513 Windermere Road, Morningside, Durban; Mabel Florence Loudon, 0304110015001 (Durban).—Barclays National Bank, Durban.
 530/87—**Wiggett**, Derek, 3209275110108, 72 Malaga, Pembroke Road, Durban (Durban).—Halse Havemann & Partners, Durban.
 3116/87—**Govender**, Ankammah Pauline, 2302220052052, 66 Road 107, Havenside, Chatsworth (Chatsworth).—D. Murguasen & Company, Chatsworth.
 1287/87—**Naidu**, Lutchman, 1289/87, 21 Eldon Street, Chatsworth (Havenside); Cheethamma Naidu, 2412230032059 (Chatsworth).—D. Muruga-sen & Company, Chatsworth.
 823/87—**Kennedy**, Christopher Thomas, 0711275041004, 21 Nazareth House, 82 South Ridge Road, Durban (Durban).—Hathorn & Fannin, Durban.
 850/87—**Narainsamy**, Balakrishna, 4802075175054, 4 Statesman Drive, Havenside, Chatsworth; Kogielambal Narainsamy, 800403389A (Chatsworth).—D. Soma, Durban.
 5614/85—**Padavattan**, Perumal, 2604035072054, 21 Flummery Place, Moorton, Chatsworth; Chinthamoney Padavattan, 3312240088050 (Chatsworth).—Thorpe & Hands, Durban.
 1742/87—**Abrahams**, Anna, 0511120030008, 307 Davenport Road, Durban (Durban).—Pim Goldby, Durban.
 1224/86—**Goburdhan**, Kamalpersad, 3709175080053, 233 Quarry Road, Springfield, Durban, First and Final Liquidation; Sonia (Durban).—P. R. Maharaj & Co., Durban.
 728/87—**Lindsay**, Alexander Steven, 1110115033108, 19 Carisford, 434, Wondermere Road, Durban (Durban).—R. J. H. Linton & Co., Durban.
 3585/87—**Taylor**, Basil Arthur Burrows, 1801055027007, 90 Hazeldene Road, Sea View, Durban (Durban).—W. B. Thomas & Co., Durban.
 2538/87—**Roopsingh**, Mahabeer, 8 Winchester Road, Belvedere, Harare, Zimbabwe; Mabel Roopsingh (Durban).—Legator, McKenna Incorporated, Durban.
 1732/87—**Moola**, Hawa, 2709140038054, 13 Mosque Lane, Dannhauser; Mahomed Suleman Moola, 2710255046056 (Dannhauser).—Legator, McKenna Incorporated, Durban.
 7313/85—**Naude**, Stephanus Johannes, 1409195017001, Mulborough Court, Marine Parade, Durban (Durban).—S. J. Naude & Klopper, Alberton.
 4344/86—**Dalias**, James Alexander, Port Farm, Port Road, Norton, Zimbabwe, Amended (Durban).—Millar & Reardon, Durban.
 2762/87—**Bianche**, Jurie Johannes Christiaan, 0409035005001, 616 The Gables, Esplanade, Durban (Durban).—Palmer's Trust Investments and Estate Administrators, Durban.
 2719/87—**Booth**, Harold, 9507195001008, 2 Southfield Drive, Westville (Pinetown).—Syfrets Trust, Durban.
 5455/87—**Blackman**, Doreen, 1708230028000, 804 Kingsford, Esplanade, Durban (Durban).—Standardtrust, Durban.
 1343/87—**Dinsdale**, Pearl, 0812140032002, Gem Village, Irene (Pietermaritzburg).—R. S. Dinsdale, Athlone Park.
 2139/86—**Van Niekerk**, Barend Erasmus, 2908095002004, 20 Winchelsea Avenue, Wentworth, Durban; Gertruida Isabella, 3507150002005 (Durban).—Marcus Lewis Robinson & Goulding, Durban.
 7552/86—**Bayat**, Ebrahim Dawood, 800386866A, Flat 12, 449 Church Street, Pietermaritzburg; Mariam Bayat, 800232032, deceased.—Sayed & Lockhat, Durban.
 1150/87—**Kimpton**, Edmund William, 0308165008100, 82 Chartwell, Ridge Road, Durban (Durban).—Arthur Young & Company, Durban.
 3014/87—**Bissessor**, Sunjeeth, 3203255049055, 103 Glenardle Avenue, Sydenham, Durban; Dorothy Elizabeth Bissessor, 3705180073059 (Durban).—Shano Singh & Co., Durban.
 447/87—**Badasse**, Ramkaran, 2603205060054, 21 Bardai Avenue, Reservoir Hills, Durban; Tharadevi Badasse, 3609050053052 (Durban).—Suren Lutchman, Vallaraman & Company, Verulam.
 6491/86—**Naidoo**, Narsimmulu, 800328107A, 50 Parbhani Road, Merebank, Durban; Pakiriamma Naidoo, 3001040056058 (Durban).—Maharaj, Lala & Company, Durban.
 1399/87—**Naidoo**, Govindsami, 2709015082054, House 9, Road 1117, Chatsworth; Lutchmee Naidoo, 3903250088053 (Chatsworth).—Himal Tugh and Company, Ghatsglen.
 7233/85—**Ally**, Kuthboodeen Hassen, 2302055066052, 4 Hooghli Place, Merebank, Durban (Durban).—Farouk Vahed, Harie & Company, Durban.

- 3836/87—**Naidoo**, Gengiah, 3606025092058, 10 Guardbridge Gardens, Stonebridge, Phoenix; Saravasvathy Naidoo, 4002200106054 (Durban).—Krish Govender & Company, Durban.
- 3124/87—**Deighton**, Mary Anne, 2605240054001, 6 Hibernia Road, Bellair, Durban (Durban).—Cowley & Cowley, Durban.
- 685/87—**Thanarayan**, Joseph Anthony, 360424076050, House 3, Road 705, Chatsworth; Patricia Ellen Thanarayan, 411150084052 (Chatsworth).—Dass, Vedan & Partners, Durban.
- 2486/87—**Ranjith**, Ramlochan, 3901055120055, 165 Himalaya Drive, Shallcross, Durban; Dhilawathy Ranjith, 4004030131054 (Chatsworth).—Chris Pather & Associates, Durban.
- 225/78/3C—**Pugin**, George Reginald Caltany, 1110275040018, 46 Croton Road, Wentworth, Amended First and Final (Durban).—A. Christopher & Co., Durban.
- 2276/87—**Singh**, Bachan Bedesi, 1810145039054; Sithawathi Singh, 4001290048051 (Chatsworth).
- 448/87—**Jasat**, Essop, 800398687, 4 Jacaranda Avenue, Mobeni Heights (Durban).—Sayed & Lockhat, Durban.
- 3357/87—**Miles**, Clifford Duncan, 27015155043005, 24 Browns Avenue, Sherwood (Durban).—Shepstone & Wylie, Durban.
- 6900/86—**Wood**, Thomas, 0901305010000, 15 Kingfish Road, Leisure Bay, South Coast (Port Shepstone).—M. T. Brereton, Port Edward.
- 5460/86—**Swart**, Jacobus Paulus Fouché, 5012065033003, Oosstraat 16, Vryheid; Julia Katharina Swart, 5606170056005 (Vryheid).—Bankorp-trust, Pretoria.
- 5461/86—**Swart**, Julia Johanna Katharina, 5606170056005, Oosstraat 16, Vryheid; Jacobus Paulus Fouché Swart, 5012065033003 (Vryheid).—Bankorp-trust, Pretoria.

ORANJE-VRYSTAAT • ORANGE FREE STATE

By die kantoor van die Meester, BLOEMFONTEIN, en ook van die landdros van die distrik wanneer dit tussen hakies gemeld word.

By the office of the Master, BLOEMFONTEIN, and also of the magistrate of the district when state in parentheses.

- 2457/86—**Pule**, Moses Mafole, 1031338, Rampastraat 57, Koppies; Adelina Limakatso Pule, gebore Letsaba, 156615 (Koppies).—Piet de Wet & Seuns, Koppies.
- 951/87—**Venter**, Jan Adriaan, 1803065020006, Palierstraat, Jacobsdal; Sarah Susanna Venter, 1608290015006 (Jacobsdal).—A. H. de Villiers, Jacobsdal.
- 889/87—**Manolas**, Helen, 3405100038007, 3 Athlone Avenue, Westdene, Bloemfontein.—Du Toit & Ross, Jagersfontein.
- 2721/86—**Radley**, Charles Stevens, 0911015007006, Merinovaal, Senekal (Senekal).—N. O. Eolofe & Kie., Senekal.
- 1236/86—**Laubscher**, Benoni Malan, 113085012004, Engelbrechtstraat 3, Bainsvlei, Bloemfontein, Gewysigde Tweede en Finale.—Syfrets Trust, Kimberley.
- 1377/87—**Hillebrand**, Jozef Johannes Albertus, 9902045002001, Fairview, distrik Brandfort, Eerste en Finale en Her-distribusie (Brandfort).—Hendrikz & De Vletter, Brandfort.
- 194/87—**Hipkin**, Anna Sophia, gebore Kriek, 0203030018006, weduwee, Avondvrede-ouetehuis, Vrede (Vrede).—P. J. Dietrichsen, Villiers.
- 752/87—**Theron**, Aroma, 4601310019006, Brandstraat 29, Ficksburg; Louis Gerrit Anton, 4405105041004 (Ficksburg).—Hibbert, Welkom.
- 1366/87—**Nel**, Johanna Alida, 2302090026004, President Krugerweg 9, Parys; Johan Dawid Nel, 1610265030002 (Parys).—Volkskastrust, Klerksdorp.
- 2110/86—**Anderson**, Hercules Johannes, 3604235001001, Qwa-Qwa Hotel, Puthaditjaba, Eerste Supplementêre tot die Eerste en Finale (Ladybrand).—Eerste Nasionale Bank, Bloemfontein.
- 2569/86—**Uys**, Anna Gesina Hendrika, voorheen, Krog, gebore Uys, 1407310015009, Eksteenstraat, Memel (Memel).—Eerste Nasionale Bank, Bloemfontein.
- 498/87—**Felske**, Reinhold Hermann August, 1404195046100, Inneslaan 28a, Bloemfontein, Eerste; Ingeborg Meta Augusta Felske, gebore Luck, 2003240029100.—Van der Merwe & Sorour, Bloemfontein.
- 1150/87—**Pienaar**, Marthinus Andreas Lodewickus, 2702045019006, Voortrekkerstraat 63, Paul Roux; Elsie Wilhelmina Philippina Pienaar, gebore Van Heerden, 3112070022009 (Paul Roux).—Volkskastrust, Bloemfontein.
- 183/87—**Van Deventer**, Hendrik Nicolaas Christoffel, 3910105018003, Patryfontein, Kestell; Jacoba Nicolina van Deventer, gebore Swart, 3110240007009 (Kestell).—Volkskastrust, Bloemfontein.
- 1188/87—**Johnson**, Stanley John Robert, 1504015014004, 37 Harry Smith Street, Bloemfontein.—Bloemboard, Bloemfontein.
- 1806/87—**Snyman**, Christina Douwlina, voorheen Van Wyk, gebore Van Wyk, 0905290014000, Brandstraat 27, Brandfort (Brandfort).—Hendrikz & De Vletter, Brandfort.
- 1248/87—**Scholtz**, Gertruida Susanna, 1401250011003, Mooihawe, Bloemfontein.—J. M. Strauss, Universitas.
- 1013/87—**Coertzen**, Anna Catharina, 0807090032002, Ons Woning, Ossewastraat, Petrusburg (Petrusburg).—Hugo & Terblanche, Petrusburg.
- 2608/84—**Sadie**, Maria Magdalena, voorheen Human, gebore Humphries, 1109170008005, Duncanstraat 3, Fichardt Park, Bloemfontein (Theunissen).—F. B. Coetzer, Theunissen.
- 2340/86—**Naude**, Paul Johannes Jacobus, 0412075007002, ongetroud, Braklaagte, Senekal (Senekal).—N. O. Oelofse & Kie., Senekal.
- 715/85—**Bornman**, Burger Adriaan, 1304040005006, Kiaatstraat 14, Meyerhof, Bothaville, Supplementêre (Bothaville).—G. P. Nieuwoudt & Vennote, Bothaville.
- 976/87—**Minnaar**, Hermina Catharina, 1103150015007, plaas Moedersorg, distrik Wesselsbron; Andries Hercules Minnaar, 0502035003008 (Wesselsbron).—Len Niemand & Kie., Klerksdorp.
- 1240/87—**Koch**, Sophia, 4012220086004, Rietfonteinweg 59, Glen Marais, Kempton Park; Abraham Johannes Koch, 3912015053005 (Kempton Park).—A. J. Koch, Bloemfontein.

INSOLVENSIEWET- EN MAATSKAPPYWETTE-KENNISGEWINGS INSOLVENCY ACT AND COMPANIES ACTS NOTICES

Vorm/Form J 28

BOEDEL OF MAATSKAPPYE WAT VOORLOPIG GESEKWESTREER OF GELIKWIDEER IS

Ingevolge artikel 17 (4) van die Insolvensiewet, 1936, en artikel 356 (1) van die Maatskappywet, 1973, word hierby deur die Meesters van die Hooggeregshof kennis gegee dat die boedels of maatskappye hieronder vermeld voorlopig op las van genoemde Hof gesekwestreer of gelikwieder is.

Die besonderhede word verstrekk in die volgorde: Nommer van boedel/maatskappy; naam en beskrywing van boedel/maatskappy; datum waarop en afdeling van hof waardeur order gemaak is en op die aansoek van.

ESTATES OR COMPANIES SEQUESTERED OR WOUND UP PROVISIONALLY

Pursuant to section 17 (4) of the Insolvency Act, 1936, and section 356 (1) of the Companies Act, 1973, notice is hereby given by the Masters of the Supreme Court that the estates or companies mentioned below have been sequestered or wound up provisionally by order of the said Court.

The particulars are given in the following order: Number of estate/company; name and description of estate/company; date upon which and division of court by which order made and upon the application of.

T2726/87—**Rofo Gears (Pty) Ltd**, registered address at Second Floor, Hees and Van Loggerenberg Building, 23 Long Street, Kempton Park. 15 September 1987, Transvaal Provincial. *Ex Parte*.

T2716/87—**Fondse**, Johan Albert, Huis 22, Albion. 8/9/87, Transvaalse Provinsiale. Theodorus Jacobus Fondse.

T2694/87 ASR 2—**Laubscher**, Johannes Petrus Kruger, Van Riebeeckstraat 145, Potchefstroom. 17/9/87, Transvaalse Provinsiale. Linda Laubscher.

T2706/87—**Van den Berg**, Johannes Jurie, Adolf Schneiderlaan 65, Krugersdorp. 15 September 1987, Transvaalse Provinsiale. Jan Jacobus Nel.

T2605/87—**Snyman**, Rayne, an adult male ceiling contractor trading as Aclaire Ceilings and residing at 55 Bamboes Street, Weltevreden Park, Roodepoort. 1/9/87, Witwatersrand Local. Ricardo York.

T2705/87—**Bishop**, Colin Raymond and Aletta Catharina Maria Nortje, trading together in partnership under the name and style of Tweefontein Slaghuis, Colin Raymond Bishop, first respondent, 694 Windsor Road West, Cluver, Witbank, Aletta Catharina Nortje, second respondent of the same address. 15/9/87, Transvaal Provincial. Gregg Allen Bishop.

T2724/87 ASR 2—**O'Callaghan**, Kydie Martinus Daniel (eerste respondent), Maria Elizabeth O'Callaghan, getroud met eerste respondent binne gemeenskap van goedere en beide woonagtig te Hoewe 118, Haakdoorn. 15/9/87, Transvaalse Provinsiale. Pieter Jacobus Swart.

T2685/87—**The Performing Arts Workshop Trust**, an incorporated trust not of gain with trust number 5/29850418, and a fund raising organisation registered as such under number FN011005190007. 15 September 1987, Witwatersrand Local Division. Screen Machine (Pty) Ltd.

T2696/87—**Kleinklippot Boerdery (Edms.) Bpk.**, met geregistreerde adres te Centenarygebou 410, Bureaulaan, Pretoria. 15 September 1987, Transvaalse Provinsiale. Die Standard Bank van Suid-Afrika Bpk.

T2695/87—**Joubert**, Johannes, van die plaas Mosterthoek 25, Lydenburg. 15/9/87, Transvaalse Provinsiale. Theunis Gerhardus van der Walt.

T2725/87—**Papenfus**, Gerhardus Pienaar en Maria Magdalena Papenfus, albei van Angelierstraat 34, Uitbreiding 9, Heidelberg, getroud binne gemeenskap van goedere. 15/9/87, Transvaalse Provinsiale. Benjamin Dawid Backhouse.

T2655/87—**De Necker**, Johanna Catherina, Bushstraat 17b, Ladanna, Pietersburg. 8 September 1987, Transvaalse Provinsiale. Johannes Christiaan Frederick Beukes.

B409/87—**Muller**, Willem Johan George, van Rienzisstraat, Clocolaan. 17 September 1987, Oranje-Vrystaatse Provinsiale. Johannes Petrus Muller.

B408/87—**Lombaard**, Sybrandt Lourens, van Mareestraat 12, Riebeeckstad, Welkom. 17 September 1987, Oranje-Vrystaatse Provinsiale. Sybrandt Lourens Lombaard.

B409/87—**Muller**, Willem Johan George, van Rienzisstraat, Clocolaan. 17 September 1987, Oranje-Vrystaatse Provinsiale. Johannes Petrus Muller.

B408/87—**Lombaard**, Sybrandt Lourens, van Mareestraat 12, Riebeeckstad, Welkom. 17 September 1987, Oranje-Vrystaatse Provinsiale. Sybrandt Lourens Lombaard.

B407/87—**Vermeulen**, Elsje Magdalena, van Cypreslaan 1, Bloemfontein. 17 September 1987, Oranje-Vrystaatse Provinsiale. Gysbert Theunis Johannes Vermeulen.

B405/87—**Van Rensburg**, Allan Daniel, woonagtig te Cambridgestraat 258, Bethlehem. 17 September 1987, Oranje-Vrystaatse Provinsiale. Blackrose Investments (Pty) Ltd.

B404/87—**Coetzer**, Stephanus, woonagtig te Blesbokstraat 1, Kellies View, Bloemfontein. 17/9/87, Oranje-Vrystaatse Provinsiale. Antoinette Coetzer.

B406/87—**Van Jaarsveld**, Samuel Jacobus, woonagtig te Klein Nootgedacht, Petrusburg. 17/9/87, Oranje-Vrystaatse Provinsiale. Hugo & Terblanche.

B411/87—**Viviers**, Carolus Johannes, woonagtig te Paul Winter en Devonstrate, Bultfontein. 17/9/87, Oranje-Vrystaatse Provinsiale. Louisa Christina van den Berg.

B403/87—**Krause**, Andries, woonagtig te Hoewe 1, Roodewal, Bloemfontein. 17/9/87, Oranje-Vrystaatse Provinsiale. Adolf Hitler Lombard.

B410/87—**Enslin**, Nicholaas, woonagtig te Kaistraat 10, Sasolburg. 17/9/87, Oranje-Vrystaatse Provinsiale. Anthon Christiaan de Wet Voigt.

N339/87—**Hammond**, Derek Mitchell, Flat 3, Zam Zam Manzil Buildings, 17 St Aidens Road, Overport, Durban. 25 August 1987, Durban and Coast Local. Anand Singh.

C583/87—**Mike's Panel Shop (Pty) Ltd**, registered office at c/o Baker Musikanth, Eighth Floor, 2 Long Street, Cape Town. 17 September 1987, Cape of Good Hope Provincial.

C532/87—**Saayman**, Solomon Wilhelm, trading as Saayman's Security, at Bertie Avenue, Epping Two. 28 August 1987, Cape of Good Hope Provincial. Xabisile Simon Plaatjies.

C572/87—**De Villiers**, David Abraham, 'n boer woonagtig te Anyskap, Tulbagh. 11 September 1987, Kaap die Goeie Hoop Provinsiale. Dalina Annette de Villiers, gebore Mouton.

C562/87—**Botticelli (South Africa) (Pty) Ltd**, registered office at c/o Fisher Hoffman & Stride, Citicom House, 168 Bree Street, Cape Town. 9 September 1987, Cape of Good Hope Provincial. Maurice Lancelot Jenkin.

C573/87—**Bester**, Johannes Barend Frederick, woonagtig te Fisantekraal, werksaam by Corobrick (Edms.) Bpk., Fisantekraal, Durbanville. 11 September 1987, Kaap die Goeie Hoop Provinsiale. Lukas Daniël Visser.

C561/87—**Sealing and Thermal Products (Pty) Ltd**, carrying on business at Bremen Close off Borchards Quarry Road, D. F. Malan Industria, Cape. 8 September 1987, Cape of Good Hope Provincial. William Alexander Adams.

C574/87—**Solomon**, Lynda Anne, residing at Dreyersdal Road, Bergvliet. 11 September 1987, Cape of Good Hope Provincial. Barbara Ann Dean.

C584/87—**Stander**, Theunis Jacobus, residing at Riviera Farm, Paarl. 17 September 1987, Cape of Good Hope Provincial. Thorn Lighting S.A. (Pty) Ltd.

C563/87—**Rossouw**, Andre Jacobus en Lorette Diane Rossouw, woonagtig te Boomstraat 13, Bothasig. 9 September 1987, Kaap die Goeie Hoop Provinsiale. Cornelia Sophia Rossouw.

C580/87—**Snyman**, Johannes Jacobus, residing at I The Bend, Pinelands. 16 September 1987, Cape of Good Hope Provincial. Pudney's Fur and Curio Company.

C578/87—**Communications and Technical Services (Pty) Ltd**, registered office at 6b Bellpark, De Lange Street, Bellville. 17 September 1987, Cape of Good Hope Provincial. Alan Healey.

C577/87—**Abass**, Washiela, residing at Desirade, Tanner Road, Crawford. 16 September 1987, Cape of Good Hope Provincial. Zhaun's Textile & Clothing (Pty) Ltd.

C576/87—**Jones**, Desraye Anita Louise, residing at 5 Heron Waters, Blaauwberg Road, Table View. 11 September 1987, Cape of Good Hope Provincial. John Charles McAuley.

- C575/87—**Victor, Jan Hendrik**, woonagtig te die plaas "Waterval" geleë in die distrik Villiersdorp vir die sekwestrasie van Respondent se boedel. 11 September 1987, Kaap die Goeie Hoop Provinsiale. Maria Elnastien Victor.
- C570/87—**Yunger-Levi, Issy**, formerly residing at 36 Evremonde Road, Plumstead, presently incarcerated at Pollsmoor Prison. 11 September 1987, Cape of Good Hope Provincial. Selwyn Brickman.
- C569/87—**Worcester Auto Electric (Edms.) Bpk.**, geregisteerde kantore te p/a Claasen Cohen & Du Toit, Stockenströmstraat, Worcester. 8/9/87, Kaap die Goeie Hoop Provinsiale, Ignatius Wilhelm van der Merwe.
- C568/87—**Heyns, Johan Willem Hendrik**, handeldrywende as Doringvlei, Algemene Handelaar te Doringvlei, Vredendal. 11 September 1987, Kaap die Goeie Hoop Provinsiale. Vredendal Motors.
- C565/87—**Retief, Pierre Rossouw**, woonagtig te Huisingstraat 12, Welgemoed. 10 September 1987, Kaap die Goeie Hoop Provinsiale. Jacobus Albertus Retief.
- C559/87—**Texspray (Cape) (Pty) Ltd**, Registered office at c/o Valentine Sargeant & Co., Eighth Floor, Boland Bank Building, Lower Burg Street, Cape Town. 4 September 1987, Cape of Good Hope Provincial Division. Texspray (Cape) (Pty) Ltd.
- K86/87—**Benade, Alinda Elizabeth**, gebore Van der Walt, woonagtig te Van der Stelstraat 16, Hillcrest, Kimberley. 25 September 1987, Noord-Kaapse. Johannes Stephanus Verreyne.
- E206/87—**Botha, C. de J.**, residing at 22 Smit Street, Central, Port Elizabeth. 16 September 1987, South-Eastern Cape Local. Alfred Daniel Davis.
- E204/87—**Fourie, Gert Cornelis**, in diens van Avbob, Graaff-Reinet. 17 September 1987, Oos-Kaapse. Gem Implements (Edms.) Bpk.
- N374/87—**Pickford, Margaret Ann**, Pickford Estates, Shongweni, Natal. 14 September 1987, Natal Provincial. The Standard Bank of S A Ltd.
- N375/87—**Aumüller, Rensche**, 51 Crestmore, Sol Harris Crescent, North Beach, Durban. 11 September 1987, Durban and Coast Local. John Gemmill.
- N376/87—**Diamond Glass and Aluminium (Pty) Ltd**, Fourth Floor, Fenton House, Fenton Road, Durban. 11 September 1987, Durban and Coast Local. Desmond George Turton.
- N384/87—**Raleigh, Peter James**, Little Harmony, Mid Illovo, District of Richmond. 17 September 1987, Natal Provincial. Mark Lehman.
- N385/87—**Radiosource (Pty) Ltd**, registered office at Benham and Associates, Outfitters Building, Brickhill Road, Durban. 17/9/87, Durban and Coast Local. *Ex parte*.
- N386/87—**Ismail, Murad Omar**, trading as Trends Boutique at 156 Queen Street, Durban resides at Flat 16, Kenilworth Mansions, 168 Kenilworth Road, Overport, Durban. 16 September 1987, Durban and Coast Local. Rashid Ahmed.
- T2671/87—**Hoffmann, Dirk Jacobus**, an adult male and clerk at the South African Transport Services and residing at, 36 Geraldine Court, Cnr. Quartz and Wolmarans Streets, Joubertpark, Johannesburg. 3 September 1987, Witwatersrand Local. Pieter Andries Foley.
- T2771/87—**Calais, Arthur Emmanuel**, First Respondent an adult male businessman of No. 64 Somerset Street, Kensington, Johannesburg. Vera Velasis, Second Respondent an adult female public trader, trading as The Pink Flamingo Restaurant, Lower Level, Carlton Centre, Johannesburg and resident at 64 Somerset Street, Kensington, Johannesburg. 22 September 1987, Witwatersrand Local. Cleanthis Andreas Roussos.
- T2823/87—**Parsons, Larry Glen**, an adult male businessman of 38 Dibberic Drive, Bassonia, Johannesburg. The respondent is married out of community of property. 22/9/87, Witwatersrand Local. Willem Hermanus Byleveldt.
- T2830/87—**Sher, Maurice Mendel**, an adult male businessman of 75 Roslin Street, Sydenham, Johannesburg. 29 September 1987, Witwatersrand Local. Mendel Levin.
- T2831/87—**Assad, Kenneth John**, an adult male estate agent resident at, 8 Naivasha Road, Sunninghill Park, Sandton, married out of community of property to Victoria Adrienne Assad. 29 September 1987, Witwatersrand Local. John Francis Bolus.
- R2832/87 ASR 1—**Comcorp (Pty) Ltd**, having its registered office at 185 Katherine Street, Eastgate, Sandton. 22/9/87, Witwatersrand Local. W. T. J. Moolman, L. Matuson.
- T2833/87—**Keats Meat Products CC**. 29 September 1987, the Magistrate's Court for the District of Randburg. Donald Charles Goschen.
- T2841/87—**Du Toit, Pieter Dirk**, Van die plaas Soutpansdrift, distrik Brits. 29 September 1987, Transvaalse Provinsiale. Maria Francina du Toit.
- T2842/87—**Van der Veen, Frederik Gerrit (Jnr)**, Brentwood, Howick, Natal. 29 September 1987, Transvaalse Provinsiale. Frederik Gerrit Hendrik van der Veen (Snr.).
- T2843/87—**Wheeler, Jacob Marthinus Lodewyk**, Luttighstraat 413, Pretoria-Wes. 29/9/87, Transvaalse Provinsiale. Wilhelmina Andriena Wheeler.
- T2828/87—**Industrial Investments and Development Company (Pty) Ltd**, has its registered office at Plot 7, Merrowlane, Merrowdown, Sandton. 24/9/87, Witwatersrand Local. Charles Stanhope Courtney-Clarke.
- T2638/87—**Univo Motors (Pty) Ltd**, has its registered Head Office at care of Du Plessis and Smit, 501 De Korte Building, 46 De Korte Street, Braamfontein, Johannesburg. 8 September 1987, Witwatersrand Local. Edward Max Singer in his capacity as the duly authorised provisional Trustee in the Insolvent Estates of the James Economides Family Trust and James Economides.
- T2758/87—**Gouws, Johan La Grange**, 'n meerderjarige geskiede man wat woonagtig is binne die Regsgebied van bogemelde Agbare Hof te Imbaliwoonstelle 105, Tudhopelaan, Berea, Johannesburg, 15 September 1987, Witwatersrandse Plaaslike. Sarel Francois Joubert.
- T2789/87 ASR 3—**Ferreira, Suzette Marie**, Falcon Ridge, Vereeniging. 22 September 1987, Transvaalse Provinsiale. Lodewyk Christiaan Pieteresen.
- T2797/87—**Natie King (Pty) Ltd**, trading as Team Sports having its principal place of business at Shop 13, Greenside Centre, 127 Greenway, Johannesburg, and having its registered office at care of H. Kagan, 67c Bedford Avenue, Benoni. 22 September 1987, Witwatersrand Local. *Ex parte*.
- T2788/87 ASR 3—**Ferreira, Ignatius Wilhelm**, 1ste Respondent en Cornelia Johannea Ferreira, gebore De Beer, 2de respondent, albei van Freiburgstraat 14, Evander, getroud buite gemeenskap van goedere met 1ste respondent. 22 September 1987, Transvaalse Provinsiale. J. P. Marais.
- T2769/87—**Tobler, Max**, and adult male divorce residing at 66 Salwood Road, Bramley, Johannesburg. 15 September 1987, Witwatersrand Local. Judith Booyens Fouche.
- T2728/87—**7A Construction (Pty) Ltd**, met geregisteerde kantoor te Constantiapark, Besigheidsentrum 105, Douglas Scholtzstraat, Constansia-park, Pretoria. 15/9/87, Transvaalse Provinsiale. J. F. van der Merwe.
- T2770/87—**Jordaan, Wilhelmina Johanna**, an adult female, married out of community of property, and carrying on business as Wool and Hobby Centre, at 31 (i) Loch Street, Meyerton. 22 September 1987, Witwatersrand Local. Gert Hendrik Johan Venter N.O.
- T2809/87—**Watts, Paul Louis**, 8 Totius Street, Kilprivierdorp, Meyerton. 22 September 1987, Transvaalse Provinsiale. David Israel Rootenberg.
- T2709/87—**Callis, Paris Plot 27**, Kameeldrif-Oos, Pretoria. 14 September 1987, Transvaalse Provinsiale. Pretoria Pools (Edms.) Bpk.
- T2648/87—**Ericson, Ronald Ivan**, Bezuidenhoutlaan 675, Booyens, Pretoria. 8 September 1987, Transvaalse Provinsiale. Francois Petrus Nell.
- T2658/87 ASR 3—**Puren, Lourens Botha**, Ben Van Tonderlaan 278, Villieria, Pretoria. 8/9/87, Transvaalse Provinsiale. Andrew Peter Cooks.
- T2759/87—**Goodwin, Robert Evan**, an adult male, a Diesel Electric Fitter, a bachelor of 27 13th Avenue, Northmead, Benoni. 22 September 1987, Witwatersrand Local. Stanley Grant McInden.
- T2780/87—**Putar, Andrea Boris**, an adult male businessman and company director presently residing at 15 Rynfield Road, Agricultural Holdings, Benoni. 15 September 1987, Witwatersrand Local. Bauscher Structural Engineering (Pty) Ltd.
- T2808/87—**Wood, Roberta Victorina**, born Van Oudsthoorn, resides at 9 Hartley Street, Runfield, Benoni, Transvaal and is married to Ian Donald Wood by Antenuptial Contract. 22/9/87, Witwatersrand Local. Mary Agnes Jones.
- T2807/87—**De Vantler, Paul Bernard**, an adult male, businessman residing at 38 Buckingham Road, Kensington, Johannesburg. 22/9/87, Witwatersrand Local. John Allen.
- T2790/87—**Fletcher, Dudley Crichton**, who carries on business as a manufacturer's representative of, c/o Dudley Fletcher Agencies, Eight Floor, Pan Africa House, 77 Troye Street, Corner Jeppe, Johannesburg. 22 September 1987, Witwatersrand Local. Terme Investment and Finance Company (Pty) Ltd.

- N364/87—**Jacobsz**, Ignatius Stephanus, Zandspruit, District of Utrecht, Natal. 10/9/87, Natal Provincial. Daniël Johannes van der Merwe.
 N393/87—**Long**, Geoffrey Reginald, 4 Northumberland Place, Durban North, 4051, 16/9/87, Durban and Coast Local. Kenneth Thomas Guy.
 E203/87—**Regard**, Raymond Leo, c/o 21 Longhill Street, Queenstown, 5320. 17 September 1987. Eastern Cape. Bolze's Pharmacy CC.
 E202/87—**Botha**, Gerhardus Hermanus Stephanus, who resides at 25 Kipling Avenue, Kensington, Port Elizabeth. 9 September 1987, South Eastern Cape Local. Lucy May Combent.
 N371/87—**Wahed**, Abdul Rasheed, married in community of property to Fatima Rasheed Wahed, Flat 1, Randerees Building, 137 Brook Street, Durban. 9/9/87, Durban and Coast Local. Bashir Mahomed Rafik.
 N373/87—**Pickford**, Dennis John, of Pickford Estates, Shongweni, Natal. 14 September 1987, Natal Provincial. The Standard Bank of South Africa Ltd.
 N400/87—**Fouche**, John Peter, Mbabaat Rest Camp, Orpen Gate Road, District of Klaserie, Phalaborwa. 30/9/87, Natal Provincial. Roy Peter Fouche.
 T2768/87—**Strydom**, Adriaan Albertus, First Respondent, Elizabeth Francina Susanna Strydom, Second Respondent, an adult male married in community of property to the Second Respondent who presently resides at 89 Senator Road, 6 Villa Viconai, Wychwood, Germiston. 15 September 1987, Witwatersrand Local. Dawid Jan Jacobus Strydom.
 T2757/87—**Edelson**, Edel Judah, an adult male businessman who resides at Plot 6, Benoni Orchards, Benoni. 15 September 1987, Witwatersrand Local. The Legal Trust Corporation (Pty) Ltd.
 T2727/87 ASR 3—**Van Rooyen**, Martha Maria. 15/9/87, Transvaalse Provinsiale. Ludwig Diener Prokureurs.
 T2827/87—**Buitendag**, Jan Hendrik, an adult male divorcee who conducts business for his own account under the name or style of Johannesburg Bookkeeping Services of Shop 3, Fords Centre, Dudley Smith Street, Boksburg. 29 September 1987, Witwatersrand Local. Sandra Cynthia Buitendag.
 T2629/87—**Robpat Investments CC**, has its registered office situate at c/o D. C. Holdstock (an auditor) of First Floor, Wilson's Building, 46 President Street, Germiston. 8/9/87, Witwatersrand Local. Hector Hercules Reid.
 T2749/87—**Omnibus Transport Group Holdings (Pty) Ltd**, 5a Carol-Anne Lane, Morningside, Sandton. 22/9/87, Witwatersrand Local. *Ex parte*.

Vorm/Form J 29

EERSTE BYEENKOMSTE VAN SKULDEISERS, KONTRIBUANTE, LEDE OF SKULDBRIEFHOUDERS VAN GESEKWESTREERDE BOEDELS, MAATSKAPPYE IN LIKWIDASIE OF ONDER VOORLOPIGE GEREGETELIKE BESTUUR

Nademaal die boedels of maatskappye hieronder vermeld op las van die Hooggeregshof van Suid-Afrika gesekwestreer, gelikwieder of onder voorlopige geregetelike bestuur geplaas is, word hierby deur die Meesters van die Hooggeregshof ingevolge artikels 17 (4) en 40 (1) van die Insolvensiewet, 1936, artikels 119 (3), 125 (1) en 196bis (4) van die Maatskappywet, 1926, en artikels 356 (1), 364 (1) en 429 van die Maatskappywet, 1973, kennis gegee dat 'n eerste byeenkoms van skuldeisers, kontribuante, lede of skuldbriefhouders van genoemde boedels of maatskappye op die datums, ure en plekke hieronder vermeld, vir die bewys van vorderings teen die boedels of maatskappye, die verkiesing van kurators, likwidateurs of geregetelike bestuurders of vir die doeleindes bedoel in artikel 364 of 431 van Wet 61 van 1973, na gelang van die geval, gehou sal word.

Die besonderhede word verstrek in die volgorde: Nommer van boedel/maatskappy; naam en beskrywing van boedel/maatskappy; datum van die voorlopige en datum van die finale bevel, en afdeling van hof waardeur order gemaak is, en datum, uur en plek van byeenkoms.

In 'n plek waarin 'n kantoor van 'n Meester is, word die byeenkoms voor die Meester en op ander plekke voor die Landdros gehou.

FIRST MEETINGS OF CREDITORS, CONTRIBUTORIES, MEMBERS OR DEBENTURE-HOLDERS OF SEQUESTERED ESTATES, COMPANIES BEING WOUND-UP OR PLACED UNDER PROVISIONAL JUDICIAL MANAGEMENT

The estate and companies mentioned below having been placed under sequestration, being wound up or having been placed under provisional judicial management by order of the Supreme Court of South Africa, Masters of the Supreme Court hereby give notice, pursuant to sections 17 (4) and 40 (1) of the Insolvency Act, 1936, sections 119 (3), 125 (1) and 196bis (4) of the Companies Act, 1926, and sections 356 (1), 364 (1) and 429 of the Companies Act, 1973, that a first meeting of creditors, contributories, members or debenture-holders of the said estates or companies will be held on the dates and at the times and places mentioned below, for proof of claims against the estates or companies, the election of trustees, liquidators or judicial managers or for the purposes referred to in section 364 or 431 of Act 61 of 1973, as the case may be.

The particulars are given in the following order: Number of estate/company; name and description of estate/company; date of the provisional and date of the final order, and division of court by which order made, and date, hour and place of meeting.

Meetings in a place in which there is a Master's office, will be held before the Master; elsewhere they will be held before the Magistrate.

- T2545/87—**Snyman**, Johannes Albertus Wessels, Kleinfontein, Bethal. 25/8/87—15/9/87, Transvaalse Provinsiale. 30/10/87, 09h00, Bethal.
 T2356/87—**Eastern Mining and Hardware (Edms.) Bpk.**, Levensentrum, Mainstraat 13, Kinross. 15 September 1987—11 Augustus 1987, Transvaalse Provinsiale. 13 November 1987, 09h30, Evander.
 T2456/87—**Bezuidenhout**, Albertus Markus, Gedeelte 2 van die plaas Blinkwater, Potgietersrus. 18/8/87—15/9/87, Transvaalse Provinsiale. 29/10/87, 10h00, Potgietersrus.
 T2466/87—**Joubert**, Isak Bartolomeus, Bendorstraat 10, Uitbreiding 15, Tzaneen, 0850. 18 Augustus 1987—15 September 1987, Transvaalse Provinsiale. 26 Oktober 1987, 09h00, Tzaneen.
 T2536/87—**Van der Merwe**, Hendrik Lodewyk, 1 Leslie Road, Irene, Verwoerdburg. 25/8/87—15/9/87, Transvaal Provinsiale. 28/10/87, 10h00, Pretoria.

- T2476/87—**Pretorius**, Wynand Johannes en Isabel Pretorius, albei van Kockstraat 187, Potchefstroom, getroud binne gemeenskap van goedere. 18/8/87—15/9/87, Transvaalse Provinsiale. 28/10/87, 10h00, Potchefstroom.
- T2246/87—**Thinane**, Doris Dikeledi, an adult divorcee of full legal capacity who is employed by Gert Willem de Lange, trading as Incorporated Building Construction and Pentax Civil Engineers at Strand, 163 Arnold Street, Alorde Extension 2, Alberton, or residing at Mariston Hotel, Johannesburg. 5/8/87—18/9/87, Witwatersrand Local. 28/10/87, 09h00, Alberton.
- T2650/87—**Greeff**, Thomas Gerhardus, Plot 50, Rooikoppies, Rayton, Bronkhorstspuit. 1/9/87—15/9/87, Transvaalse Provinsiale. 29/10/87, 10h00, Bronkhorstspuit.
- T1460/87—**Du Plooy**, Willie Joseph, Denysschenlaan 187, Mountain View, Pretoria, geskei. 12/5/87—16/6/87, Transvaalse Provinsiale. 28/10/87, 10h00, Pretoria.
- T2504/87—**Le Roux**, Gustav, Harrisonstraat 60, Colbyn, Pretoria. 24 Augustus 1987—15 September 1987, Transvaalse Provinsiale. 28 Oktober 1987, 10h00, Pretoria.
- T2454/87—**Baker**, Thomas Victor, Delmas Hotel, Sarel Cilliers Street, Delmas. 18/8/87—15/9/87, Transvaal Provinsiale. 30/10/87, 09h00, Delmas.
- T2444/87—**Joubert**, Theunis Johannes, Markstraat 4, Bethal. Finale bevel: 15 September 1987, Transvaalse Provinsiale. 09h00, Bethal.
- T2344/87—**Botha**, Zacharias Bloemerus, Magazynstraat 60, Pietersburg. 4 Augustus 1987—15/9/87, Transvaalse Provinsiale. 30/10/87, 09h00, Pietersburg.
- T2664/87/ASR2—**Janse van Vuuren**, Dawid Frederik, Emus Erasmusstraat 290, Erasmusrand, Pretoria. 11/8/87—8/9/87, Transvaalse Provinsiale. 28/10/87, 10h00, Pretoria.
- T2450/87—**De Bruyn**, Jacobus Andreas, Skoolstraat 18, Sannieshof, 2760. 18 Augustus 1987—15 September 1987, Transvaalse Provinsiale. 30/10/87, 08h30, Delareyville.
- T2484/87—**De Witt**, Frederick Christoffel jnr., Plot 145, Nanescol, Vanderbijlpark. 19/8/87—15/9/87, Transvaalse Provinsiale. 30/10/87, 10h00, Vanderbijlpark.
- T2395/87—**Snyman**, Lucia, handeldrywende as Magnolia Bloemiste, Van Riebeeckweg 42, Potgietersrus. Finale bevel: 8 September 1987, Transvaalse Provinsiale. 29 Oktober 1987, 10h00, Potgietersrus.
- T1575/87—**Mahobe**, Zola Daniel, an adult male who resides at Moroka. 26/5/87—30/6/87, Witwatersrand Local. 27/10/87, 09h00, Johannesburg.
- T2165/87—**Van Molendorf**, De Lange, 'n meerderjarige Blanke man woonagtig te Amsterdamweg 56, Gerdview, Germiston. 21/7/87—25/8/87, Witwatersrandse Plaaslike. 30/10/87, 09h30, Germiston.
- T2475/87—**Potgieters**, Johannes Lodewicus Snr., Hertzogstraat 49, Ogies, 2230. 18 Augustus 1987, 15 September 1987, Transvaalse Provinsiale. 30/10/87, 10h00, Witbank.
- T2425/87—**Dinwar (Edms.) Bpk.**, Joubertstraat 16, Ermelo. 18 Augustus 1987—15/9/87, Transvaalse Provinsiale. 30/10/87, 09h30, Ermelo.
- T2465/87—**Hart**, Johan, Maraboestraat 32, Rooihuiskraal, Verwoerdburg. 18/8/87—15/9/87, Transvaalse Provinsiale. 28/10/87, 10h00, Pretoria.
- T2555/87—**Snyman**, Daniel Gerhardus, Kleinfontein, Bethal. 25/8/87—15/9/87, Transvaalse Provinsiale. 30/10/87, 09h00, Bethal.
- N333/87—**Graham**, Claude Herbert, 7 Umgeni View Road, Crestview, Natal. 14/8/87—8/9/87, Durban and Coast Local. 27/10/87, 09h00, Durban.
- B380/87—**Schultz**, Fritz Constant, Bruinjeslaagte, Odendaalsrus. 28 Augustus 1987—17 September 1987, Oranje-Vrystaatse Provinsiale. 2 November 1987, 10h00, Odendaalsrus.
- B375/87—**Stander**, Frederick Petrus, Voortrekkerstraat 24, Reitz. 27 Augustus 1987—17 September 1987, Oranje-Vrystaatse Provinsiale. 27 Oktober 1987, 10h00, Reitz.
- B370/87—**Smith**, Hermanus Lukas, Ibbotsonstraat 10, Fichardtspark, Bloemfontein. 27 Augustus 1987—17 September 1987, Oranje-Vrystaatse Provinsiale. 28 Oktober 1987, 10h00, Bloemfontein.
- N329/87—**Paul**, Stephen Anthony Watson, 4 Nice Drive, Uvongo, South Coast. 11/8/87—14/9/87, Durban and Coast Local. 29/10/87, 09h00, Port Shepstone.
- B195/87—**Van der Merwe**, Roelof Johannes, Mariondale, Ladybrand. 30/4/87—17/9/87, Oranje-Vrystaatse Provinsiale. 28/10/87, 11h00, Ladybrand.
- B371/87—**Walker**, Johannes Cornelius Jacobus, Fransstraat 61, Villiers. 27/8/87—17/9/87, Oranje-Vrystaatse Provinsiale. 27/10/87, 10h00, Frankfort.
- B373/87—**Eksteen**, Adriaan Bernardus, Carmelstraat 8, Bethlehem. 27/8/87—17/9/87, Oranje-Vrystaatse Provinsiale. 30/10/87, 09h30, Bethlehem.
- C534/87—**Gerber**, Stephanus Johannes, woonagtig te Markstraat 38, Parowvallei. 1 September 1987—22 September 1987, Kaap die Goeie Hoop Provinsiale. 27 Oktober 1987, 11h00, Bellville.
- C519/87—**Rolleston**, Patrick William, residing at 67 Ottery Road, Wynberg, Cape. 25/8/87—22/9/87, Cape of Good Hope Provinsiale. 29 Oktober 1987, 09h00, Wynberg.
- C474/87—**Theron**, Johannes Jacobus Blichnaug, woonagtig te Mullerstraat 2, Vredelust, Bellville. 29/7/87—18/9/87, Kaap die Goeie Hoop Provinsiale. 27/10/87, 11h00, Bellville.
- C533/87—**Carbon Dioxide Gas (Pty) Ltd**, registered office at Dante Uys & Company, Saambou Building, 14 Kristal Avenue, Bellville. 28 Augustus 1987—18 September 1987, Cape of Good Hope Provinsiale. 27 Oktober 1987, 11h00, Bellville.
- C503/87—**Bresler**, Frans Rynhardt, Uitkom, Moorreesburg. 14/8/87—11/9/87, Kaap die Goeie Hoop Provinsiale. 30 Oktober 1987, 10h00, Moorreesburg.
- C513/87—**Erasmus**, Johannes Jacobus Harmse, residing at 84 Ryno Kriel Avenue, Universitas, Bloemfontein. 21/8/87—11/9/87, Cape of Good Hope Provinsiale. 28 Oktober 1987, 10h00, Bloemfontein.
- C521/87—**Tang**, Steven John, residing at 4 Wessels Road, Kenilworth. 25/8/87—15/9/87, Cape of Good Hope Provinsiale. 29/10/87, 09h00, Wynberg.
- C509/87—**Promax (Cape) (Pty) Ltd**, registered office at Deloitte Haskins and Sells, 35 Wale Street, Cape Town. 21/8/87—11/9/87, Cape of Good Hope Provinsiale. 30 Oktober 1987, 09h00, Cape Town.
- K70/87—**Janse van Rensburg**, Elmarie, woonagtig te Markstraat 29, Upington. 21 Augustus 1987—25 September 1987, Noord-Kaapse. 30 Oktober 1987, 09h30, Upington.
- K71/87—**Scholtz**, Lourens Marthinus, p/a Transkaroo Inn, Drie Susters, distrik Victoria-Wes. 21 Augustus 1987—25 September 1987, Noord-Kaapse. 3 November 1987, 14h00, Victoria-Wes.
- K64/87—**Liebenberg**, Petrus Louis, woonagtig te Korhaansingel 29, Hartswater. 31 Julie 1987—25 September 1987, Noord-Kaapse. 29 Oktober 1987, 09h00, Hartswater.
- K69/87—**Janse van Rensburg**, Daniel Jacobus, woonagtig te Markstraat 29, Upington. 21 Augustus 1987—25 September 1987, Noord-Kaapse. 30 Oktober 1987, 09h30, Upington.
- K77/87—**Van Staden**, Hendrik Petrus, p/a Evkom, Barkley-Wes. 28 Augustus 1987—25 September 1987, Noord-Kaapse. 4 November 1987, 09h00, Barkly-Wes.
- K79/87—**Vermeulen**, Wynand Johannes, 'n boer woonagtig te President Steynstraat, Stella. 28 Augustus 1987—25 September 1987, Noord-Kaapse. 2 November 1987, 09h00, Vryburg.
- E813/87—**May**, Errol, 4 Southey Street, Adcockvale, Port Elizabeth. 6000. 19 Augustus 1987—9 September 1987, South Eastern Cape Local. 28 Oktober 1987, 14h00, Port Elizabeth.
- E179/87—**Deeltjefs**, Willem Adriaan Andreas, residing at 26 Salie Street, Jeffreysbay. 19 Augustus 1987—9 September 1987, South Eastern Cape Local. 28 Oktober 1987, 10h00, Humansdorp.

- E178/87—**Wilson**, Colin John, who trades as St. George's Mini Mart Cafe, 18 King George Street, St George's Strand, Port Elizabeth, 19 August 1987—9 September 1987. South Eastern Cape Local. 28 October 1987, 14h00, Port Elizabeth.
- E153/87—**Education and Management Corporation (Pty) Ltd**, c/o Coopers and Lybrand Trust, Abacus House, 29 Western Road, Port Elizabeth, 6000. 23 July 1987—17 September 1987. Eastern Cape. 28 October 1987, 14h00, Port Elizabeth.
- E126/87—**Rice**, Clinton Frederick de Neuilly, residing at Selibe Pikwe, Botswana. 18/6/87—17/9/87, Eastern Cape. 30/10/87, 10h00, Cradock.
- N321/87—**Bomado (Pty) Ltd**, Empress Hotel, 211 Marine Parade, Durban. 14/8/87—11/9/87, Durban and Coast Local. 27/10/87, 09h00, Durban.
- N319/87—**Nel**, Paul Martens, van die plaas Dorinbos, distrik Magudu, Natal. 13/8/87—17/9/87, Natalse Provinsiale. 29/10/87, 10h00, Ngotsi.
- T731/87—**Stella**, Nicola, an adult male divorcee, and residing at 7 Drakenstein, Heyneke Road, Sunset Acres, Johannesburg. 3/3/87—28/4/87, Witwatersrand Local. 27/10/87, 09h00, Johannesburg.
- T1213/87—**Fick**, Christiaan Kleinhans, Neavestraat 8, Breyten. 7/4/87—9/6/87, Transvaalse Provinsiale. 27/10/87, 10h00, Breyten.
- T1832/87—**Ismail**, Ahmed, an adult male businessman who is resident and/or carries on business at one or more of the following addresses: 165 Main Road, Kliptown, Johannesburg, 96 Rose Street, Lenasia, Johannesburg, Shops 9 and/or 11, and/or 12 Jamila Centre, 916 Silver Street, Eldorado-park, Johannesburg, 3 Yster Crescent, Eldoradopark, Johannesburg. 28 July 1987—15 September 1987, Witwatersrand Local. 27 October 1987, 09h00, Johannesburg.
- T2421/87—**Little Bazaar (Pty) Ltd**, carrying on business as a Ladies' Boutique under the name and style of Du Barry at 85b Kotze Street, Hillbrow, Johannesburg. 13 August 1987—15 September 1987, Witwatersrand Local. 27 October 1987, 09h00, Johannesburg.
- T2312/87—**Neuhoff & Smith (Pty) Ltd**, c/o Jaco de Wet & Company, Agatha Street, Tzaneen. 11/8/87—22/9/87, Transvaal Provincial. 2 November 1987, 09h00, Tzaneen.
- T2462/87—**Ermelo Huisdienste en Bouers (Pty) Ltd**, Janloy Building, 20 De Jager Street, Ermelo. 18/8/87—22/9/87, Transvaal Provincial. 30/10/87, 09h30, Ermelo.
- T2169/87—**Theofrastos**, Nicolaos Raymond, an adult male residing at 56 Second Avenue, Bezuidenhouts Valley, Johannesburg. 21/7/87—18/8/87, Witwatersrand Local. 29/10/87, 09h00, Johannesburg.
- T2539/87—**Oosthuizen**, Marius Magiel en Johanna Elizabeth Oosthuizen, albei woonagtig te Premierstraat 6, Olifantsfontein en getroud binne gemeenskap van goedere met mekaar. 25 Augustus 1987—22 September 1987, Transvaalse Provinsiale. 26 Oktober 1987, 10h00, Pretoria.
- T2779/87—**Franco Vago (Cape) (Pty) Ltd**, having its principal place of business at Ninth Floor, Hunts Corner, Eloff Street, Johannesburg. Final order: 15/9/87, Witwatersrand Local. 29/10/87, 09h00, Johannesburg.
- T2308/87—**Janse van Rensburg**, Willem Frederik Klopper, van die plaas Nooitgedacht, Bronkhorstspuit. 12/8/87—22/9/87, Transvaalse Provinsiale. 29 Oktober 1987, 10h00, Bronkhorstspuit.
- T2478/87—**Retief**, Eugene, Eerste Respondent van die plaas Rietfontein, Koedoeskop, Thabazimbi en Hendrika Magdalena Retief, Tweede Respondent, van dieselfde adres en getroud binne gemeenskap van goedere met die Eerste Respondent. 18/8/87—15/9/87, Transvaalse Provinsiale. 30/10/87, 10h00, Thabazimbi.
- T2668/87 **ASR 3—Azon (Pty) Ltd**, c/o David Myers & Co., 330 Pasteur Chambers, 191 Jeppe Street, Johannesburg. Final order: 2/9/87, Witwatersrandse Plaaslike. 27/10/87, 09h00, Johannesburg.
- T1897/87—**P.O.P. Developments (Pty) Ltd**, formally carrying on business as cabinet makers with its registered head office at 8 O'Reilly Road, Berea, Johannesburg. 23/6/87—14/7/87, Witwatersrand Local. 29/10/87, 09h00, Johannesburg.
- T2219/87—**Dicks**, Bernard Randell, Amarandstraat 189, Waterkloof Glen-uitbreiding 2, Pretoria. 28/7/87—22/9/87, Transvaalse Provinsiale. 26/10/87, 10h00, Pretoria.
- T2388/87—**Senekal**, Michael Coenraad Cornelius, Pongolajaan 207, Sinoville, Pretoria. 11 Augustus 1987—8 September 1987, Transvaalse Provinsiale. 30/10/87, 10h00, Pretoria.
- T2548/87—**Theunissen**, Servaas Daniël, Christiaan Mullerhof 35, Springbokweg, Voortrekkerweg. 25/8/87—22/9/87, Transvaalse Provinsiale. 30/10/87, 10h00, Pretoria.
- T2778/87—**Franco Vago & Company (Pty) Ltd**, having its principal place of business at Ninth Floor, Hunts Corner, 20 New Street, Johannesburg South. Final order: 15 September 1987, Witwatersrand Local. 27 October 1987, 09h00, Johannesburg.
- T2777/87—**Africargo (Pty) Ltd**, formerly carried on business as freight forwarding and shipping agents and which had its principal place of business at Ninth Floor, Hunts Corner, 20 New Street, Johannesburg South. Final order: 15/9/87, Witwatersrand Local. 27/10/87, 09h00, Johannesburg.
- T2357/87—**Fawell**, John Archibald, Gedeelte 42 van die plaas Zuurplaat, Rustenburg. 4 Augustus 1987—8 September 1987, Transvaalse Provinsiale. 28 Oktober 1987, 08h30, Rustenburg.
- T2347/87—**Bath**, Timothy William Bruce, 'n direkteur van CPM Projekte (Edms.) Bpk., Netro Fordgebou, Ou Pretoriaweg 2, Nelspruit. 11/8/87—22/9/87, Transvaalse Provinsiale. 30/10/87, 09h00, Nelspruit.
- T2409/87—**World Commodity Sales (Pty) Ltd**, having its registered address at 459 Industry Road, Clayville, Olifantsfontein. 11 August 1987—15 September 1987, Witwatersrand Local. 30/10/87, 10h00.
- T2377/87—**Mouton**, Johan Brian, I.D. 5108235119001, Glenstraat 173, Weavind Park, Pretoria. 4/8/87—1/9/87, Transvaalse Provinsiale. 30/10/87, 10h00, Pretoria.
- T2517/87—**Van Niewenhuizen**, Gertruida Margrietha Elizabeth N.O., in haar hoedanigheid as Eksekutriese in die boedel van wyle Wynand Jacobus Janse van Niewenhuizen, Adelhofwoonstelle 28, Jan van Riebeeckstraat, Middelburg, Transvaal. Finale bevel: 3/9/87, Transvaalse Provinsiale. 28/10/87, 10h00, Middelburg.
- T2339/87—**Bothma**, Deon Frederick, woonagtig binne die regsgebied van bogemelde agbare hof en wel te Salviastraat 43, Roodekrans, Roodepoort, getroud binne gemeenskap van goedere op 28 November 1975 met Louise Bothma. Finale bevel: 15/9/87, Witwatersrandse Plaaslike. 28/10/87, 09h00, Roodepoort.
- T1479/87—**Exquisite Import & Export CC**, 101 Misa Centre, Fir Drive, Northcliff, Johannesburg. 12/5/87—23/6/87, Witwatersrand Local. 3/11/87, 09h00, Johannesburg.

Vorm/Form 1

AANSTELLING VAN KURATORS EN LIKWIDATEURS EN BEWYS VAN VORDERINGS IN GESEKWESTREERDE BOEDELS OF MAATSKAPPYE IN LIKWIDASIE

Ingevolge artikels 40 (3), 56 (3) en 77 van die Insolvensiewet, 1936, artikels 129, 179 en 182 van die Maatskappywet, 1926, en artikels 339, 366, 375 (5) (b) en 402 van die Maatskappywet, 1973, word hierby kennis gegee dat die persone hieronder vermeld as kurators of likwidateurs aangestel is, na gelang van die geval, en dat persone wat enigiets aan die boedels of maatskappye verskuldig is die skulde, tensy anders vermeld, onmiddellik by genoemde kurators of likwidateurs moet betaal.

Byeenkomste van skuldeisers of kontribuante van genoemde boedels of maatskappye sal gehou word op die datums, ure en plekke hieronder vermeld vir die bewys van vorderings teen die boedels of maatskappye, vir die ontvangs van die verslae van die kurators of likwidateurs oor die sake en toestand van die boedels of maatskappye, en om opdragte aan die kurators of likwidateurs uit te reik betreffende die verkoop of opvordering van gedeeltes van die boedels of bates van die maatskappye of betreffende aangeleenthede rakende die beheer daarvan.

Die besonderhede word verstrek in die volgorde: Nommer van boedel/maatskappy; naam en beskrywing van boedel/maatskappy; naam en adres van kurator of likwidateur, en datum, uur en plek van byeenkoms en tydperk waarin skuld betaal moet word, indien dit nie onmiddellik moet geskied nie.

In 'n plek waarin 'n kantoor van 'n Meester is, word die byeenkoms voor die Meester en op ander plekke voor die Landdros gehou.

APPOINTMENT OF TRUSTEES AND LIQUIDATORS AND PROOF OF CLAIMS IN SEQUESTERED ESTATES OR COMPANIES BEING WOUND UP

Pursuant to sections 40 (3), 56 (3) and 77 of the Insolvency Act, 1936, sections 129, 179 and 182 of the Companies Act, 1926, and sections 339, 366, 375 (5) (b) and 402 of the Companies Act, 1973, notice is hereby given that the persons mentioned below have been appointed trustees or liquidators, as the case may be, and that the persons indebted to the estates or companies are required to pay their debts to them forthwith unless otherwise indicated.

Meetings of creditors or contributories of the said estates or companies will be held on the dates and at the times and places mentioned below, for proof of claims against the estates or companies, for the purpose of receiving the trustees' or liquidators' reports as to the affairs and conditions of the estates or companies and for giving the trustees or liquidators directions concerning the sale or recovery of any parts of the estates or assets of the companies or concerning any matter relating to the administration thereof.

The particulars are given in the following order: Number of estate/company; name and description of estate/company; name and address of trustee or liquidator and date, hour and place of meeting and period within which debt must be paid, if this is not to be done forthwith.

Meetings in a place in which there is a Master's Office, will be held before the Master; elsewhere they will be held before the Magistrate.

T764/87—**Van Zijl**, Schultze, Lund & Tredoux (Pty) Ltd, in liquidation; E. M. Singer and B. G. S. de Wet, P.O. Box 9460, Johannesburg, 2000. 5/11/87, 09h00, Johannesburg.

T4133/86—**Van der Westhuizen**, Cornelius Johannes and Iris Sharon Rose van der Westhuizen; Farrell Wainer, P.O. Box 9460, Johannesburg, 2000. 3/11/87, 09h00, Johannesburg.

T1204/87—**Jooste**, Jacobus Albertus; Neville John Jessop, P.O. Box 9460, Johannesburg, 2000. 5/11/87, 09h00, Randfontein.

T2162/87—**Goddard**, Frederick Michael Daniël Austin; W. Hogewind, P.O. Box 5123, Horison. 1730. 6/11/87, 09h30, Germiston.

T1292/87—**Van Greune**, A. P. C.; J. L. Viljoen, Wetskrag Trust, Posbus 4638, Pretoria. 30 Oktober 1987, 10h00, Pretoria. Tweede vergadering.

T680/87—**Du Plooy**, Nico; J. L. Viljoen, Wetskrag Trust, Posbus 4638, Pretoria. 30 Oktober 1987, 10h00, Pretoria. Tweede vergadering.

T268/87—**Prinsloo**, Hendrik; J. L. Viljoen, Wetskrag Trust, Posbus 4638, Pretoria. 30 Oktober 1987, 10h00, Pretoria. Tweede vergadering.

T1091/87—**Berrange**, W. C. J. Jr.; J. L. Viljoen, Wetskrag Trust, Posbus 4638, Pretoria. 30 Oktober 1987, 10h00, Pretoria. Tweede vergadering.

N279/87—**Seychelles Investment Company (Pty) Ltd**, in voluntary liquidation; Alan Leigh Norman, P.O. Box 76, Pietermaritzburg, 3200.

T675/87—**Nienaber**, Susanna Helena Maria; V. A. van Diggelen, for Limvaal Trustees, P.O. Box 3548, Pretoria. 30 October 1987, 9.30 a.m., Witbank.

T116/87—**Van Dalen**, Thomas; V. A. van Diggelen, for Limvaal Trustees, P.O. Box 3548, Pretoria. 4 November 1987, 11.00 a.m., Heidelberg.

T1519/87—**Laeveld Kassies (Edms.) Bpk.**, in liquidation; V. A. van Diggelen, for Limvaal Trustees, P.O. Box 3548, Pretoria. 2 November 1987, 9.00 a.m., Tzaneen.

T1512/87—**J & B Books (RSA) (Pty) Ltd**, in liquidation; J. F. Klopper, for Syfrets Trust Ltd, P.O. Box 29980, Pretoria. 2 November 1987, 10h00, Pretoria.

C169/87—**Vorster**, Robin Basil, Id. No. 4906115004008; M. J. Lane and M. T. East, for Coopers & Lybrand Trust (Pty) Ltd, 10th Floor, Shell House, 9 Riebeeck Street, Cape Town. 3 November 1987, 11 a.m., Bellville.

C176/87—**Radsma**, Bote Cornelius, Id. No. 4810265144103; M. J. Lane and M. T. East, for Coopers & Lybrand Trust (Pty) Ltd, 10th Floor, Shell House, 9 Riebeeck Street, Cape Town. 3 November 1987, 11 a.m., Bellville.

C179/87—**Maintain-A-Pool (Partnership)**; M. J. Lane and M. T. East, for Coopers & Lybrand Trust (Pty) Ltd, 10th Floor, Shell House, 9 Riebeeck Street, Cape Town. 3 November 1987, 11 a.m., Bellville.

C406/87—**Marsh**, Desmond Stephen, Id. No. 022890880, born 25/3/46. M. J. Lane and M. T. East, for Coopers & Lybrand Trust (Pty) Ltd, 10th Floor, Shell House, 9 Riebeeck Street, Cape Town, 8001. 5 November 1987, 9 a.m., Wynberg.

B285/87—**Pelsler**, Christoffel Bernardus, voorheen van Josiasstraat 100, Odendaalsrus; Jan Lodewikus Pretorius. 2 November 1987, 10h00, Odendaalsrus.

N480/86—**Hamilton**, Voden Frank, formerly trading as BT Agencies; J. A. Bruce and C. J. Catterall, c/o Metboard (Natal) Ltd, Fourth Floor, Federated Insurance House, 320 Smith Street, 4001. 3 November 1987, 09h00, Durban.

K39/87—**Van Romburgh**, Johannes Nicolaas; David Jacobus Cilliers, Posbus 12, Hartswater. 22 Oktober 1987, 10h00, Warrenton.

T1678/87—**Buys**, Aletta Maria; Theo Tromp, c/o Central Trust CC, P.O. Box 6126, Johannesburg, 2000. 11 November 1987, 09h00, Roodepoort.

T1255/87—**Olivier**, Willem Andries Stephanus, Palmparkwoonstelle 41, Bethal; N. H. Boezaart, p/a Haasbroek & Boezaart, Posbus 2205, Pretoria. 6 November 1987, 09h00, Bethal.

T1078/87—**Olivier**, Elizabeth Maria, Palmparkwoonstelle 41, Bethal; N. H. Boezaart, p/a Haasbroek & Boezaart, Posbus 2205, Pretoria. 6 November 1987, 09h00, Bethal.

C748/86—**Kruger**, Johan, a former director of the Octopus Group of Companies; P. P. Tredoux, for Syfrets Trust Ltd, 140 St George's Street, Cape Town. 27 October 1987, 11h00, Bellville.

C267/87—**Marais**, Peter Noel, trading as Willies Service Station, Id. No. 2812185030000; M. T. East, for Coopers & Lybrand Trust (Pty) Ltd, 10th Floor, Shell House, 9 Riebeeck Street, Cape Town. 29/10/87, 9 a.m., Wynberg.

C377/87—**De Jongh**, Jacobus Adriaan Louw, Id. No. 4205175074005; P. P. Tredoux, for Syfrets Trust Ltd, 140 St George's Street, Cape Town. 30 October 1987, 10h00, Riversdal.

E120/87—**Pugh**, John Anthony, formerly trading as BJP Communications and residing at 49 Spruce Road, Colleen Glen, Port Elizabeth; Stephen Henry Levin, for East Cape Trustees CC, AA House, 4 Rink Street, Port Elizabeth, 6001. 11/11/87, 14h00, Port Elizabeth.

E131/87—**Steffens**, Andre, formerly residing at Moreson, St Albans, Port Elizabeth; Stephen Henry Levin, for East Cape Trustees CC, AA House, 4 Rink Street, Port Elizabeth, 6001. 25/11/87, 14h00, Port Elizabeth.

B268/87—**Oosthuizen**, Leon; Dr. C. Cilliers, p/a Webbers, Posbus 501, Bloemfontein. 28 Oktober 1987, 10h00, Bloemfontein.

N210/87—**Natal Sales Control Systems (Pty) Ltd**, in liquidation; G. T. Graham, P.O. Box 1858, Durban. 27 October 1987, 09h00, Durban. Second meeting of Creditors.

- B155/87—**Van der Merwe, Adriaan Jacobus**; B. St C. Cooper en S. Tsangarakis, p/a E. G. Cooper & Seuns, Posbus 27, Bloemfontein, 9300. 28 Oktober 1987, 10h00, Welkom.
- C392/87—**Rustland (Edms.) Bpk.**, in likwidasie, handeldrywende as Fair Deal Superette, De Vriesstraat, Beaufort-Wes; P. G. van Velden, Donkinstraat 36, Posbus 25, Beaufort-Wes. 5 November 1987, 09h00, Beaufort-Wes.
- E93/87—**Olekens, Frederik Johannes**; Basil Kenneth Spengler van Zyl and Hermanus Maritz; for Syfrets Trust Ltd, 94 Main Street, Port Elizabeth, 6001. 28 October 1987, 2.00 p.m., Port Elizabeth.
- E200/86—**Browne, Cecil Eric**; Basil Kenneth Spengler van Zyl and Hermanus Maritz, for Syfrets Trust Ltd, 94 Main Street, Port Elizabeth, 6001. 28 October 1987, 2.00 p.m., Port Elizabeth.
- E442/86—**Whitehead, Victor Edmund**; Basil Kenneth Spengler van Zyl and Hermanus Maritz, for Syfrets Trust Ltd, 94 Main Street, Port Elizabeth, 6001. 28 October 1987, 2.00 p.m., Port Elizabeth.
- T2046/87—**MS Tiling and Building Contractors (Pty) Ltd**, in liquidation; Theo Tromp, c/o Central Trust CC, Third Floor, EP Building, 112 Commissioner Street, Johannesburg, 2000. 29 October 1987, 09h00, Johannesburg.
- C432/87—**September, Mogamat Tape**; Montagu Philip Plant, 4 Wale Street, Cape Town, P.O. Box 86, Cape Town, 8000. 28/9/87, Cape Town.
- Pemary (Pty) Ltd**, in voluntary winding-up; David William Dunn MacDonald, 11th Floor, Regis House, 126 Adderley Street, Cape Town.
- N69/87—**Nair, V. M.**; Mark William Lynn, c/o E. R. Browne Incorp., P.O. Box 346, Pietermaritzburg. 29 October 1987, 10.00 a.m., Stanger.
- T2223/87—**Potgieter, Stephen**; Sybrand Slot, p/a Klein-Slot Trustees, Posbus 5437, Pretoria, 0001. 2/11/87, 10h00, Pretoria.
- B88/87—**Anne Strauss Beleggings (Edms.) Bpk.**, in vrywillige likwidasie deur lede; C. S. H. Bobbert, St Andrewstraat 151, Bloemfontein.
- E60/87—**Rice, Marc Eduard de Neuilly**, residing at 43 Breë Street, Cradock, Cape Province; Andrew Stuart Paterson and Kenneth Norman Paterson, Third floor, CNA Building, 37 Union Street, East London. 30 October 1987, 10 a.m., Cradock.
- E148/87—**Michau, Christoffel Andreas**, residing at 16 J. G. Strydom Street, Cradock; Andrew Stuart Paterson and Kenneth Norman Paterson, Third Floor, CNA Building, 37 Union Street, East London. 30 October 1987, 10 a.m., Cradock.
- C218/87—**Verney, Richard James**; Renate Helene Dorothea Ingram Trustee, c/o The Board of Executors Trustees (Pty) Ltd, 4 Wale Street, Cape Town. 30 October 1987, 9.00 a.m., Cape Town.
- T1625/87—**Du Plessis, Christiaan Rudolph De Wet**; P. A. Cronjé, P.O. Box 17300, Pretoria North. 28/10/87, 10h00, Pretoria.
- T75/87—**President Radio Distributors**; W. T. J. Moolman, c/o Ernst & Whinney Trust & Corporate Services (Pty) Ltd, P.O. Box 2322, Johannesburg, 2000. 09h00, Alberton.
- T3304/86—**Albag Properties**; W. T. J. Moolman, c/o Ernst & Whinney Trust & Corporate Services (Pty) Ltd, P.O. Box 2322, Johannesburg, 2000. 09h00, Johannesburg.
- T1666/87—**Data Construction (Pty) Ltd**; W. T. J. Moolman, c/o Ernst & Whinney Trust & Corporate Services (Pty) Ltd, P.O. Box 2322, Johannesburg, 2000. 27 October 1987, 09h00, Johannesburg.
- T834/87—**Bronley Properties (Pty) Ltd**, in voluntary liquidation; R. J. Miller, P.O. Box 1370, Johannesburg, 2000.
- T4790/86—**Alex Panelbeaters (Pty) Ltd**, in liquidation; C. G. Foot, c/o Metrtrust Ltd, P.O. Box 32225, Braamfontein, 2017. 30/10/87, 10h00, Springs.
- T1344/87—**French, John William and Lillias Annette French**; Philip David Berman, c/o Albert Ruskin Trust Board, P.O. Box 7976, Johannesburg, 2000. 29 October 1987, 11.30 a.m., Boksburg.
- T408/87—**Schultz, Clive Norman**; P. D. Berman, c/o Albert Ruskin Trust Board, P.O. Box 7976, Johannesburg, 2000. 5 November 1987, 11.30 a.m., Boksburg.
- T1055/87—**Gschwend, Melvin**; P. D. Berman, c/o Albert Ruskin Trust Board, P.O. Box 7976, Johannesburg, 2000. 10 November 1987, 09.00 a.m., Johannesburg.
- T82/87—**Watson, M. S.**; P. D. Berman, c/o Albert Ruskin Trust Board, P.O. Box 7976, Johannesburg, 2000. 5 November 1987, 11.30 a.m., Boksburg.
- T1073/87—**Erf 77 St Andrews (Pty) Ltd**, in liquidation; Philip David Berman, J. R. Galloway & L. Cohen, c/o Albert Ruskin Trust Board, P.O. Box 7976, Johannesburg, 2000. 6 November 1987, 9.30 a.m., Germiston.
- T1074/87—**Erf 78 St Andrews (Pty) Ltd**, in liquidation; Philip David Berman, J. R. Galloway & L. Cohen, c/o Albert Ruskin Trust Board, P.O. Box 7976, Johannesburg, 2000. 6 November 1987, 9.30 a.m., Germiston.
- T1580/87—**Claesen, Cornelius Johannes and Margo Maria Glenis Claesen**; Philip David Berman, c/o Albert Ruskin Trust Board, P.O. Box 7976, Johannesburg, 2000. 12 November 1987, 09.00 a.m., Johannesburg.
- T1631/87—**Barstead, John Francis and Isabella Margerita Barstead**; P. D. Berman, c/o Albert Ruskin Trust Board, P.O. Box 7976, Johannesburg, 2000. 5 November 1987, 11.30 a.m., Boksburg.
- T487/87—**Venter, Robert Rolfe**; Philip David Berman, c/o Albert Ruskin Trust Board, P.O. Box 7976, Johannesburg, 2000. 4 November 1987, 10.00 a.m., Benoni.
- T1801/87—**Lovodis (Pty) Ltd**, in liquidation; Philip David Berman, c/o Albert Ruskin Trust Board, P.O. Box 7976, Johannesburg, 2000. 13 November 1987, 9.30 a.m., Witbank.
- T4363/86—**De Wet, Friedrich Wille and Louise Henrietta de Wet**; Philip David Berman, c/o Albert Ruskin Trust Board, P.O. box 7976, Johannesburg, 2000. 6 November 1987, 9.30 a.m., Delmas.
- T4764/86—**Delta Catering Equipment CC**, in liquidation; P. D. Berman, c/o Albert Ruskin Trust Board, P.O. Box 7976, Johannesburg 2000. 5 November 1987, 9.00 a.m., Johannesburg.
- T802/87—**Court Lady Investments (Pty) Ltd**, in liquidation; P. D. Berman, J. R. Galloway & L. Cohen, c/o Albert Ruskin Trust Board, P.O. Box 7976, Johannesburg, 2000. 12 November 1987, 9.00 a.m., Johannesburg.
- T1075/87—**Marlouw Properties (Pty) Ltd**, in liquidation; P. D. Berman, L. Cohen & J. R. Galloway, c/o Albert Ruskin Trust Board, P.O. Box 7976, Johannesburg, 2000. 3 November 1987, 09.00 a.m., Johannesburg.
- T4259/86—**Conlargo Investments (Pty) Ltd**; J. M. Oelofsen, c/o P.O. Box 2186, Johannesburg, 2000. 6/11/87, 09h00, Krugersdorp.
- T703/86—**Saharin, M.**, and D. J. Tunmer, formerly trading as Interarms Arcadia; M. K. Hyslop, c/o P.O. Box 2186, Johannesburg, 2000. 3/11/87, 09h00, Johannesburg.
- C349/87—**Guzgay, Ebrahim Cassiem**, trading as Camberwell Supply Store; Brian W. Smith, c/o Cape Trustees Ltd, 18th Floor, 2 Long Street, Cape Town, 8001. 29/10/87, 09.00 a.m., Wynberg.
- E243/86—**Gate Properties (Pty) Ltd**, in liquidation; D. J. Klerck & K. N. Paterson, Joint Liquidators, c/o Coopers & Lybrand Trust (Pty) Ltd, P.O. Box 1235, Port Elizabeth, 6000. 28 October 1987, 2.00 p.m., Port Elizabeth.
- E238-86—**Linerk Investments (Pty) Ltd**, in liquidation; D. J. Klerck & K. N. Paterson, Joint Liquidators, c/o Coopers & Lybrand Trust (Pty) Ltd, P.O. Box 1235, Port Elizabeth, 6000. 28 October 1987, 2.00 p.m., Port Elizabeth.
- E239/86—**Mater Enterprises (Pty) Ltd**, in liquidation; D. J. Klerck & K. N. Paterson, Joint Liquidators, c/o Coopers & Lybrand Trust (Pty) Ltd, P.O. Box 1235, Port Elizabeth, 6000. 28 October 1987, 2.00 p.m., Port Elizabeth.
- E240/86—**Mervyndale Estates (Pty) Ltd**, in liquidation; D. J. Klerck & K. N. Paterson, Joint Liquidators, c/o Coopers & Lybrand Trust (Pty) Ltd, P.O. Box 1235, Port Elizabeth, 6000. 28 October 1987, 2.00 p.m., Port Elizabeth.
- E241/86—**Redlin Investments (Pty) Ltd**, in liquidation; D. J. Klerck & K. N. Paterson, Joint Liquidators, c/o Coopers & Lybrand Trust (Pty) Ltd, P.O. Box 1235, Port Elizabeth, 6000. 28 October 1987, 2.00 p.m., Port Elizabeth.
- E242/86—**Tanel (Pty) Ltd**, in liquidation; D. J. Klerck & K. N. Paterson, Joint Liquidators, c/o Coopers & Lybrand Trust (Pty) Ltd, P.O. Box 1235, Port Elizabeth, 6000. 28 October 1987, 2.00 p.m., Port Elizabeth.
- E244/86—**Eureka Estates (Pty) Ltd**, in liquidation; D. J. Klerck & K. N. Paterson, Joint Liquidators, c/o Coopers & Lybrand Trust (Pty) Ltd, P.O. Box 1235, Port Elizabeth, 6000. 28 October 1987, 2.00 p.m., Port Elizabeth.

- E245/86—**Basko Properties (Pty) Ltd**, in liquidation; D. J. Klerck & K. N. Paterson, Joint Liquidators, c/o Coopers & Lybrand Trust (Pty) Ltd, P.O. Box 1235, Port Elizabeth, 6000. 28 October 1987, 2.00 p.m., Port Elizabeth.
- E246/86—**Afrisher Investments (Pty) Limited**, in liquidation; D. J. Klerck & K. N. Paterson, Joint Liquidators, c/o Coopers & Lybrand Trust (Pty) Ltd, P.O. Box 1235, Port Elizabeth, 6000. 28 October 1987, 2.00 p.m., Port Elizabeth.
- T1232/87—**Robin Marter & Co (Pty) Ltd**; I. Bekker, c/o Deloitte Haskins and Sells Trust (Pty) Ltd, P.O. Box 1009, Johannesburg, 2000. 10/11/87, 09h00, Johannesburg.
- E61/87—**Crouse**, Andries Francois and Rosalina Crouse, who reside at 22 Metcalf Road, Cradock; Andrew Stuart Paterson and Kenneth Norman Paterson, Third Floor, CNA Building, 37 Union Street, East London. 30 October 1987, 10.00 a.m., Cradock.
- E147/87—**Everitt**, Gavin Eugene, who formerly carried on business as Gee Sales, at First Floor, Brands Building, corner of Oxford Street and Stephenson Streets, East London; Andrew Stuart Paterson, Kenneth Norman Paterson, Third Floor, CNA Building, 37 Union Street, East London. 6 November 1987, 10.00 a.m., East London.
- T1775/87—**Schneider**, Anthony Morris; Mervyn I. Swartz, c/o Rand Board of Trustees, P.O. Box 308, Johannesburg, 2000. 3 November 1987, 9.00 a.m., Johannesburg.
- T1657/87—**Wynand Strydom Racing (Pty) Ltd**, in liquidation; Mervyn I. Swartz, c/o Rand Board of Trustees, P.O. Box 308, Johannesburg, 2000. 3 November 1987, 09.00 a.m., Johannesburg.
- T2088/87—**Edwardes-Evans**, James; Mervyn I. Swartz, c/o Rand Board of Trustees, P.O. Box 308, Johannesburg, 2000. 5 November 1987, 9.00 a.m., Johannesburg.
- T1736/87—**MBW Projects (Pty) Ltd**, in liquidation; Mervyn I. Swartz, c/o Rand Board of Trustees, P.O. Box 308, Johannesburg, 2000. 4 November 1987, 10.00 a.m., Benoni.
- T1675/87—**Dinino**, Bruno Angelo Nicolo, Mervyn I. Swartz, c/o Rand Board of Trustees, P.O. Box 308, Johannesburg, 2000. 3 November 1987, 9.00 a.m., Johannesburg.
- T540/87—**Tommy du Plessis Sport (Pty) Ltd**, in liquidation; B. B. Nel, 527 Prudential Assurance Building, 28 Church Square, Pretoria. 2/11/87, 10h00, Pretoria.
- T1387/87—**Theron**, Johannes Lukas, Id. No. 4011205042009, voorheen handelendrywende as Kiepersol Elektries; J. N. Bekker, p/a Nicolaas Bekker Trustees, Posbus 8550, Pretoria, 0001, Tel: 83-5015 en 803-8151. 6 November 1987, 09h00, Nelspruit.
- B740/86—**Dawid Welgemoed Slaghuis BK**, in likwidasie; F. R. R. Neethling Naudes, Posbus 153, Bloemfontein. 28/10/87, 10.00 v.m., Theunissen, eerste byeenkoms.
- T172/87—**Dagbreek Landbou Agentskappe CC**, in liquidation; B. B. Nel, 527 Prudential Assurance Building, 28 Church Square, Pretoria. 29/10/87, 10h00, Potgietersrus.
- T1995/87—**Buitendag**, Carel Hendrik; Matthew Klein, p/a Klein-Slot Trustees, Posbus 5437, Pretoria, 0001. 29/10/87, 10h00, Pretoria-Noord.
- T1006/87—**Coetzee**, D. J.; J. F. McMenamin, c/o Fortiter Trust, Posbus 4626, Pretoria, 0001. 4 November 1987, 10h00, Pretoria.
- T2070/87—**Matthee**, S. J.; D. H. Rheeder, p/a Republiek Trustees, Posbus 3410, Pretoria, 0001. 30/10/87, 09h00, Pietersburg.
- T767/87—**Botes**, Gerhardus Stephanus; J. R. Galloway, Posbus 16185, Doornfontein, 2028. 6/11/87, 10h00, Pretoria.
- T870/87—**Citystate SA (Edms.) Bpk.**, in likwidasie; J. R. Galloway & J. L. C. Fourie, Posbus 16185, Doornfontein, 2028. 10/11/87, 09h00, Johannesburg.
- T788/87—**Koen**, Sally-Anne; J. R. Galloway, Posbus 16185, Doornfontein, 2028. 4/11/87, 09h00, Kempton Park.
- T1576/87—**Moshoeshoe**, S. T.; C. R. G. Fisher, c/o Coopers & Lybrand Trust (Pty) Ltd, P.O. Box 139, Johannesburg, 2000. 29/10/87, 9 a.m., Johannesburg.
- T1429/87—**Kohle**, R. en S. Kohle; M. R. Nesbitt, c/o Metrust Ltd, P.O. Box 32225, Braamfontein, 2017. 29/10/87, 09h00, Johannesburg.
- T1610/87—**Poggiali-Trapani**, Leonard; M. R. Nesbitt, c/o Metrust Ltd, P.O. Box 32225, Braamfontein, 2017. 27/10/87, 09h00, Johannesburg.
- T3346/86—**Laubscher**, Elbert Lukas, tans woonagtig te plaas Tweefontein, Warmbad; Jan Smit Venter, p/a Cape Trustees Bpk., Negende Verdieping, Ou Mutualsentrum, Andriesstraat 167, Pretoria, 0002. 4/11/87, 10h00, Warmbad.
- T1752/87—**Geyser**, Hendrik Josephus, woonagtig te die plaas Sterkfontein, Naboomspruit, gebore 21/8/45, Id. No. 4508215012004; J. H. van Rensburg, p/a Cape Trustees Bpk., Ou Mutualsentrum, Andriesstraat 167, Negende Verdieping, 0002. 30 Oktober 1987, 10h00, Naboomspruit.
- T1539/87—**Muller**, Christiaan Pieter, voorheen handelendrywende as Muller's Electrical, van Chrisalexgebou 5, Gardenerstraat, Risiville, Vereniging; J. H. van Rensburg, p/a Cape Trustees Bpk., Ou Mutualsentrum, Andriesstraat 167, Negende Verdieping, Pretoria, 0002. 30 Oktober 1987, 10h00, Vereniging.
- T1803/87—**McGuire**, N.; C. J. Uys, p/a Trust Validus, Posbus 36216, Menlo Park, 0102. 6 November 1987, 09h30, Evander.
- N229/87—**Dadamia**, Mohamed Aslam Mustupha; K. D. Krumm, c/o Syfrets Trust Ltd, P.O. Box 135, Durban, 4000. 3 November 1987, 9.00 a.m., Durban.
- N477/86—**Stokes**, Christo Jacobus; V. S. Seipp, joint trustee, P.O. Box 3569, Durban, 4000, G. H. J. Venter, joint trustee, P.O. Box 1474, Johannesburg. 27 October 1987, 09h00, Durban.
- T921/87—**Softword (Pty) Ltd**; F. G. Gay, c/o Felix Gay Trust (Pty) Ltd, 305 Volkskas Building, 76 Market Street, Johannesburg, 2001. 10 November 1987, 09h00, Johannesburg.
- T1321/87—**Struwig**, Nicolaas Johan; F. G. Gay, c/o Felix Gay Trust (Pty) Ltd, 305 Volkskas Building, 76 Market Street, Johannesburg, 2001. 4 November 1987, 09h00, Alberton.
- T1560/87—**Sprong**, Marius; J. M. Oelofsen, c/o Felix Gay Trust (Pty) Ltd, 305 Volkskas Building, 76 Market Street, Johannesburg, 2001. 4 November 1987, 09h00, Kempton Park.
- T844/87—**Fernandes**, V. C.; F. G. Gay, c/o Felix Gay Trust (Pty) Ltd, P.O. Box 260404, Excom, 2023. 1987-10-29, 09h00, Johannesburg.
- T2215/86—**Van den Berg**, Mathinus Jacobus; J. M. Oelofsen, c/o Felix Gay Trust (Pty) Ltd, 305 Volkskas Building, 76 Market Street, Johannesburg, 2001. 11 November 1987, 10h00, Potchefstroom.
- T1656/87—**White**, Kevin Ian, Id. No. 5907215139008, formerly trading as Azalea Home Ideas and Florist; C. P. van Zyl, c/o Progressive Administration & Management CC, Reg. No: 87/02814/23, P.O. Box 1183, Randburg, 2125. 18/11/87, 9 a.m., Kempton Park.
- T1845/87—**Bartle**, E. P.; D. J. Rennie, c/o Syfrets Trust Ltd, P.O. Box 61058, Marshalltown, 2107. 29 October 1987, 9.00 a.m., Johannesburg.
- T1987/87—**Tutuka Stores (Pty) Ltd**; L. Klopper, Posbus 1990, Pretoria. 4 November 1987, 09h00, Johannesburg.
- T339/87—**Venter**, N. E.; T. C. Muller, Posbus 1990, Pretoria. 13 November 1987, 10h00, Pretoria.
- T1941/87—**Arberne**, D. D. R.; T. C. Muller, Posbus 1990, Pretoria. 11 November 1987, 08h30, Rustenburg.
- T1535/87—**Van Wyk**, S. H.; T. C. Muller, Posbus 1990, Pretoria. 26 October 1987, 09h00, Lichtenburg.
- T2941/86—**Van der Watt**, A. J.; L. Klopper, Posbus 1990, Pretoria. 6 November 1987, 09h00, Standerton.
- T855/87—**Van de Rbeede**, J. H.; L. Klopper, Posbus 1990, Pretoria. 4 November 1987, 10h00, Klerksdorp.
- T1122/87—**Scholtz**, P. C.; L. Klopper, Posbus 1990, Pretoria. 4 November 1987, 10h00, Ventersdorp.
- T332/87—**Horn**, W. M.; L. Klopper, Posbus 1990, Pretoria. 6 November 1987, 09h30, Krugersdorp.
- T4803/86—**Momberg**, D.; L. Klopper, Posbus 1990, Pretoria. 5 November 1987, 10h00, Bronkhorstspuit.
- T2206/87—**Strydom**, R. G. P.; L. Klopper, Posbus 1990, Pretoria. 4 November 1987, 10h00, Potchefstroom.
- T420/87—**Van der Schyff**, W. N.; L. Klopper, Posbus 1990, Pretoria. 4 November 1987, 10h00, Ventersdorp.
- T2027/87—**Van Tonder**, Gerhardus Jacobus Jacob, Tygerbergstraat 1, Vaalpark, Sasolburg, Id. No. 241125057006; A. J. Hessels, p/a Metboard (Pta) Bpk., Posbus 3127, Pretoria. 6/11/87, 10h00, Pretoria.
- T1964/87—**Shakalli**, Jacovos, Weststraat 5, Groblersdal, gebore 21/10/51; J. H. van Blerk, p/a Metboard (Pta) Bpk., Posbus 3127, Pretoria. 30/10/87, 08h30, Groblersdal.
- T379/87—**Van der Ben**, J.: J. N. van der Westhuizen, Posbus 209, Randburg, 2125. 28/10/87, 09h00, Alberton.
- T1546/87—**Bothma**, Margaretha Johanna Isabella; P. W. M. Reynolds c/o Arthur Young Trust & Management Co. (Pty) Ltd, 15th Floor, Main Central, 112 Main Street, Johannesburg. 5/11/87, 09h00, Johannesburg.

Vorm/Form 2**BYEENKOMS VAN SKULDEISERS IN GESEKWESTREERDE BOEDEL OF
MAATSKAPPE IN LIKWIDASIE**

Ingevolge artikels 41 en 42 van die Insolvensiewet, 1936, artikels 179 en 182 van die Maatskappywet, 1926, en artikels 339 en 366 van die Maatskappywet, 1973, word hierby kennis gegee dat 'n byeenkoms van skuldeisers in die gesekwestreerde boedels of maatskappe in likwidasie hieronder vermeld, gehou sal word met aanduiding van die nommer van boedel/maatskappy; die naam en beskrywing van boedel/maatskappy; die datum, uur en plek van byeenkoms en die doel van byeenkoms.

In 'n plek waarin 'n kantoor van 'n Meester is, word die byeenkoms voor die Meester en in ander plekke voor die Landdros gehou.

**MEETING OF CREDITORS IN SEQUESTERED ESTATES OR
COMPANIES BEING WOUND UP**

Pursuant to sections 41 and 42 of the Insolvency Act, 1936, sections 179 and 182 of the Companies Act, 1926, and sections 339 and 366 of the Companies Act, 1973, notice is hereby given that a meeting of creditors will be held in the sequestered estates or companies being wound up mentioned below, indicating the number of estate/company; the name and description of estate/company; the date, hour and place of meeting and the purposes of meeting.

Meetings in a place in which there is a Master's Office, will be held before the Master; elsewhere they will be held before the Magistrate.

- T3926/86—**Kruger**, Frans Johannes. 28 Oktober 1987, 11h00, Heidelberg. Further proof of claims.
 N466/86—**Polly Shorts (Pty) Ltd**, in liquidation. 3 November 1987, 09h00, Durban. Special meeting for the proof of claims.
 N167/87—**Stephen**, Gabriel Jacob. 3 November 1987, 09h00, Durban. Final statutory meeting for the proof of claims.
 T1080/87—**Roux**, Andries Jacobus, voorheen handeldrywende as Morgenson Bouers. 23 Oktober 1987, 10.00 vm., Pretoria. Bewys van eise.
 T7/85—**Ross**, George Pirdia. 29/10/87, 9 a.m., Johannesburg. Further proof of claims.
 N251/86—**Jansen van Rensburg**, Albertus Hermanus. 23 Oktober 1987, 09h00, Empangeni. Special meeting for proof of claims.
 T211/87—**Williams**, Michael Keith Tomaselli. 3/11/87, 09h00, Johannesburg. Proving of late claims.
 K136/86—**Joubert**, Cornelius. 4 November 1987, 10h00, Hoopstad. Om verdere eise te bewys.
 B25/87—**White**, Sanette, woonagtig te Philipstraat 54, Parys, OVS. 21 Oktober 1987, 10h00, Parys. Bewys van eise.
 B455/86—**Barnard**, Jean Prieur, tydens sekwestrasie woonagtig te De Bruynstraat 64, Bloemfontein. 28 Oktober 1987, 10h00, Bloemfontein. Bewys van verdere eise.
 K3/84—**Balmoral Diamond Mining Company (Pty) Ltd**, in liquidation. 13 November 1987, 10h00, Kimberley. Further proof of claims.
 T242/83—**Hyper-Purchasing Company (Pty) Ltd**, in liquidation. 10 November 1987, 09h00, Johannesburg. Further proof of claims.
 T1611/86—**Levin**, Roy. 10 November 1987, 09h00, Johannesburg. Further proof of claims.
 T2843/84—**Vintage Wines and Cigars (Pty) Ltd**, in liquidation. 3 November 1987, 09h00, Johannesburg. Further proof of claims.
 C357/84—**Van der Spuy**, P. J. J., Identity No. 5510295043004. 4/11/87, 10.00 a.m., Mossel Bay. Further proof of claims.
 N294/86/2A—**Electro-Air (Pty) Ltd**, in liquidation. 30 Oktober 1987, 10h00, Pietermaritzburg. Special meeting for the proof of a late claim.
 C427/87—**Maree**, Abraham Johannes. 28 Oktober 1987, 09h00, Kuilsrivier. 1. Vorderings teen boedel te bewys. 2. Ontvang van kurators verslag.
 3. Opraagte te gee.
 B20/87—**Wepener**, Georg Frederik, tydens sekwestrasie woonagtig te Eksteenstraat 15, Kroonstad. 4 November 1987, 10h00, Kroonstad. Om verdere eise te bewys.
 K107/86—**Van Niekerk**, Willem Andries Petrus. 28 Oktober 1987, 10h00, Kimberley. Om eise te bewys.
 B742/86—**Bouwer**, A. D. 26 Oktober 1987, 09h30, Odendaalsrus. Om eise te bewys.
 T2931/86—**Sacks**, S. D. 23 Oktober 1987, 09h30, Germiston. Proof of claims.
 K24/87—**Taylor**, Johannes Jacobus Wagner, handeldrywende as Kokkies Hardeware. 28 Oktober 1987, 10h00, Kimberley. Om verdere eise te bewys.
 T4391/86—**Dallas**, Athanassios, formerly trading as Piero and Angela. 27/10/87, 9 a.m., Johannesburg. Further proof of claims.
 B652/86—**Scheepers**, Petrus Johannes. 21 Oktober 1987, 10h00, Bloemfontein. Spesiale vergadering van skuldeisers, bewys van laat eise.
 E43/87—**Morton**, Esme Mary. 28 Oktober 1987, 2 p.m., Port Elizabeth. Proof of debt.
 E30/87—**Van der Watt**, Cornelius Johannes, formerly trading as Cottage Restorers. 30 Oktober 1987, 10 a.m., Graaff-Reinet. Proof of debt.
 T3036/86—**Janse van Vuuren**, Heinrich Albertus, Von Wiellighstraat 47, Meyerton, Tvl. 23 Oktober 1987, 10h00, Meyerton. Bewys van verdere eise.
 C1064/85—**Villet**, Henry. 27 Oktober 1987, 09h00, Cape Town. Proof of claim.
 C847/85—**Kahn**, Dawood. 30 Oktober 1987, 09h00, Cape Town. Proof of claim.
 E97/87—**Holl**, Christiaan Johannes Hatingh, who resides at 13 Grasson Marina Vista, George Walker Street, East London. 23 Oktober 1987, 10 a.m., East London. Further proof of claims.
 E95/87—**Nel**, Jeanette Hilda Louise, who carried on business as Jen's Florist at Checkers, Old Market Building, Oxford Street, East London. 23 Oktober 1987, 10 a.m., East London. Further proof of claims.
 E121/87—**Shoehyper Close Corporation**, in liquidation, with registered office at Third Floor, NBS Building, 15 Terminus Street, East London. 23 Oktober 1987, 10 a.m., East London. Further proof of claims.
 E11/87—**Mayat**, Suleman Goolam, trading as Jet Supermarket, Queenstown. 23 Oktober 1987, 10 a.m., East London. Further proof of claims.
 E273/86—**Spencer**, John Saunders, who resides at Crowlands, Ugie, in the District of Maclear. 23 Oktober 1987, 10 a.m., Maclear. Further proof of claims.
 E116/87—**Jose**, Ronald George, who resides at 77 Princess Alice Drive, Nahoon Mouth, East London. 30 Oktober 1987, 10 a.m., East London. Further proof of claims.
 C1028/86—**Glasburg**, Haviland Alfred. 30 Oktober 1987, 09h00, Cape Town. Proof of claims.
 C224/87—**Kleinbans**, Evert Pieter, Identity No. 5709165101008. 20 November 1987, 10h00, Riversdal. Proof of claim.
 C129/87—**Nicholas**, Alfred Edward. 10 November 1987, 09h00, Cape Town. Proof of claim.
 C90/87—**Olivier**, Petrus Johannes, Identity No. 5312015104007. 25 November 1987, 10h00, Stellenbosch. Proof of claim.
 C462/86—**Braunpave (Pty) Ltd**, in liquidation. Company Registration No. 71/02535/07. 29 Oktober 1987, 9.00 a.m., Wynberg. For proof of claims.
 T3663/85—**Hoffman**, Jacob de Villiers. 30/10/87, 09h30, Krugersdorp. Proof of claims.

- T225/87—**Nieuwoudt**, Jacobus Cornelius. 2/11/87, 10h00, Brits. Proof of claims.
 T1313/87—**Joubert**, P. J. 30/10/87, 10h00, Springs. Further proof of claims.
 T634/87—**Snyman**, A. B. 23 Oktober 1987, 09h00, Nylstroom. Bewys van verdere eise.
 T4350/86—**Human**, H. J. 28 Oktober 1987, 09h00, Ellisras. Bewys van verdere eise.
 T2697/86—**Gilroy**, D. M. 23 Oktober 1987, 09h00, Delmas. Bewys van verdere eise.
 T59/87—**Swanepoel**, S. P. 23 Oktober 1987, 10h00, Pretoria. Bewys van verdere eise.
 T45/87—**Nel**, J. P. 23 Oktober 1987, 10h00, Pretoria. Bewys van verdere eise.
 T87/87—**Oosthuizen**, W. E. 27 Oktober 1987, 14h00, Waterval-Boven. Bewys van verdere eise.
 T4796/86—**Diener**, V. G. 28 Oktober 1987, 10h00, Middelburg. Bewys van verdere eise.
 T4683/86—**Vosloo**, J. M. 23 Oktober 1987, 10h00, Pretoria. Bewys van verdere eise.
 T2345/85—**Mouton**, A. J. 28 Oktober 1987, 09h00, Roodepoort. Bewys van verdere eise.
 T853/87—**Becker**, W. C. 23 Oktober 1987, 10h00, Pretoria. Bewys van verdere eise.
 T363/87—**Du Plessis**, W. J. I. M. 27 Oktober 1987, 10h00, Brits. Bewys van verdere eise.
 T123/87—**Feinstein**, Martin Azar, an adult male formerly residing at 24 Nigel Avenue, Selection Park, Springs, Identity Number 4409075005008, born on 7 September 1944. 28 Oktober 1987, 10h00, Pretoria. For the proof of further claims.
 T1068/86—**Smit**, Marius. 30/10/87, 09h30, Krugersdorp. Verdere bewys van eise.
 T493/87—**Marksman Sports (Edms.) Bpk.**, in likwidasie. 3/11/87, 09h00, Johannesburg. Verdere bewys van eise.
 T3904/86—**De Klerk**, M. A. 23 Oktober 1987, 09h00, Bethal. Verdere bewys van eise.
 T687/87—**Venter**, J. D. 23 Oktober 1987, 09h00, Pietersburg. Verdere bewys van eise.
 N5/87—**Joytree Investments (Pty) Ltd**, in liquidation. 27 Oktober 1987, 09h00, Durban. Proof of claims.
 N411/84—**Toropig Plumbing (Pty) Ltd**, in liquidation. 27 Oktober 1987, 09h00, Durban. Proof of claims.
 N53/87—**Windell**, R. A. C. 27 Oktober 1987, 09h00, Durban. Proof of claims.
 T2230/86—**Van Kaam**, Andre Christiaan. 4/11/87, 09h00, Johannesburg. Further proof of claims.
 B665/86—**Boshoff**, Marthinus Christoffel, tydens sekwestrasie woonagtig te die plaas Jessiesdale, Bothaville. 27 Oktober 1987, 10h00, Bothaville. Bewys van verdere eise.
 N69/87—**Nair**, V. M. 5 November 1987, 10.00 a.m., Pietermaritzburg. Proof of late claims and interrogation.
 T223/86—**Herbst**, John Henry. 28/10/87, 10h00, Middelburg. Bewys van eise.
 T590/87—**Steyn**, H. E. 30 Oktober 1987, 10h00, Pretoria. Bewys van verdere eise.
 T2961/86—**Beulen Sales (Pty) Ltd**. 30 Oktober 1987, 10h00, Pretoria. Bewys van verdere eise.
 T1322/87—**Timm**, A. R. 30 Oktober 1987, 10h00, Pretoria. Bewys van verdere eise.
 T4611/87—**Loots**, C. H. 30 Oktober 1987, 10h00, Pretoria. Bewys van verdere eise.
 T4485/86—**Low**, G. J. H. 30 Oktober 1987, 10h00, Pretoria. Bewys van verdere eise.
 T4062/86—**Maree**, J. H. P. 30 Oktober 1987, 10h00, Pretoria. Bewys van verdere eise.
 T1087/87—**Kruger**, Marthinus Johannes. 30 Oktober 1987, 9.00 a.m., Nelspruit. Further proof of claims.
 T4468/86—**Badenhorst**, W. A. 26/10/87, 09h00, Tzaneen. Verdere bewys van eise.
 T1475/87—**Du Toit**, R. J. 9/12/87, 10h00, Pretoria. Verdere bewys van eise.
 T1822/84—**Roberts**, D. J. E. 6/11/87, 09h00, Nelspruit. Verdere bewys van eise.
 C910/86—**Van As**, A. W. W. 4/11/87, 10h00, Vredenburg. Bewys van eise.
 C696/86—**Saayman**, S. F. 2/11/87, 10h00, Swellendam. Bewys van eise.
 T3684/86—**Lurie**, F. 29 Oktober 1987, 9.00 a.m., Johannesburg. Further proof of claims.
 T3886/86—**Barkowitz**, J. P. 28 Oktober 1987, 10.00 a.m., Potchefstroom. Further proof of claims.
 T1245/86—**Arbulon (Pty) Ltd**, handelsdrywende as Vogue Shoes. 29/10/87, 9.00 vm., Johannesburg. Bewys van eise.
 N290/87—**Buitendach**, H. R. D. 30 Oktober 1987, 10.00 a.m., Pietermaritzburg. Proof of claims.
 T450/87—**Vermooten**, C., trading as Lady Dine Restaurant and Moonlight Express. 29 Oktober 1987, 9.00 a.m., Johannesburg. Further proof of claims.
 B77/87—**Le Roux**, Gerrit Dirkze, gebore op 22 Mei 1955. 28 Oktober 1987, 10h00, Petrusburg. Om verdere eise te bewys.
 N731/85—**Interplumb (Tvl) (Pty) Ltd**. 10/11/87, 09h00, Johannesburg. Further proof of claims.
 T178/87—**Hobson**, Arthur Donald and Peggy Alexandra Hobson. 27 Oktober 1987, 9.00 a.m., Johannesburg. Proof of claims.
 C949/85—**Vogel**, W. F. 28 Oktober 1987, 10.00 a.m., Hermanus. For proof of claims.
 T179/86—**Locati Beleggings (Edms.) Bpk.** 29/11/88, 10h00, Pretoria. Verdere bewys van eise en die hou van 'n ondervraging.
 T1428/87—**Madadari BK**. 29/10/87, 10h00, Potgietersrus. Verdere bewys van eise.
 T4048/86—**De Wet**, J. I. 30/10/87, 10h00, Pretoria. Verdere bewys van eise.
 T4036/85—**Griessel**, G. de L. 4/11/87, 09h00, Roodepoort. Proof of claims.
 T3067/85—**Loots**, J. H. 30/10/87, 09h00, Nylstroom. Proof of claims.
 T3829/85—**Fourie**, D. J. 30/10/87, 10h00, Oberholzer. Proof of claims.
 T796/87—**Hendriks**, Albert. 4/11/87, 11h00, Heidelberg, Tvl. Proving of late claims.
 T4745/86—**George Kendall (Pty) Ltd**. 29/10/87, 09h00, Johannesburg. Proving of late claims.
 T943/87—**Marx**, Phillipus Johannes. 30/10/87, 10h00, Pretoria. Bewys van eise.
 T3838/86—**Fouche**, S. J. 6/11/87, 10h00, Pretoria. Bewys van eise.
 T1573/86—**Bezuidenhout**, P. J. 30/10/87, 09h00, Pietersburg. Verdere bewys van eise.
 T3684/85—**Du Plessis Nieman**, G. J. 5/11/87, 10h00, Potgietersrus. Verdere bewys van eise.
 T679/86—**Reyneke**, W. H. 30/10/87, 10h00, Witbank. Verdere bewys van eise.
 N303/86—**Gerrard**, Trevor. 27 Oktober 1987, 09h00, Durban. Proof of claims.
 N90/87—**Nelson**, Charles William. 27 Oktober 1987, 09h00, Durban. To prove claims.
 N157/87—**Peek-A-Boo (Pty) Ltd**, in liquidation. 3/11/87, 10.00 a.m., Durban. To call a second meeting of creditors.
 N158/87—**Waste Distributors (Pty) Ltd**, in liquidation. 3/11/87, 10.00 a.m., Durban. To call a second meeting of creditors.
 N156/87—**Atrish (Pty) Ltd**, in liquidation. 3/11/87, 10.00 a.m., Durban. To call a second meeting of creditors.
 N169/87—**Eschel Trading (Pty) Ltd**, in liquidation. 3/11/87, 10.00 a.m., Durban. To call a second meeting of creditors.
 T3982/86—**Truck & Brake Centre (Pty) Ltd**. 1987-10-29, 10h00, Pretoria North. Further proof of claims.
 T1056/87—**Ford**, Andrew. 29 Oktober 1987, 11h30, Boksburg. Proving of claims.
 T4095/86—**Horn**, M. F. and M. C. Horn. 30 Oktober 1987, 10h00, Brakpan. Proving of claims.
 T1283/86—**Van Zyl**, P. W. 1987-10-30, 09h00, Standerton. Further proof of claims.
 T1777/86—**Terblanche**, R. O. 1987-10-30, 09h00, Delmas. Further proof of claims.
 T696/86—**Vanhoff Trading (Pty) Ltd**. 1987-10-29, 09h00, Johannesburg. 1. Further proof of claims. 2. Passing of following resolutions:
 That all actions of whatsoever nature hereto before taken by the Provisional Liquidator and/or Liquidator be and are hereby confirmed, ratified and approved.
 That the Liquidator be and is hereby authorised to dispose of the movable and immovable assets of the company by public auction or private treaty on such conditions and after such advertisement as he in his sole discretion deems fit.
 That the Liquidator be and is hereby authorised at his discretion to abandon any asset for which he can find no purchaser, all costs incurred in relation thereto are to be dealt with as costs in the liquidation.

That the action of the Liquidator in disposing of the movable assets of the estate by public auction be and is hereby confirmed.

That the Liquidator be and is hereby authorised to, in his sole discretion, compromise or admit any claim against the company whether liquidated or unliquidated, arising from any guarantee, damages claim or any other cause whatsoever, as liquidated in terms of Section 78 (3) of the Insolvency Act as amended, that such amount as may be agreed upon by both the Liquidator and the creditor concerned, provided that proof thereof has been tendered at a meeting of creditors.

- T3089/86—**Power Finance & Estates (Pty) Ltd.** 30 October 1987, 9.30 a.m., Germiston. Further proof of claims.
- T3193/86—**McLean, J. and M. E. McLean**, trading as McLeans. 30 October 1987, 9.30 a.m., Germiston. Further proof of claims.
- T583/86—**Bolus, M. A.**, trading as Bodiflex. 27 October 1987, 9.00 a.m., Johannesburg. Further proof of claims.
- B206/87—**Atwell, A. G.** 4 November 1987, 11h00, Ladybrand. Om verdere eise te bewys.
- B758/86—**Payne, Allen Charles** en tans woonagtig te Swartruggensstraat 35, Vaalpark, Sasolburg. 26 Oktober 1987, 10h00, Sasolburg. Bewys van verdere eise.
- K105/86—**S. S. Thaw (Edms.) Bpk.**, voorheen handelende as Honda Spot. 4 November 1987, 10h00, Kimberley. Spesiale vergadering vir die bewys van eise.
- T483/87—**Jonker, M. F.** 28 October 1987, 9.00 a.m., Alberton. Further proof of claims.
- T3350/86—**Le Maitre, J. C. M.** 11 November 1987, 08h30, Rustenburg. Bewys van eise.
- T1637/86—**Welgemoed, P. S.** 30 October 1987, 10h00, Pretoria. Bewys van eise.
- T506/87—**Botha, F. J.** 28 October 1987, 10h00, Klerksdorp. Bewys van eise.
- T52/87—**Steyn, W. L.** 11 November 1987, 08h30, Rustenburg. Bewys van eise.
- T4167/86—**Cloete, J. H.** 26 October 1987, 09h00, Lichtenburg. Bewys van eise.
- T245/87—**Van Zyl, D. P.** 28 October 1987, 10h00, Klerksdorp. Bewys van eise.
- T3194/86—**Swart, L. G. P.** 28 October 1987, 10h00, Pretoria. Bewys van eise.
- T3544/86—**Du Preez, A. O.** 28 October 1987, 10h00, Pretoria. Bewys van eise.
- T1534/86—**Venter, J. R.** 4/11/87, 10h00, Pretoria. Verdere bewys van eise.

Vorm/Form 4

LIKWIDASIE-, DISTRIBUSIE- OF KONTRIBUSIEREKENINGS IN GESEKWESTREERDE BOEDELS OF MAATSKAPPE IN LIKWIDASIE

Ingevolge artikel 108 (2) van die Insolvensiewet, 1936, artikel 136 (2) van die Maatskappywet, 1926, en artikel 406 (3) van die Maatskappywet, 1973, word hierby kennis gegee dat die likwidasië-, distribusie- of kontribusierekenings in die boedels of die maatskappye, na gelang van die geval hieronder vermeld, ter insae van skuldeisers of kontribuante sal lê te die kantore van die Meesters en Landdroste daarin genoem, gedurende 'n tydperk van 14 dae, of die tydperk wat daarin vermeld is, vanaf die datum hieronder vermeld of vanaf die datum van publikasie hiervan, watter datum ook al die laatste is.

Die besonderhede word verstrek in die volgorde: Nommer van boedel/maatskappy; naam en beskrywing van boedel/maatskappy; beskrywing van rekening; rekening ter insae by Meester- en Landdroskantoor, datum, tydperk (indien langer as 14 dae).

LIQUIDATION ACCOUNTS AND PLANS OF DISTRIBUTION OR CONTRIBUTION IN SEQUESTERED ESTATES OR COMPANIES BEING WOUND UP

Pursuant to section 108 (2) of the Insolvency Act, 1936, section 136 (2) of the Companies Act, 1926, and section 406 (3) of the Companies Act, 1973, notice is hereby given that the liquidation account and plans of distribution or contribution in the estates or the companies mentioned below will lie open for inspection by creditors or contributories at the offices of the Masters and the Magistrates stated therein, for a period of 14 days, or for such a period as stated therein, from the date mentioned below or from the date of publication hereof, whichever may be the later date.

The particulars are given in the following order: Number of estate/company; name and description of estate/company; description of account; account for inspection at Master's and Magistrate's Office, date, period (if longer than 14 days).

- T974/86—**Roux, Maria Magdalena**, voorheen Herbst, gebore Kotzé, voorheen woonagtig te Georgiahof 1, Ferreirastraat 173, Kenilworth, Johannesburg. Eerste en Finale Likwidasië en Distribusie. Pretoria, Johannesburg.
- B614/85—**Penta Paper (Edms.) Bpk.**, in likwidasië. Gewysigde Eerste en Finale Likwidasië en Distribusie. Bloemfontein, 16 Oktober 1987.
- C905/85—**Pofaddersfontein (Pty) Ltd**, in liquidation. Amended Second and Final Liquidation and Distribution. Cape Town, Ceres, 16/10/87.
- C786/85—**S. L. Clark & Associates (Pty) Ltd**, in liquidation. Third Liquidation and Distribution. Cape Town, 16/10/87.
- T983/86/3B—**A. P. L. Kotze (Edms.) Bpk.**, eiendomsontwikkelaar. Eerste en Finale Likwidasië en Distribusie. Pretoria, Potchefstroom.
- C675/86/5A—**Kritzinger, C. J.** Eerste Likwidasië en Distribusie. Kaapstad, George, 16 Oktober 1987.
- T1443/86—**Watt, Desmond Peter**. First and Final Liquidation and Contribution. Pretoria, Johannesburg.
- T4524/86—**Meyer, Hilton**. First and Final Liquidation and Contribution. Pretoria, Roodepoort.
- T3061/86—**Bowman, A. D.** First Liquidation and Distribution. Pretoria, Johannesburg.
- E224/85—**Dereksen, Leon Johannes**. Supplementary Second and Final Liquidation and Distribution. Grahamstown, Aliwal North.
- T399/87/OND 11B—**Etiese Invoerders (Edms.) Bpk.**, in member's voluntary liquidation. First and Final Liquidation and Distribution. Pretoria, Johannesburg.
- B666/86 en B664/86—**Louw, David**, en Daisy Frede Louw. Eerste en Finale Likwidasië en Distribusie. Bloemfontein, 16 Oktober 1987.
- C727/86—**Smith, J. J. P.** First and Final Liquidation and Distribution. Cape Town, Bellville, 16/10/87.
- B626/86—**Roberts, Sarel Johannes**, tydens sekwestrasie woonagtig te Undaniplek 22, Virginia. Eerste en Finale Likwidasië en Distribusie. Bloemfontein, Virginia.
- C907/87—**Witz, Leslie**, Identity No. 4407075066004. First and Final Liquidation, Distribution and Contribution. Cape Town, 16/10/87.
- T1051/86—**P.M.I. Metal Windows (Pty) Ltd**, in liquidation. Second Liquidation and Distribution. Pretoria, 1987-10-16.
- T1397/86—**Christo van der Merwe (Pty) Ltd**, in liquidation. First and Final Liquidation and Distribution. Pretoria, Witbank, 1987-10-16.
- B697/86—**De Wet, Eugene Hubrecht**, tydens sekwestrasie woonagtig te Dan Pienaarylaan 135, Bloemfontein. Eerste en Finale Likwidasië en Distribusie. Bloemfontein.
- T3573/86/3B—**Joubosis (Edms.) Bpk.**, in voluntary liquidation. Liquidation. 16 October 1987.
- B5/87—**Van der Walt, A. J. H.** First and Final Liquidation and Distribution. Bloemfontein.
- B240/86—**Botha, Cheryl Dianne**. Tweede en Finale Likwidasië en Distribusie. Bloemfontein, 16/10/87.

- B264/85—**Mino (Edms.) Bpk.**, in likwidasie. Tweede en Finale Likwidasie en Distribusie. Bloemfontein, Bethlehem.
- T796/86—**Oberholzer, Matiam Jacobus**. First and Final Liquidation and Distribution. Pretoria, Oberholzer.
- B405/86 ASR—**Du Plessis, Pierre**. Eerste en Finale Likwidasie en Distribusie. Bloemfontein.
- B637/86—**Oosthuizen, Willem Albertus**, gebore op 20 November 1953, Identiteitsnommer 5311205150002. Eerste en Finale Likwidasie en Distribusie. Bloemfontein, Bothaville, 9 Oktober 1987.
- B639/86—**Oosthuizen, Louisa**, gebore op 29 November 1956, Identiteitsnommer 5611290119006. Eerste en Finale Likwidasie en Distribusie. Bloemfontein, Bothaville, 9 Oktober 1987.
- B302/86—**Trikir Investments (Pty) Ltd**, in likwidasie. Gewysigde Eerste en Finale Likwidasie en Distribusie. Bloemfontein, Welkom, 16 Oktober 1987.
- C745/86/5B—**Hyper Home Holdings (Pty) Ltd**, in creditors' voluntary liquidation. First and Final Liquidation and Contribution. Cape Town, Johannesburg, 16/10/87.
- T1875/85—**Trip a Day (Pty) Ltd**, in liquidation. Second and Final Liquidation and Distribution. Pretoria, Johannesburg, Alberton.
- T637/87—**Grasmere Food Holdings (Pty) Ltd**. First and Final Liquidation and Distribution. Pretoria, Johannesburg.
- C82/84/2B—**Josav (Pty) Ltd**, in voluntary liquidation. First and Final Liquidation and Distribution. Cape Town.
- B355/86—**Naude, S.** Bloemfontein, Bothaville.
- E430/86—**Vogel, Johannes Hendrikus**. Eerste Likwidasie en Distribusie. Grahamstad, Alexandria.
- C903/86/3A—**Kells, George**, trading as Car City. First Liquidation and Distribution. Cape Town.
- C777/86/2B—**Geo Elektriese- en Boukontraakteurs** (partnership). First Liquidation and Distribution. Cape Town, Heidelberg.
- C918/86/3B—**Bortoloso, G. G. L.**, trading as Claremont Panelbeaters, formerly Customcraft. First and Final Liquidation and Distribution. Cape Town, Wynberg.
- C386/86—**Baby Furn (Pty) Ltd**, in likwidasie. First Liquidation, Distribution and Contribution. Malmesbury, 16 October 1987.
- C399/86—**Insta Kitchens (Pty) Ltd**, in liquidation. Second and Final Liquidation and Distribution. Cape Town, 16 October 1987.
- C223/87—**Darryl Fine & Associates (Pty) Ltd**, in liquidation. First Liquidation and Distribution. Cape Town, 16 October 1987.
- E399/85—**De Klerk, David Edward**, who traded as Linear Electrical Services at 55 Clovelly Road, Sunnyridge, East London. Second and Final Liquidation and Distribution. Grahamstown, East London.
- E416/85—**Pretorius, Leon Pieter**, who traded as Middelburg Panelbeaters at Middelburg, Cape. Third and Final Liquidation and Distribution. Grahamstown, Middelburg.
- E354/85—**Pieters, Mark**, who traded as Lyn's Shoppe at 39 High Street, Grahamstown. Supplementary Second and Final Liquidation and Distribution. Grahamstown.
- T3107/86—**Thompson, Michael John**. First Liquidation and Distribution. Pretoria, Johannesburg.
- T4248/86—**Untiedt, Charlene Beverley**. First Liquidation and Distribution. Pretoria, Johannesburg.
- T1191/86—**Vincent, Frederick Joseph**. First and Final Liquidation and Distribution. Pretoria, Boksburg.
- T2867/86—**Kernel Poppins (Pty) Ltd**, in liquidation. First and Final Liquidation and Distribution. Pretoria, Johannesburg.
- B340/84—**Wesson, Philip Morris**. Aanvullende Likwidasie en Distribusie. Bloemfontein, Ficksburg.
- C404/87/4—**Hollandia Trust and Investment Corporation (Pty) Ltd**, in voluntary liquidation. First and Final Liquidation and Distribution. Cape Town.
- T943/87—**Marx, Phillipus Johannes**. Eerste Likwidasie, Verdelings en Kontribusie. Pretoria.
- T483/85—**Kevin Davidson Construction (Pty) Ltd**, in liquidation. First Liquidation and Distribution. Pretoria, Johannesburg, Randburg.
- T1680/86—**Joubert, Nicolaus Schultatus Havenga**. First and Final Liquidation and Distribution. Pretoria, Bethal.
- T3970/86—**Hoal, Graham Richard**. Second and Final Liquidation and Distribution. Pretoria.
- T2631/86—**United Metal Pressings (Edms.) Bpk.**, in likwidasie. Eerste en Finale Likwidasie en Kontribusie. Pretoria, 16/10/87.
- T671/86—**Du Plooy, R. A.** Eerste Likwidasie en Verdelings. Pretoria, Klerksdorp. 16/10/87.
- T1994/84—**Jones, W. C.** Tweede Likwidasie en Verdelings. Pretoria, Koster, 16/10/87.
- T425/86—**Knipeland Food Manufacturers (Edms.) Bpk.**, in likwidasie. Eerste en Finale Likwidasie en Kontribusie. Pretoria, Vryburg, 16/10/87.
- T2617/86—**Koppel, A. W.** Eerste en Finale Likwidasie en Verdelings. Pretoria, Klerksdorp, 16/10/87.
- T867/86/7B—**Jones, Gregory**. First Liquidation and Distribution. Pretoria, Kempton Park.
- T4387/86—**Plo, Oliver Arthur**. First Liquidation and Distribution. Pretoria, Boksburg.
- T2653/86—**Reyneke, Hermanus Lambertus**, Identity No. 4902265020001. Second and Final Liquidation and Distribution. Pretoria.
- T1883/86—**Fanfoni, Alfredo**, Identity No. 4911185047002. First Liquidation and Distribution. Pretoria.
- T2355/86—**Big Wheel Products (Edms.) Bpk.**, in liquidation. Second and Final Liquidation and Distribution. Pretoria.
- N177/81—**Liebenberg, D. P.** Seventh and Final Liquidation. Pietermaritzburg.
- E7/85/1A—**Paint O Rama (Pty) Ltd**, in liquidation, with registered office at 17 Sixth Avenue, Shopping Centre, Walmer, Port Elizabeth. Second and Final Liquidation and Distribution. Grahamstown, Port Elizabeth.
- B331/86—**Coetzee, Abraham Jacobus**, woonagtig te Willelaan 12, Frankfort, en 'n direkteur van Fort Bouers (Edms.) Bpk., in likwidasie. Eerste Aanvullende tot die Eerste en Finale Likwidasie en Distribusie. Bloemfontein, Frankfort.
- N491/86—**Blakey & Hope (Pty) Ltd**, in liquidation. First Liquidation and Distribution. Pietermaritzburg, Durban.
- B447/85—**Wessels, Gert Johannes Pretorius**, Ray Championlaan 1, Rayton, Bloemfontein. Eerste Aanvullende tot die Eerste en Finale Likwidasie en Distribusie. Bloemfontein.
- B609/85—**Horak, E. B.** Supplementêre Eerste en Finale Likwidasie en Distribusie. Bloemfontein, Marquard.
- E371/86—**D & A Machine Tools (Pty) Ltd**, in liquidation, with registered office at Third Floor, 18 Terminus Street, East London. First Liquidation and Distribution. Grahamstown, East London.
- C1060/85/6B—**Assembly Towers (Pty) Ltd**, in voluntary liquidation. First and Final Liquidation and Distribution. Cape Town, Bellville.
- C469/86/6B—**Herman Dasse (Pty) Ltd**, in liquidation. Amended First and Final Liquidation, Distribution and Contribution. Cape Town.
- C625/86/5A—**Pacific Services (Pty) Ltd**, in liquidation. First and Final Liquidation and Distribution. Cape Town, Bellville.
- T2485/86—**Korb, Johannes Lodiwicus**, formerly trading as J. L. Korb Transport. First and Final Liquidation, Distribution and Contribution. Pretoria, Germiston.
- T1920/83—**John Bull S.A. (Pty) Ltd**, in liquidation. Amended Second Liquidation and Distribution. Pretoria, Kempton Park.
- T4117/86—**Matcor Construction Inc. (Pty) Ltd**, in liquidation. First and Final Liquidation and Distribution. Pretoria, Vereeniging.
- T4234/86—**Sellers, Alan Ferdinand**. First and Final Liquidation. Pretoria, Johannesburg.
- T4223/86—**Sequire, Manuel Roberto**. First and Final Liquidation and Contribution. Pretoria, Krugersdorp.
- T967/87—**Kasimatis, Demitrios**. First and Final Liquidation and Contribution. Pretoria, Johannesburg.
- T1087/83—**VIP Hotels (Pty) Ltd**, in liquidation. First Liquidation and Distribution. Pretoria, Krugersdorp.
- T4144/86—**Denbro Outfitters (Pty) Ltd**, in liquidation. First Liquidation and Distribution. Pretoria, Kempton Park.
- T4300/86—**Trusler, Spencer, and Jacqueline Ann Trusler** (joint estate). First Liquidation and Distribution. Pretoria, Randburg.
- T188/87—**Hobson, Kenneth Arthur, and Sandra Hobson** (joint estate). First and Final Liquidation and Contribution. Pretoria, Alberton.
- T2401/86—**Le Grange, Jacobus Henry**. Supplementary First and Final Liquidation and Distribution. Pretoria, Johannesburg.
- T2747/86—**Preiss, Gabriel Jacobus**. First and Final Liquidation and Distribution. Pretoria, Krugersdorp.
- T178/87—**Hobson, Arthur Donald, and Peggy Alexandra Hobson**. First Liquidation and Distribution. Pretoria, Johannesburg.
- T3135/87—**Milton Motors CC**, in liquidation. First and Final Liquidation and Contribution. Pretoria, Klerksdorp.
- E273/86—**Spencer, John Saunders**, who traded as Crowlands Products at Ugie in the District of Maclear. First Liquidation and Disatribution. Grahamstown, Ugie, Maclear.

- T80/86—**Steenkamp, Barend Johannes Jr.** Second and Final Liquidation and Distribution. Pretoria.
 T1776/86—**Du Toit, Francois Wilhelmus.** First and Final Liquidation and Contribution. Pretoria, Vanderbijlpark.
 T666/86—**Massyn, Frans Peter.** First and Final Liquidation and Contribution. Pretoria, Nelspruit.
 T964/86—**Soweto Taxi Service Stations (Pty) Ltd.** First and Final Liquidation and Contribution. Pretoria, Johannesburg.
 T709/86—**Electrical Planning Construction (Pty) Ltd.** First and Final Liquidation and Contribution. Pretoria, Johannesburg.
 T3580/86—**Damaskindes, John.** First and Final Liquidation and Distribution. Pretoria, Johannesburg.
 T397/86—**Van Lill, Dirk Frederick Louw.** First and Final Liquidation and Contribution. Pretoria.
 T4032/86—**Addy Lanning Advertising (Pty) Ltd.** First and Final Liquidation and Distribution. Pretoria, Johannesburg.
 T4274/86—**De Beer, Letitia.** First and Final Liquidation and Distribution. Pretoria, Brakpan.
 T3270/85—**D'Fence Security Consultants (Pty) Ltd.** Second and Final Liquidation and Distribution. Pretoria, Johannesburg.
 T524/86—**Daisy & Lang Street Properties (Pty) Ltd,** in voluntary liquidation. First and Final Liquidation and Distribution. 16 October 1987.
 T4751/86—**Van der Meij, L. P.** First and Final Liquidation and Distribution. Pretoria, Vereeniging.
 T3224/86—**G 1 Construction (Pty) Ltd,** in liquidation (Reg. No. 81/012542/07). Second and Final Liquidation and Distribution. Pretoria, Johannesburg.
 T3697/86—**Black, V. R.** First and Final Liquidation and Distribution. Pretoria, Springs.
 T4063/85—**Monray Investments (Pty) Ltd.** Supplementary First and Final. Pretoria, Johannesburg.
 C568/86—**Camberwell Motors (Pty) Ltd,** in liquidation. First Liquidation and Distribution. Cape Town, Wynberg, 16/10/87.
 T253/85—**Fun Holdings (Edms.) Bpk.** Gewysigde Eerste en Finale Likwidasië en Kontribusie. Pretoria, Johannesburg.
 T2829/86—**Van Tonder, W. J. J.** Eerste en Finale Likwidasië en Kontribusie. Pretoria.
 T4289/86—**Muller, D. J.** Eerste en Finale Likwidasië. Pretoria.
 T2272/86—**Becker, J. D. P.** Eerste en Finale Likwidasië, Verdelings en Kontribusie. Pretoria, Vanderbijlpark.
 T2524/86—**Van der Merwe, J. J.** Eerste en Finale Likwidasië, Verdelings en Kontribusie. Pretoria.
 T4064/86—**Nell, Delarey.** First and Final Liquidation. Pretoria, Germiston.
 T2231/86—**Pagne (Pty) Ltd,** in liquidation. First Liquidation and Distribution. Pretoria, Johannesburg.
 T616/86—**Lumilte (Pty) Ltd,** in liquidation. Second and Final Liquidation and Distribution. Pretoria, Johannesburg.
 T1824/86—**Roodekop Steel Structures (Pty) Ltd,** in liquidation. Supplementary First and Final Liquidation and Distribution. Pretoria, Boksburg.
 T2888/86—**Gourmet Restaurants (Pty) Ltd,** in liquidation. First and Final Liquidation and Distribution. Pretoria, Johannesburg.
 T3949/86—**Rosenthal, K. J.** First Liquidation and Distribution. Pretoria, Johannesburg.
 T114/83—**Schindler, H. H. S.** Sixth Liquidation and Distribution. Pretoria, Randburg.
 T330/83—**JD & BT Motors (Pty) Ltd,** in liquidation. Fifth and Final Liquidation and Distribution. Pretoria, Vereeniging.
 T3785/86—**Levancon (Pty) Ltd,** in liquidation. First Liquidation and Distribution. Pretoria, Randburg.
 T4008/86—**Eliakim, Maurice.** First and Final Liquidation and Distribution. Pretoria, Johannesburg.
 T2312/86—**C. J. Watkin & Associates (Pty) Ltd,** in liquidation. First Liquidation and Distribution. Pretoria, Johannesburg.
 T57/86—**Children of the Universe (Pty) Ltd,** in liquidation. Second and Final Liquidation and Distribution. Pretoria, Johannesburg.
 T2579/85—**Econ O Clean (Pty) Ltd,** in liquidation. Second and Final Liquidation and Distribution. Pretoria, Johannesburg.
 T2099/86—**Meyer, E. E.** First and Final Liquidation and Contribution. Pretoria, Witbank.
 E49/85—**Rovan Landgoed (Pty) Ltd,** in voluntary liquidation. First and Final Liquidation and Distribution. Grahamstown, Port Elizabeth.
 E129/80—**Massyn, Stephanus Phillipus.** Tenth Liquidation and Distribution. Grahamstown, Port Elizabeth.
 E237/86—**Wooldridge, Basil Dennis.** Second and Final Liquidation and Distribution. Grahamstown, Humansdorp.
 E195/85—**Van Wyk, Pieter Johannes.** Second Liquidation and Distribution. Grahamstown, Port Elizabeth.
 E120/84—**Green, Daniel Johannes,** formerly trading as Sydney's Elektriese Dienste. Supplementary Liquidation and Distribution. Grahamstown, Graaff-Reinet.
 E170/81—**Godley, John Robert.** Supplementary Liquidation and Distribution. Grahamstown, Port Elizabeth.
 E262/86—**McKenzie-Ross, Kenneth Frederick,** formerly trading as La Mystique. Second and Final Liquidation and Distribution. Grahamstown, Port Elizabeth.
 E412/86—**McFadyen, Ian Hamilton.** First and Final Liquidation. Grahamstown, Port Elizabeth.
 E253/85—**Dias Multisave Supermarket and Butchery (Partners: Christopher Hugh Allwright and Sandra Ranwell).** Second Liquidation and Distribution. Grahamstown, Alexandria.
 E373/86—**Verster, Albertus Adrian.** First Liquidation and Contribution. Grahamstown, Port Elizabeth.
 T2262/86—**Koralsh (Pty) Ltd.** First and Final Liquidation and Contribution. Pretoria, Krugersdorp, 16/10/87.
 T1695/86—**Smith, J. Z. M.** Eerste en Finale Likwidasië, Distribusie en Kontribusie. Pretoria, Parys.
 E137/80—**Butler, Bruce Owen.** Supplementary Fourth and Final Liquidation and Distribution. East London, Grahamstown, 16 October 1987.
 6971/85—**Lategan, Wilhelmus Schoeman.** Eerste en Finale Likwidasië en Verdelings. Pretoria, Barberton.
 T3316/85—**Hillebrand, L. F., en J. Hillebrand.** Eerste en Finale Likwidasië en Verdelings. Pretoria.
 T2913/85—**Olivier, J. C.** Eerste Likwidasië en Verdelings. Pretoria, Barberton.
 T439/86—**Fourie, R. J.** Tweede Likwidasië en Verdelings. Pretoria, Brits.
 T43/86—**Fink, David Jeffrey.** First and Final Liquidation and Contribution. Pretoria, Johannesburg.
 T2837/86—**Booyesen, Johannes Petrus.** First and Final Liquidation, Distribution and Contribution. Pretoria, Kempton Park.
 T2266/86—**Fipso Bottling Co. (Pty) Ltd.** First and Final Liquidation and Contribution. Pretoria, Johannesburg.
 T3326/86—**Beukes, Anton Christiaan, and Susara Marie Beukes.** First and Final Liquidation and Distribution. Pretoria, Roodepoort.
 T2437/84—**Knoot, F. J.** Supplementary Second and Final Liquidation and Distribution. Pretoria, Randburg.
 T2658/85—**M and E Motor Engineering (Proprietary) Ltd,** in voluntary liquidation. First and Final Liquidation and Distribution. Pretoria, Krugersdorp.
 T916/86—**Van Heerden, J. C.** Eerste Likwidasië en Distribusie. Pretoria, 16/10/87–30/10/87.
 T927/85—**Colantoni Road & Earthworks (Edms.) Bpk.,** in likwidasië. Aanvullende Eerste en Finale Likwidasië en Distribusie. Pretoria, Johannesburg, Krugersdorp. 16/10/87–30/10/87.
 N12/87—**S.W.L. (Pty) Ltd.** First and Final Liquidation. Pietermaritzburg, Durban, 16 October 1987.
 N630/86—**Whitward Becker and Bense (Pty) Ltd.** First and Final Liquidation and Distribution. Pietermaritzburg, Durban.
 N629/86—**Quay Services (Pty) Ltd,** in voluntary liquidation. First and Final Liquidation and Distribution. Pietermaritzburg, Durban.
 N626/86—**Megafreight Holdings (Pty) Ltd,** in voluntary liquidation. First and Final Liquidation and Distribution. Pietermaritzburg, Durban.
 N625/86—**Megafreight (Pty) Ltd,** in voluntary liquidation. First and Final Liquidation and Distribution. Pietermaritzburg, Durban.
 T2917/85—**Stefanie, A.** Second and Final Liquidation and Distribution. Pretoria, Nigel, 1987-10-16.
 T2484/84—**Geldenbuys, Dennis Richard.** Revised Third and Final Liquidation and Distribution. Pretoria, Kempton Park.
 T3397/86—**Pugbe-Parry, R. D.** First and Final Liquidation and Distribution. Pretoria, Roodepoort, 16/10/87.
 T2569/86—**Power Brakes (Pietersburg) (Pty) Ltd.** First and Final Liquidation and Contribution. Pretoria, 16/10/87.
 T715/86—**Jacobson, M. C. C.** First and Final Liquidation and Contribution. Pretoria, Johannesburg, 16 October 1987.
 T863/86—**Oberholser, J. J., and A. S. Oberholser.** First and Final Liquidation and Distribution. Pretoria, Vereeniging, 16 October 1987.
 B140/87—**Strauss, Petrus Jacobus Maree.** First and Final Liquidation and Distribution. Bloemfontein, Hertzogville.
 T2468/86—**Mandav (Pty) Ltd,** members voluntary winding up. First and Final Liquidation and Distribution. Johannesburg.

- B644/86—**Ellisseou, Andrew**. First and Final Liquidation and Distribution. Parys, Bloemfontein.
 B744/86—**Van den Berg, Willem Nicolaas**. Eerste en Finale Likwidasië en Distribusie. Bloemfontein.
 T824/86—**Willcox, J. E.** First and Final Liquidation and Distribution. Pretoria, Germiston.
 T2693/85—**Four Seven Nought Investments (Pty) Ltd**, in liquidation. Supplementary First and Final Liquidation and Distribution. Pretoria, Johannesburg.
 T1454/86—**Goldwing Honda (Pty) Ltd**, in liquidation. First Liquidation and Distribution. Pretoria, Vanderbijlpark.
 T3133/85—**Antionne Wolmarans Design Associates (Pty) Ltd**, in liquidation. First and Final Liquidation and Distribution. Pretoria, Johannesburg.
 T1540/86—**Daglish, Thomas Richard James**, born on 29/1/46, formerly trading as Columbia Transport. First and Final Liquidation, Distribution and Contribution. Pretoria, Johannesburg, 16 October 1987.
 T2689/85—**Galtelband, Israel**. Revised Second and Final Liquidation and Distribution. Pretoria, Johannesburg, 16 October 1987.
 T4029/86—**Meintjies, J. A.** Eerste en Finale Likwidasië en Distribusie. Pretoria, Lichtenburg.
 T1256/86—**Tberon, T.** Eerste en Finale Likwidasië en Distribusie. Pretoria.
 T3363/86—**Els, C. D.** Eerste en Finale Likwidasië en Kontribusie. Pretoria, Rustenburg.
 T3373/86—**Els, N. J.** Eerste en Finale Likwidasië en Kontribusie. Pretoria, Rustenburg.
 T4544/86—**J. A. Meintjies (Edms.) Bpk.** Eerste en Finale Likwidasië en Distribusie. Pretoria, Lichtenburg.
 T3717/86—**Mostert, J. H.**, en **M. M. Mostert**. Eerste en Finale Likwidasië en Distribusie. Pretoria.
 T2657/84—**Botha, J. P.** Tweede Likwidasië en Distribusie. Pretoria, Rustenburg, Brits.
 T2573/86—**Bezuidenhout, I. M.** Eerste Likwidasië en Verdeling. Pretoria, Witbank.
 T2077/86—**Du Toit, J. J.** Eerste en Finale Likwidasië en Verdeling. Pretoria, Pietersburg.
 T3139/85—**Fourie, J. R.** Tweede en Finale Likwidasië en Verdeling. Pretoria, Witbank.
 T2797/85—**Trumble, I. E.** Derde Likwidasië en Verdeling. Pretoria, Nelspruit.
 T797/86—**Pohl, J. G.** Tweede en Finale Likwidasië en Verdeling. Pretoria.
 T767/86—**De Beer, C. H.** Supplementêre tot Eerste en Finale Likwidasië en Verdeling. Pretoria, Pietersburg.
 T1265/86—**Dercksen, C. J.** Tweede en Finale Likwidasië en Verdeling. Pretoria.
 T2859/84—**Storm, Le Roux**. Eerste en Finale Likwidasië en Verdeling. Pretoria, Hendrina.
 T1756/86—**Jordaan, W. C. L.** Eerste Likwidasië en Verdeling. Pretoria, Middelburg.
 T1671/86—**Fourie, G.** Eerste en Finale Likwidasië, Verdelings en Kontribusie. Pretoria, Potchefstroom.

Vorm/Form 5

UITKEER VAN DIVIDENDE EN INSAMELING VAN KONTRIBUSIES IN GESEKWESTREERDE BOEDELS OF MAATSKAPPYE IN LIKWIDASIE

Nademaal die likwidasiërekenings en distribusie- of kontribusierekenings in die gesekwestreerde boedels of maatskappye in likwidasië, na gelang van die geval, hieronder vermeld op die datums daarin vermeld, bekragtig is, word hierby ingevolge artikel 113 (1) van die Insolvensiewet, 1936, artikel 139 (2) van die Maatskappywet, 1926, en artikel 409 (2) van die Maatskappywet, 1973, kennis gegee dat uitbetaling van dividende of insameling van kontribusies aan die gang is in genoemde boedels of maatskappye soos hieronder uiteengesit en dat elke kontribusiepligtige skuldeiser die bedrag deur hom verskuldig by die adres hieronder genoem aan die kurator of likwidateur moet betaal.

Die besonderhede word verstrek in die volgorde: Nommer van boedel/maatskappy; naam en beskrywing van boedel/maatskappy en rekening; datum waarop rekening bekragtig is; of 'n dividend uitgekeer of 'n kontribusie ingevorder word, of beide, en naam en adres van kurator of likwidateur.

PAYMENT OF DIVIDENDS AND COLLECTION OF CONTRIBUTIONS IN SEQUESTERED ESTATES OR COMPANIES BEING WOUND UP

The liquidation accounts and plans of distribution or contribution in the sequestered estates or companies being wound up, as the case may be, mentioned below having been confirmed on the date therein mentioned, notice is hereby given, pursuant to section 113 (1) of the Insolvency Act, 1936, section 139 (2) of the Companies Act, 1926, and section 409 (2) of the Companies Act, 1973, that dividends are in the course of payment or contributions are in the course of collection in the said estates or companies as set forth below and that every creditor liable to contribution is required to pay to the trustee or liquidator the amount for which he is liable at the address mentioned below.

The particulars are given in the following order: Number of estate/company; name and description of estate/company and account; date when account confirmed; whether a dividend is being paid or contribution being collected, or both, and name and address of trustee or liquidator.

- T1112/85—**Kahn, Mervyn Geoffrey**. 18/9/87. Dividend. Neil Bowman, P.O. Box 10527, Johannesburg.
 T3040/85—**CBS Stainless Steel (Pty) Ltd**, in liquidation. 18/9/87. Dividend. Leslie Cohen, P.O. Box 10527, Johannesburg.
 T3471/85—**Millon Developments (Pty) Ltd**, in liquidation. 24/9/87. Preferent and secured award. Leslie Cohen, P.O. Box 10527, Johannesburg.
 T1822/86—**Fuhr Sales (Pty) Ltd**, in liquidation. 18/9/87. Preferent award. Leslie Cohen, P.O. Box 10527, Johannesburg.
 T2306/84—**Engelblik, Antoon Willem Hendrik**. 16/9/87. Preferent award. Norman Klein, P.O. Box 10527, Johannesburg.
 T616/86—**Lumlite (Pty) Ltd**, in liquidation. 21/9/87. Secured and preferent award. Neil Bowman, P.O. Box 10527, Johannesburg.
 B245/86—**OFS Industrial Cooling (Pty) Ltd**, in liquidation. Second and Final Liquidation and Distribution. 28 September 1987. A dividend is being paid. Dr C. Cilliers, c/o Webbers, P.O. Box 501, Bloemfontein.
 B682/86—**Jonker, Gert Johannes**, van die plaas Terra Bone, Senekal. 24/9/87. Dividende uitgekeer. R. D. du Plessis, p/a Symington & De Kok, Posbus 760, Bloemfontein, 9300.
 B508/86—**De Meyer, Jan Paul**, Horisonwoonstelle 49, Sasolburg en werksaam as operateur te Sasol 1, Sasolburg. 21/9/87. Dividende uitgekeer. R. D. du Plessis, p/a Symington & De Kok, Posbus 760, Bloemfontein, 9300.
 N743/85/2B—**Kinbrin Investments (Pty) Ltd**. 17/8/87. Dividend paid. A. M. Brokensha, P.O. Box 51, Pietermaritzburg, 3200.
 C159/86—**The Show Set Up (Pty) Ltd**, in liquidation. First and Final Liquidation and Distribution. 16/9/87. Award to preferent creditors. D. M. Meaker, c/o Metrust Ltd, P.O. Box 2476, Cape Town, 8000.
 B405/86—**Swan, Stephanus Paulus**. 11/9/87. Preferente dividende word uitbetaal. C. J. Venter, p/a Naudes, Posbus 153, Bloemfontein.

- B8/85—**Jooste**, Joachim Frederick Mentz. 22/9/87. Preferente en konkurrente dividende word uitbetaal. C. J. Venter, p/a Naudes, Posbus 153, Bloemfontein.
- T2181/85—**Du Toit**, Roelof Johannes, woonagtig te Koppie Alleenstraat, Perdekop, distrik Volksrust en voorheen 'n boer van Pongola. 21/9/87. Uitkeer dividende. Roelof Davel du Plessis, Posbus 760, Bloemfontein.
- C832/85—**Sassenberg**, H. D. First Liquidation and Distribution. 17/9/87. Award to secured creditors. D. M. Meaker and A. W. Bosch, c/o Metrust Ltd, P.O. Box 2476, Cape Town, 8000.
- B2/87—**Jansen van Vuuren**, Michael Christiaan, tydens sekwestrasie woonagtig te Doringstraat 2, Vaalpark, Sasolburg. 8/9/87. Geen. S. W. de Wet.
- B455/86—19/8/87. Preferente dividend. F. R. R. Neethling, p/a Naudes, Posbus 153, Bloemfontein.
- T848/86—**Strydom**, G. 21/9/87. Concurrent award. Norman Klein, P.O. Box 10527, Johannesburg.
- T3523/86—**Goodsko Catering (Pty) Ltd**, in liquidation. 22/9/87. Preferent award. Neil Bowman, P.O. Box 10527, Johannesburg.
- T2933/86—**Silver**, Sidney. 22/9/87. Contribution. Norman Klein, P.O. Box 10527, Johannesburg.
- T3472/85—**Gimpel**, H. 22/9/87. Preferent award. Neil Bowman, P.O. Box 10527, Johannesburg.
- T450/85—**Eastham**, Janet Ruth. Tweede en Finale Likwidasië en Distribusie. 18/9/87. Uitkeer dividende. F. B. Pretorius, p/a C. C. C. Raulstone & Kie., Posbus 536, Pietermaritzburg.
- B602/86—**Van Wyk**, Willem Wynand, tydens sekwestrasie woonagtig te Maraisstraat 36, Kroonstad. 11/9/87. Konkurrente dividend betaalbaar. S. W. de Wet, p/a Naudes, Posbus 153, Bloemfontein.
- B695/86—**Wentworth**, Hendricus Johannes, tydens sekwestrasie woonagtig te Kroonhof No. 1, Kroonstad. 15/9/87. Preferente dividend betaalbaar. S. W. de Wet, p/a Naudes, Posbus 153, Bloemfontein.
- B732/86—**R & J Konstruksie (Edms.) Bpk.**, in likwidasië, handeldrywende as sodanig te Botshabelo met geregistreerde hoofkantoor te Deane & Thresher, Eerste Laan 32, Bloemfontein. 16/9/87. Geen. George Frederik Wessels, p/a Symington & De Kok, Posbus 760, Bloemfontein.
- N442/86—**Van Wyk**, D. A. S. 23 September 1987. Dividend to preferent creditor. Ian L. Whiteford, c/o Coopers & Lybrand Trust (Pty) Ltd, P.O. Box 1945, Durban, 4000.
- N727/85—**Thomas Construction (Pty) Ltd**. 23 September 1987. Dividend to secured and preferent creditors. Ian L. Whiteford, J. A. Bruce, A. D. Wilkens and B. L. Kurz, c/o Coopers & Lybrand Trust (Pty) Ltd, P.O. Box 1945, Durban, 4000.
- C381/86—**Nich Five (Pty) Ltd**, in liquidation. First and Final Liquidation, Distribution and Contribution. 21 September 1987. Dividend paid and contribution collected. H. M. Sangiorgio and C. R. S. Gooden, for Coopers & Lybrand Trust (Pty) Ltd, 10th Floor, Shell House, 9 Riebeeck Street, Cape Town.
- C380/86—**Nich Four (Pty) Ltd**, in liquidation. First and Final Liquidation, Distribution and Contribution. 25 September 1987. Dividend paid and contribution collected. H. M. Sangiorgio and M. T. East, for Coopers & Lybrand Trust (Pty) Ltd, 10th Floor, Shell House, 9 Riebeeck Street, Cape Town, 8000.
- C379/86—**Nich Three (Pty) Ltd**, in liquidation. First and Final Liquidation, Distribution and Contribution. 24 September 1987. Dividend paid and contribution collected. H. M. Sangiorgio and C. R. S. Gooden, for Coopers & Lybrand Trust (Pty) Ltd, 10th Floor, Shell House, 9 Riebeeck Street, Cape Town.
- C378/86—**Nich Two (Pty) Ltd**, in liquidation. First and Final Liquidation, Distribution and Contribution. 22 September 1987. Dividend paid and contribution collected. H. M. Sangiorgio and C. R. S. Gooden, for Coopers & Lybrand Trust (Pty) Ltd, 10th Floor, Shell House, 9 Riebeeck Street, Cape Town.
- C377/86—**Nich One (Pty) Ltd**, in liquidation. First and Final Liquidation, Distribution and Contribution. 21 September 1987. Dividend paid and contribution collected. H. M. Sangiorgio and C. R. S. Gooden, for Coopers and Lybrand Trust (Pty) Ltd, 10th Floor, Shell House, 9 Riebeeck Street, Cape Town.
- C382/86—**Nich Six (Pty) Ltd**, in liquidation. First and Final Liquidation, Distribution and Contribution. 21 September 1987. Dividend paid and contribution collected. H. M. Sangiorgio and C. R. S. Gooden, for Coopers & Lybrand Trust (Pty) Ltd, 10th Floor, Shell House, 9 Riebeeck Street, Cape Town.
- C346/86—**Nich Properties (Pty) Ltd**, in liquidation. First and Final Liquidation and Contribution. 24 September 1987. Contribution collected. M. T. East, for Coopers & Lybrand Trust (Pty) Ltd, 10th Floor, Shell House, 9 Riebeeck Street, Cape Town.
- C754/84/4A—**Lubbe Dienssentrum (Edms.) Bpk.**, in liquidation. 22/9/87. To pay dividends. A. W. Bosch and E. B. Wallace, c/o Southern Cape Trust, Van Kervel House, 117 York Street, George.
- B751/86—**Van Aardt**, J. P. S. Eerste en Finale Likwidasië en Distribusie. 28 September 1987. Dividend is betaalbaar aan konkurrente skuldeisers. H. J. F. Steyn, Posbus 819, Bloemfontein.
- B556/86—**Walter**, Leslie John, tydens sekwestrasie woonagtig te Werdasingel 37, Uitsig, Bloemfontein en handeldrywende as SA Caravan Conversions, Bloemfontein. 21/9/87. Preferente dividende en kontribusie betaalbaar. C. J. Venter, p/a Naudes, Posbus 153, Bloemfontein.
- E111/86—**Dreyer**, Casparus Johannes Reinardus, who traded as Model Motors, Impala Cafe, Amanda Motors and BSG Winkels at Burgersdorp. 17 September 1987. Equalising and concurrent dividends being paid. Andrew Stuart Paterson and Kenneth Norman Paterson, Third Floor, CNA Building, 37 Union Street, East London.
- C12/86/2A—**Wholesale Retail Furnishers (Maitland) (Pty) Ltd**, in liquidation. 29 September 1987. Equalising dividend only. Stephen Malcolm Gore and Ernest David James, c/o Sanek Cape (Pty) Ltd, Ninth Floor, Greenmarket Place, 54 Shortmarket Street, Cape Town, 8001.
- C499/86—**Kasner**, Henry James. 22 September 1987. Dividend payable. S. M. Gore and E. D. James, c/o Sanek Cape (Pty) Ltd, Greenmarket Place, Shortmarket Street, Cape Town, 8000.
- T1751/86—**Grabie**, J. J. 28/9/87. Uitkeer van dividende. N. H. Boezaart, Posbus 2205, Pretoria.
- T1925/86—**Loupls**, Anastasios. 18/9/87. Contribution levied. Farrel Wainer, c/o P.O. Box 9460, Johannesburg, 2000.
- B392/86—**Du Toit**, Carel Stephanus Johannes Herbst, wie tydens sekwestrasie woonagtig was te Victoriastraat 10, Winburg. 14/8/87. Preferente dividende. F. R. R. Neethling, p/a Naudes, Posbus 153, Bloemfontein.
- B591/86—**Roberts**, Ronald. First and Final Liquidation and Distribution. 5 October 1987. Dividends payable to preferent creditors only. H. J. F. Steyn, P.O. Box 819, Bloemfontein.
- B388/86—**De Klerk**, J. M. 21 September 1987. Dividende uitgekeer word. E. F. Saffy, Posbus 27, Bloemfontein.
- B534/86—**Griessel**, Hendrik Jacobus. 15 September 1987. Dividende word uitgekeer. E. F. Saffy, p/a Siebert & Honey, Posbus 29, Bloemfontein, 9300.
- T1686/86—**Oosthuizen**, Nicolaas Jacobus, Id. No. 4610285114007. 25/9/87. Secured award. J. F. Klopper, for Syfrets Trust Ltd, P.O. Box 29980, Sunnyside, Pretoria.
- T4685/86—**Viking Tyre CC**, in liquidation. 30/9/87. Secured and preferent awards. M. Klein, for Syfrets Trust Ltd, P.O. Box 29980, Sunnyside, Pretoria.
- T1364/86—**Miller**, Pellerd Izak, and Maria Gertruida Miller. 11/9/87. Secured award. J. F. Klopper, for Syfrets Trust Ltd, P.O. Box 29980, Sunnyside, Pretoria.
- T2471/86—**Rossouw**, Michael Stephanus Antonie, Id. No. 4304155047006. 28/9/87. Secured award. S. Slot, for Syfrets Trust Ltd, P.O. Box 29980, Sunnyside, Pretoria.
- T1154/86—**Knoesen**, Guillaume du Plessis, Id. No. 4710125034009. 28/9/87. Preferent and secured awards. E. D. James, for Syfrets Trust Ltd, P.O. Box 29980, Sunnyside, Pretoria.

- T1767/84—**Gene's Refrigeration & Air Conditioning**, in liquidation. 29/9/87. Contribution levied. E. D. James, for Syfrets Trust Ltd, P.O. Box 29980, Sunny side, Pretoria.
- E84/85—**James**, Noel David, formerly trading as Timber Town Industries, Timber Town Charcoal at Stutterheim and Dads at King William's Town. 17 September 1987. Dividend being paid. D. A. Morris, for East Cape Trustees CC, AA House, Rink Street, Port Elizabeth.
- E326/86/2B—**Du Plessis**, Petrus Johannes Christoffel, formerly residing at 340 Main Road, Charlo, Port Elizabeth. 17 September 1987. Preferent or secured and concurrent. D. A. Morris, for East Cape Trustees CC, AA House, Rink Street, Port Elizabeth.
- N250/86—**Ballito Agencies (Pty) Ltd**, in liquidation. 21/9/87. A dividend will be paid. J. A. Bruce, c/o Metboard (Natal) Ltd, Fourth Floor, Federated Insurance House, 320 Smith Street, 4001; B. L. Kurz, c/o Errol W. Stowell & Co., P.O. Box 33, Pietermaritzburg and I. L. Whiteford, c/o Coopers & Lybrand, P.O. Box 1945, Durban.
- N467/86—**Kings Wholesalers (Pty) Ltd**, in liquidation. 21/9/87. A contribution will be levied. M. J. Ensor & Miss G. L. Warricker, c/o Metboard (Natal) Ltd, Fourth Floor, Federated Insurance House, 320 Smith Street, Durban, 4001.
- B752/85—**Smit**, Jacobus Arthur, handeldrywende as F & J Parts & Canopy Centre, Murrystraat 58, Kroonstad, 9500. 28/9/87. Dividende uitgekeer. G. F. Wessels, p/a Symington & De Kok, Posbus 760, Bloemfontein, 9300.
- T2434/85 4B—**Agents Fidelity Fund Ltd**, in voluntary liquidation. 17/9/87. Dividend paid. R. W. Killops, P.O. Box 8813, Johannesburg, 2000.
- C118/87/3B—**Seasound (Pty) Ltd**, in voluntary liquidation. 21 September 1987. Dividend being paid. Robin Grieve Campbell, 19th Floor, Old Mobil House, 2 Long Street, Cape Town, 8001.
- B343/86—**Welkom Civil Engineering Services (Edms.) Bpk.**, in likwidasie. Tweede en Finale Likwidasie en Distribusie. 28/9/87. Uitkeer van dividende. John Werner Wessels, Posbus 721, Welkom.
- T1477/82—**De Villiers**, Basil Chalmers, born on 23/9/38, Reg. No. 87/02814/23. Second and Final Liquidation and Contribution. 28/9/87. Contribution being levied. C. P. van Zyl, c/o Progressive Administration & Management CC, P.O. Box 1183, Randburg, 2125.
- T1943/85—**Dutfou Excavators (Pty) Ltd**, in liquidation, Reg. No. 87/02814/23. First and Final Liquidation and Contribution. 29/9/87. Contribution being levied. C. P. van Zyl, c/o Progressive Administration & Management CC, P.O. Box 1183, Randburg, 2125.
- T2375/86—**Malan**, Fiona Sheila, formerly trading as Kitchens Unlimited, Id. No. 5802280013006, Reg. No. 87/02814/23. First Liquidation and Distribution. 24/9/87. Award to secured creditors. C. P. van Zyl, c/o Progressive Administration & Management CC, P.O. Box 1183, Randburg, 2125.
- T1025/86—**Dofri Foods (Pty) Ltd**, in liquidation, Reg. No. 87/02814/23. First Liquidation and Distribution. 24/9/87. Award to secured creditor only. C. P. van Zyl & N. Bowman, c/o Progressive Administration & Management CC, P.O. Box 1183, Randburg, 2125.
- T774/85—**Miller**, Nigel Gerard, formerly trading as Pricerite Shoes & Ideal Shoes, born on 20/10/42, Reg. No. 87/02814/23. Revised Second and Final Liquidation and Distribution. 29/9/87. Award to preferent creditor only. C. P. van Zyl, c/o Progressive Administration & Management CC, P.O. Box 1183, Randburg, 2125.
- T868/86—**International Multiple Marketing (Pty) Ltd**, in liquidation, Reg. No. 87/02814/23. Revised First Liquidation and Distribution. 28/9/87. Award to certain preferent and secured creditors only. C. P. van Zyl & N. Bowman, c/o Progressive Administration & Management CC, P.O. Box 1183, Randburg, 2125.
- T1356/85—**Afro TV & Film Productions (Pty) Ltd**, in liquidation, Reg. No. 87/02814/23. Second and Final Liquidation and Distribution. 29/9/87. Award to creditors and contributories. C. P. van Zyl, c/o Progressive Administration & Management CC, P.O. Box 1183, Randburg, 2125.
- T92/83—**Sutherland**, Alistair. Second and Final Liquidation and Distribution. 22/9/87. Awards to certain preferent and secured creditors only. S. Trakman & J. G. R. Seagers, c/o Highveld Trust & Management CC, P.O. Box 10463, Johannesburg, 2000.
- B594/86—**Spies**, Jan Jacobus, van Vaalwater Boerdery, Parys. 29/9/87. Uitkeer dividende. Roelof Davel du Plessis, Posbus 760, Bloemfontein, en Frederick Ryk Rudolph Neethling, Posbus 153, Bloemfontein.
- T3756/85—**Kirson Investments (Pty) Ltd**, in voluntary liquidation. 22/9/87. Dividend being paid. S. Janit, P.O. Box 1523, Johannesburg, 2000.
- C1260/85—**Instant Portrait Systems (Pty) Ltd**, in likwidasie. 22 September 1987. Dividend payable. E. B. Wallace, for Sanek Cape (Pty) Ltd, Greenmarket Place, Shortmarket Street, Cape Town.
- C430/86—**Debisa (Pty) Ltd**, in likwidasie. 28 September 1987. Dividend payable and contribution levied. E. B. Wallace, for Sanek Cape (Pty) Ltd, Greenmarket Place, Shortmarket Street, Cape Town, 8000.
- C1216/85—**Evomar CC**, in voluntary liquidation. 22/9/87. Dividend being paid and Contribution being collected. S. Gutman, Group Administrators & Trustees (Pty) Ltd, P.O. Box 4961, Cape Town.
- C157/85—**Hattingh**, J. D. First and Final Liquidation and Distribution. 17 September 1987. Dividend being paid. M. T. East and J. J. K. Lappchen, 140 St George's Street, 8001, Cape Town.
- C342/78—**Rooderust (Pty) Ltd**, in liquidation. 17 September 1987. Dividend being paid. D. J. Rennie, 140 St George's Street, Cape Town, 8001.
- C387/84—**Mossel River Holdings (Pty) Ltd**, in voluntary liquidation. 15 September 1987. Dividend being paid. D. J. Rennie & J. K. Lappchen, 140 St George's Street, Cape Town.
- C888/86/4B—**Renate Hair Design (Pty) Ltd**, in liquidation. 25 September 1987. Both. Don Samuel Ozinsky, c/o Sanek Cape (Pty) Ltd, Ninth Floor, Greenmarket Place, 54 Shortmarket Street, Cape Town, 8001.
- E374/86—**Minnaar**, Norman, who resided at 7 Half Moon Crescent, Dorchester Heights, East London. 25 September 1987. Preferent award being paid. Andrew Stuart Paterson & Kenneth Norman Paterson, Third Floor, CNA Building, 37 Union Street, East London.
- E302/86—**Bolton**, Aubrey Velden, who traded as Carousel at 83a Old Transkei Road, Nahoon, East London. 25 September 1987. Secured award being paid and contribution being collected. Andrew Stuart Paterson & Kenneth Norman Paterson, Third Floor, CNA Building, 37 Union Street, East London.
- E35/86—**Ranger**, John Morris, who traded as Ranger Construction at Morgan Bay and Kei Mouth. 25 September 1987. Secured award being paid and contribution being collected. Andrew Stuart Paterson & Kenneth Norman Paterson, Third Floor, CNA Building, 37 Union Street, East London.
- E20/81—**Butler**, Peter Owen, who farmed at Caprice in the District of East London. 25 September 1987. Concurrent dividends being paid. Kenneth Norman Paterson, Third Floor, CNA Building, 37 Union Street, East London.
- T36/86—**Parktown Medical Properties Ltd**, in liquidation. 17/9/87. Dividend being paid. Trevor Richard Franklin, c/o Coopers & Lybrand Trust (Pty) Ltd, P.O. Box 139, Johannesburg, 2000.
- T1620/85—**Double J Farming Enterprises (Pty) Ltd**, in liquidation, Registration Number 80/00915/07. Amended Third and Final. 21/9/87. Concurrent, preferent, secured and equalising awards being paid. J. H. Bliognaut and P. J. E. Meintjes, c/o Metrust Ltd, P.O. Box 32225, Braamfontein, 2017.
- 35/86—**Park Lane Medical Holdings (Pty) Ltd**. 15/9/87. Dividends being paid. Trevor Richard Franklin, c/o Coopers & Lybrand Trust (Pty) Ltd, P.O. Box 139, Johannesburg, 2000.
- T3992/86—**Bryanston Drive Properties (Pty) Ltd**. 8/9/87. Dividends being paid. Trevor Richard Franklin, c/o Coopers & Lybrand Trust (Pty) Ltd, P.O. Box 139, Johannesburg, 2000.
- T34/86—**Park Lane Clinic for Women (Pty) Ltd**. 17/9/87. Dividends being paid. Trevor Richard Franklin, c/o Coopers & Lybrand Trust (Pty) Ltd, P.O. Box 139, Johannesburg, 2000.
- T1867/86—**Pretorius**, C. E. Eerste en Finale Likwidasie en Verdelings vir die tydperk 5/5/86 tot 31/8/86. 25/9/87. Dividend betaalbaar. P. D. Kruger, p/a Cape Trustees Bpk., Ou Mutualsentrum 905, Andriesstraat 167, Pretoria, 0001.
- C711/86—**Van der Nest**, A. M. 26/9/87. Dividende. D. J. Strauss, vir Malan Trust, Posbus 202, Joubertina, 6410.
- T1036/86—**Dalhouzie**, Johan Louis Petrus. Eerste en Finale Likwidasie en Distribusie. 30/9/87. Dividende word uitgekeer. W. Hogewind, Posbus 5123, Horison, 1730.
- T2039/86—**Abrahams**, Herman Mark. 25/9/87. Award to secured creditors. V. A. van Diggelen, for Limvaal Trustees, P.O. Box 3548, Pretoria.

- T3198/86—**Clark, Robert James**. 24/9/87. Award to secured creditors. V. A. van Diggelen, for Limvaal Trustees, P.O. Box 3548, Pretoria.
 T8/83—**Grobler, Arnestus Stephanus Christoffel**. 24/9/87. Award to creditors. V. A. van Diggelen, for Limvaal Trustees, P.O. Box 3548, Pretoria.
 T3911/86—**Steenkamp, Johannes Willem Horn**. 25/9/87. Award to secured creditors. V. A. van Diggelen, for Limvaal Trustees, P.O. Box 3548, Pretoria.
- T2430/86—**Beukes, Viententia Leenard**, formerly trading as Vera Modes. 29/9/87. Award to preferent creditors. V. A. van Diggelen, for Limvaal Trustees, P.O. Box 3548, Pretoria.
 T4455/86—**Forsyth, Peter Traill Forbes**. 25/9/87. Award to secured creditors. V. A. van Diggelen, for Limvaal Trustees, P.O. Box 3548, Pretoria.
 T240/85—**Nimrah Engineering (Pty) Ltd**, in liquidation. 29/9/87. Award to preferent creditors. V. A. van Diggelen, for Limvaal Trustees, P.O. Box 3548, Pretoria.
- T2134/82—**King David Investments (Pty) Ltd**, in voluntary liquidation, Company Number 57/02793/07. 21/8/87. Dividend being paid. Neil Rissik, 12th Floor, J.C.I. House, 28 Harrison Street, Johannesburg.
 T1834/83—**Shapersum (Pty) Ltd**, in voluntary liquidation, Company Number 57/02941/07. 20/7/87. Dividend being paid. Neil Rissik, 12th Floor, J.C.I. House, 28 Harrison Street, Johannesburg.
 T2347/86/7B—**DEC Investments (Pty) Ltd**. 1987-09-28. Return of capital. Alan Brener, c/o The Druker Trust (Pty) Ltd, P.O. Box 9740, Johannesburg.
 T2545085/5A—**Van den Akker, Johannes Josephus Franciscus**. 1987-09-30. Dividend being paid. Alan Brener, c/o The Druker Trust (Pty) Ltd, P.O. Box 9740, Johannesburg.
 T1873/85/3A—**Venter, Christoffel Morkel**. 1987-10-01. Dividend being paid. Alan Brener, c/o The Druker Trust (Pty) Ltd, P.O. Box 9740, Johannesburg.
- T3455/86—**Media Productions (Pty) Ltd**, in liquidation. 28/9/87. No award. Julius Hirshberg, P.O. Box 10527, Johannesburg.
 T1488/86—**Intradco (Pty) Ltd**, in liquidation. 25/9/87. Secured and preferent award. Neil Bowman, P.O. Box 10527, Johannesburg.
 T1424/86—**Cillier, R. J. J.** 24/9/87. Secured and preferent award. Neil Bowman, P.O. Box 10527, Johannesburg.
 T3793/85—**DA Construction (Pty) Ltd**, in liquidation. 23/9/87. Secured award. Leslie Cohen and P. D. Berman, P.O. Box 10527, Johannesburg.
 T841/86—**Vagos Marketing (Pty) Ltd**. 28/9/87. Dividend being paid and contribution levied. M. K. Hyslop, P.O. Box 2186, Johannesburg.
 T288/82—**Jones Building Services (Pty) Ltd**. 28/9/87. Dividend being paid. H. Zinman, P.O. Box 2186, Johannesburg, 2000.
 E241/85—**Taljaard, Francois**. Second Liquidation and Distribution. 18/9/87. Award being paid. Basil Kenneth Spengler van Zyl and Hermanus Maritz, for Syfrets Trust Ltd, 94 Main Street, Port Elizabeth, 6001.
 E164/83—**Ralph Trading Enterprises (Pty) Ltd**, in liquidation. Second and Final Liquidation and Distribution. 23/9/87. Award being paid. Basil Kenneth Spengler van Zyl, for Syfrets Trust Ltd, 94 Main Street, Port Elizabeth, 6001.
 E123/86—**Potgieter, J. M.** First and Final Liquidation and Distribution. 18/9/87. Award being paid. Basil Kenneth Spengler van Zyl and Hermanus Maritz, for Syfrets Trust Ltd, 94 Main Street, Port Elizabeth, 6001.
 E345/85—**Stoltz, Leon Benoni**, formerly trading as Prestige Body Works and Unique Body Works. First and Final Liquidation and Distribution. 18/9/87. Award being paid. Basil Kenneth Spengler van Zyl and Hermanus Maritz, for Syfrets Trust Ltd, 94 Main Street, Port Elizabeth, 6001.
 E189/86—**Le Roux, Johan**. First and Final Liquidation and Distribution. 23/9/87. Award being paid. Basil Kenneth Spengler van Zyl and Hermanus Maritz, for Syfrets Trust Ltd, 94 Main Street, Port Elizabeth, 6001.
 T2821/86—**Marais, R.** First and Final Liquidation and Contribution. 3/9/87. G. H. J. Venter, P.O. Box 1474, Johannesburg, 2000.
 T2780/86—**Osman, I. M. R.** First and Final Liquidation and Distribution. 30/9/87. G. H. J. Venter, P.O. Box 1474, Johannesburg, 2000.
 T3289/85—**Tricia Kitchens (Pty) Ltd**. First and Final Liquidation and Distribution and Contribution. 29/9/87. G. H. J. Venter, P.O. Box 1474, Johannesburg, 2000.
 T1815/86—**Container Freight Internal (Pty) Ltd**. 17 September 1987. Award to secured and concurrent creditors only. Theo Tromp, c/o Central Trust CC, P.O. Box 6126, Johannesburg, 2000.
 N129/86—**Fontenay (Pty) Ltd**. 1/9/87. Dividend payable. A. D. Wilkins, c/o Deloitte Haskins & Sells Trust (Pty) Ltd, P.O. Box 1009, Johannesburg.
- T1094/84—**Solarson (Pty) Ltd**. 17/9/87. Dividend payable. I. Bekker, c/o Deloitte Haskins & Sells Trust (Pty) Ltd, P.O. Box 1009, Johannesburg.
 T2899/86—**Zieglmeiers (Pty) Ltd**. 28/9/87. Dividends payable. I. Bekker, c/o Deloitte Haskins & Sells (Pty) Ltd, P.O. Box 1009, Johannesburg.
 T4079/85—**Dormannt Holdings (Pty) Ltd**. 22/9/87. Dividend payable. M. L. de Villiers, c/o Deloitte Haskins & Sells Trust (Pty) Ltd, P.O. Box 1009, Johannesburg, 2000.
 T2484/86—**The House of Eloo (Pty) Ltd**, in liquidation. First Liquidation and Distribution. 17 September 1987. Dividend being paid. Mervyn I. Swartz, for Rand Board of Trustees, P.O. Box 308, Johannesburg, 2000.
 T341/87—**M & M Timbers C.C.**, in liquidation. First Liquidation and Distribution. 24 September 1987. Dividend being paid. Mervyn I. Swartz, for Rand Board of Trustees, P.O. Box 308, Johannesburg, 2000.
 T114/86—**Botha, Johannes**. First and Final Liquidation, Distribution and Contribution. 17 September 1987. Dividend being paid and contribution levied. Mervyn I. Swartz, for Rand Board of Trustees, P.O. Box 308, Johannesburg, 2000.
 T3385/85—**Van Aswegen, F. J. C.** Eerste Likwidasie en Verdelings. 25/9/87. Dividende aan versekerde skuldeisers. P. D. Kruger en B. G. Smit, p/a Cape Trustees Bpk., Ou Mutualsentrum 905, Andriesstraat 167, Pretoria, 0001.
 T3437/85—**Rasmussen, R. A.** Eerste en Finale Likwidasie en Verdelings. 28/9/87. Dividend betaalbaar. P. D. Kruger, p/a Cape Trustees Bpk., Ou Mutualsentrum 905, Andriesstraat 167, Pretoria, 0001.
 T2000/85—**McCullough, E.** Eerste en Finale Likwidasie, Verdelings en Kontribusie. 30/9/87. Kontribusie betaalbaar. J. H. van Rensburg, p/a Cape Trustees Bpk., Ou Mutualsentrum 905, Andriesstraat 167, Pretoria, 0001.
 T2894/86—**Action Promotional Services (Edms.) Bpk.**, in likwidasie. Eerste en Finale Likwidasie en Verdelings. 24/9/87. Dividend betaalbaar. J. H. van Rensburg, p/a Cape Trustees Bpk., Ou Mutualsentrum 905, Andriesstraat 167, Pretoria, 0001.
 T1472/86—**Potgieter, J. D.** Eerste Likwidasie en Verdelings. 25/9/87. Dividend betaalbaar aan voorkeur skuldeisers. Paul D. Kruger, p/a Cape Trustees Bpk., Ou Mutualsentrum 905, Andriesstraat 167, Pretoria, 0001.
 T1176/85—**Pretoria Uitrusters (Edms.) Bpk.**, in likwidasie. Eerste en Finale Likwidasie en Verdelings. 25/9/87. Dividende betaalbaar. J. H. van Rensburg, p/a Cape Trustees Bpk., Ou Mutualsentrum 905, Andriesstraat 167, Pretoria, 0001.
 T2385/85—**Radioff, M. P. A.** Tweede en Finale Likwidasie en Verdelings. 17/9/87. Dividend betaalbaar. J. H. van Rensburg, p/a Cape Trustees Bpk., Ou Mutualsentrum 905, Andriesstraat 167, Pretoria, 0001.
 T2176/86—**Pietersburg Melkerye (Edms.) Bpk.**, in likwidasie. Eerste en Finale Likwidasie en Verdelings. 29/9/87. Dividende aan voorkeur en versekerde skuldeisers. J. H. van Rensburg en S. Rossouw, p/a Cape Trustees Bpk., Ou Mutualsentrum 905, Andriesstraat 167, Pretoria, 0001.
 T1607/86—**Grey, F. T.** Eerste Likwidasie en Verdelings. 29/9/87. Dividende betaalbaar aan preferente skuldeisers. P. D. Kruger en A. J. Hessels, p/a Cape Trustees Bpk., Ou Mutualsentrum 905, Andriesstraat 167, Pretoria, 0001.
 C444/86—**Drake, Alexander William**. First and Final Liquidation and Distribution. 30/9/87. Dividends being paid. E. D. James, for Republiek Trustees (Pty) Ltd, P.O. Box 4300, Cape Town.
 C1143/85/3B—**De Kulen Motors (Edms.) Bpk.**, in likwidasie. 17 Julie 1987. L. Smit, Bostonstraat-Een 901, Bellville, 7530.
 T1269/86—**Louw, J. A. W.** 29/9/87. Konkurrente dividend. C. J. Uys, vir Trust Validus, Posbus 36216, Menlo Park, 0102.
 T889/86—**Smith, M. G.** 25/9/87. Kontribusie. C. J. Uys, vir Trust Validus, Posbus 36216, Menlo Park, 0102.
 T674/86—**Du Preez, P. J.** 7/7/87. Preferente dividend en kontribusie. C. J. Uys, vir Trust Validus, Posbus 36216, Menlo Park, 0102.

- N141/86—**Roberts, T. P.** 7/9/87. Dividend paid, contribution levied. R. J. Strydom, c/o Natal Trust Company (Pty) Ltd, P.O. Box 5342, Durban, 4000.
- N402/86—**Ongers, M. R.** 16 September 1987. Dividend being paid. K. D. Krumm, c/o Syfrets Trust Ltd, P.O. Box 135, Durban, 4000.
- N818/85—**Chennels, A. J.** 11 September 1987. Contribution levied. K. D. Krumm, c/o Syfrets Trust Ltd, P.O. Box 135, Durban, 4000.
- N445/85—**De Jager, V.** 14 September 1987. Dividends being paid. G. B. Perry, c/o Syfrets Trust Ltd, P.O. Box 135, Durban, 4000.
- N218/85—**Terry Clothing Manufacturers (Pty) Ltd**, members' voluntary winding-up. 11 September 1987. Award to shareholders. K. D. Krumm, c/o Syfrets Trust Ltd, P.O. Box 135, Durban, 4000.
- N704/85—**Hendrikse, J. P. S.** 17 September 1987. Secured and preferent awards only. G. B. Perry, c/o Syfrets Trust Ltd, P.O. Box 135, Durban, 4000.
- N77/87—**Hunt, C. F.** 30 June 1987. Secured award only. G. B. Perry, c/o Syfrets Trust Ltd, P.O. Box 135, Durban, 4000.
- N565/85—**Fullco (Pty) Ltd**, in liquidation. 11 September 1987. Concurrent awards only. K. D. Krumm and J. A. Bruce, c/o Syfrets Trust Ltd, P.O. Box 135, Durban, 4000.
- N61/82—**Fred Smith Motors (Pty) Ltd**, in liquidation. 23/9/87. Dividend paid. R. J. Strydom, c/o Natal Trust Company, P.O. Box 5342, Durban, 4000.
- N99/85—**Kempler Construction (Pty) Ltd**, in liquidation. 21 September 1987. Preferent award only. B. P. Vermaak, c/o Syfrets Trust Ltd, P.O. Box 135, Durban, 4000.
- N194/86—**Tuskers (Pty) Ltd**, in voluntary liquidation. 11 September 1987. Dividend being paid. Stephen Ian Perling, 301 Durban Bay House, 333 Smith Street, Durban.
- N413/86—**Oscos Services (Pty) Ltd**. 23/9/87. Dividend. M. A. Bullough, c/o Probitas Trust & Finance Co. (Pty) Ltd, 29 Jesmond Grove, Overport, 4001.
- T3094/85—**Venture Refinery (Pty) Ltd**. 1987-09-18. Dividend. F. G. Gay, c/o Felix Gay Trust (Pty) Ltd, P.O. Box 260404, Excom, 2023.
- T2924/86 4B—**Katz, G. M.** 1987-09-25. Dividend. F. G. Gay, c/o Felix Gay Trust (Pty) Ltd, P.O. Box 260404, Excom, 2023.
- T1569/86—**Wild Thistle Investments (Pty) Ltd**. Supplementary Liquidation and Distribution. 28/9/87. G. H. J. Venter, P.O. Box 1474, Johannesburg.
- T2785/86—**Vermeulen, J. M.** First and Final Liquidation and Distribution. 29/9/87. G. H. J. Venter, P.O. Box 1474, Johannesburg, 2000.
- T3305/86—**Plotkin, M.** First and Final Liquidation and Contribution. 29/9/87. G. I. Smit, P.O. Box 1474, Johannesburg, 2000.
- T4313/86—**All Accessories (Pty) Ltd**. First and Final Liquidation and Contribution. 29/9/87. G. H. J. Venter, P.O. Box 1474, Johannesburg, 2000.
- T3674/86—**Algranti, V.** First and Final Liquidation and Contribution. 24/9/87. G. H. J. Venter, P.O. Box 1474, Johannesburg, 2000.
- T3088/86—**Life Insurance Brokers (Pty) Ltd**. First and Final Liquidation and Contribution. 25/9/87. G. H. J. Venter, P.O. Box 1474, Johannesburg, 2000.
- T1187/86—**River Square Dry Cleaners (Pty) Ltd**. First and Final Liquidation and Contribution. 25/9/87. G. H. J. Venter, P.O. Box 1474, Johannesburg, 2000.
- T2459/86—**Parys Wire Industries (Pty) Ltd**. First and Final Liquidation and Contribution. 23/9/87. G. H. J. Venter, P.O. Box 1474, Johannesburg, 2000.
- B66/86—**Maritz, J.** Supplementary First and Final Liquidation and Distribution. 22 September 1987. Dividends are payable to preferent creditors. H. J. F. Steyn, P.O. Box 819, Bloemfontein.
- T491/87—**Railis Properties (Pty) Ltd**. 29/9/87. Dividend being paid. A. Nankin, P.O. Box 51007, Raedene, 2124.
- T2142/86—**Duncan, R. S.** 28/9/87. Uitkeer van dividende. B. G. S. de Wet, Posbus 16185, Doornfontein.
- T2219/85—**T D L Painting Contractors (Edms.) Bpk.**, in likwidasie. 23/9/87. Uitkeer van dividende. J. R. Galloway, Posbus 16185, Doornfontein.
- T3049/85—**Hadden, A. R. en C. J. Hadden**. 28/9/87. Kontribusie te vorder. J. R. Galloway, Posbus 16185, Doornfontein.
- T178/86—**Botha, S. P.** 28/9/87. Uitkeer van dividende. B. G. S. de Wet, Posbus 16185, Doornfontein.
- T1396/86—**Potgieter, J. J.** Eerste en Finale Likwidasie en Kontribusie. 25/9/87. Dividende aan versekerde skuldeisers kontribusie aan konkurrente skuldeisers. J. S. Venter, p/a Republiek Trustees, Posbus 3410, Pretoria, 0001.
- T3157/85—**Hearne, B. S.** Eerste en Finale Likwidasie en Distribusie. 28/9/87. Dividende aan preferente skuldeisers. D. H. Rheeder, p/a Republiek Trustees, Posbus 3410, Pretoria, 0001.
- T2861/84—**Hakos Meubelmakers (Edms.) Bpk.** 25/9/87. Dividende aan konkurrente skuldeisers. J. N. Bekker, p/a Republiek Trustees, Posbus 3410, Pretoria, 0001.
- T3528/85—**Swarts, L. E.** Eerste en Finale Likwidasie en Verdeling. 19/9/87. Dividende aan versekerde, preferente en konkurrente skuldeisers. J. S. Venter, p/a Republiek Trustees, Posbus 3410, Pretoria, 0001.
- T3230/85—**Middelburg Kons. Edms. Bpk.**, in likwidasie. 2/10/87. Dividend. H. J. T. Eloff, p/a Lektor Trust, Posbus 1712, Randburg, 2125.
- T3427/85—**Gouws, L. J.** Tweede en Finale Likwidasie en Distribusie. 7/10/87. Dividend. H. J. T. Eloff, p/a Lektor Trust, Posbus 1712, Randburg, 2125.
- T3655/86—**Dannhauser, George Frederick**. 28 September 1987. Kontribusie ingevorder. A. V. Hamman, Posbus 13948, Sinoville, 0129.
- T4149/86—**Cloete, M. H.** First Liquidation and Distribution. 29/9/87. Secured dividends. T. A. P. du Plessis, c/o Aiken & Carter Administrators (Pty) Ltd, P.O. Box 61323, Marshalltown, 2107.
- T2967/86—**Comined Plumbers (Pty) Ltd**, in liquidation. First and Final Liquidation and Distribution. 9/10/87. Preferent and concurrent dividends. D. S. Hoare, c/o Aiken & Carter Administrators (Pty) Ltd, P.O. Box 61323, Marshalltown, 2107.
- T4152/85—**Car Wars Metallic Spray Painters & Panelbeaters**. 4/8/87. No dividend being paid. B. B. Nel, 527 Prudential Assurance Building, 28 Church Square, Pretoria.
- T2296/86—**Vos, C. J.** 22/9/87. No dividend being paid. B. B. Nel, 527 Prudential Assurance Building, 28 Church Square, Pretoria.
- T2675/86—**Hamilton Printers (Pty) Ltd**. First Liquidation and Distribution. 25/9/87. P. W. M. Reynolds, c/o Arthur Young Trust & Management Co. (Pty) Ltd, 15th Floor, Main Central, 112 Main Street, Johannesburg.
- T4346/86—**Fourie, Jacoba Margaretha**. Eerste en Finale Likwidasie en Kontribusie. 30/9/87. Matthew Klein, Klein-Slot Trustees, Posbus 5437, Pretoria, 0001.
- B538/86—**Janse van Vuuren, R. P.** 8/10/87. Dividende uitgekeer. T. L. Naudè, p/a Naude, Thompson & De Bruyn, Reitzstraat 23, Posbus 932, Kroonstad.
- C1156/85—**Stromboli Clothing (Pty) Ltd**, in liquidation. 25/9/87. Dividend being paid. B. W. Smith, E. B. Wallace, c/o Cape Trustees Ltd, 2 Long Street, Cape Town.
- C48/86—**Schaap, C. M. A.** 23/9/87. Both. B. W. Smith, c/o Cape Trustees Ltd, 2 Long Street, Cape Town.
- C790/86—**Maglen Motors (Pty) Ltd**, in liquidation. 25/9/87. Dividend being paid. B. W. Smith, c/o Cape Trustee Ltd, 2 Long Street, Cape Town.
- C581/86—**Marais, D. F.** 26/9/87. Dividend being paid. B. W. Smith, c/o Cape Trustees Ltd, 2 Long Street, Cape Town.
- C640/86—**Expo Meubeleerders (Kulsvrivler) (Edms.) Bpk.**, in liquidation. 24/9/87. Dividend being paid. L. v. W. Bester, c/o Cape Trustees Ltd, 2 Long Street, Cape Town.
- C270/84—**Tisaker, N.** 25/9/87. Dividend being paid. R. Millman, J. N. Bekker, c/o Cape Trustees Ltd., 2 Long Street, Cape Town.
- C338/86—**Bosch, J. H.** 23/9/87. Dividend being paid. L. v. W. Bester, c/o Cape Trustees Ltd., 2 Long Street, Cape Town.
- C463/86—**Lorenzi, Giovanni Andriano**. 23/9/87. Dividend being paid. R. Millman, c/o Cape Trustees Ltd., 2 Long Street, Cape Town.
- C336/86—**Malherbe, A. L.** 24/9/87. Secured award. J. J. Rousseau, c/o Cape Trustees Ltd, 2 Long Street, Cape Town.
- C811/86—**Kimlin (Pty) Ltd**, in liquidation. 25/9/87. Dividend being paid. F. D. Glaum, c/o Cape Trustees Ltd, 2 Long Street, Cape Town.

- T2824/86—**Purves, J. W. A.** 1/10/87. A dividend is being paid. P. J. E. Meintjes, P.O. Box 1408, Florida, 1710.
 T140/86—**Mac Holdings (Pty) Ltd.** 30/9/87. A dividend is being paid. P. J. E. Meintjes, P.O. Box 1408, Florida, 1710.
 T1516/86—**Steenkamp, J. N.** Eerste en Finale. 29/9/87. Versekerde toekennings. J. H. van Blerk, p/a Metboard (Pta) Bpk., Posbus 3127, Pretoria.
 T2291/86—**Swanepoel, J. K.** Tweede en Finale. 29/9/87. Versekerde toekennings. A. J. Hessels, p/a Metboard (Pta) Bpk., Posbus 3127, Pretoria.
 T1355/86—**Eland Footwear Manufacturers (Pty) Ltd**, in liquidation. 28/9/87. Dividend being paid. D. J. Rennie, c/o Syfrets Trust Ltd, P.O. Box 61058, Marshalltown, 2107.
 T677/85—**European and Eastern Trading Company (Pty) Ltd**, in liquidation. 28/9/87. Dividend being paid. D. J. Rennie, c/o Syfrets Trust Ltd, P.O. Box 61058, Marshalltown, 2107.
 T1878/85—**Cyril Hurvitz Export Co. (Pty) Ltd**, in liquidation. 28/9/87. Dividend being paid. D. J. Rennie & A. Ruskin, c/o Syfrets Trust Ltd, P.O. Box 61058, Marshalltown, 2107.
 T2611/85—**Nel, L. P. en K. H. C. Nel.** 29/9/87. Award to secured creditors and contribution being levied. D. J. Rennie, c/o Syfrets Trust Ltd, P.O. Box 61058, Marshalltown, 2107.
 T2909/86—**Archon Trading (Pty) Ltd**, in liquidation. 28/9/87. No dividend being paid. D. J. Rennie, c/o Syfrets Trust Ltd, P.O. Box 61058, Marshalltown, 2107.
 T2680/85—**House of Tiles (Pty) Ltd**, in liquidation. 30/9/87. Award to secured creditors. D. J. Rennie, c/o Syfrets Trust Ltd, P.O. Box 61058, Marshalltown, 2107.
 T2718/86—**Stoffels Excavators (Edms.) Bpk.**, in likwidasie. 24 September 1987. T. C. Muller, Posbus 1990, Pretoria.
 T1673/86—**Grobler, C. J.** 1 Oktober 1987. Konkurrente dividend. T. C. Muller, Posbus 1990, Pretoria.
 T1893/86—**Van der Merwe, F.** 1 Oktober 1987. Versekerde dividend. L. Klopper, Posbus 1990, Pretoria.
 T1937/86—**Smit, L. W.** 30 September 1987. Voorkeur en konkurrente dividend. T. C. Muller, Posbus 1990, Pretoria.
 T313/86—**Jordaan, C. O.** 1 Oktober 1987. Kontribusie ingevorder. T. C. Muller, Posbus 1990, Pretoria.
 T607/85—**Van Biljon, J. A.** 30 September 1987. Voorkeur en konkurrente dividend. T. C. Muller, Posbus 1990, Pretoria.
 T969/85—**Geldenhuis, G. P.** Suplementêre. 29/9/87. Voorkeur en konkurrente toekennings. A. J. Hessels, p/a Metboard (Pta) Bpk., Posbus 3127, Pretoria.
 T1660/85—**Astra Business Machines (Pty) Ltd**, in likwidasie. Suplementêre. 30/9/87. Konkurrente Toekennings. A. J. Hessels, p/a Metboard (Pta) Bpk., Posbus 3127, Pretoria.
 T1208/86—**De Klerk, H. C.** Eerste. 29/9/87. Versekerde toekennings. J. H. van Blerk, p/a Metboard (Pta) Bpk., Posbus 3127, Pretoria.

Vorm/Form 6

AANSOEK OM REHABILITASIE

Ingevolge artikel 124 van die Insolvensiewet, 1936, word hierby kennis gegee dat die insolvente persone hieronder genoem om hul rehabilitasie aansoek sal doen op die datums, tye en plekke en om die redes wat daarin teenoor hulle onderskeie name aangedui is, met aanduiding van nommer van boedel; volle naam en beskrywing van insolvent (met inbegrip van sy geboortedatum en persoonsnommer) en plek van besigheid of woonplek; datum waarop boedel gesekwestreer is, en adres, betrekking of status van insolvent ten tye van daardie datum; afdeling van Hooggeregshof waarby en datum en tyd wanneer aansoek gedoen sal word; rede van aansoek.

APPLICATION FOR REHABILITATION

Pursuant to section 124 of the Insolvency Act, 1936, notice is hereby given that the insolvents mentioned below will apply for their rehabilitation on the dates, at the times and places and upon the grounds as therein set forth opposite their respective names, indicating number of estate; full name and description of insolvent (including his date of birth and identity number) and place of business or residence; date when estate sequestrated, and address, occupation or status of insolvent at the time of that date; division of Supreme Court to which and date and time on which application will be made; ground of application.

- T2356/85—**Formington, George**, 13 April 1929, 2904135020007, bestuurder, N.S. Construction and Design CC, 4 Dolweni Avenue, Boskruin, Randburg, en tans woonagtig te Gordonlaan 28, Blaigowrie, Randburg. 20 Augustus 1985, woonagtig te Gordonlaan 28, Blaigowrie, Randburg, in diens van Formington Construction Company (Edms.) Bpk., nou in likwidasie. Witwatersrandse Plaaslike, 17 November 1987, 10h00. In terme van artikel 124 (5) van die Insolvensiewet, Wet 24 van 1936, soos gewysig synde alle skuldeisers ten volle betaal.
 T894/81—**Muller, Christoffel Cornelis Arnoldus**, 10 Februarie 1939, 3902105018000, Pietersbrugstraat 56a, Ladanna, Pietersburg. 28 Julie 1981, plaas Krugerspost, distrik Lydenburg, Tvl., boukontraakteur. Transvaalse Provinsiale, 8 Desember 1987, 10h00. Artikel 124 (2) Wet 24 van 1936, tydperk versteke.
 T1380/79—**Nedeljkovic, Slavko**. 30 April 1951, 51044305479100. Fitter and turner, business: 30 Jules Street, Jeppe, Johannesburg, residence: 2 Guava Road, Primrose Extension 2. 26 September 1979, 74 17th Avenue, Edenvale, fitter and turner at MSM Engineering, 53 Leo Street, Germiston. Witwatersrand Local, 8 Desember 1987, 10h00. Section 124 (2) (a).
 B240/83—**Wells, Jacobus Johannes Scheepers**, 22 Augustus 1941, 4108225008009, bestuurder van 'n melkery te Koppies, plaas Weltevrede, Koppies, OVS. 5 September 1983. Oranje-Vrystaatse Provinsiale, 3/12/87, 10h00. Artikel 124 (2) (a) van Wet No. 24 van 1936.
 B184/81—**Stewart, Peter Stephen**, 27 Mei 1947, 475275148005, Plot Oorzaak, distrik Kroondal, Rustenburg. 17 Desember 1981. Oranje-Vrystaatse Provinsiale, 19 November 1987, 10h00. Ingevolge artikel 124 (2) (b) van die Insolvensiewet het 4 (vier) jaar verstrek.
 C537/83—**Dirmeik, Sidney**, 9 February 1938, 3802095027005, general manager employed by Efune Bros. (Pty) Ltd, 601 West Walk, Durban and resident at 104 Mountain Rise, Carrington Heights, Durban. 28 September 1983, 5 Heath Street, Newlands, Cape Town, a director of Sidney George (Pty) Ltd, Piazza Level, Golden Acre, Adderley Street, Cape Town. Cape of Good Hope Provincial, 9 December 1987, 10.00 a.m. In terms of Section 124 (2) of the Insolvency Act No. 24 of 1936.
 K50/83—**Jansen, Joachim Scholtz**, 5 Februarie 1948, 4802055153006, Analis, werkstudies tegnies, Elandstraat 16, Kathu. 2 September 1983, Van Riebeeckstraat 11, Griekwastad. Noord Kaapse, 27 November 1987, 10h00. 1. Artikel 124 (2) (a) van Wet 24 van 1936. 2. Applikant vorder 'n uitwysingsbevel met betrekking tot die opbrengs van die trust geskep in die Testament van J. P. Jansen, gedateer 23 Junie 1983, by die beëindiging van die trust.
 T1345/82—**Tripodis, Michael**, 5 September 1943, 4309055049085, 120 Kayburne Avenue, Randpark Ridge Extension 40, Randburg. 12 Oktober 1982, 10 Rhodes, Smit Street, Fairlands, Johannesburg, shopkeeper. 1 Desember 1987, 10.00 a.m., Witwatersrand Local. 124 (2) (a).
 B196/81—**Swanepoel, Barend Paulus**, 9 September 1938, 3809095056009, Rembrandtstraat 21, Sasolburg, Rubenstraat 55, Sasolburg, OVS. 19 November 1981, tans werksaam te Top Glass B.K., Patriotstraat 30, Sasolburg, bestuurder. Oranje-Vrystaatse Provinsiale, 3 Desember 1987, 10h00. In terme van Artikel 124 (2) van Wet No. 24 van 1936. Die Applikant wil weer selfstandig lewe en word gekniehalter deur die feit dat hy sy finansiële posisie nie kan verbeter nie.
 T1335/82—**Athanasellis, Miltiades**, 30/3/48, 4803305042106, an adult male, business broker, residing at 8 Tarka Road, Helderkruin, Roodepoort. 12 Oktober 1982, 8 Tarka Road, Helderkruin, Roodepoort, shopkeeper. Witwatersrand Local, 1 Desember 1987, 10.00 a.m. Section 124 (2) (a).

B189/83—**Müller, Johannes Stephanus**, 20 Februarie 1956, 5602205157009, eie staalkonstruksie, besigheid en spekulant in lewendehawe, Senator Senekalstraat 7, Viljoenskroon, OVS. 21 Julie 1983, Denyssestraat 54, Viljoenskroon, OVS, boer en besigheidsman. Oranje-Vrystaatse Provinsiale, 10 Desember 1987, 10h00. In terme van Artikel 124 (2) (a) van die Insolvensiewet No. 24 van 1936. Meer as 12 maande het verstryk vanaf die bekragtiging van die Eerste en Finale Likwidasie en Distribusie.

T1637/78—**Georghiou, Andreas**, 2/6/36, 3606025029001, supervisor, Rendezvous Hotel, Engelbrecht Street, Viljoenskroon. 3/10/78, cafe owner, previously trading as Waldorf Astoria Cafe, Naboomspruit. Transvaal Provinsiale, 1/12/87, 10h00. In terms of Section 124 (2) of Insolvency Act No. 24 of 1936.

B232/83—**Müller, Christoffel Petrus Cilliers**, 27 Augustus 1945, 4508275032009. Harkerstraat 13, Ventersburg, OVS. 1 September 1983, Blanke boer van die plaas Smaldeel, Cornelia, in die distrik Vrede, OVS. Oranje-Vrystaatse Provinsiale, 3 Desember 1987, 10h00. Artikel 124 (2) (a) van Wet 24 van 1936.

T1508/83—**Glassman, Boris**, 12 June 1923, 2306125042001, 44 15th Street, Orange Grove, Johannesburg. 16 August 1983, 45 Observatory Avenue, Observatory, Johannesburg, accountant. Witwatersrand Local, 8 December 1987, 10 a.m. Section 124 (2) (a) of Act 24 of 1936 as amended.

T71/84—**Garratt, Kevin John**, 9 October 1946, 4610095080000, formerly a partner of Yesterday's Restaurant, Aliwal Street, Durban. 14 February 1984. Witwatersrand Local, 12 January 1988, 10h00. In terms of section 124 (2) (a) of the Insolvency Act, No. 24 of 1936, as amended, a period of 1 (one) year having elapsed since confirmation by the Master of the First and Final Liquidation and 4 (four) years having elapsed since the date of sequestration.

Vorm/Form 7

KENNISGEWING VAN KURATORS

Aangesien 'n tydperk van ses maande verloop het sedert die bekragtiging van die finale kuratorsrekenings in die boedels hieronder genoem, word hierby kennis gegee dat die kurators van genoemde boedels ingevolge artikel 155 van die Insolvensiewet, 1936, alle boeke en stukke in hulle besit wat betrekking op daardie boedels het (behalwe die wat by die Meesters ingedien moet word), ses weke na die datum hiervan sal vernietig.

Die besonderhede word verstrek in die volgorde: Nommer van boedel; naam en beskrywing van boedel; datum van sekwestrasiebevel; afdeling van Hooggeregshof waardeur bevel gegee is; datum van bekragtiging van finale rekening, en naam en adres van kurator.

NOTICE OF TRUSTEES

Notice is hereby given that a period of six months having elapsed since the confirmation of the final trustees' accounts in the estates mentioned below, the trustees of the said estates will, pursuant to section 155 of the Insolvency Act, 1936, destroy all the books and documents in their possession relating to the said estates (except those which are required to be lodged with the Masters) after six weeks from the date of this notice.

The particulars are given in the following order: Number of estate; name and description of estate; date of sequestration order; division of the Supreme Court by which order made; date of confirmation of final account, and name and address of curator.

- T366/82—**Cassamajee, H.** 9/3/82, Witwatersrandse Plaaslike. 3/8/83. H. Kaplan, Posbus 16185, Doornfontein, 2028.
 T92/80—**Clayton, A.** 24/1/80, Witwatersrandse Plaaslike. 9/9/82. J. R. Galloway, Posbus 16185, Doornfontein, 2028.
 T692/78—**Duvenhage, J. G.** 11/4/78, Transvaalse Provinsiale. 31/7/81. B. G. S. de Wet, Posbus 16185, Doornfontein, 2028.
 T744/77—**De Kock, C. F.** 11/4/78, Transvaalse Provinsiale. 25/10/78. B. G. S. de Wet, Posbus 16185, Doornfontein, 2028.
 T699/78—**Dreyer, R. P. G.** 11/4/78, Transvaalse Provinsiale. 19/6/79. H. J. T. Eloff, Posbus 16185, Doornfontein, 2028.
 T1300/78—**Roos, C. J.** 1/8/78, Transvaalse Provinsiale. 8/8/80. B. G. S. de Wet, Posbus 16185, Doornfontein, 2028.
 T354/78—**Stieler, E. P.** 1/3/78, Witwatersrandse Plaaslike. 7/10/80. B. G. S. de Wet, Posbus 16185, Doornfontein, 2028.
 T1143/81—**Steinberg, J. J.** 15/9/81, Transvaalse Provinsiale. 21/3/83. B. G. S. de Wet, Posbus 16185, Doornfontein, 2028.
 T24/81—**Taute, J.** 13/1/81, Witwatersrandse Plaaslike. 14/6/83. B. G. S. de Wet, Posbus 16185, Doornfontein, 2028.
 T484/78—**Urfig, M.** 21/3/78, Witwatersrandse Plaaslike. 17/6/80. B. G. S. de Wet, Posbus 16185, Doornfontein, 2028.
 T570/80—**Van der Walt, P. J.** 29/4/80, Witwatersrandse Plaaslike. 1/3/83. J. R. Galloway, Posbus 16185, Doornfontein, 2028.
 T360/80—**Voster, T. B.** 29/4/80, Transvaalse Provinsiale. 4/10/84. J. Marais, Posbus 16185, Doornfontein, 2028.
 T608/81—**Van Wyk, C. H.** 19/5/81, Witwatersrandse Plaaslike. 5/5/86. D. J. Strauss, Posbus 16185, Doornfontein, 2028.
 T48/77—**Van Staden, A. G.** 13/1/77, Witwatersrandse Plaaslike. 24/10/82. B. G. S. de Wet, Posbus 16185, Doornfontein, 2028.
 T300/84—**Van Rensburg, G. J. J.** 13/3/84, Transvaalse Provinsiale. 3/1/86. J. R. Galloway, Posbus 16185, Doornfontein, 2028.
 T1613/79—**Westphal, D. S. G.** 16/11/79, Witwatersrandse Plaaslike. 17/8/83. H. J. T. Eloff, Posbus 16185, Doornfontein, 2028.
 T23/81—**Whaits, R. T. P.** 13/1/81, Witwatersrandse Plaaslike. 19/7/82. J. R. Galloway, Posbus 16185, Doornfontein, 2028.
 T1699/79—**Bentley, F. P.** 4/12/79, Transvaalse Provinsiale. 22/6/81. H. J. T. Eloff, Posbus 16185, Doornfontein, 2028.
 T1/82—**De Bruin, P. A. J.** 29/12/81, Witwatersrandse Plaaslike. 13/9/83. H. Kaplan, Posbus 16185, Doornfontein, 2028.
 T40/78—**Du Pisanke, F. J.** 10/1/78, Witwatersrandse Plaaslike. 24/9/82. B. G. S. de Wet, Posbus 16185, Doornfontein, 2028.
 T1115/80—**Gruskin, R. B.** 7/10/80, Witwatersrandse Plaaslike. 21/12/81. B. G. S. de Wet, Posbus 16185, Doornfontein, 2028.
 T470/79—**Hatting, F. G.** 27/3/79, Witwatersrandse Plaaslike. 27/10/80. J. R. Galloway, Posbus 16185, Doornfontein, 2028.
 T490/79—**Jacobs, I. J. M.** 4/4/79, Witwatersrandse Plaaslike. 27/7/81. H. J. T. Eloff, Posbus 16185, Doornfontein, 2028.
 T1999/78—**Joseph, S.** 12/12/78, Witwatersrandse Plaaslike. 24/11/80. B. G. S. de Wet, Posbus 16185, Doornfontein, 2028.
 T850/78—**Kock, K. S.** 16/5/78, Witwatersrandse Plaaslike. 14/1/81. B. G. S. de Wet, Posbus 16185, Doornfontein, 2028.
 T1350/77—**Kerbel, M.** 9/8/77, Witwatersrandse Plaaslike. 1/3/82. B. G. S. de Wet, Posbus 16185, Doornfontein, 2028.
 T990/80—**Logie, R. A.** 26/8/80, Transvaalse Provinsiale. 30/4/82. J. R. Galloway, Posbus 16185, Doornfontein, 2028.
 T504/77—**L'Estrange, J. A.** 8/3/77, Transvaalse Provinsiale. 10/7/79. J. R. Galloway, Posbus 16185, Doornfontein, 2028.
 T204/77—**Marais, A. C.** 8/2/77, Witwatersrandse Plaaslike. 24/10/77. B. G. S. de Wet, Posbus 16185, Doornfontein, 2028.
 T1685/77—**Mayne, J.** 12/10/77, Witwatersrandse Plaaslike. 27/3/79. B. G. S. de Wet, Posbus 16185, Doornfontein, 2028.
 T510/80—**Murray, H. M.** 3/5/80, Transvaalse Provinsiale. 23/9/81. H. J. T. Eloff, Posbus 16185, Doornfontein, 2028.
 T34/77—**Piliszek, T. S.** 11/1/77, Transvaalse Provinsiale. 28/11/78. J. R. Galloway, Posbus 16185, Doornfontein, 2028.
 T1138/84—**Pretorius, G. J.** 22/5/84, Witwatersrandse Plaaslike. 17/4/86. H. J. T. Eloff, Posbus 16185, Doornfontein, 2028.
 T2041/77—**Recine, G.** 14/12/77, Witwatersrandse Plaaslike. 11/6/79. J. R. Galloway, Posbus 16185, Doornfontein, 2028.
 T1573/79—**Robinson, L. M.** 6/11/79, Witwatersrandse Plaaslike. 27/4/82. B. G. S. de Wet, Posbus 16185, Doornfontein, 2028.

- T2634—**Germiston Fast Foods**, in likwidasie. 27/11/84, Witwatersrandse Plaaslike. 9/10/86. H. Zinman, Posbus 16185, Doornfontein, 2028.
 T734/83—**Ramsays Artison & Draft Hlre (Edms.) Bpk.**, in likwidasie. 20/4/83, Witwatersrandse Plaaslike. 29/1/86. H. Zinman, Posbus 16185, Doornfontein, 2028.
 T1031/82—**Roddum Engineering (Edms.) Bpk.**, in likwidasie. 13/7/82, Witwatersrandse Plaaslike. 7/11/85. H. Zinman, Posbus 16185, Doornfontein, 2028.
 T1343/85—**Gerlins Selfbediening Skoenwinkel (Edms.) Bpk.**, in likwidasie. 30/4/85, Witwatersrandse Plaaslike. 25/8/86. J. R. Galloway, Posbus 16185, Doornfontein, 2028.
 T1905/82—**Turbo Tyres (Edms.) Bpk.**, in likwidasie. 25/11/82. 15/11/85. H. Zinman, Posbus 16185, Doornfontein, 2028.
 T1878/78—**Rosner, W. A.** 22/11/78, Witwatersrandse Plaaslike. 16/1/81. J. R. Galloway, Posbus 16185, Doornfontein, 2028.
 T855/79—**Hoffmeyer, H. D. R.** 19/6/79, Transvaalse Provinsiale. 16/10/80. H. J. T. Eloff, Posbus 16185, Doornfontein, 2028.
 T711/80—**Horn, A.** 10/6/80, Transvaalse Provinsiale. 6/8/81. F. G. Gay, Posbus 16185, Doornfontein, 2028.
 T1099/78—**Moore, S. G.** 27/6/78, Witwatersrandse Provinsiale. 13/12/82. J. R. Galloway, Posbus 16185, Doornfontein, 2028.
 T955/77—**Rlichter, S.** 1/6/77, Witwatersrandse Plaaslike. 4/8/78. J. R. Galloway, Posbus 16185, Doornfontein, 2028.
 T12/80—**Spencer, D.** 2/1/80, Witwatersrandse Plaaslike. 17/9/81. J. R. Galloway, Posbus 16185, Doornfontein, 2028.
 T462/78—**Slater, N. S.** 4/7/78, Transvaalse Provinsiale. 21/1/81. B. G. S. de Wet, J. J. Mathee, Posbus 16185, Doornfontein, 2028.
 T633/78—**Smith, A. J. C.** 12/4/78, Witwatersrandse Plaaslike. 23/12/80. B. G. S. de Wet, Posbus 16185, Doornfontein, 2028.
 T11/77—**Theocharous, I.** 4/1/77, Witwatersrandse Plaaslike. 13/10/78. B. G. S. de Wet, Posbus 16185, Doornfontein, 2028.
 T1066—**Van der Merwe, J. H.** 23/9/80, Transvaalse Provinsiale. 14/10/81. J. R. Galloway, Posbus 16185, Doornfontein, 2028.
 K43/78—**Van Rensburg, C. J.** 27/10/78, Noord-Kaapse. 27/7/81. B. G. S. de Wet, Posbus 16185, Doornfontein, 2028.
 T1691/78—**Van der Westhuizen, A. J.** 17/10/78, Witwatersrandse Plaaslike. 13/9/80. B. G. S. de Wet, Posbus 16185, Doornfontein, 2028.
 T1955/85—**Vella Home Improvements (Pty) Ltd**, in liquidation. 25/6/85, Witwatersrand Local. 4/3/87. S. Trakman, c/o Highveld Trust & Management C.C., P.O. Box 10463, Johannesburg, 2000.

Vorm/Form 8

DATUMS VASGESTEL VIR DIE BEWYS VAN EISE DEUR SKULDEISERS

Ingevolge artikel 179 (2) van die Maatskappywet, 1926, artikel 366 (2) van die Maatskappywet, 1973, word hierby kennis gegee van die datums of termyne deur Meesters van die Hooggeregshof vasgestel tot wanneer skuldeisers van maatskappye in likwidasie hulle eise moet bewys of anders van die voordeel van 'n distribusie kragtens 'n rekening by die Meester ingedien voordat daardie eise bewys is, uitgesluit word.

Die besonderhede word verstrekk in die volgorde: Nommer van maatskappy in likwidasie; naam en beskrywing van maatskappy; datum of termyn deur Meester vasgestel; naam en adres van likwidateur.

DATES FIXED FOR CREDITORS TO PROVE CLAIMS

Pursuant to section 179 (2) of the Companies Act, 1926, section 366 (2) of the Companies Act, 1973, notice is hereby given of the dates or times fixed by Masters of the Supreme Court by which creditors of companies in liquidation are to prove their claims or otherwise be excluded from the benefit of any distribution under any account lodged with the Master before those debts are proved.

The particulars are given in the following order: Number of company in liquidation; name and description of company; date or time fixed by the Master; name and address of liquidator.

T182/87—**Wig Wam Canyon Investments (Pty) Ltd.** 29/11/87. J. L. C. Fourie, c/o Arthur Young Trust & Management Co. (Pty) Ltd, 15th Floor, Main Central, 112 Main Street, Johannesburg.

T564/87—**Campbell and Lockwood (Pty) Ltd**, in liquidation. 13/11/87. P. W. M. Reynolds, c/o Arthur Young Trust & Management Co. (Pty) Ltd, 15th Floor, Main Central, 112 Main Street, Johannesburg.

T4834/86—**V H Cables (Pty) Ltd**, in liquidation. 13/11/87. P. W. M. Reynolds, c/o Arthur Young Trust & Management Co. (Pty) Ltd, 15th Floor, Main Central, 112 Main Street, Johannesburg.

Vorm/Form 9

KENNISGEWINGS VAN OORGAWA VAN 'N SKULDENAAR SE BOEDEL

Ingevolge artikel 4 (1) van die Insolvensiewet, No. 24 van 1936, soos gewysig, word hierby deur 'n versoeker kennis gegee van sy aansoek wat by die Hooggeregshof op die dag en tyd soos genoem gedoen sal word, of so spoedig daarna as wat die saak verhoor kan word, om aanname van die oorgawe van sy boedel; of van die intrekking van 'n sodanige vroeëre kennisgewing van oorgawe en na verkryging van die Meester se toestemming, ingevolge artikel 7 van die Wet.

Die inligting word, waar van toepassing, verstrekk in die volgorde: (1) Naam van aansoeker, beroep en adres, styl van vennootskap of firma, en name en adresse van vennote; (2) of 'n aansoek, die Afdeling van die Hooggeregshof en datum en tyd van aansoek, of intrekking van 'n kennisgewing van oorgawe en datum van Meester se toestemming; (3) datum vanaf wanneer sy vermoëstaat ter insae sal lê vir 14 dae, die Meester se kantoor en, indien so, die Landdros se kantoor waar dit sal lê; (4) die prokureur vir die aansoeker, adres en datum.

NOTICES OF SURRENDER OF A DEBTOR'S ESTATE

In terms of section 4 (1) of the Insolvency Act, No. 24 of 1936, as amended, notice is hereby given by a petitioner of his making an application to the Supreme Court on the date and time as stated or as soon thereafter as the matter can be heard, for the acceptance of the surrender of his estate; or of the withdrawal of such notice of surrender previously made and upon having received the Master's consent, in terms of section 7 of the Act.

The information, where applicable, is given in the following order: (1) Name of petitioner, occupation and address, style of partnership or firm, and names and addresses of partners; (2) whether application, Division of Supreme Court and date and time of application, or withdrawal of notice of surrender and date of Master's consent; (3) date as from which a statement of his affairs will lie for inspection for 14 days, the Master's Office where lying and, if so, the Magistrate's Office; (4) attorney for petitioner, address and date.

Davies, Robert Henry, gebore op 18/10/46, Persoonsnommer 4610185166008, werkloos, voorheen handeldrywend as Vaal Sports te Kingsleylaan, Orkney, Transvaal en A.R. Sports te Krugerstraat, Viljoenskroon, Oranje-Vrystaat, tans van Huis 128, Evkom, Vierfontein, Oranje-Vrystaat. (2) Aansoek, Oranje-Vrystaatse Provinsiale, 12 November 1987, 10h00. (3) 19 Oktober 1987 tot 2 November 1987, Bloemfontein, Viljoenskroon, Oranje-Vrystaat en Klerksdorp, Transvaal. (4) L'Ange De Waal & Freysen, Ferum Huis, Kockstraat 22, Posbus 59, Klerksdorp, 8/10/87.

Jonck, Henrietta, *née* Grobbelaar, teacher, 11 Otto du Plessis Street, Worcester. (2) Cape of Good Hope Provincial, 10/11/87. (3) 21 October 1987, Cape Town, Worcester. (4) Sharp & Trisos, First Floor, Creative House, 31 Parliament Street, Cape Town.

Rietoff, Sidney, Identiteitsnommer 4307035072003, getroud binne gemeenskap van goedere met Maria Magrietha Rietoff, gebore Jansen van Rensburg, handeldrywende as 'n boukontraakteur onder die naam Gouriet Bouers, en woonagtig te Devonstraat 26, Gordonsbaai. (2) Kaap die Goeie Hoop Provinsiale, 6 November 1987, 10.30 vm. (3) 19 Oktober 1987, Kaapstad, Strand. (4) Thys Viljoen, p/a Holder, W. P. Boiskin & Viljoen, Posbus 40, Strand, 7140.

Van Wyk, Johan, Identiteitsnommer 4407155007001, verteenwoordiger, Jansenstraat 23, La Hoff, Klerksdorp. (2) Aansoek, Transvaalse Provinsiale, 10 November 1987, 10h00. (3) 16 Oktober 1987, Pretoria, Klerksdorp. (4) Jock du Preez, Vorster & Wessels, Western House, Boomstraat 39, Posbus 101, Klerksdorp.

KENNISGEWING VAN BOEDELOORGAWE

Hiermee word kennis gegee dat op die 16de dag van November 1987 om 10h30, of so spoedig daarna as wat die saak aangehoor kan word, by die Provinsiale Afdeling Kaap die Goeie Hoop van die Hooggeregshof aansoek gedoen sal word om aanname van die oorgawe van die gemeenskaplike boedel van **Eric James Hugo en Brenda Hugo**, voorheen handelende as Select Trousseau te Sandsteenstraat 35, Stellenberg, Bellville en as Hugo en Else Grafstene te Voortrekkerweg, Goodwood en woonagtig te Turnerstraat 29, Windsorpark, Kraaifontein en dat hul vermoëstaat te die kantoor van die Meester van die Hooggeregshof te Roelandstraat 37, Kaapstad en te die kantoor van die Landdros, Landdroskantoor, Voortrekkerweg, Goodwood ter insae sal lê gedurende 'n termyn van veertien dae vanaf die 16de dag van Oktober 1987.

Gedateer te Bellville op hierdie 29ste dag van September 1987.

G. Brits, vir Silberbauers, Prokureurs vir Applikant, Unitedgebou, Crossstraat, Bellville. (Verw. GB/ES/M7G0371).

KENNISGEWING VAN OORGAWE VAN SKULDENAAR SE BOEDEL

[Artikel 4 (1)]

Kennis word hiermee gegee dat aansoek gedoen sal word na die Transvaalse Provinsiale Afdeling van die Hooggeregshof van Suid-Afrika op Dinsdag, 10 November 1987 om 10h00 of so spoedig moontlik daarna as wat die aansoek gehoor kan word, vir die aanname van die oorgawe van die boedel van **Pieter Hendrik Schalk van der Merwe**, 'n meerderjarige elektrisiën, getroud binne gemeenskap van goedere met **Martha Maria van der Merwe**, 'n meerderjarige ontvangsdame met Identiteitsnommer 4511030037008, en wat woonagtig is te President Krugerstraat 35a, Middelburg, Transvaal. Die Applikant se Identiteitsnommer is 4910065034007. Die Applikant se Vermoënstaat sal ter insae lê vir inspeksie by die kantoor van die Meester van die Hooggeregshof, Pretoria, en te die Landdroskantoor, Middelburg, Transvaal, vir 'n tydperk van 14 (veertien) dae, gereken vanaf 19 Oktober 1987.

Gedateer te Pretoria op hierdie 6de dag van Oktober 1987.

Antonie Potgieter, Prokureur vir Applikant, Posbus 702, Middelburg, Transvaal.

VERLORE LEWENSVERSEKERINGSPOLISSE LOST LIFE INSURANCE POLICIES

Vorm/Form VL

Artikel 64, Wet 27 van 1943

Kennisgewing geskied hiermee dat bewys van die verlies of vernietiging van die polisse hieronder vermeld, aan die versekeraars gelewer is, en enigeen wat in besit van enige van hierdie polisse is, of aanspraak maak dat hy enige belang daarin het, moet onmiddellik per aangetekende pos met die versekeraars in verbinding tree. By gebreke aan sodanige mededeling sal gewaarmerkte afskrifte van polisse (wat die enigste bewys van die kontrak sal wees) aan die eienaars uitgereik word ingevolge die regulasies gepromulgeer onder die Wet.

Die besonderhede word verstrek in die volgorde: Naam en adres van versekeraar; polisnommer, datum van polis en versekerde bedrag; lewe verseker; eienaar, indien ander as versekerde.

Section 64, Act 27 of 1943

Notice is hereby given that evidence of the loss or destruction of the policies mentioned below, has been submitted to the insurers, and any person in possession of any of these policies, or claiming to have any interest therein, should communicate immediately by registered post with the insurers. Failing any such communication, certified copies of the policies (which shall be the sole evidence of the contract) will be issued to the owners in terms of the regulations framed under the Act.

The particulars are given in the following order: Name and address of insurer; policy number, date of policy, and sum insured; life insured; owner, if other than insured.

AA Mutual Lewens, Posbus 1653, Johannesburg, 2000

L022497—1/8/67, R1 000. Richard Kobani Cagwe; Simon Bikitcha Cagwe.

L0526737—1/10/83, R74 372. Annelie Slabber.

L0224494—1/8/84, R20 000. Petrus Johannes Nieuwenhuizen.

Allianz Lewens Bpk., Posbus 7283, Pretoria, 0001

80200587—1/12/86, R65 544. Francis John Atrash; D. W. Saad.

21003957—28/9/72, R20 000. Grant James Marshall.

21007510—29/10/73, R4 500. Nicolaas Frans Kotze.

21006183—1/2/73, R10 989. Johan de Vos; Barclays Bank—Beaufort-Wes.

21015572—30/3/82, R16 000. Kevin Neil Britz.

80012616—30/5/84, R10 550. Johannes Diedrich Geldenhuys.

80140096—18/7/85, R13 809. Abraham Malgas.

Avbob, Posbus 1661, Pretoria, 0001

AL0019992x7—1/4/84, R3 000. A. Bester.
 AL0011632x7—1/9/83, R2 000. M. E. Kuhn.
 AL0011633x5—1/9/83, R2 000. M. E. Kuhn.

Commercial Union Assurance Co of S.A. Ltd., P.O. Box 222, Johannesburg, 2000

805585—2/7/86, R7 200. Petrus Breach Ngwenya.
 268309—10/7/64, R3 500. E. G. Armstrong.
 532980—15/1/82, R50 000. John James Perkins.
 510431—21/1/75, R6 788. A. J. B. Maclou.

Crusader Life Assurance, 10 Anderson Street, Johannesburg, 2000

041/056/1845—1/11/86, R1 204. H. N. Dixon.
 161044260208—1/2/82, R1 000. J. J. Khumalo.
 041056000978—16/6/83, R4 790. W. C. le Roux.

Momentum Lewensversekeraars Bpk., Posbus 7283, Pretoria, 0001

7510015x6—16/11/79, R50 000. Jan Hendrik Rossouw.
 8459634x0—1/3/87, R140 000. Luis P. D. Basilio.
 7530495x3—29/9/83, R4 380. Cornelia Schoeman.
 8402384x5—4/6/84, R35 038. Cornelius Francois Meyer.
 7527897x7—19/5/83, R125 000. Petrus Stephanus Janse van Rensburg.
 7506242x1—29/1/79, R4 000. Booysen Jonathan Jan Prinsloo.
 7514254x5—15/12/80, R20 000. Coenraad Fredrika Gouws.
 7511507x0—16/4/80, R75 000. Jan Bernardus Willers; Gertruida Jacoba Willers.
 7531333x7—5/10/1983, R13 203. Marthinus Johannes Damoen Paulsen.
 8459007x6—1/4/87, R61 000. Jacoba E. M. de Jager.
 7518168x6—1/9/81, R15 102. Paul Mathys.
 771836—12/3/62, R1 200. Anthony Stirling Broughton.

Old Mutual, Posbus 66, Kaapstad, 8000

4546793—7/9/84, R8 068. X. Simani.
 4269268—16/9/83, R29 038. C. Stander.
 4004594—18/9/82, R5 782. A. de Meyer.
 3771296—15/6/81, R50 000. M. D. Bailes (née De Beyer).
 5281839—11/4/87, R25 667. A. H. Louw.
 4855834—16/11/85, R50 000. V. C. Visser.
 4818636—5/12/85, R7 977. C. J. Loubser; F. Le R. Loubser.
 4535582—23/8/84, R2 045. J. A. Venter.
 4488210—21/6/84, R12 074. C. van Rooyen.
 2241754—1/10/69, R2 693. J. P. H. Maree.
 4712991—11/5/85, R10 754. R. Matlala.
 4278168—2/9/83, R10 429. Z. P. Sakwe.
 4282588—24/3/84, R10 355. P. Naidoo.
 4236049—16/7/83, R13 878. K. Naidoo.
 3984950—21/6/82, R10 006. D. Bodenstien.
 3884655—23/11/81, R21 108. J. C. W. Wilkinson.
 3295597—18/9/78, R3 674. W. J. Thomas.
 5181104—2/1/87, R11 268. N. Mwaala en andere/and others; I. Mwaala.
 5005467—6/6/86, R21 636. T. C. Nyawose.
 4640627—4/2/85, R19 964. B. N. Vanda. (AD866/867-20)
 3789099—27/7/81, R16 552. N. Reddy.
 3812916—20/7/81, R21 601. N. Reddy.
 5031209—5/7/86, R11 351. Y. Domingo.
 4299907—3/10/83, R406. D. Rahman.
 2595418—9/7/73, R2 688. M. de S. Ferreira.
 3737510—20/5/81, R1 434. M. de S. Ferreira.
 3234208—17/4/78, R11 568. W. J. Muller.
 3615243—19/6/81, R2 575. Z. Doron.
 2550859—20/2/73, R518. D. Casling; W. Casling.
 5160506—16/2/87, R18 558. T. Njoza en andere/and others; N. B. Njoza.
 5082291—19/2/87, R20 656. J. M. Mashologu.
 5135429—2/3/87, R39 739. G. I. Potgieter.
 3888804—30/11/81, R24 900. R. J. Fullerton; Rondebosch Travel (Pty) Ltd/Edms., Bpk.
 4305210—14/10/83, R12 600. R. J. Fullerton; Rondebosch Travel (Pty) Ltd/Edms., Bpk.
 4022019—12/3/83, R10 296. J. L. Feuilherade.
 2156609—27/6/68, R198. P. M. Saul; E. N. Saul.
 2156627—27/6/68, R198. X. Saul; E. N. Saul.
 5380495—18/7/87, R20 012. S. A. May.
 3112445—23/5/77, R3 003. W. J. Alberts.
 3662532—7/11/80, R857. M. de S. Ferreira. (AD868/869-20)
 2512118—15/9/72, R167. J. J. de Goede; Boedel wyle/Estate late H. N. de Goede.
 2512117—15/9/72, R114. J. J. de Goede; Boedel wyle/Estate late H. N. de Goede.
 2406190—16/9/71, R2 000. C. G. Hansson.
 2189882—7/1/69, R5 000. R. M. van Niekerk; B. J. P. Malan.
 1964477—17/6/5, R1 139. P. V. Cauvarel.
 5328325—28/5/87, R6 576. T. Nangolo.
 2917699—17/11/75, R2 022. W. A. Boesak.
 3221541—17/3/78, R3 561. E. R. Landsdell.

- 4154332—28/2/83, R51 922. M. C. Wade.
 5204556—6/2/87, R27 114. L. T. Skolo.
 5338771—11/6/87, R30 000. S. V. Ganda; J. Ganda.
 2644537—3/10/73, R4 406. E. A. N. Steenkamp.
 3353544—19/2/79, R1 336. A. Strauss; J. C. Strauss.
 5111417—23/10/86, R8 863. A. de Wet.
 4598771—23/11/84, R6 723. B. A. Williams.
 3853211—21/9/81, R3 693. M. S. Dibeco.
 4494128—28/6/84, R12 645. E. T. Mavundla.
 3497914—19/12/79, R3 314. B. Z. Mzimela.
 5322536—18/6/87, R29 787,87. J. H. Lambrechts.
 4836600—29/10/85, R50 000. J. E. Cassel; M. C. W. Louch; A. Pillay. (AD871/AD872)
 4376514—12/3/84, R4 810. A. W. Stander.
 4113910—10/12/82, R6 248. N. W. Maloma; Boedel wyle/Estate late S. E. Maloma.
 2178169—21/10/68, R921. D. van Wyk.
 2148683—17/5/68, R3 000. P. C. Havenga; Santambank.
 2274167—23/3/70, R4 000. A. G. McDonald.
 5069881—11/10/86, R37 913. H. Shifugula.
 5334458—6/6/87, R7 659. M. C. Ndovela.
 5206282—7/2/87, R14 618. A. K. Phala.
 4826634—10/10/85, R121 302. G. R. Tomlinson.
 4683197—28/3/85, R60 180. P. N. Vermeulen; V. Coetzee.
 4767576—22/7/85, R5 621. Wyle/Late R. E. Bloem; M. F. Bloem.
 4386001—11/2/84, R20 008. L. L. Wesli.
 4046423—9/8/82, R918. C. P. van der Merwe.
 4046424—9/8/82, R918. C. P. van der Merwe.
 3601330—22/8/80, R8 000. G. J. Kok.
 2970923—10/5/76, R1 779. S. van Niekerk; A. C du P. van Niekerk.
 3048926—25/11/76, R2 266. F. P. van Niekerk; A. C. du P. van Niekerk.
 2698604—14/3/74, R2 440. A. J. de Beer.
 2659152—13/11/73, R4 000. H. E. van der Merwe; Maradele Edms., Beleggings Beperk.
 4476075—7/6/84, R9 931. E. C. D. Putter. (AD873/AD874).
 4087328—22/10/82, R30 000. F. J. Terblanche.
 4000916—23/7/82, R7 005. S. G. Pantsi.
 3932203—11/3/82, R25 209. W. Qeqe.
 3856749—28/9/81, R7 842. J. J. Myburgh.
 3852180—19/9/81, R3 061. N. Qeqe.
 3779248—8/7/81, R6 131. S. G. Opperman.
 3426383—27/8/79, R13 405. W. N. Mafukuzela.
 3104412—2/5/77, R4 610. R. Kara.
 4586089—2/11/84, R8 638. S. P. Moloi.
 4476652—7/6/84, R3 639. P. Lietsiso; Q. M. Lietsiso.
 2245365—31/10/69, R4 409. R. J. Grobler.
 4633588—21/1/85, R96 888. E. J. R. Marillier.
 3719472—14/3/81, R10 001. N. Barkley; R. M. Barkley.
 3305671—9/10/78, R811. C. L. Davies; B. C. Davies.
 3091521—28/3/77, R19 520. G. F. S. Gorgulho.
 3089048—21/3/77, R12 449. R. M. Medhurst; Trust Bank.
 2874809—28/7/75, R3 000. D. Ferguson.
 5192893—23/1/87, R18 641. W. J. Smith.
 5137780—21/11/86, R24 933. W. P. Manjezi.
 4903391—6/2/86, R34 620. A. L. Du Val. (AD875/AD876).
 3498477—1/12/79, R3 002. Wyle/Late F. S. Smit; Boedel wyle/Estate late F. S. Smit.
 3475886—1/11/79, R4 025. Wyle/Late F. S. Smit; Boedel wyle/Estate late F. S. Smit.
 4010468—24/2/83, R11 714. P. M. Pilz, Pilz Precision Tools.
 3861501—8/10/81, R312. R. J. Mtombeni; M. D. Mthombeni.
 2867519—4/7/75, R4 059. L. W. Venter.
 3569326—5/6/80, R5 406. L. W. Venter.
 2415383—3/11/71, R2 000. C. H. Bothma.
 3597398—14/8/80, R4 167. A. E. Joubert.
 5157838—5/12/86, R17 234. S. S. Khumalo; H. N. Khumalo.
 5157703—31/1/87, R28 181. H. N. Khumalo.
 2916700—17/11/75, R2 959. J. G. Theron.
 4337206—25/11/83, R526. D. J. Nader.
 3654161—20/10/80, R9 993. M. Sarrepin.
 4686046—30/3/85, R27 790. N. C. Mountfield.
 4501616—6/7/84, R15 000. L. A. Willeston.
 4223289—23/6/83, R8 369. J. P. Bezuidenhout.
 3869139—23/10/81, R6 263,51. L. E. Nyonkong.
 4232504—5/7/83, R15 621. S. S. Nyonkong; E. L. Nyonkong.
 3809214—9/9/81, R8 021. L. E. Nyonkong.
 4220647—24/8/83, R14 794. E. D. Nyonkong; E. L. Nyonkong. (AD877/AD878).
 3816941—6/11/81, R20 000. Wyle/Late J. Murphy; Boedel wyle/Estate late J. Murphy.
 1246140—4/10/56, R1 000. Wyle/Late T. P. Whittle; G. Whittle.
 2085860—6/6/67, R188. D. R. Seargent.
 2109844—12/10/67, R1 000. C. P. Louw.
 3162368—3/10/77, R1 377. H. L. H. C. de Jager.
 2171249—12/9/68, R229. J. H. M. Jooste.

- 3845524—25/6/81, R2 596. A. K. Khonyane.
 1532564—7/10/59, R578. D. D. M. Fisher.
 2104879—2/10/67, R1 000. G. E. Verster.
 1239149—11/9/56, R2 000. J. D. van Eeden; E. F. de V. van Eeden.
 4437859—25/6/84, R13 855. M. C. Pienaar (Née Nieuwenhuis).
 5033017—7/7/86, R19 662. R. D. A. Tlhoale.
 4087728—23/10/82, R10 151. D. R. Tlhoale.
 4065188—13/9/82, R24 340. I. van der Merwe.
 4634372—28/1/85, R4 080. J. A. Myburgh.
 2318164—17/9/70, R1 864. D. S. F. Josef.
 1918202—19/10/64, R2 000. C. G. C. Brown; J. N. Brown.
 2105772—2/10/67, R1 000. P. J. Labuschagne.
 1610577—30/9/60, R2 216. C. Horn.
 2104353—12/9/67, R1 000. F. J. Kruger. (AD879/AD880).
 3309732—21/10/78, R2 500. E. K. Matodzi.
 5145933—15/11/86, R14 062. Z. A. Els.
 3155434—12/9/77, R3 253. J. H. S. Fourie.
 5314298—16/5/87, R149 316. W. J. van Niekerk.
 4078189—7/10/82, R8 944. F. Homses.
 5146837—16/11/86, R16 009. N. Nkolele and D. Nkolele; M. Nkolele.
 2885060—28/8/75, R15 254. P. G. Kritzinger.
 3141425—7/6/77, R2 497. H. N. Mayeko; E. K. Mayeko.
 2886450—9/6/75, R3 421. R. A. Cato.
 2984340—24/5/76, R7 000. B. J. Engelbrecht.
 1840674—21/8/63, R3 000. C. J. Louw.
 5355018—25/6/87, R11 316. S. Throsson.
 4487370—18/6/84, R6 290. N. Z. Madikane.
 4443020—19/4/84, R7 131. M. S. Shah.
 4568562—27/12/84, R10 288. L. G. Thompson.
 4489097—22/6/84, R16 421. G. Ayerst.
 489911—4/5/44, R1 000. E. A. Cilliers.
 2087163—12/6/67, R5 121. L. B. Lemmer; Boedel wyle/Estate late A. M. Lemmer.
 2416346—20/10/71, R9 000. D. W. van Wyk.
 4475702—2/6/84, R4 398. S. R. Mamabolo. (AD881/AD882).
 4880674—26/12/85, R28 084. R. G. A. Hoekstra.
 5005927—16/6/86, R29 016. S. T. Ngcofe; B. S. Ngcofe.
 4725336—25/5/85, R5 685. H. P. Mathebula.
 4576922—29/10/84, R14 080. M. M. P. Thompson.
 3994232—5/7/82, R8 082. J. Hall.
 3420876—29/7/79, R1 227. D. R. Mathare; I. M. S. Seipei.
 5096593—23/10/86, R4 123,88. V. L. Baloyi.
 4543780—3/9/84, R13 664. M. A. Mbatha.
 4471635—15/6/84, R11 397. H. J. Combrinck.
 3968243—25/5/82, R32 036. W. Qeque.
 5138061—28/2/87, R8 620. M. Robinson.
 3119470—13/6/77, R15 000. P. W. H. Gaus.
 3917902—12/2/82, R3 810. U. M. Mnotoza; N. S. Mnotoza.
 2869857—21/7/75, R4 000. M. M. Zele.
 4046040—9/8/82, R7 403. L. Potgieter.
 5266923—19/4/87, R17 310. R. W. Bryla.
 4862540—20/2/86, R6 132. B. M. Nzuza; Jan Smith Motors.
 4432620—29/6/84, R7 580. P. J. Haccou.
 4122293—27/12/82, R8 416. M. B. Jikela.
 4966855—20/4/86, R32 091. W. G. Brits. (AD883/884).
 3936727—18/3/82, R4 167. J. F. Boshoff.
 3599983—18/8/80, R25 858. F. P. Aldrich.
 2857228—10/6/75, R5 000. C. H. Schreuder.
 2793422—26/11/74, R2 000. W. Adriaanse; M. A. Kotze.
 4876806—13/12/85, R6 523. H. S. Masia.
 4297307—30/9/83, R12 922. M. P. Smit.
 3686995—2/1/81, R2 257. M. C. Ngoveni; T. P. Ngoveni.
 4972344—19/5/86, R8 272. S. van Wyk; L. M. Dobell.
 4543856—10/9/84, R9 850. A. Naris.
 4341664—12/12/83, R10 000. M. J. H. vd Berg.
 2262884—23/1/70, R6 000. Wyle/Late J. A. Serfontein; Boedel wyle/Estate late J. A. Serfontein.
 2480420—3/7/72, R1 648. Wyle/Late J. A. Serfontein; Boedel wyle/Estate late J. A. Serfontein.
 1854032—31/10/63, R2 890. Wyle/Late W. M. Walsh; Boedel wyle/Estate late W. M. Walsh.
 517922—17/5/45, R5 000. Wyle/Late E. T. S. Brown; K. F. Brown.
 432801—26/6/41, R2 000. Wyle/Late E. T. S. Brown; K. F. Brown.
 1831770—5/7/63, R2 000. D. H. J. Coetzee en/and Santambank.
 1694633—12/9/61, R2 916. E. Madikizela.
 5112738—5/12/86, R13 966. M. S. Mkhize.
 4999584—30/5/86, R62 011. L. P. Wasson.
 4795570—31/8/85, R21 926. J. W. Wolmarans. (AD885/AD886).
 5118107—23/10/86, R2 344. M. A. Molthahn.
 5073756—28/8/86, R23 167. B. L. Taylor.
 5115351—6/11/86, R21 758. I. Potgieter.

3875916—5/11/81, R7 702. D. P. Burger.
 4002451—23/7/82, R6 640. J. F. de Villiers.
 5028076—3/7/86, R5 1740. T. R. V. Matjila.
 1324814—31/7/57, R2 540. H. W. Vogel.
 638757—24/6/48, R1 000. M. M. E. Foord.
 3552618—26/4/80, R7 094. D. A. Lund.
 2959317—18/3/76, R3 460. D. A. Lund.
 1217240—21/6/56, R2 772. M. Poggenpoel; J. P. J. Coetzee.
 578985—13/3/47, R258. P. R. Fourie.
 622399—4/3/48, R314. P. R. Fourie.
 672151—10/3/49, R306. P. R. Fourie.
 729845—23/3/50, R296. P. R. Fourie.
 781282—15/2/51, R288. P. R. Fourie.
 2189984—10/1/69, R5 000. B. J. P. Malan; R. M. van Niekerk.
 3076677—3/3/77, R4 499. R. J. Kotze.
 3946815—5/4/82, R10 000. J. Schmidt.
 4389414—16/2/84, R17 140. J. Schmidt. (AD 888/889.)
 2673676—25/2/74, R7 578. R. W. Schmidt.
 5195804—25/1/87, R10 479. A. K. de Kock.
 3568872—2/6/80, R2 560. P. S. Mancini.
 3455096—1/9/79, R2 500. N. K. Mancini; P. S. Mancini.
 3246568—25/5/78, R5 340. P. S. Mancini.
 4232085—2/7/83, R5 495. M. J. Shaw.
 2447495—23/2/72, R3 000. H. B. Bunting; J. M. Bunting.
 2293776—16/6/70, R1 785. C. A. van der Westhuizen.
 2467168—16/5/72, R1 000. N. D. J. de Jager.
 2573635—9/5/73, R2 175. N. D. J. de Jager.
 1557369—2/2/60, R708. Wyle/Late P. W. van der Westhuizen; H. G. van der Westhuizen.
 258957—1/12/32, R1 500. Wyle/Late C. B. Spencer; Boedel wyle/Estate late C. B. Spencer.
 1914325—28/9/64, R2 438. B. C. Crous.
 912057—3/2/53, R436. B. J. G. Viljoen.
 1779147—28/9/62, R880. N. Kades; D. Kades.
 4676889—21/3/85, R10 747. S. M. Bovungana.
 4711699—9/5/85, R12 922. H. Moloj.
 3056591—13/12/76, R2 000. M. A. Khumalo.
 4982013—9/5/86, R5 433. D. J. Nel.
 4068237—18/9/82, R1 319. M. J. S. Pieterse. (AD 894/895.)

The Prudential Assurance Company of SA Ltd, P.O. Box 1097, Johannesburg

13720188—1/2/84, R13 379. B. Wentzel.
 8102917—1/7/67, R6 000. P. G. Bannock.
 10172645—1/1/82, R16 779. F. A. Roode.
 5957735—1/8/59, R4 000. S. Aber.
 5680293—1/11/52, R5 000. S. Aber.
 5680294—1/11/52, R5 000. S. Aber.
 13787453—1/2/87, R24 000. M. A. Roberts.
 10120737—1/3/76, R5 000. E. A. Smith.

Rand Lewensversekering Maatskappy Bpk., Posbus 7283, Pretoria, 0001

40374345—7/4/83, R15 000. Karel Petrus Meyer.
 40246428—4/8/80, R10 000. Gideon Diedericks.
 60157278—3/2/83, R7 323. Martin Fito Sihlangu.
 40216286—29/10/73, R4 500. Johannes Machiel Hattingh.
 60142505—1/8/82, R1 117. Foni Diko.
 35508—1/9/70, R272. Hendrik Johannes Witbooi.
 60041644—21/3/73, R4 000. Adolf James Marais.

Rentmeester Versekerers Bpk., Privaatsak X219, Pretoria

96000000752—23/2/59, R1 000. Phillipus Jacobus Scheepers.
 687695—23/2/59, R3 000. Henry Brown Dunn.
 6987—3/2/64, R2 000. Johannes Sutherland.
 80947—29/2/84, R4 250. Frederik Steyn.

Sanlam, Posbus 1, Sanlamhof, 7532

817319—1/10/59, R1 000. S. F. Millard.
 1474088x0—1/12/70, R4 528. J. D. Linde.
 3304354x8—1/4/77, R3 000. I. J. H. Kruger.
 3364267x9—1/5/77, R3 000. J. J. Corrie.
 3496330x6—1/5/79, R9 540. J. J. van der Westhuizen.
 3634972x8—1/9/79, R4 825. M. C. Vorster.
 7043387x5—1/4/82, R5 120. C. H. Claassen.
 7218096x1—1/12/82, R11 455. P. Ndlova.
 7299004x7—1/3/83, R10 191. M. G. Bunning.
 7395586x6—1/12/83, R16 079. F. M. L. Rossouw.
 7426213x0—1/12/83, R3 714. P. Geustyn.
 7460593x2—1/5/84, R24 127. J. C. Holmes.
 7463166x4—1/6/83, R7 000. A. Saayman.
 3450333x4—1/5/78, R3 270. D. A. Erasmus.
 7574653x7—1/6/84, R10 214. W. A. J. Nel.
 7622376x7—1/8/84, R3 801. M. J. Maleka.

- 7769051x9—1/9/84, R10 233. C. A. Alberts.
 7917295x3—1/7/85, R14 040. L. W. Meyer.
 9172855x0—1/5/86, R15 368. G. Botha.
 9426577x4—1/1/86, R6 485. E. E. Montenari; J. L. Serfontein.
 897576x5—1/7/61, R2 000. M. J. en D. L. Pretorius.
 975344x3—1/8/62, R4 000. R. J. du Plooy.
 1560759x1—1/8/71, R19 900. R. G. Blake.
 1794282x2—1/9/73, R1 000. F. M. Bruwer; J. A. Bruwer.
 3328758x2—1/12/76, R4 000. D. F. B. Nelson.
 3577409x0—1/7/79, R3 000. J. G. Barnard.
 7412229x2—1/11/83, R4 000. M. Viljoen; J. P. J. S. Viljoen.
 7491170x2—1/5/84, R7 060. V. L. Kilian.
 7497742x2—1/1/84, R12 834. S. Halpern.
 7572696x8—1/2/84, R5 086. W. Gouws; W. J. Gouws.
 7718617x9—1/8/84, R17 160. G. P. Airey.
 7739841x0—1/11/85, R5 040. W. G. van Heerden.
 7899683x2—1/5/85, R22 699. H. D. Bokelmann.
 9287677x0—1/7/86, R2 816. L. C. Mitchell.
 9476542x7—1/2/87, R18 952. D. J. Jordaan.
 9531155x1—1/3/87, R3 410. S. S. Ntombela.
 9574096x5—1/5/87, R34 973. J. C. Juelie.
 9575830x6—1/5/87, R50 000. J. H. van der Merwe.
 9591639x1—1/6/87, R16 251. H. Rhagabar.
 9620394x8—1/4/87, R10 000. P. P. Venter.
 7679041x9—1/7/84, R5 945. W. G. Aba.
 618745—1/9/55, R8 000. R. M. Maritz.
 1812950x2—1/4/74, R2 000. M. A. Moravec.
 3372770x2—1/6/77, R3 000. R. P. Stratford.
 3854535x6—1/9/81, R9 589. C. B. Baartman.
 3897145x3—1/3/81, R5 640. V. M. C. Rosa; Moza Construction.
 7243086x1—1/8/82, R12 030. V. M. C. Rosa.
 3944166x2—1/8/81, R6 462. A. C. Cazenga.
 7001055x8—1/11/81, R2 554. M. M. Pietersen.
 7046616x4—1/11/81, R19 400. J. H. Pretorius.
 7238733x5—1/1/83, R4 153. N. J. Dekker; A. Dekker.
 9123538x2—1/1/86, R9 805. A. Dekker.
 7280695x3—1/9/82, R6 037. R. Berry.
 7598026x8—1/6/84, R5 020. E. M. Marais.
 7659843x2—1/6/84, R13 480. A. B. Viljoen; W. J. J. Viljoen.
 9200069x4—1/5/86, R20 686. B. J. L. Aucamp.
 9437675x3—1/10/86, R30 000. F. E. de Villiers; J. E. Terblanche.
 9490632x8—1/2/87, R6 276. M. P. Mautla.
 9582911x5—1/4/87, R20 000. E. L. Botha.
 9589211x3—1/5/87, R26 358. E. Jordt.
 9612317x9—1/6/87, R11 396. H. Potgieter.
 1303088x7—1/7/68, R2 118. P. L. Viviers; J. P. Viviers.
 1742385x6—1/6/74, R1 000. M. Boshoff.
 3905639x5—1/5/81, R5 278. E. J. van Reenen.
 7264229x1—1/8/82, R13 952. P. Oosthuysen.
 7404608x7—1/5/83, R17 000. G. Thomas.
 7431316x4—1/7/83, R20 022. D. J. H. Coetzer.
 7436953x9—1/10/83, R4 329. J. M. Grobler.
 7538768x8—1/6/84, R4 000. H. Jonkerman.
 7619898x5—1/8/84, R22 933. F. P. van Vuuren.
 7622441x9—1/8/84, R4 630. F. G. du Preez.
 7787798x3—1/1/85, R11 198. M. L. Hoffman.
 7792833x1—1/1/85, R7 758. C. Andries.
 7945869x1—1/9/85, R5 601. C. du Plooy.
 7979924x3—1/10/85, R5 341. Z. Ingram.
 7979923x5—1/9/85, R12 282. B. R. Ingram.
 9188235x7—1/7/86, R100 423. H. J. de Bruyn.
 9293141x9—1/9/86, R13 849. C. W. en G. Julius.
 9530526x4—1/4/87, R42 782. G. M. Makqobinyane.
 9606502x4—1/5/87, R66 059. D. L. Ehlers.
 9708223x4—1/7/87, R29 833. V. Galassi.
 3494089x0—1/9/78, R20 000. J. D. Strydom.
 7304551x0—1/11/82, R5 458. G. E. Snyman; L. E. Mereis.
 7381194x5—1/2/84, R17 697. A. L. Steenkamp.
 7409424x4—1/4/83, R8 428. I. T. Buntain.
 7702417x2—1/12/84, R16 627. A. E. Viljoen.
 7719990x9—1/2/85, R5 871. V. S. Ndlovu.
 7894384x2—1/5/85, R26 585. P. D. B. Kotze.
 7977397x4—1/10/85, R10 940. O. J. Mokhine.
 9248078x9—1/8/86, R8 921. E. Venter.
 9148164x8—1/5/86, R14 180. A. P. J. Steyn.
 9195868x6—1/3/86, R25 307. L. Yaxaglou.
 9242348x2—1/8/86, R9 684. K. P. Johnson.
 9402329x8—1/10/86, R18 803. R. P. Diederichs.
 9487169x6—1/1/87. R16 351. G. P. Wilken.

9498948x0—1/2/87, R5 797. M. S. Moreroa; M. J. Moreroa.
 9552121x7—1/3/87, R60 000. C. Denner.
 9573176x6—1/4/87, R80 000. J. L. de Beer.
 9580730x1—1/4/87, R22 154. K. D. Butler.
 9644750x3—1/6/87, R50 000. A. Wolmarans.
 9680220x2—1/8/87, R3 628. P. S. Slungange.
 715308—1/9/57, R1 000. R. J. Booysen.
 1453568x6—1/8/70, R10 000. L. Toerien.
 1733239x6—1/3/74, R1 000. C. M. Morolong.
 1975066x0—1/8/75, R2 000. L. H. B. Moolman; A. Moolman.
 3319374x9—1/7/77, R2 252. A. N. Oelofse.
 3614945x8—1/5/80, R4 000. G. D. Pieterse; E. Pieterse.
 3625706x1—1/12/79, R5 140. H. G. Dorfling.
 3648241x2—1/4/80, R26 500. G. J. Inder.
 3725148x5—1/7/80, R10 677. B. A. Carr.
 3749215x4—1/8/80, R8 825. R. S. Everitt.
 3906436x5—1/9/82, R7 392. C. P. van der Merwe.
 7151544x9—1/4/82, R16 000. J. O. Cornelius.
 7256108x7—1/9/82, R4 500. E. Cloete.
 7496625x0—1/6/83, R8 485. G. Pillay; K. Pillay.
 7559532x2—1/2/84, R7 780. S. M. Shabane.
 7566087x8—1/2/84, R16 442. I. Kruger.
 7623600x9—1/10/84, R5 090. M. S. Ramasimu.
 7889386x4—1/6/85, R3 501. K. Chuene.
 7890557x7—1/8/85, R11 677. P. A. Hartslief.
 9370058x1—1/9/86, R9 870. R. L. Sloman.
 1741571x2—1/12/73, R3 210. A. van der Westhuizen.
 1998458x2—1/8/75, R5 000. S. Coetzee.
 3381385x8—1/6/77, R5 000. A. van Blommestein.
 3385502x4—1/4/77, R1 280. O. J. Botha.
 3515588x6—1/3/79, R3 530. H. L. van Rooyen.
 3637691x1—1/3/80, R10 000. C. G. van Vuuren.
 7031333x3—1/3/82, R3 504. R. L. Prinsloo.
 7065306x8—1/12/81, R3 559. F. M. Gqada.
 7331057x5—1/11/82, R10 950. T. J. Beytell.
 7519832x5—1/10/83, R10 000. J. Moropa.
 7524365x9—1/11/83, R21 897. P. J. Letoaba.
 7547663x0—1/1/84, R13 417. J. F. Bubb.
 7737510x3—1/12/84, R20 042. J. F. Bubb.
 7724929x0—1/9/84, R34 367. F. W. van der Wal.
 7812139x9—1/11/84, R100 987. P. H. Parbhoo.
 7831322x8—1/2/85, R7 081. G. Claassen; G. P. Claassen.
 9230843x6—1/5/86, R42 202. T. F. Voges.
 9437809x8—1/1/87, R30 000. F. A. Smit.
 9586817x0—1/5/87, R9 328. M. Moodley.
 9700432x9—1/8/87, R35 688. M. L. Potgieter.
 892906x9—1/5/61, R1 224. J. J. Lloyd.
 1293920x3—1/4/68, R2 000. A. Zeiler.
 1822376x8—1/3/74, R4 000. F. E. Perold.
 1929077x4—1/12/74, R4 000. M. Waldburger.
 1997272x8—1/6/75, R3 247. C. A. Havemann.
 3500907x5—1/12/78, R3 000. M. M. Kaira.
 7209485x7—1/8/82, R5 140. H. G. van Niekerk.
 7436748x3—1/11/83, R100 000. J. Joubert.
 7519835x8—1/10/83, R10 000. A. Matome.
 7577716x9—1/1/84, R12 575. S. M. Joubert.
 7596278x7—1/9/84, R9 029. J. E. Nortje.
 7788735x4—1/12/84, R11 049. D. B. Swart.
 9255229x8—1/6/87, R116 000. L. J. Erasmus.
 9315496x1—1/10/86, R8 017. A. F. Carelse.
 9411355x2—1/10/86, R8 399. N. P. Nxumalo.
 9497397x1—1/1/87, R100 000. J. A. van Lill.
 9693572x1—1/8/87, R76 536. M. E. Gelderblom.
 3367094x4—1/9/77, R1 280. P. A. Nell.
 7722550x6—1/9/84, R7 408. J. G. Gelser.
 7700692x2—1/3/85, R11 360. A. A. Pretorius.
 1299365x5—1/3/68, R2 000. E. Nel.
 1630021x2—1/6/72, R9 000. M. Joao.
 1897703x3—1/9/74, R3 000. D. F. en M. J. du Plooy.
 7123241x7—1/3/82, R4 230. J. M. Horne.
 7286342x6—1/11/82, R8 093. B. J. Mahne.
 7424192x8—1/8/83, R13 190. F. R. G. Cunningham.
 7612084x9—1/2/84, R8 025. D. J. van Tonder.
 7619648x4—1/7/84, R4 374. V. R. K. Mpolokeng.
 7820311x4—1/2/85, R13 442. C. Du P. Fensham.
 7879619x0—1/7/85, R13 445. S. Heritage.
 7915134x6—1/8/85, R7 410. M. E. Roelofse.

7940134x5—1/7/85, R16 282. J. F. Engelbrecht.
 7965916x5—1/9/85, R13 020. B. J. Mckgadi.
 7999924x9—1/10/85, R9 330. T. E. Cornelius.
 9044277x3—1/3/86, R7 785. E. S. V. W. Verwey.
 9205270x3—1/7/86, R100 000. R. W. Louw.
 9373026x5—1/11/86, R11 385. T. T. Mabhala.
 9447456x6—1/1/87, R8 080. M. P. Mokoena.
 9467098x1—1/1/87, R16 228. G. B. Mitchley.
 9510504x5—1/5/87, R33 237. O. P. Blignault.
 1433725x7—1/5/70, R5 000. C. R. Kellerman.
 1461255x0—1/5/71, R1 000. M. J. Combrink.
 1626679x3—1/9/72, R2 000. H. M. J. Combrink.
 1596020x6—1/3/72, R3 000. D. Claassen.
 1854622x6—1/4/74, R2 000. I. M. Taljaard.
 3731522x3—1/7/80, R10 543. A. C. Deas; Suidwes Safari Motels (Edms.) Bpk.
 3962213x9—1/10/81, R2 500. M. Viljoen; R. Leonard.
 3994519x1—1/11/81, R2 500. W. Richter; R. Leonard.
 7125406x4—1/9/82, R8 694. M. E. Pelser; F. P. Pelser.
 7231295x2—1/5/84, R14 961. J. J. Steyn.
 7345628x7—1/2/83, R10 000. E. C. Viljoen.
 7488875x1—1/1/84, R25 850. F. W. Maritz.
 1675637x1—1/12/72, R1 007. A. C. Maritz; F. W. Maritz.
 7712550x8—1/9/84, R9 534. P. J. Maartens.
 9072405x5—1/7/86, R42 039. D. Boehm.
 9141968x9—1/2/86, R130 013. C. J. de Bruin.
 9387173x9—1/12/86, R50 000. H. Erasmus.
 9476839x7—1/2/87, R24 571. M. Erasmus; H. L. Erasmus.
 7195541x3—1/12/82, R3 515. J. Geiseb.
 3320497x5—1/9/76, R2 200. E. M. Coetzee.
 469238—1/11/51, R570. S. P. F. Wessels.
 619665—1/11/55, R2 000. H. P. en I. Uys.
 1816447x5—1/4/74, R5 000. R. W. van Niekerk; I. C. van Niekerk.
 3326208x0—1/9/76, R2 000. P. W. Viljoen.
 3331793x4—1/12/76, R1 280. R. van Olst.
 3331792x6—1/12/76, R2 345. R. van Olst.
 3414835x3—1/12/77, R1 002. W. Seele.
 3440180x2—1/5/76, R4 597. N. A. Basson.
 3845675x2—1/1/81, R6 640. J. H. Hietbrink.
 3998751x6—1/10/81, R5 136. L. P. Duvenhage.
 7038099x3—1/12/81, R5 625. L. H. Oosthuizen.
 7137113x2—1/5/82, R6 785. A. J. le Roux.
 7272118x6—1/9/82, R5 076. P. J. Britz.
 7923005x8—1/7/85, R11 083. M. P. Mabitsela.
 9084127x1—1/2/86, R5 630. E. Kleinhans.
 9616250x8—1/7/87, R7 829. D. Coetzee.
 3463304x0—1/6/78, R2 000. D. Barnard.
 1941528x0—1/4/75, R2 000. D. Barnard.
 1281475x2—1/9/67, R1 000. A. Engelbrecht.
 7732241x0—1/9/84, R7 300. F. E. Todt.

The Southern Life Association Limited, Great Westerford, Rondebosch, 7700

413667—4/4/49, R78. A. B. Peddie.
 672834—17/8/67, R6 000. T. J. L. van den Boogaard.
 694529—19/12/69, R20 000. L. Bouwer.
 714168—20/10/70, R2 000. W. P. Troskie.
 754818-3—13/11/73, R3 990. C. Adendorff.
 756018-7—26/3/74, R3 804. H. J. Visagie.
 758627-1—9/5/74, R2 000. A. Jordaan.
 780369-5—17/6/75, R1 036. R. J. Broome.
 854609-0—17/11/80, R12 890. S. T. Newbould.
 855314-8—24/9/80, R3 663. Wyle/Late J. L. Visser; D. W. E. Visser.
 862065-7—10/2/81, R15 545. R. M. da Silva.
 893361-6—13/4/82, R12 487. G. F. S. Marx.
 922820-7—17/6/76, R3 000. J. B. Hannah.
 1024420-9—17/4/84, R11 046. M. J. E. van Zyl.
 1026961-1—3/4/84, R65 000. R. D. Mac Farlane.
 1040729-5—11/9/84, R20 000. G. S. B. Kapp.
 1407003-9—21/5/85, S. B. Rack.
 1797580-1—6/10/86, R12 000. A. J. Bester.

The Southern Life Association Limited, Southern Life Centre, 45 Commissioner Street, Johannesburg, 2001

6090338—1/9/77, R1 302. G. T. N. Sotobe.
 6097441—1/8/77, R5 000. M. M. de Beer.

6100112—1/6/77, R4 000. L. J. P. Martin.
 6106920—1/1/74. G. Baise.
 6114424—1/2/78, R4 542. D. M. Moloto.
 6117200—1/6/78, R3 398. E. W. Johnstone.
 6125024—1/2/78, R6 077. D. G. Kganyago.
 6159926—1/5/80, R3 211. A. K. Matende.
 6174325—1/2/80, R10 000. A. V. Beukes.
 6178596—1/11/80, R11 908. J. C. Pullen.
 6180869—1/10/80, R9 497. H. P. Kodi.
 6198213—1/10/80, R21 153. M. A. Vachiat.
 6198749—1/2/81, R31 400. S. A. S. Dawood.
 6198750—1/12/80, R24 679. S. Dawood.
 6198916—1/2/81, R31 400. S. A. S. Dawood.
 6207241—1/4/78, R4 000. M. C. S. Steyn.
 6208677—1/9/81, R11 209. E. Francis.
 6213848—1/11/81, R34 500. S. S. Lala.
 5676711—1/8/84, R28 571. P. Scheepers.
 5687224—1/11/84, R35 000. D. T. Camacho.
 5693904—1/8/85, R20 000. M. M. Greef.
 5695356—1/4/85, R80 000. H. Appolis.
 1804403—1/10/85, R26 996. R. G. Albrecht.
 1821226-2—1/12/85, R80 000. E. H. Hayat.
 1823685-3—1/5/86, R100 000. M. C. de Beer.
 1834757-7—1/10/86, R70 274. L. R. Phiri.
 5400719—1/10/82, R10 000. G. R. Bone.
 5401555—1/8/83, E. R. Sekhonyana.
 5401604—1/6/82, A. M. Maseribane.
 5404033—1/5/82, R23 657. R. M. J. Arthur.
 5415247—1/1/83. P. Naidoo.
 5422079—1/8/83, R17 072. R. Johnston.
 5424127—1/10/83. S. J. Kuncil.
 5427470—1/12/84, R47 984. V. Randall.
 5427471—1/12/84, R47 984. V. Randall.
 5436907—1/4/84, R50 000. R. B. Masson.
 5437857—1/7/84, R94 049. A. D. Wilson.
 5606438—1/7/82, R5 000. B. N. Sokudela.
 5607835—1/10/82, R36 490. G. M. Mothusi.
 5616599—1/10/82, L. D. Brooker.
 5619483—1/3/83, R100 000. A. C. R. Fullaro.
 5622659—1/2/83, R53 000. S. W. Mapoha.
 5636084—1/2/83, R34 505. T. T. Brogan.
 5642273—1/7/83, R33 840. A. T. Molokele.
 5643730—1/10/83. M. E. Mabanga.
 5649289—1/7/83. M. P. Naicker.
 5681062—1/10/84, R33 921. J. J. Katzao.
 5660442—1/8/84, R40 355. J. J. Katzao.
 G69323—1/12/73, R20 000. E. W. Willmore.
 G69322—1/12/73, R10 000. E. W. Willmore.
 G452756—1/4/81, R50 000. J. H. Thompson.
 G441560—1/11/79, R3 000. J. H. Thompson.
 G459585—1/3/82, R100 000. H. D. Germishuysen.
 G707077—1/9/75, R5 718. G. C. van der Westhuizen.
 355363—1/5/52, R414. H. L. van der Merwe.
 588855—1/3/64, R10 000. I. H. Thompson.
 646195—1/4/67, R306. T. M. Madwanya.
 666132—1/3/68, R1 500. R. J. Westraadt.
 3005278—1/2/68, R600. R. Foster.
 4112333—1/6/69, R3 000. J. Barnard.
 4151026—1/6/69, R4 196. H. S. Coetzee.
 5001153—1/2/72, R4 000. B. L. Hayden.
 5031667—1/12/73, R3 556. J. F. la Cock.
 1792726—1/5/87, R71 352. N. du Rand.
 506175—1/11/60, R2 000. T. H. van Blerk.
 588463—T. H. van Blerk.
 892144—1/3/75, R5 000. E. M. Ebrahim.
 6006665—1/9/75, R3 345. J. A. Geldenhuys.
 6074333—1/9/77, R10 000. J. J. Wessels.
 5698107—Boedel wyle/Estate late J. H. Engelbrecht.
 835801—Boedel wyle/Estate late R. N. Gwelana.
 6041732—Boedel wyle/Estate late R. J. Malakalaka.
 6129247—Boedel wyle/Estate late C. M. Scina.

Vorm/Form MVA**DERDEPARTY-ASSURANSIE-EISE OM SKADEVERGOEDING****Wet op Verpligte Motorvoertuigversekering, 1972 (Wet 56 van 1972)****THIRD PARTY INSURANCE CLAIMS FOR COMPENSATION****Compulsory Motor Vehicle Insurance Act, 1972 (Act 56 of 1972)****KENNISGEWING DEUR BEVOEGDE VERSEKERAAR VAN OOREENKOMS BEDOEL IN ARTIKEL 26 VAN DIE WET**

Die bevoegde versekeraar genoem in die Bylae hiervan, gee hierby ooreenkomstig artikel 26 (4) van die Wet kennis—

(a) dat hy 'n ooreenkoms soos in artikel 26 (3) (c) bedoel, aangegaan het om 'n bedrag te betaal ten opsigte van 'n eis om skadevergoeding ooreenkomstig artikel 21 van genoemde Wet, naamlik vergoeding wat, indien genoemde versekeraar vir die betaling daarvan aanspreeklik sou gewees het, koste ten opsigte van die akkommodasie, in 'n hospitaal of verpleeginrigting, van die persoon in die Bylae hiervan genoem of ten opsigte van enige behandeling van of diens gelewer of goedere verskaf aan daardie persoon, kon insluit; en

(b) dat genoemde versekeraar nie ooreenkomstig artikel 26 (4) van die Wet verplig is nie om enige bedrag ten opsigte van sodanige koste te betaal aan engeen wat die akkommodasie of behandeling verskaf of die diens gelewer of die goedere verskaf het en wat nie 'n skriftelike eis voor die verstryking van 'n tydperk van 60 dae na die datum van hierdie kennisgewing by bogenoemde versekeraar ingedien het nie.

Die besonderhede word verstrek in die volgorde, onder die naam en adres van die geregistreerde maatskappy: Naam van persoon/persone beseer of gedood; eisnommer; datum en plek van ongeluk; naam van hospitaal, verpleeginrigting of plek waar behandel (indien bekend).

NOTICE BY AUTHORISED INSURER OF AGREEMENT CONTEMPLATED IN SECTION 26 OF THE ACT

The authorised insurer named in the Schedule hereto, hereby gives notice in terms of section 26 (4) of the Act—

(a) that he has entered into an agreement contemplated in section 26 (3) (c) to make a payment in respect of a claim for compensation under section 21 of the said Act, which compensation could, if the said insurer were liable for payment thereof, have included costs in respect of the accommodation of the person named in the Schedule hereto in a hospital or a nursing home or of any treatment of or service rendered or goods supplied to that person; and

(b) that, in terms of section 26 (4) of the Act, the said insurer shall not be obliged to pay any amount in respect of such costs to any person who provided the accommodation or treatment or rendered the service or supplied the goods who has not lodged a claim, in writing, with the said insurer prior to the expiration of a period of 60 days after the date of this notice.

The particulars are given in the following order, under the name and address of the registered company: Name of person(s) injured or killed; claim number; date and place of accident; name of hospital, nursing home or place where treated (if known).

Commercial Union Assurance Company of South Africa Ltd, P.O. Box 222, Johannesburg, 2000

Da Silva, Luiz Ferreira. Claim MVA 1312/34. 12 October 1983, National Fresh Produce Market, City Deep, Johannesburg. Johannesburg General Hospital.

Selkman, Keith Robert. Claim MVA 0921/45. 26 February 1985, Scott Street, Waverley. Johannesburg General Hospital and the Sandton Clinic.

Atkins, Bradford Lee. Claim MVA 1178/34. 13 June 1983, the intersection of Garden and Anderson Streets, Turffontein, Johannesburg. Johannesburg General Hospital.

President Versekeringsmaatskappy Bpk., Posbus 4095, Pretoria, 0001

Norton, Gavin Robert. Eis 4/L 8047. 19/4/84, Johannesburg. Suid-Rand Hospitaal.

Galanopoulos, A. Claim 5/F 8015. 7 January 1985, Fleet Street, East London.

Nel, Pamela M. Eis 6/M 8164. 1 Februarie 1986 te Durbanweg, Durbanville. Dr. J. Keet, The Crescent, Durbanville.

Burbridge, J. M. Eis 5/P 8079. 16 November 1984 te Auckland Park. Dr. Pitcher.

Denyer, Bruce C. Eis 86/M 7024. 4 Februarie 1986 te Windemereweg, Cambridge. Oos-Londen. Dr. Comfort & Vennote, Oos-Londen.

Help om ons land, Suid-Afrika, skoon te hou!

Please keep our country, South Africa, clean!

BELANGRIK!!

Plasing van tale:

Staatskoerante

1. Hiermee word bekendgemaak dat die omruil van tale in die *Staatskoerant* jaarliks geskied met die eerste uitgawe in Oktober.
2. Vir die tydperk 1 Oktober 1987 tot 30 September 1988 word Afrikaans EERSTE geplaas.
3. Hierdie reëling is in ooreenstemming met dié van die Parlement waarby koerante met Wette ens. die taalvolgorde deurgaans behou vir die duur van die sitting.
4. *Dit word dus van u, as adverteerder, verwag om u kopie met bogenoemde reëling te laat strook om onnodige omskakeling en stylredigering in ooreenstemming te bring.*

—oOo—

IMPORTANT!!

Placing of languages:

Government Gazettes

1. Notice is hereby given that the interchange of languages in the *Government Gazette* will be effected annually from the first issue in October.
2. For the period 1 October 1987 to 30 September 1988, Afrikaans is to be placed FIRST.
3. This arrangement is in conformity with Gazettes containing Acts of Parliament etc. where the language sequence remains constant throughout the sitting of Parliament.
4. *It is therefore expected of you, the advertiser, to see that your copy is in accordance with the above-mentioned arrangement in order to avoid unnecessary style changes and editing to correspond with the correct style.*

NOU BESKIKBAAR

VERSLAE VAN DIE APPÈLHOWE VIR KOMMISSARISHOWE

(In boekvorm)

1972–1974 (484 bladsye)

1975–1977 (338 bladsye)

Verkoopprys (AVB uitgesluit)

1972–1974: Plaaslik, R9,20; buitelands, R10,90; posvry

1975–1977: Plaaslik, R7,40; buitelands, R8,70; posvry

—oOo—

NOW AVAILABLE

REPORTS OF THE APPEAL COURTS FOR COMMISSIONERS' COURTS

(In book form)

1972–1974 (484 pages)

1975–1977 (338 pages)

Selling price (GST excluded)

1972–1974: Local, R9,20; other countries, R10,90; post free

1975–1977: Local, R7,40; other countries, R8,70; post free

Alle Proklamasies, Goewermentskennisgewings en Algemene Kennisgewings gepubliseer word vir verwysingsdoeleindes in die volgende inbondsopgawe ingesluit wat dus 'n weeklikse Indeks voorstel. Laat u self deur die Koerantnommers in die regterhandse kolom lei:

INHOUD

en weeklikse Indeks

No.		Bladsy No.	Staats-koerant No.
PROKLAMASIES			
R. 151	Swart Administrasiewet (38/1927): Natalse Wetboek van Zoeloereg	1	10966
153	Wet op die Vervoeradviesraad (58/1987): Inwerkingtreding	1	10987
GOEWERMEN- EN ALGEMENE KENNISGEWINGS			
Administrasie: Raad van Afgevaardigdes			
<i>Goewermentskennisgewing</i>			
R. 2265	Wet op Bevordering van Kultuur (35/1983): Regulasies	34	10966
Administrasie: Volksraad			
<i>Goewermentskennisgewings</i>			
2331	Wet op Huurbeheer (80/1976): Vrystelling van huurbeheer: Wonings, motorhuise, motorstaanplekke en bediendekamers: Port Elizabeth	1	10987
2332	do.: do.: do.: do.	3	10987
2333	do.: do.: do.: do.	7	10987
2334	do.: do.: do.: do.	9	10987
<i>Algemene Kennisgewing</i>			
759	Wet op Landboukrediet, 1966: Kennisgewing van vergadering: Coligny	130	10987
Binnelandse Sake, Departement van			
<i>Goewermentskennisgewings</i>			
2246	Wet op Publikasies (42/1974): Publikasies of voorwerpe	1	10961
2247	do.: do.: Verhoë ten opsigte van appél.	1	10961
2248	do.: do.: do.: do.	2	10961
2249	do.: do.: Verbod op besit van ongewenste publikasies of voorwerpe	2	10961
2250	do.: do.: Ongewenste publikasies of voorwerpe: Lys P87/42	2	10961
2251	do.: do.: Tersydstelling van verklaring dat publikasies ongewens is	3	10961
2252	do.: do.: Voorwaardes	3	10961
2253	do.: do.: do.: do.	3	10961
2254	do.: do.: do.: do.	4	10961
2255	do.: do.: do.: do.	4	10961
2256	do.: do.: do.: do.	4	10961
2279	Wet op Vreemdelinge (1/1937): Vansverandering: Moonsamy in Abraham	13	10987
2280	do.: do.: De Vos in Meyer	13	10987
2316	Wet op Vreemdelinge (1/1937): Vansverandering: Hoosen in Dhorat	13	10987
2317	do.: do.: Dorasamy in Govender	13	10987
Finansies, Departement van			
<i>Goewermentskennisgewings</i>			
R. 2262	Doeane- en Aksynswet (91/1964): Wysiging van Bylae I (No. 1/1/1333)	35	10966
2274	Wet op die Staatstenderraad (86/1968): Staatstenderraad: Heraanstelling van lid	13	10987
2283	Plaaslike/Binnelandse Geregistreeerde Efsfekte: Sluiting van oordragboeke: 1 November 1987 tot 1 Desember 1987	13	10987
2284	Staat van Inkomste: 1 April 1987 tot 31 Augustus 1987	14	10987
2310	Staat van Ontvangste in en Oordragte uit die Skatkisrekening vir die tydperk 1 April 1987 tot 30 September 1987	15	10987
Handel en Nywerheid, Departement van			
<i>Goewermentskennisgewings</i>			
2286	Wet op Standaarde (30/1982): Verpligte spesifikasie vir aardlekbeveiligingseenhede	17	10987
2287	do.: Verpligte spesifikasie vir stroombrekers met gevormde hulse	68	10987

For purposes of reference, all Proclamations, Government Notices and General Notices published are included in the following table of contents which thus forms a weekly index. Let yourself be guided by the Gazette numbers in the righthand column:

CONTENTS

and weekly Index

No.		Page No.	Gazette No.
PROCLAMATIONS			
R. 151	Black Administration Act (38/1927): Natal Code of Zulu Law	1	10966
153	Transport Advisory Council Act (58/1987): Coming into operation	1	10987
GOVERNMENT AND GENERAL NOTICES			
Administration: House of Assembly			
<i>Government Notices</i>			
2331	Rent Control Act (20/1976): Exemption from rent control: Dwellings, garages, parking spaces and servant's rooms: Port Elizabeth	1	10987
2332	do.: do.: do.: do.	3	10987
2333	do.: do.: do.: do.	7	10987
2334	do.: do.: do.: do.	9	10987
<i>General Notice</i>			
759	Agricultural Credit Act, 1966: Notice of meeting: Coligny	130	10987
Administration: House of Delegates			
<i>Government Notice</i>			
R. 2265	Culture Promotion Act (35/1983): Regulations	34	10966
Agricultural Economics and Marketing, Department of			
<i>Government Notices</i>			
R. 2258	Wine and Spirit Control Act (47/1970): Proposed maximum quantity of grapes which may be purchased or acquired during 1988/89	37	10966
R. 2259	do.: Price and payment arrangements with regard to good wine: 1987/88: Proposed amendment	37	10966
R. 2260	Marketing Act (59/1968): Deciduous Fruit Scheme: Notice by producers of deliveries of pears for export	38	10966
R. 2261	do.: do.: Notices of deliveries: Amendment	38	10966
2315	Co-operatives Act (91/1981): Co-operative remove from registered: Kuboes Koöperatiewe Handelsvereniging Beperk	119	10987
<i>General Notice</i>			
756	Quarterly report of brands registered from 1 July 1987 to 30 September 1987	128	10987
Development Planning, Department of			
<i>Government Notices</i>			
2278	Statement of provincial revenue collections: 1 April to 30 June 1987	121	10987
2328	Black Communities Development Act (4/1984): Designation and setting aside of land as a development area in the District of Boksburg	122	10987
2329	do.: do.: do.: do.	122	10987
2330	do.: do.: do.: do.	122	10987
Environment Affairs, Department of			
<i>Government Notices</i>			
2277	Forest Act (122/1984): Transvaal National Botanic Garden: Change of name	120	10987
2291	Forest Act (122/1984): Abrogation of the establishment of the Paarl-Franschhoek Fire Control Area and Fire Control Committee	120	10987
2292	do.: Abrogation of the establishment of the Rawsonville Fire Control Area and Fire Control Committee	120	10987

No.	Bladsy No.	Staatskoerant No.
Algemene Kennisgewings		
720		
721	1	10967
762	7	10967
	132	10987
Justisie, Departement van		
Goewermentskennisgewings		
R. 2257	36	10966
2318	119	10987
Algemene Kennisgewing		
758	1	10986
Landbou-ekonomie en -bemarking, Departement van		
Goewermentskennisgewings		
R. 2258	37	10966
R. 2259	37	10966
R. 2260	38	10966
R. 2261	38	10966
2315	119	10987
Algemene Kennisgewing		
756	128	10987
Mannekrag, Departement van		
Goewermentskennisgewings		
R. 2240	39	10966
R. 2268	39	10966
R. 2269	40	10966
R. 2270	41	10966
R. 2271	43	10966
R. 2272	1	10971
Algemene Kennisgewing		
761	131	10987
Mineraal- en Energiesake, Departement van		
Goewermentskennisgewings		
2275	119	10987
2276	119	10987

No.	Page No.	Gazette No.
Finance, Department of		
Government Notices		
R. 2262	35	10966
2274	13	10987
2283	13	10987
2284	14	10987
2310	15	10987
Home Affairs, Department of		
Government Notices		
2246	1	10961
2247	1	10961
2248	2	10961
2249	2	10961
2250	2	10961
2251	3	10961
2252	3	10961
2253	3	10961
2254	4	10961
2255	4	10961
2256	4	10961
2279	13	10987
2280	13	10987
2316	13	10987
2317	13	10987
Justice, Department of		
Government Notices		
R. 2257	36	10966
2318	119	10987
General Notice		
758	1	10986
Manpower, Department of		
Government Notices		
R. 2240	39	10966
R. 2268	39	10966
R. 2269	40	10966
R. 2270	41	10966
R. 2271	43	10966
R. 2272	1	10971
General Notice		
761	131	10987

No.	Bladsy No.	Staatskoerant No.	No.	Page No.	Gazette No.			
Algemene Kennisgewing			Mineral and Energy Affairs, Department of					
<i>Algemene Kennisgewing</i>			<i>Government Notices</i>					
757	Wet op Mynregte (20/1967): Uithou van grond vir die doeleindes van 'n openbare pad: Plaas Waterval 174 IQ, myndistrik Johannesburg.....	130	10987	2275	Mining Rights Act (20/1967): Reservation of land for the purpose of a public road: Farm Vlakfontein 161 IR, Mining District of Heidelberg.....	119	10987	
Nasionale Gesondheid en Bevolkingsontwikkeling, Departement van			<i>do.: Proposed deproclamation of land.....</i>			119	10987	
<i>Goewermentskennisgewing</i>			<i>General Notice</i>					
R. 2263	Wet op Geneeshere, Tandartse en Aanvullende Gesondheidsdiensberoep (56/1974): Die Suid-Afrikaanse Geneeskundige en Tandheelkundige Raad: Regulasies wat die omvang van die beroep ortopediese skoemaker omskryf	56	10966	757	Mining Rights Act (20/1967): Reservation for land for the purposes of a public road: Farm Waterval 174 IQ, Mining District of Johannesburg	130	10987	
Nasionale Opvoeding, Departement van			National Education, Department of					
<i>Goewermentskennisgewing</i>			<i>Government Notice</i>					
2273	Wet op Nasionale Gedenkwaardighede (28/1969): Bergingspermit.....	120	10987	2273	National Monuments Act (28/1969): Salvage permit.....	120	10987	
Omgewingsake, Departement van			National Health and Population Development, Department of					
<i>Goewermentskennisgewings</i>			<i>Government Notice</i>					
2277	Boswet (122/1984): Transvaal Nasionale Botaniese Tuin: Verandering van naam	120	10987	R. 2263	Medical, Dental and Supplementary Health Service Professions Act (56/1974): The South African Medical and Dental Council: Regulations defining the scope of the profession of orthopaedic bootmaker.....	56	10966	
2291	Boswet (122/1984): Intrekking van die instelling van die Paarl-Franschoek-brand-beheergebied en -brandbeheer Komitee	120	10987	Public Works and Land Affairs, Department of				
2292	Intrekking van die instelling van die Rawsonville-brandbeheergebied en -brandbeheer Komitee	120	10987	<i>General Notice</i>				
Ontwikkelingsbeplanning, Departement van			726			Land Titles Adjustment Act (68/1979): Acquisition of right on land as owner: Farm Rietvallei 406 JP, Transvaal.....	127	10987
<i>Goewermentskennisgewings</i>			Trade and Industry, Department of					
2278	Staat van invorderings van provinsiale inkomste: 1 April 1987 tot 30 Junie 1987.....	121	10987	<i>Government Notices</i>				
2328	Wet op die Ontwikkeling van Swart Gemeenskappe (4/1984): Aanwysing en afsondering van grond as 'n ontwikkelingsgebied in die distrik Boksburg	122	10987	2286	Standards Act (30/1982): Compulsory specification for earth leakage protection units	17	10987	
2329	do.: do.	122	10987	2287	do.: Compulsory specification for moulded-case circuit-breakers	68	10987	
2330	do.: do.	122	10987	<i>General Notices</i>				
Openbare Werke en Grondsake, Departement van			720			Companies Act (61/1973): Incorporation of companies: New companies and conversions from close corporations into companies	1	10967
<i>Algemene Kennisgewing</i>			721			Close Corporations Act (69/1984): Incorporation of close corporations: New close corporations and conversions from companies into close corporations	7	10967
726	Wet op Reëling van Grondtitels (68/1979): Reg op aanspraak op grond as eienaar: Plaas Rietvallei 406 JP, Transvaal.....	127	10987	762	Customs and Excise tariff applications: List 33/87.....	132	10987	
Waterwese, Departement van			Water Affairs, Department of					
<i>Goewermentskennisgewings</i>			<i>Government Notices</i>					
2335	Waterwet (54/1956): Breërivier-staatswater-beheergebied, afdelings Worcester, Robertson, Swellendam en Montagu, Kaapprovinsie: Uitbreiding van grense.....	123	10987	2335	Water Act (54/1956): Breede River Government Water Control Area, Divisions of Worcester, Robertson, Swellendam and Montagu, Cape Province: Extension of boundaries	123	10987	
2336	do.: Breërivier-staatswaterbeheergebied: Bepaling ingevolge artikel 63 (2b) van die Waterwet, 1956, van die maksimum omvang van grond wat bykomend by dié bepaal ingevolge artikel 63 (2) van genoemde Wet, besproei kan word	124	10987	2336	do.: Breede River Government Water Control Area: Determination in terms of section 63 (2B) of the Water Act, 1956, of the maximum extent of land that may be irrigated in addition to that determined in terms of section 63 (2) of the said Act	124	10987	
2337	do.: do.: Wysiging van die bepaling van die maksimum omvang van grond wat besproei kan word	127	10987	2337	do.: do.: Amendment of the determination of the maximum extent of land that may be irrigated	127	10987	
<i>Algemene Kennisgewings</i>			<i>General Notices</i>					
760	Waterwet (54/1956): Benede-Sondagsrivier-staatswaterbeheergebied, distrikte Jansenville, Kirkwood, Port Elizabeth en Somerset-Oos: Inlystingsvergadering.....	130	10987	760	Water Act (54/1956): Lower Sundays River Government Water Control Area, Districts of Jansenville, Kirkwood, Port Elizabeth and Somerset East: Scheduling Board meeting ...	130	10987	
763	Waterwet (54/1956): Krokodilrivier(Wes-Transvaal)-staatswaterbeheergebied: Inlystingsraadvergadering	134	10987	763	Water Act (54/1956): Crocodile River (Western Transvaal) Government Water Control Area: Scheduling Board meeting.....	134	10987	

No.	Bladsy No.	Staatskoerant No.	No.	Page No.	Gazette No.
RAADSKENNISGEWING			BOARD NOTICE		
63			63		
Wet op Verpleging (50/1978): Suid-Afrikaanse Raad op Verpleging: Aanwysiging van 'n lid van die Raad			Nursing Act (50/1978): South African Nursing Council: Designation of a member of the Council		
	134	10987		134	10987
Amptelike publikasies ontvang gedurende Julie 1987			Official publications received during July 1987		
	138			138	
<i>Belangrike aankondiging:</i> Gewysigde sluitingstye vir wetlike en Goewermentskennisgewings			<i>Important announcement:</i> Amended closing times for legal and Government notices		
	139			139	
WETLIKE ADVERTENSIES			LEGAL ADVERTISEMENTS		
Algemene Voorwaardes en Tariewe			General Conditions and Rates		
	136			136	
Algemeen			Administration of Estates Acts Notices		
	227			231	
Besigheidskennisgewings			Business Notices		
	140			140	
Boedelwettekennisgewings			Butchers' Notices		
	231			226	
Derdeparty-assuransie-eise			Change of Name		
	290			224	
Geregtelike en Openbare Verkope			Company Notices		
	158			143	
Handelsmerke in SWA			General		
	229			227	
Insolvensiewet- en Maatskappywette-kennisgewings			Insolvency Acts and Companies Acts Notices		
	259			259	
Likwidateurskennisgewings			Liquidators' Notices		
	147			147	
Maatskappykennisgewings			Lost Life Insurance Policies		
	143			281	
Naamsverandering			Orders of the Court		
	224			148	
Orders van die Hof			Public Auctions		
	148			158	
Publieke Veilings			Sales in Execution and Public Sales		
	217			157	
Slagterskennisgewings			Supersessions and Discharge of Petitions		
	226			290	
Tersydestellings en Afwysings van Aansoeke			Third Party Insurance Claims		
	157			229	
Verlore Lewensversekeringspolis			Trade Marks in SWA		
	281				